



Manual on Uniform Traffic Control Devices Supplement For The City of Colorado Springs

Revised 02/3/2023

TABLE OF CONTENTS

Executive Summary	3
Introduction	4
Goals	5
Objectives	6 - 7
General Requirements	8 - 10
Specific Requirements	11 - 14
Appendix A: Fee Schedule & Penalty Assessment	15
Appendix B: Traffic Technician Area Map	16
Appendix C: General Guide to Work Zone Traffic Control	17
Appendix D: Letter Codes & Formulas	18
Appendix E: Typical Applications	19 - 20
Appendix F: City Department & External Agency Information	21 - 22

TRAFFIC CONTROLS FOR STREET CONSTRUCTION, UTILITY WORK AND MAINTENANCE OPERATIONS

CITY OF COLORADO SPRINGS

EXECUTIVE SUMMARY

This field guide is a supplement to the Manual on Uniform Traffic Control Devices (M.U.T.C.D.) and is provided as a guide for any contractor, utility, or agency working in the public right-of-way. This document identifies the needs for traffic controls at work sites, establishes responsibility for traffic controls, defines the permit process, and gives typical urban traffic control applications. This manual also provides contact information for necessary agencies and establishes the need for public notification. The primary goal of this supplement is to increase awareness of the need for proper traffic control in work zones, ensuring efficient and safe completion of construction and maintenance operations.

TRAFFIC CONTROLS FOR STREET CONSTRUCTION, UTILITY WORK AND MAINTENANCE OPERATIONS

CITY OF COLORADO SPRINGS

INTRODUCTION

Construction and maintenance areas have significantly higher than average accident rates. As a result, special care should be taken in applying traffic control techniques in these areas. Traffic safety in construction zones should be an integral part of every project from planning, through design and construction. The City of Colorado Springs is very concerned with traffic control in work zones and has prepared this manual to aid construction and maintenance personnel in implementing safe and efficient methods for handling traffic.

The Manual of Uniform Traffic Control Devices (M.U.T.C.D.) and the Traffic Control Devices Handbook, distributed by the Institute of Transportation Engineers, are the recognized standard for all traffic control devices. This supplement is not meant to replace these publications, but to address the standard practices in the City of Colorado Springs. In all cases, the traffic control plan should conform to, or be of higher standards than, the methods outlined in the above mentioned publications.

Section 10.1.309 of the city traffic code establishes the authority of the Traffic Engineer to determine the installation of traffic control devices and provide for street closures. Additionally, the City Council of Colorado Springs established a resolution authorizing the Traffic Engineer to impose traffic control fees. This supplement is created under that authority, and describes the objectives, goals and requirements of the City of Colorado Springs for traffic control at work sites.

TRAFFIC CONTROLS FOR STREET CONSTRUCTION, UTILITY WORK AND MAINTENANCE OPERATIONS

CITY OF COLORADO SPRINGS

GOALS

Safety is the primary goal of any traffic control plan. Traffic control devices at work sites are necessary to protect motorists, bicyclists and pedestrians from encountering unexpected requirements or difficult maneuvers that could result in an accident. Traffic controls should route traffic through the work area in a manner that is as similar as possible to normal roadway conditions. Any unusual, unrecognized, or unclear traffic control device can have negative results such as drivers choosing an incorrect route or blocking the flow of traffic. Though work site hazards cannot be completely eliminated, they can be reduced through the following methods:

- Schedule work during off-peak traffic volume hours
- Coordinate work with other agencies to provide fewer traffic interruptions
- Investigate alternate locations for utility installations

Consistency in device appearance and use throughout the city will lead to better understanding by the driver and result in fewer accidents. All traffic control devices must meet or exceed the standards in the latest edition of the MUTCD. Traffic control devices must be laid out according to the approved Traffic Control Plan and associated Work Zone Traffic Control Permit.

Maintenance of traffic control devices is very important to their effectiveness. All traffic control devices must be maintained throughout the construction period to provide correct placement and legible faces both day and night. Maintenance includes cleaning or replacing dirty, missing or damaged devices. Routine day and night inspections are necessary; however, no standard schedule can be used for all conditions. Frequency should be based on common sense, with heavy traffic arterials requiring more frequent inspections. If inclement weather, vandalism, or other difficulties occur, more frequent inspections will be required. Follow-up action is required to make sure that any deficiencies have been corrected. The permit holder is responsible for the inspections and the corrective action.

TRAFFIC CONTROLS FOR STREET CONSTRUCTION, UTILITY WORK AND MAINTENANCE OPERATIONS

CITY OF COLORADO SPRINGS

OBJECTIVES

With the passage of resolution 39-02 the Colorado Springs City Council has authorized the City Traffic Engineer to impose traffic control fees. That resolution as well as city ordinance 01-42, states: “all work site traffic controls shall be approved by the city traffic engineer prior to commencement of work”, provided the need to implement an approval and inspection process. This is an outline of the objectives of the Traffic Control Program.

I. TRAFFIC CONTROL PERMIT APPROVAL

- A. Any contractor working in the City right-of-way, whether on the sidewalk or in the street, must obtain a Traffic Control permit. Permits will need to be applied for using the online permit system, and contractors must register for an account prior to applying for and purchasing permits. Registration information, application instructions, fee schedules and reference materials can all be found here: <https://coloradosprings.gov/public-works/page/right-way-permits-and-inspections?mlid=23901>.
- B. All permits must have a method of handling traffic or a Traffic Control plan attached to them. Traffic Engineering will accept custom plans if they are done neatly and with recognized drawing methods. Refer to the latest edition of the Manual on Uniform Traffic Control Devices (MUTCD) and the Traffic Control Devices Handbook for assistance in making custom drawings. Traffic Control plans for larger and more complex construction projects should be engineered drawings. For standard traffic control situations, a contractor may use the figures listed later in this section. This Traffic Controls Supplement is available as part of the Traffic Engineering Section of the Subdivision Policy, Public Works Design Manual or as a stand alone document. The stand alone document is available for purchase at the Permit and Inspections office, located in Suite 200-1 of the Regional Development Center. You can also view and/or print the document online at https://coloradosprings.gov/sites/default/files/inline-images/traffic_control_manual.pdf.
- C. Online permits are reviewed/approved on a daily basis. Permits should be applied for at least five days prior to commencement of work to ensure enough time for review and advance notice. Work Zone Traffic Technicians are available Monday - Friday during normal business hours to assist with traffic control issues. To contact Technicians directly, call the Permit and Inspections office at (719) 385-5977.

II INSPECTION

- A. All temporary traffic control is subject to inspection by Traffic Engineering staff. Inspectors monitor city streets on a daily basis. Inspections are usually random except for larger or more complex jobs which are inspected daily or as needed. Appendix B includes a map designating which inspector to contact for a certain area of the city.
- B. Due to the increasing volume of night and weekend work, inspection after normal business hours will be at the discretion of Traffic Engineering staff. Under certain circumstances, random inspections will be done during non-business hours.

III FEES AND PENALTIES

- A. Permit fees vary depending on traffic volumes where work is being done, and whether the contract work is telecommunication or non-telecommunication (see Appendix A).
- B. Fines are also outlined on this same schedule. Fines can be assessed for reasons ranging from no permit on site to safety issues; refer to general requirements on your printed permit for additional reasons for fines.
- C. All permit fees and fines must be paid using the online permit system or if necessary, payments can be accepted in person at the Permit and Inspections office located in Suite 200-1 of the Pikes Peak Regional Development Center. It is the responsibility of the contractor or project supervisor to have an approved Traffic Control Permit on site with a copy of the traffic control diagram.

TRAFFIC CONTROL FOR STREET CONSTRUCTION, UTILITY WORK AND MAINTENANCE OPERATIONS

CITY OF COLORADO SPRINGS

GENERAL REQUIREMENTS

1. Contractors are required to submit the Traffic Control application at least five working days prior to commencement of work to ensure enough time for review and advance notice. Activity requiring unique traffic control setups may require additional time for review and permit issuance, Traffic Engineering is not responsible for delays to a project due to this extended review time.
2. Traffic control permits are required for all operations that have a direct or indirect impact on public traffic (including motor vehicles (parked or moving), cyclists, and pedestrians) within the City Right-of-Way. Bicyclists and pedestrians should be provided with access and reasonably safe passage through the temporary traffic control work zone.
3. City policy does allow an exception for moving operations. Moving operations, defined as “activities in place less than thirty (30) minutes including time to setup and remove traffic control”, shall be exempt from the permit process. However, moving operations are not exempt from having a complete and appropriate setup per the latest edition of the MUTCD and the City of Colorado Springs supplement to the MUTCD. Improper setup does not exclude anyone from assessed fines for improper traffic control.
4. All traffic control devices shall meet or exceed MUTCD minimum requirements and comply with the MASH 350 criteria requirements.
5. Engineered drawings may be required for all minor arterial streets and above. Any waiver of this requirement will be at Traffic Engineering discretion.
6. Contractor generated traffic control plans will require a certified Traffic Control Supervisor to do work zone setups on all streets classified as Major Residential Collector and above.
7. Proof of Traffic Control Supervisor Certification by either the American Traffic Safety Service Association (ATSSA) or Colorado Contractors Association (CCA) with Flagger endorsement must be provided at time of submittal or be on record with the city.
8. Traffic control plan/permit shall be onsite at all times.
9. Permit fees are based on the number of traffic setups required to complete the project. Permit fees shall be paid in full prior to the permit being issued and prior to start of actual work.
10. Permits will be valid for the time period approved by City Traffic Engineering on the permit. Extensions may be granted if the contractor can justify the need.
11. Flagging personnel must be trained, certified and dressed appropriately.
12. Any changes to the Traffic Control Plan must have approval by City Traffic Engineering prior to implementation.

13. Any city signs removed or damaged must be replaced. Temporary signs shall be installed until permanent signs are replaced. All temporary and replacement signs shall meet the city's installation and materials standards. All signs conflicting with approved traffic control plan shall be covered or removed. All expenses incurred to remove, cover and/or replace signs will be the contractor's responsibility.
14. The repair or replacement of any damaged roadway pavement markings shall be the responsibility of the contractor per City Code 3.3.203. All stop lines, crosswalks, legends and arrows shall be 90 mil thickness and thermoplastic. All longitudinal lines shall be 15 mil thickness epoxy. Temporary pavement markings shall not be in place for more than two weeks unless approved by City Traffic Engineering. All pavement markings shall conform to the most recent adopted editions of the MUTCD and City of Colorado Springs Signs & Pavement Marking Guidelines.
15. An all weather surface must be in place before opening the roadway. Specific conditions may require the use of traffic plates. If used, they shall be properly anchored and maintained according to work zone time restrictions and construction schedule.
16. Traffic control must meet or exceed contractual specifications.
17. Contractors shall comply with the City Noise Ordinance # 3.3.2111.
18. City Traffic Engineering reserves the right to inspect all traffic control plans in operation and make changes as field conditions warrant.
19. Traffic Engineering shall be notified when an emergency occurs. All emergency work shall require that a permit application be filed and associated fees paid within 24 hours of the emergency or fines will be assessed accordingly.
20. Work involving state or county roadways within the Colorado Springs city limits must have permits from each of these agencies in addition to the required permit from the city. All permits must be on site at all times.
21. Vehicles and materials not related to the work in progress shall not be stored in the work area.
22. All temporary traffic control devices shall be removed once they are no longer needed. When work is suspended for short periods of time, temporary traffic control devices that are no longer appropriate shall be removed or covered.
23. When the construction zone involves metered parking, the contractor shall obtain parking meter bags or make other arrangements with Parking Administration for the allotted time.
24. A Uniformed Traffic Control Police Officer shall be required when traffic is shifted to run against a traffic signal unless the traffic signal can be modified to control the new roadway alignment.
25. Arrow boards are required for lane closures on all roadways with 4 or more lanes.
26. All traffic lanes shall be open to vehicular traffic between the hours of 06:00 A.M. to 09:00 A.M. and between the hours of 04:00 P.M. to 07:00 P.M. unless authorized by City Traffic Engineering.

27. If a Special Event and Work Zone Traffic Control Permit are scheduled at the same time, coordination shall be required between the contractor, event holder and City Traffic Engineering to resolve any potential conflicts that may occur.
28. All trenching will require adequate shoring or slope and any trench 5 feet or deeper requires notification of the Colorado Springs Fire Department.
29. Inclement Weather Conditions:

In the event of inclement weather work within City right-of-way (ROW) will not be permitted unless approved by the City Traffic Engineer or a representative of Traffic Engineering. Examples of inclement weather include but are not limited to the following:

 - Fog/low visibility
 - High winds—this applies to wind gusts where traffic control devices become hazards to pedestrians and the motoring public
 - Snow and ice events that include callouts of city plows, “wagon” tracks in traffic, snow packed streets that could cause unsafe conditions for the public and work crews, etc.

Weather conditions can differ throughout the city which may allow for contractors and their barricade companies to continue work with a safety-first approach when working in the elements; at any time the City Traffic Engineer or their representative deems that conditions are no longer safe work will cease until it is safe to continue.
30. Street Closures:

Projects on roadways classified as Minor Collectors and above will require a project schedule to be submitted with the requested Traffic Control Permit; the schedule should include the start and completion date of the project as well as the work to be performed.

At the discretion of the City Traffic Engineer or their representatives projects that exceed the approved project schedule may be subject to daily fines until the roadway is re-opened.
31. To determine if the segment of roadway is on a City Transit Route, go to <https://coloradosprings.gov/mountain-metro/page/bus-route-information?mlid=8426>, then click on the System Map button to view the route map.
32. To determine if the segment of roadway is on a City Snow Plow Route, go to <https://coloradosprings.gov/public-works-operations-maintenance-division/page/snow-plow-information?mlid=29911>, then scroll down and click on the Snow Plow Routes tab.
33. To determine if the segment of roadway is on a City Truck Route, go to <https://coloradosprings.gov/public-works/page/oversizeoverweight-load-permits>, then scroll down to the Truck Routes & Restrictions section to view route maps.

**TRAFFIC CONTROL FOR STREET CONSTRUCTION,
UTILITY WORK AND MAINTENANCE OPERATIONS**

CITY OF COLORADO SPRINGS

SPECIFIC REQUIREMENTS

Temporary Traffic Barrier:

The Contractor shall install Pre-cast Type 7F concrete, Type IV concrete, or Plastic Water Filled barrier between any lanes carrying public traffic and any excavation, obstacle, or storage area when the following conditions exist:

- When an excavation is 12 inches or greater in depth a minimum clear zone (CZ) in feet shall be required for the following design speeds:

30 MPH	35 MPH	40 MPH	45 MPH	50 MPH	55 MPH	60 MPH
12' CZ	14' CZ	16' CZ	20' CZ	22' CZ	24' CZ	30' CZ

- If the minimum Clear Zone cannot be maintained, then a temporary traffic barrier shall be required for work site protection.
- A temporary traffic barrier shall be supplemented with standard delineation (reflectors), pavement markings, or channelizing devices to provide nighttime visibility for vehicle traffic. The delineation or pavement marking color shall conform to the latest edition of the MUTCD.
- Temporary traffic barrier ends shall be installed in accordance with AASHTO's "Roadside Design Guide" by flaring until the end is outside the acceptable clear zone (clear zone is based on 85th percentile speed) or by providing crashworthy end treatments that meet or exceed MASH 350 Report.
- A temporary traffic barrier is required when the contractor has installed a permanent obstacle and the protective system, such as guardrail has not been installed or when a portion of an existing protective guardrail has been removed.
- A temporary traffic barrier is required when materials or equipment are stored within the clear zone of the work site.
- The use of a 12 ft. transition section is allowed at the downstream end of the installation pointing away from approaching traffic out of the clear zone, or at locations outside the clear zone, generally more than 30 ft. from the high speed travel lane edge.
- Glare Screens may be required, if used the blade height shall be 24".

Temporary Traffic Signals:

Temporary traffic signals must meet the physical display and operational requirements of conventional traffic signals. A minimum of two signal faces shall be provided for each approach, and each signal face shall consist of three 12 inch sections. The traffic signal controller must be capable of two-phase operations unless otherwise specified, and have all-red timing intervals.

Pedestrian Requirements:

- All pedestrian access must meet the American Disabilities Act (ADA) standards. All temporary walk surfaces shall be cold patched, asphalt or concrete and must not exceed 8.3% grade per ADA standards.
- When doing work involving a sidewalk or pedestrian walkway, the traffic control plan must contain appropriate protection for pedestrians (fencing, barriers, or covered walkways) and must be approved by Traffic Engineering.

Scaffolds & Overhead Work:

- The contractor shall provide protection to the pedestrian when doing overhead work. All heights 6 ft. and greater are considered overhead.
- An overhead, lighted canopy shall be constructed for pedestrians adjacent to any erected scaffolding. Pedestrian clearance shall be eight feet in height and five feet in width. ADA ramps, with an 8.3% grade or flatter shall be constructed if the pedestrian canopy walk is constructed in the roadway.
- All canopy construction within the city right-of-way shall comply with the requirements of the applicable local agency or the latest edition of the Uniform Building Code whichever contains the higher standard.
- To prevent objects from falling off, scaffolds shall provide guardrail systems, safety nets or personal fall arrest systems. Scaffolds shall have toe boards, screens, or guardrail systems to prevent objects from falling from a higher level.
- Materials shall not be stored on scaffolds. All material placed on scaffolds shall be removed at the end of the work shift.

Excavation and Trenches:

Excavations and/or trenches, which cannot be properly back-filled and patched prior to the end of the work day, shall be bridged to permit unobstructed traffic flow. Trench walls and adjacent soils shall be sufficiently stabilized prior to the use of steel plates for bridging.

Where traffic must cross trenches:

- The use of steel plates shall be approved by City Traffic Engineering prior to installation.
- The Colorado Springs Fire Department – Heavy Rescue Response Group shall be notified when the excavation or trench is 5 feet or greater in depth.
- Steel Trench Plate width and thickness requirements:

18" or less in width	Minimum thickness of $\frac{3}{4}$ "
> 18" in width to 72" in width	Minimum thickness of 1"

- The thickness of Steel Plates for trench widths exceeding 72" a structural design shall be prepared by a Licensed Professional Engineer Registered in Colorado.
- Steel Plates can be installed in two ways. First, the Steel Plates can be installed flush with the existing pavement, milling out the pavement surface to ensure that the top of plate elevation matches the existing elevations of adjacent pavement surface. Second, the Steel Plates can be installed on top of the asphalt with transitional ramps (cold mix) on all four sides of the plates, with feathered edges to match the existing asphalt (8% or a lesser slope).
- The Steel Plates shall extend beyond the edge of the trench a minimum of 18" but no more than 30" on both sides.
- A non-skid surface treatment shall be applied to the entire surface area of the plate in the direction of traffic flow.
- The contractor should avoid using a long series of plates that run parallel to traffic wheel paths. If allowed, the length of a series of plates running parallel to traffic wheel paths shall not exceed 30'.
- The trench shall be adequately shored to support the steel plates and traffic loads.
- Steel Plates shall be installed to operate with minimum noise.
- All Steel Plates within the right-of-way, whether used in or out of the traveled way, shall be without deformation (free from any clips, chains, attachments, weldments, or surface irregularities).
- No one is allowed in the trench while covered by the Steel Plate.
- The use of Steel Plates shall not exceed four weeks and Rough Road or Bump signs shall be required during this period of time.

Arrow Boards:

Arrow Boards shall be furnished as required by project conditions and shall meet the following requirements:

Type	Minimum Size	Min. # of Panel Lamps	Min. Legibility Distance
A	48" x 24"	12	½ mile
B	60" x 30"	13	¾ mile
C	96" x 48"	15	1 mile

(Example: length of arrow equals 48"; width of arrowhead equals 24")

An arrow panel is a sign with a matrix of elements capable of flashing or showing sequential displays. This sign shall provide additional warning and directional information to assist in merging and channeling road users through or around a temporary traffic control zone. The panel face shall be rectangle in shape, solid construction and finished in non-reflective black. The arrow panel shall have the capability of the following mode selection: left arrow, right arrow, left and right arrow and caution. The caution mode consists of four or more flashing lamps arranged in a pattern which does not indicate a direction. Arrow panels shall include an automatic photocell sensor type signal lamp dimmer with manual override and shall be capable of a minimum of 50 percent dimming from rated lamp voltage.

Portable Variable Message Signs:

Variable Message Signs (VMS) are temporary traffic control devices with the flexibility to display a variety of messages. Each message shall consist of one or two phases. A phase consists of up to three lines of eight characters per line. Each character module shall use at least five wide and seven high pixel matrixes.

- VMS's shall be used on all major residential collector streets and higher classification of roadways, including roadway closures and detour routes. Also, VMS's shall be used when lane reductions can not handle the normal volume of traffic (no greater than 1,000 vehicles per lane per hour).
- VMS's shall be used to advise vehicular traffic of alternate routes and expected delays due to construction activity.
- VMS's shall be used to notify the general public of upcoming construction activities up to two weeks prior to start of construction.
- VMS's shall be solar powered or a non-internal combustion device.
- VMS's shall be equipped with a power source and a battery back-up to provide continuous operation when failure of the primary power source occurs.
- VMS's shall be capable of 360 degree rotation and elevated so the bottom of the sign is 5 feet above the ground.
- The sign shall be visible from one-half mile during both daytime and nighttime conditions.
- The message shall be legible from a minimum of 650 feet.
- The sign shall automatically adjust its light source to meet nighttime legibility requirements.

APPENDIX A

FEE SCHEDULE & PENALTY ASSESSMENT

Traffic Control Permit Non-Telecommunication Provider/Non-Cable Operator	Rate (per permit, per setup)
> 5,000 Average Daily Traffic on affected street	\$198.00
< 5,000 Average Daily Traffic on affected street	\$55.00

Traffic Control Permit Telecommunication Provider/Non-Cable Operator	Rate (per permit, per setup)
> 5,000 Average Daily Traffic on affected street	\$180.40
< 5,000 Average Daily Traffic on affected street	\$49.50

Penalty for No Traffic Control Permit Non-Telecommunication Provider/Non-Cable Operator & Telecommunication Provider/Cable Operator (not including permit fee, penalty only)	Penalty	Penalty
	> 5,000 ADT	< 5,000 ADT
First Penalty for No Permit for Activity	\$ 396.00	\$110.00
Second Penalty for No Permit for Activity	\$ 594.00	\$165.00

Penalty for Non-Compliance of Traffic Control Permit Non-Telecommunication Provider/Non-Cable Operator & Telecommunication Provider/Cable Operator (not including permit fee, penalty only)	Penalty	Penalty
	> 5,000 ADT	< 5,000 ADT
First Penalty for Non-Compliance Permit	\$ 396.00	\$110.00
Second Penalty for Non-Compliance Permit	\$ 594.00	\$165.00

APPENDIX B

Traffic Barricade Areas

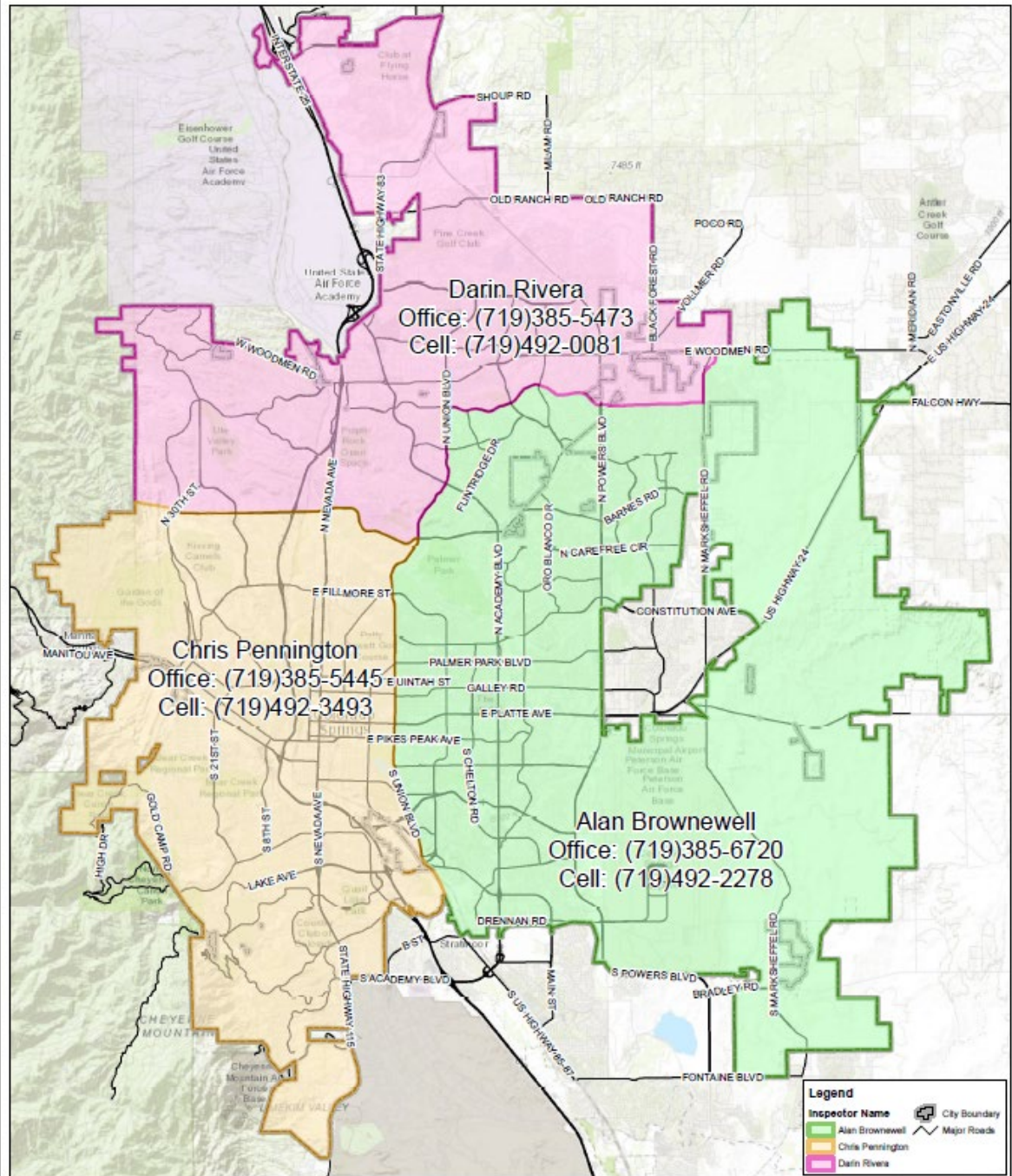

Department: Public Works/Asset Management Team
 Name: RLV_20220622_Traffic_Barricade_Areas_0X11
 Date Saved: 6/22/2022 11:32:31 AM

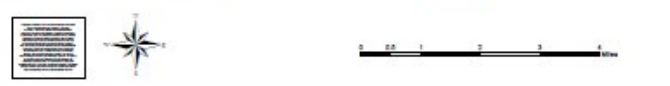
APPENDIX C

GENERAL GUIDE TO WORK ZONE TRAFFIC CONTROL

General Guide to Work Zone Traffic Control

	Interstate (2)	Expressway (2)	Principal Arterial (2)	Minor Arterial (2)	Commercial	Major Res. Collector	Minor Res. Collector	Residential Street	Minor Residential	Hillside Minor Res.
Number of Traffic Lanes	2, 4, 6	2, 4, 6	2, 4, 6	3, 4, 6	2, 3, 4	2, 3, 4	2, 3	2	2	2
ADT	80,000	76,000	15,000 to 50,000	10,000 to 25,000	7,500 to 10,000	3,500 to 10,000	1,500 to 3,500	750 to 1,500	100 to 750	200
Time Restrictions (No Work 6 AM to 9 AM & 4 PM to 7 PM)	yes	yes	yes	yes	yes	yes				
Noise Restriction (7 PM to 7 AM in All Residential Areas)			possibly	possibly	possibly	yes	yes	yes	yes	yes
Shoulder Closure Allowed	yes	yes	yes	yes	yes	yes	yes	yes	yes	yes
Sidewalk Closure Allowed			yes	yes	yes	yes	yes	yes	yes	yes
Single Lane Closure (9 AM to 3 PM) Allowed	yes-night	yes-night	yes	yes	yes	yes	yes	yes	yes	yes
Multi-Lane Closure (Weekends & Nights) Allowed	note #5	note #5	note #5	note #5	yes	yes	yes	yes	yes	yes
Street Closure Allowed	note #5	note #5	note #5	note #5	yes	yes	yes	yes	yes	yes
Night Work Allowed	yes	yes	yes	yes	yes	yes	yes	yes	yes	yes
Weekend Work Allowed	yes	yes	yes	yes	yes	yes	yes	yes	yes	yes
Flaggers Required				possibly	yes	yes	yes	yes	yes	yes
Detour Routes (reasonable distance w/o cut thru's) Required	yes	yes	yes	yes	yes	yes	yes	yes	yes	yes
Portable VMS's Required	yes	yes	yes	yes	yes	yes		yes	yes	yes
Arrow Boards Required	yes	yes	yes	yes	possibly	possibly				
Portable Traffic Signals Allowed				yes	yes	yes	yes	yes	yes	yes

Note:

* This table represents general requirements under average conditions.

1. All subject to change pending on site evaluation, roadway design, ADT, hourly vpl, speed, # of lanes, weather, time of year, school walk routes, Fire, Transit, and Truck routes.

2. All roadways which are under CDOT jurisdiction requires CDOT's approval and permit.

3. Flaggers required for One-Lane Roadways and Truck Access (entering & exiting)

4. Uniform Traffic Control (UTC) required where traffic is routed against a traffic signal.

5. Requires extensive coordination with City, County and CDOT and only allowed under extreme conditions.

6. All requirements subject to City Code.

APPENDIX D

LETTER CODES & FORMULAS

LETTER CODES

Road Type	Distance between Signs in Ft (metric)		
	A	B	C
Urban (low speed)	100 (30)	100 (30)	100 (30)
Urban (high speed)	350 (100)	350 (100)	350 (100)
Rural	500 (150)	500 (150)	500 (150)
Expressway / Freeway	1000 (300)	1500 (450)	2640 (800)

Type of Taper	Taper Length (L)*
Merging Taper	At least L
Shifting Taper	At least 0.5 L
Shoulder Taper	At least 0.33 L
One-Lane, Two-Way Traffic Taper	100 ft (30m) maximum
Downstream Taper	100 ft (30m) per lane

FORMULAS

Speed Limits of 40 mph (60 km/h) or less / Speed Limits of 45 mph (70 km/h) or >:

$$L = \frac{WS^2}{60}$$

$$(L = \frac{WS^2}{155})$$

$$L = WS$$

$$(L = \frac{WS}{1.6})$$

Lane Width	Speed in MPH	25 MPH	30 MPH	35 MPH	40 MPH	45 MPH	50 MPH	55 MPH	60 MPH	65 MPH
10 ft.	Merging Taper	105'	150'	205'	270'	450'	500'	550'	600'	650'
11 ft.	Merging Taper	115'	165'	225'	294'	495'	550'	605'	660'	715'
12 ft.	Merging Taper	125'	180'	245'	320'	540'	600'	660'	720'	780'

Where: L = Taper length in feet (meters)
 W = Width of offset in feet (meters)
 S = Posted speed limit, or off-peak 85th-percentile speed prior to work starting, or the anticipated operating speed in mph (km/h)

* Distances are shown in feet (meters)

APPENDIX E

TYPICAL APPLICATIONS

Typical Application Description	Typical Application No.
Sidewalk Detour	T.A. # 1
Sidewalk Diversion	T.A. # 2
Sidewalk Diversion within Parkway	T.A. # 3
Ramp Closure Pedestrian Detour	T.A. # 4
Work Beyond the Shoulder	T.A. # 5
Work on the Shoulder	T.A. # 6
Shoulder Work with Minor Encroachment	T.A. # 7
Lane Shift with Parking Restrictions	T.A. # 8
Lane Closure on Two-Lane Road with Flaggers	T.A. # 9
Work in Center of Road with Low Traffic Volume	T.A. # 10
Outside Single Lane Closure on Four Lane Road	T.A. # 11
Inside Single Lane Closure on Four Lane Road	T.A. # 12
Interior Lane Closure on Multi-Lane Road	T.A. # 13
Half Road Closure on Multi-Lane Road	T.A. # 14
Outside Lane Closure on Five Lane Road	T.A. # 15
Continuous & Inside Lane Closure on Five Lane Road	T.A. # 16
Work in the Continuous Lane on Five Lane Road	T.A. # 17
Multi-Lane Closure on Five Lane Road	T.A. # 18
Inside Lane Closure on Multi-Lane Road - Raised Median	T.A. # 19
Outside Lane Closure on Multi-Lane Road - Raised Median	T.A. # 20
Outside Lane Closure on Far Side of the Intersection with Sidewalk Closure	T.A. # 21
Outside Lane Closure on Far Side of the Intersection with No Sidewalk Closure	T.A. # 22
Inside Lane Closure on Far Side of the Intersection	T.A. # 23
Half Road Closure on Far Side of the Intersection	T.A. # 24
Multiple Lane Closure on Far Side of the Intersection	T.A. # 25
Closure in Center of the Intersection	T.A. # 26
Closure in Corner of the Intersection	T.A. # 27
Overlapping Routes with Detour	T.A. # 28
Alley Closure	T.A. # 29
Local Road Closure	T.A. # 30
Multi-Lane Closure on Six Lane Road	T.A. # 31
Outside Lane Closure on Far Side of the Intersection	T.A. # 32
Left Turn Bay Closure	T.A. # 33
Right Turn Bay Closure	T.A. # 34

APPENDIX E (Continued)

Typical Application Description	Typical Application No.
Center Lane Closure on Six Lane Road	T.A. # 35
Lane Closure Shifting Traffic into the Continuous	T.A. # 36
Lane Closure on Low Volume Road	T.A. # 37
Work Inside of a Roundabout	T.A. # 38
Work Outside of a Roundabout	T.A. # 39
Work Inside of a Multi-Lane Roundabout	T.A. # 40
Inside Lane Closure Multi-Lane Roundabout	T.A. # 41
Outside Lane Closure Multi-Lane Roundabout	T.A. # 42
One Lane Road with Temporary Traffic Signals	T.A. # 43
Outside Lane Closure with Sidewalk Closure	T.A. # 44
Half Road Closure on Multi-Lane Road	T.A. # 45
Shoulder Work with Bike Lane Closed	T.A. # 46
Outside Single Lane Closure with Bike Lane Closed	T.A. # 47

APPENDIX F

CITY DEPARTMENT & EXTERNAL AGENCY INFORMATION

Traffic Engineering Division
30 S. Nevada Ave., Ste. 405
Colorado Springs, CO 80901-1575
(719) 385-5918

Questions concerning work
zone traffic control

Traffic Engineering Signals
404 W. Fontanero St.
Colorado Springs, CO 80907
(719) 385-5918

Questions concerning traffic
signals and work at signalized
intersections

Traffic Management Center
234 W. Colorado Ave.
Colorado Springs, CO 80901
(719) 385-5918

Questions concerning signal
timing and video vehicle
detection

Traffic Engineering Signs/Markings
404 W. Fontanero St.
Colorado Springs, CO 80907
(719) 385-5918

Questions concerning signs
and markings on public streets

Permit & Inspections Office
2880 International Cir., Ste. 200-1
Colorado Springs, CO 80910
(719) 385-5977

Questions concerning
Excavation, Concrete and
Traffic Control permits

Colorado Springs Police Department
Gold Hill – 705 S. Nevada Ave.
Colorado Springs, CO 80903
(719) 444-7000

Notification of street closures
and work on major arterials

Colorado Springs Fire Department
375 Printers Parkway
Colorado Springs, CO 80910
(719) 444-7000

Notification of street closures
and trench excavation depths 5
feet or greater in depth

Colorado Springs Parking System
30 S. Nevada Ave., Ste. 504
Colorado Springs, CO 80901
(719) 385-5681

Questions regarding parking
meter hood(s) rental

APPENDIX F (Continued)

Colorado Department of Transportation

Pueblo Office:

P.O.Box 536
905 Erie St.
Pueblo, CO 81002
(719) 546-5743

Questions concerning permits and work zone traffic control on Federal and State highways

Springs Office:

1480 Quail Lake Lp., Ste. A
Colorado Springs, CO 80906
(719) 634-2323

Questions concerning permits and work zone traffic control on Federal and State highways

El Paso County Dept. of Public Works

3640 Marksheffel Rd.
Colorado Springs, CO 80922
Office (719) 520-6460
Fax (719) 520-6879

Questions concerning permits and work zone traffic control on County roadways

School District Phone Numbers

District 2: (719) 579-2000
District 11: (719) 520-2000
District 12: (719) 475-6100
District 20: (719) 598-2566
District 49: (719) 495-3601

Utility Locating

UNCC: 811 or (800) 922-1987

Springs Transit

Main Number: (719) 385-7460

INDICATE
NORTH

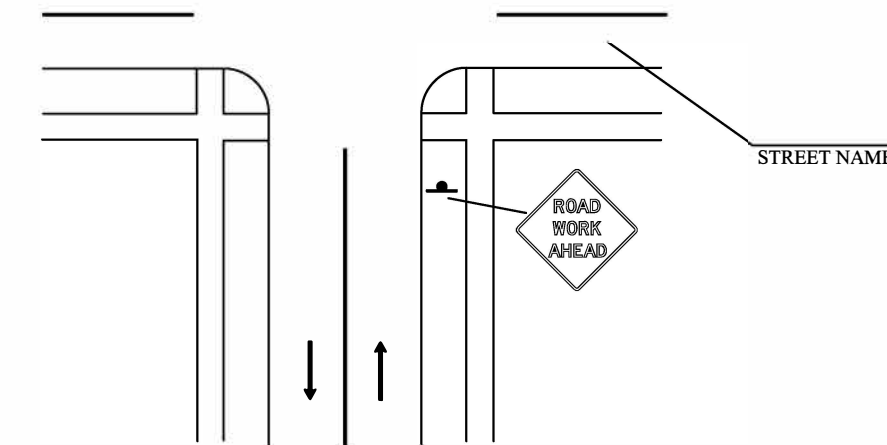
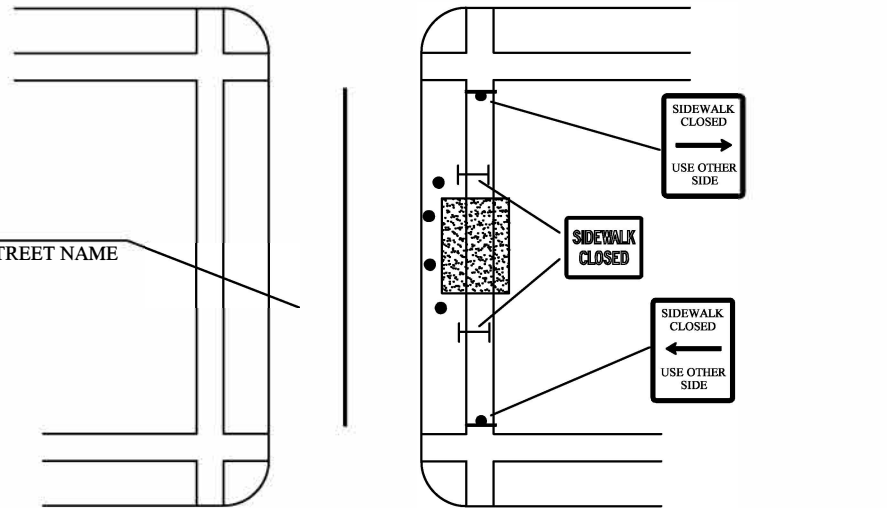
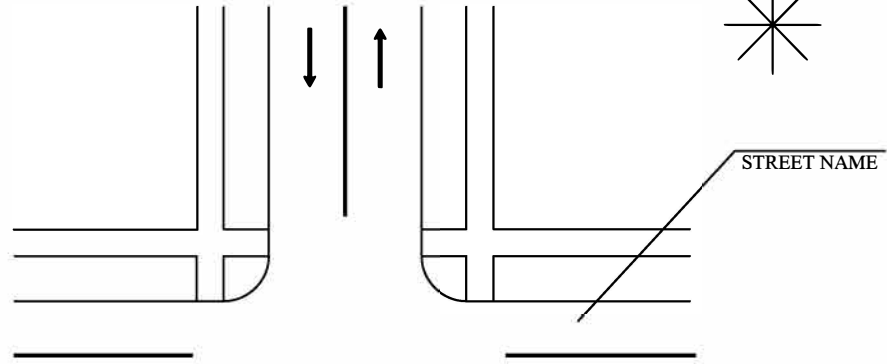
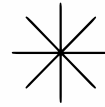

LEGEND

- CHANNELIZING DEVICE
- ⊥ TYPE I OR II BARRICADE
- SIGN STAND
- ▨ WORK AREA
- ↑ DIRECTION OF TRAVEL

* FOR SIGN SPACING AND TAPER LENGTH REFER TO APPENDIX "D".

INDICATE NORTH

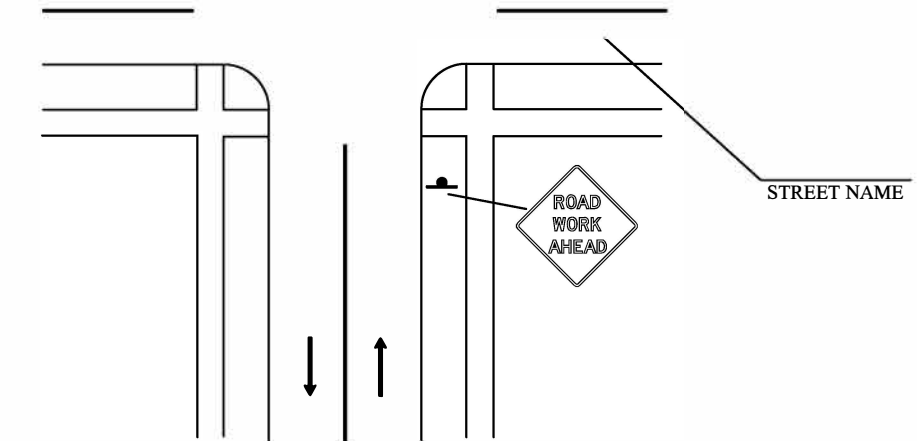
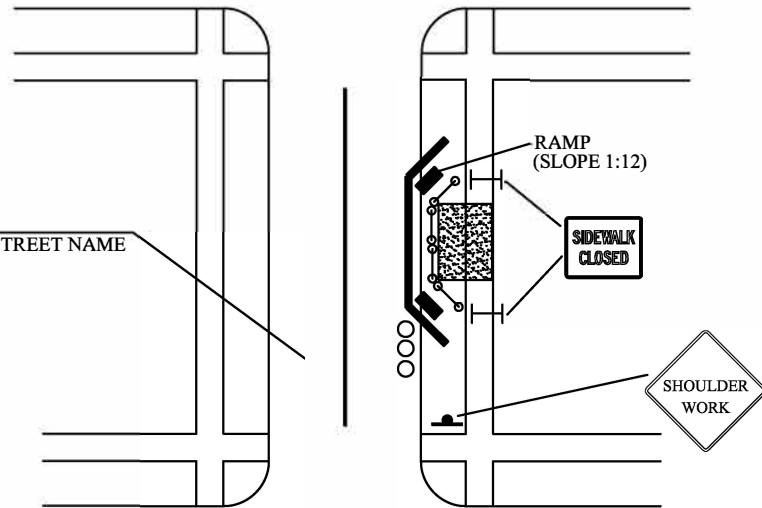
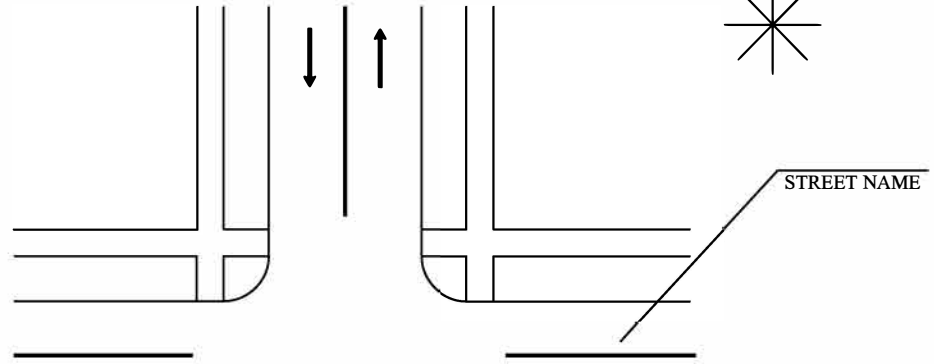
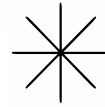

LEGEND

- IMPACT ATTENUATOR
- ⊥ TYPE I OR II BARRICADE
- SIGN STAND
- ▨ WORK AREA
- ↑ DIRECTION OF TRAVEL
- TRAFFIC BARRIER
- FENCING OR PED BARRIER

* FOR PROPER TRAFFIC BARRIER AND END TREATMENT USE REFER TO SPECIFIC REQUIRMENTS

* FOR SIGN SPACING AND TAPER LENGTH REFER TO APPENDIX "D".

INDICATE
NORTH

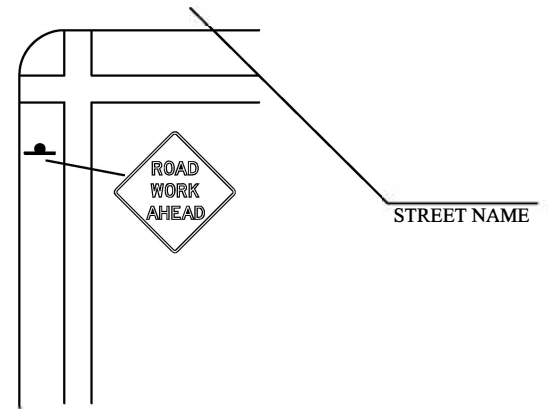
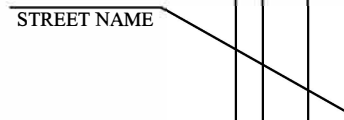
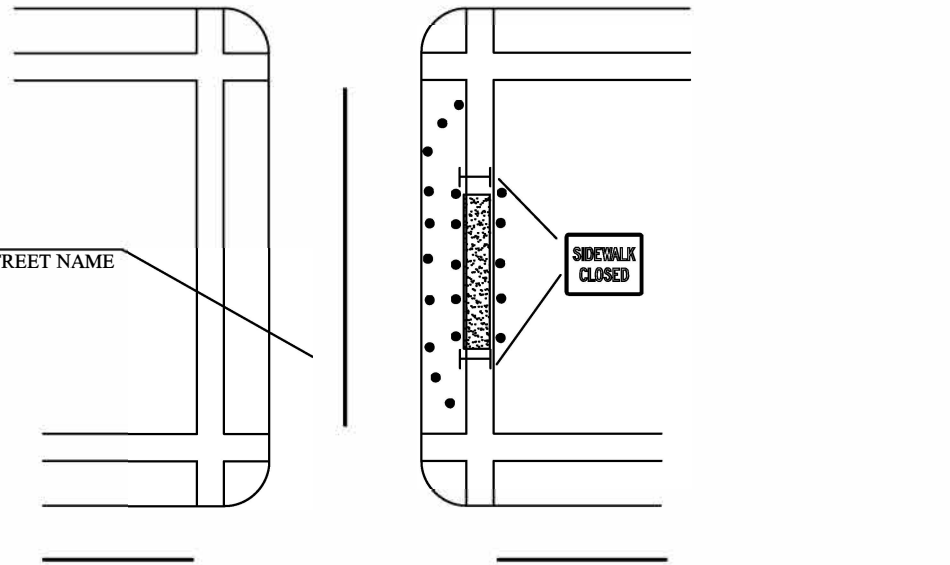
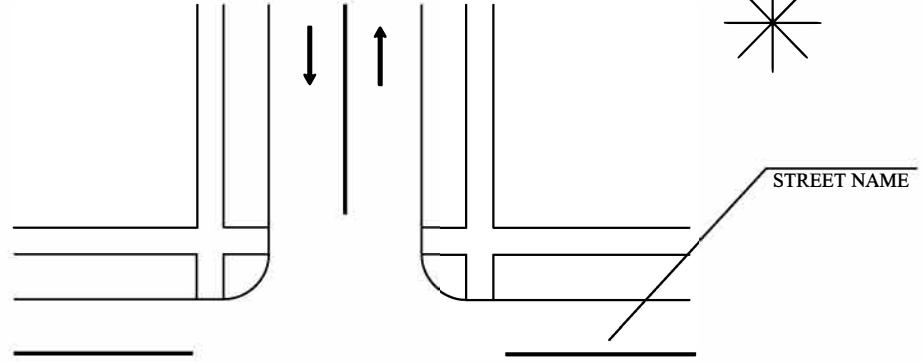
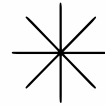

LEGEND

- CHANNELIZING DEVICE
- ⊥ TYPE I OR II BARRICADE
- SIGN STAND
- ▨ WORK AREA
- ↑ DIRECTION OF TRAVEL

* FOR SIGN SPACING AND TAPER LENGTH REFER TO APPENDIX "D".

INDICATE
NORTH

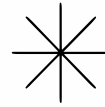

LEGEND

- CHANNELIZING DEVICE
- ⊥ TYPE I OR II BARRICADE
- SIGN STAND
- ▨ WORK AREA
- ↑ DIRECTION OF TRAVEL

* FOR SIGN SPACING AND TAPER LENGTH REFER TO APPENDIX "D".

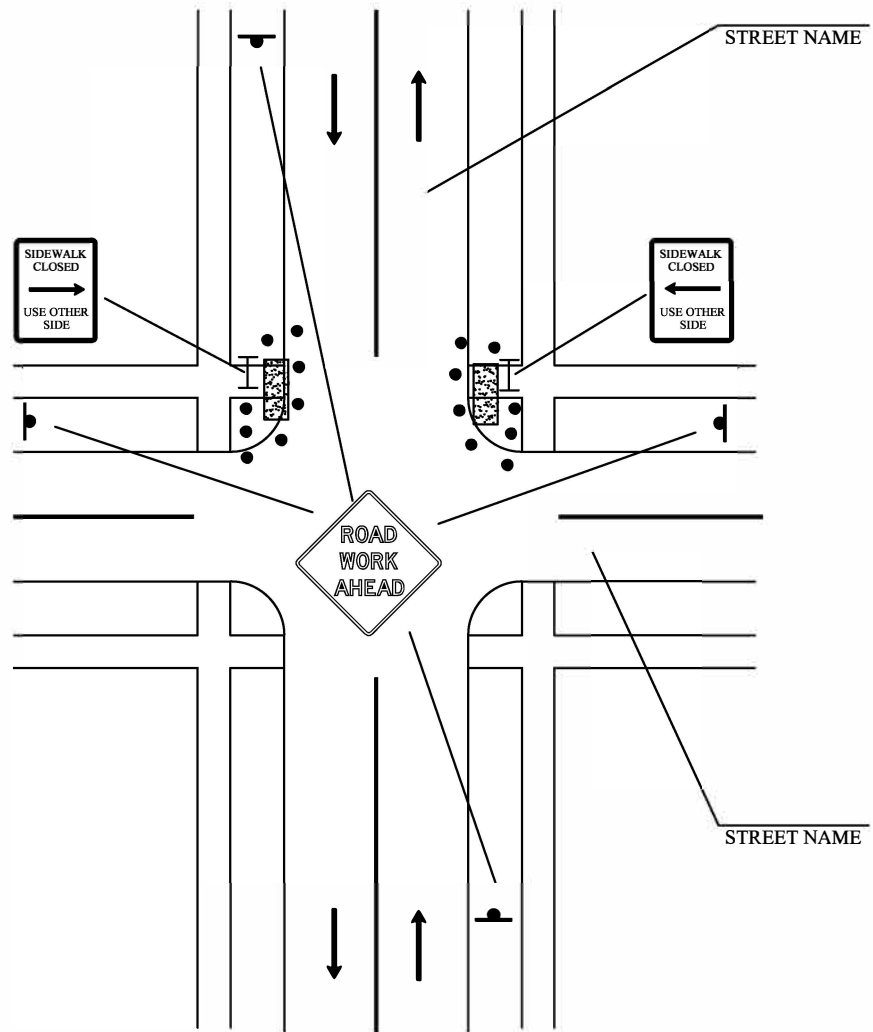

INDICATE
NORTH

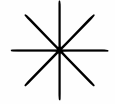

STREET NAME

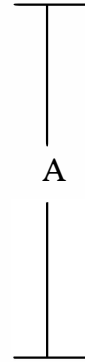

LEGEND

 SIGN STAND

 WORK AREA

 DIRECTION OF TRAVEL

* FOR SIGN SPACING AND TAPER LENGTH REFER TO APPENDIX "D".

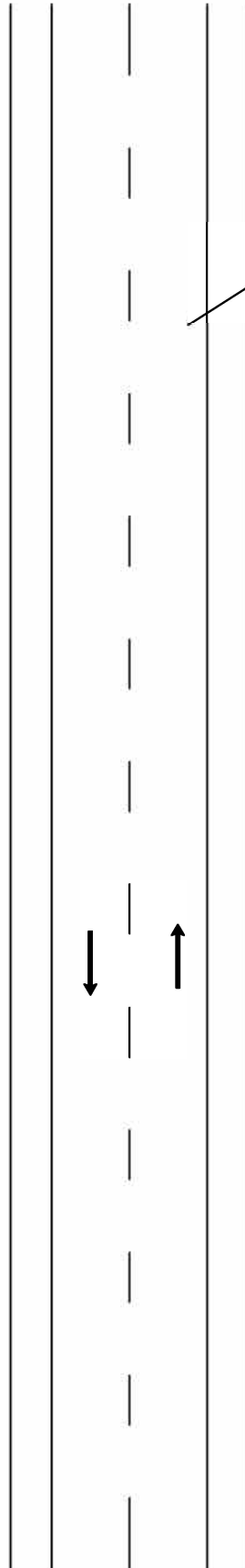



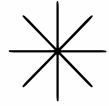



INDICATE NORTH



STREET NAME

LEGEND

-  CHANNELIZING DEVICE
-  SIGN STAND
-  WORK AREA
-  DIRECTION OF TRAVEL
-  TRUCK MOUNTED IMPACT ATTENUATOR
-  WORK VEHICLE

* FOR SIGN SPACING AND TAPER LENGTH REFER TO APPENDIX "D".

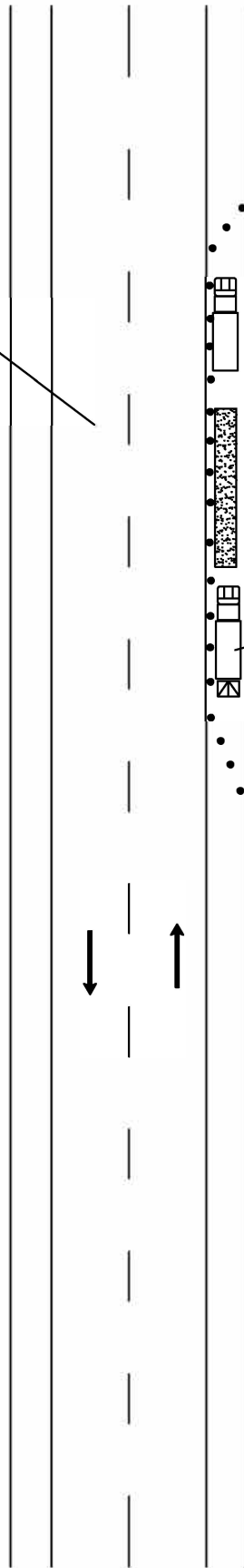

USE SAFETY FLASHERS OR ARROW PANEL IN CAUTION MODE.

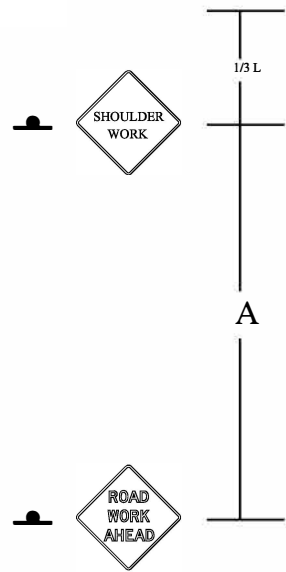

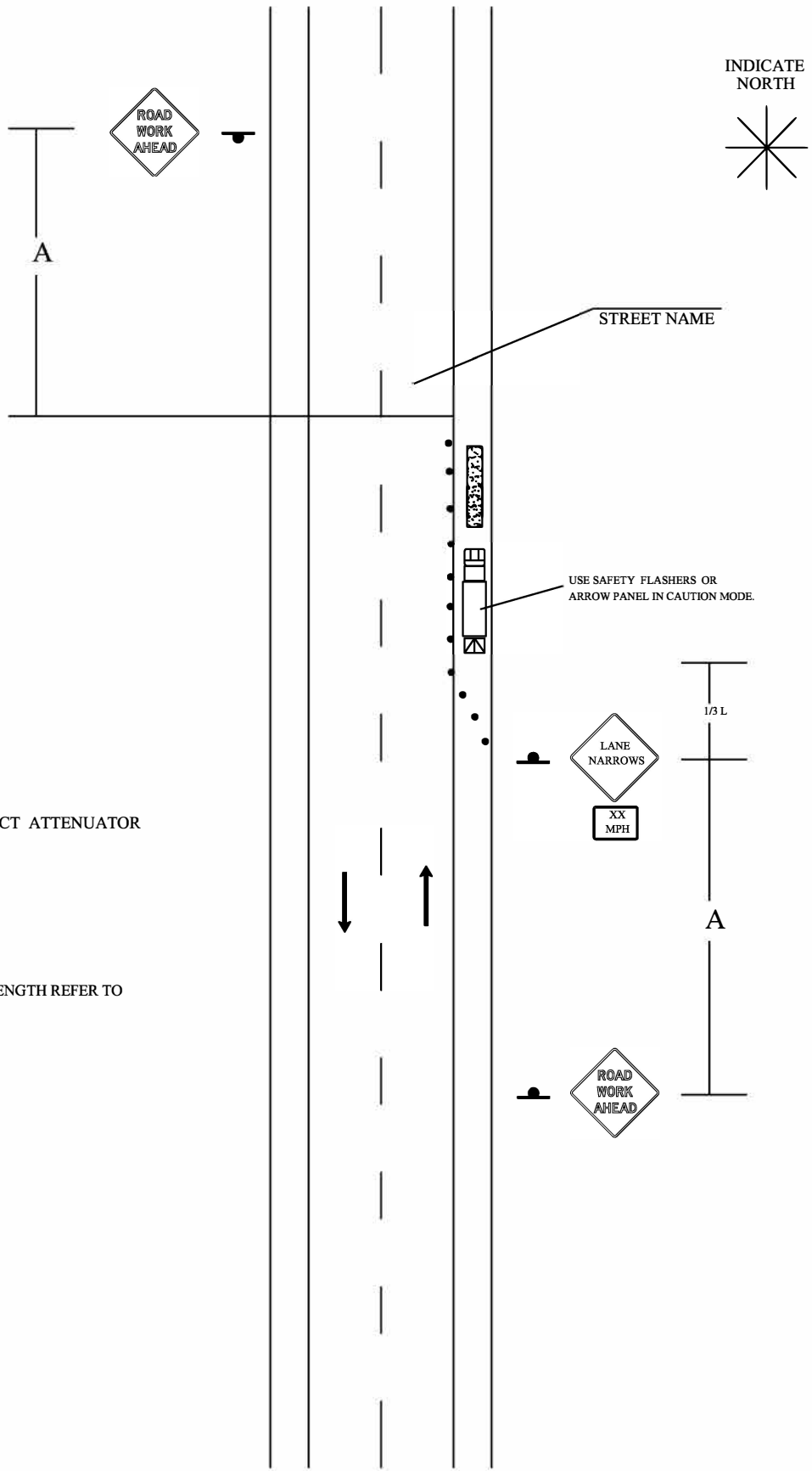

LEGEND

- CHANNELIZING DEVICE
- SIGN STAND
- ▨ WORK AREA
- ↑ DIRECTION OF TRAVEL
- ▢ TRUCK MOUNTED IMPACT ATTENUATOR
- ▣ WORK VEHICLE

* FOR SIGN SPACING AND TAPER LENGTH REFER TO APPENDIX "D".

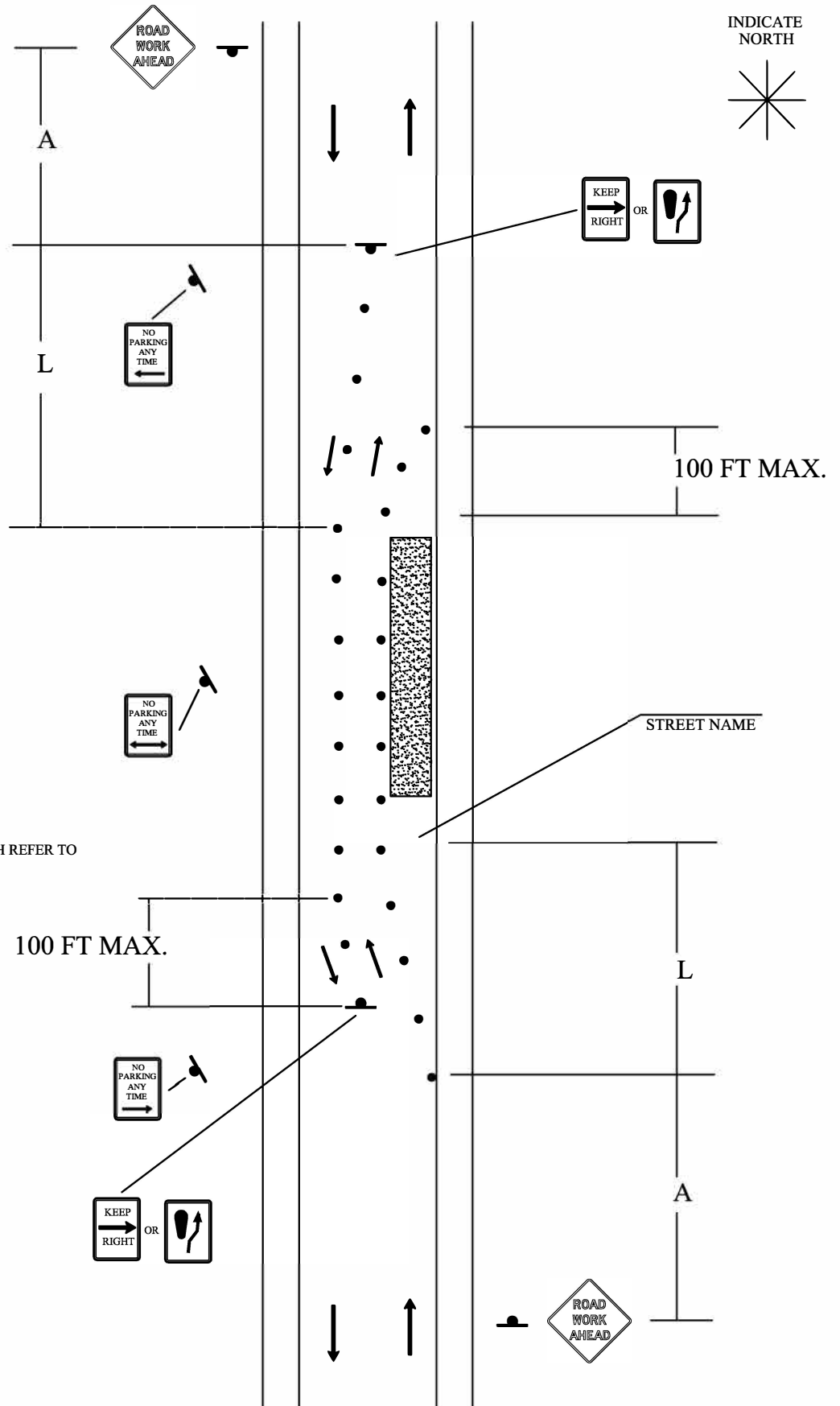

LEGEND

- CHANNELIZING DEVICE
- SIGN STAND
- ▨ WORK AREA
- ↑ DIRECTION OF TRAVEL

* FOR SIGN SPACING AND TAPER LENGTH REFER TO APPENDIX "D".

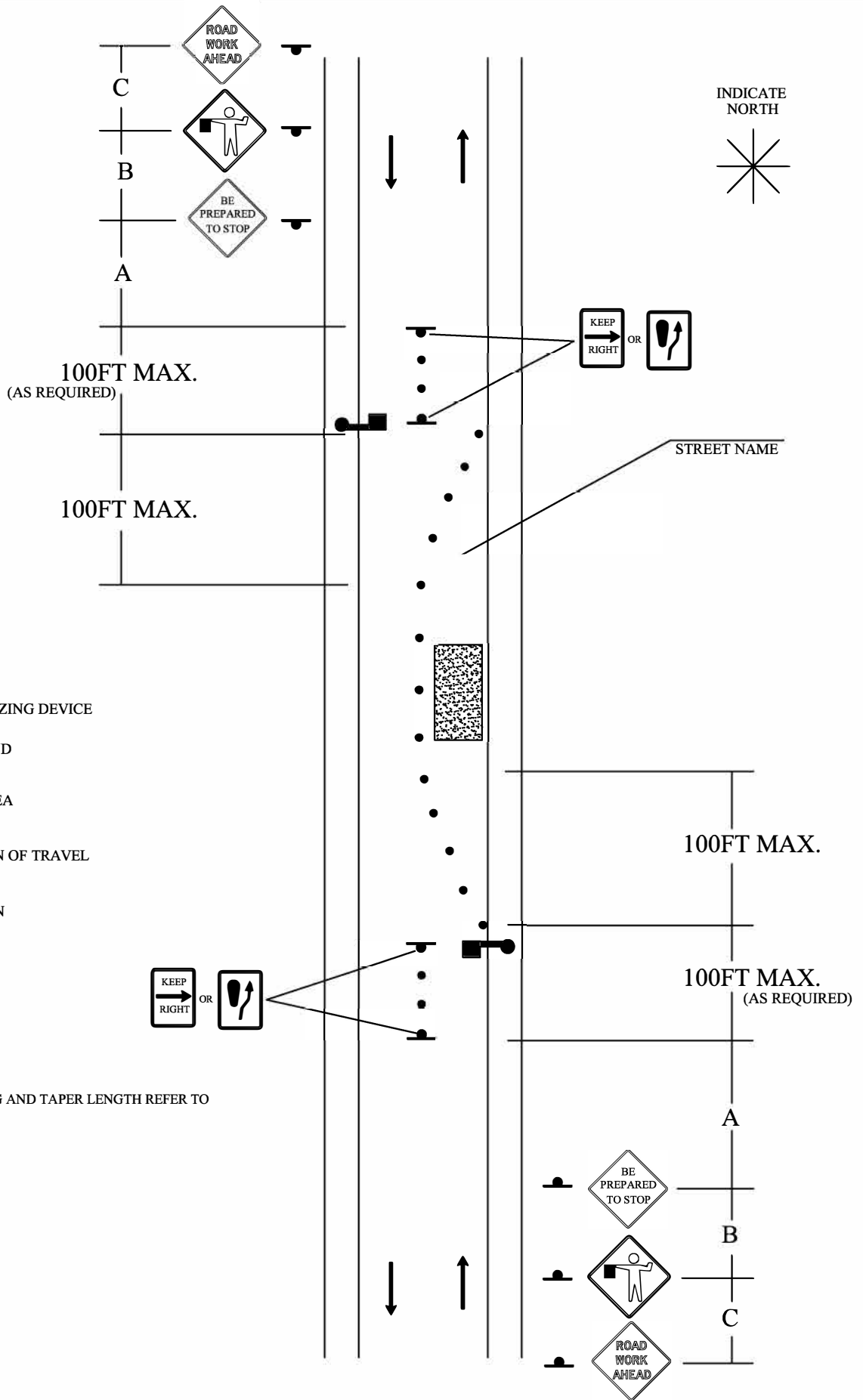

LEGEND

- CHANNELIZING DEVICE
- SIGN STAND
- ▒ WORK AREA
- ↑ DIRECTION OF TRAVEL
- FLAGMAN

* FOR SIGN SPACING AND TAPER LENGTH REFER TO APPENDIX "D".

INDICATE NORTH

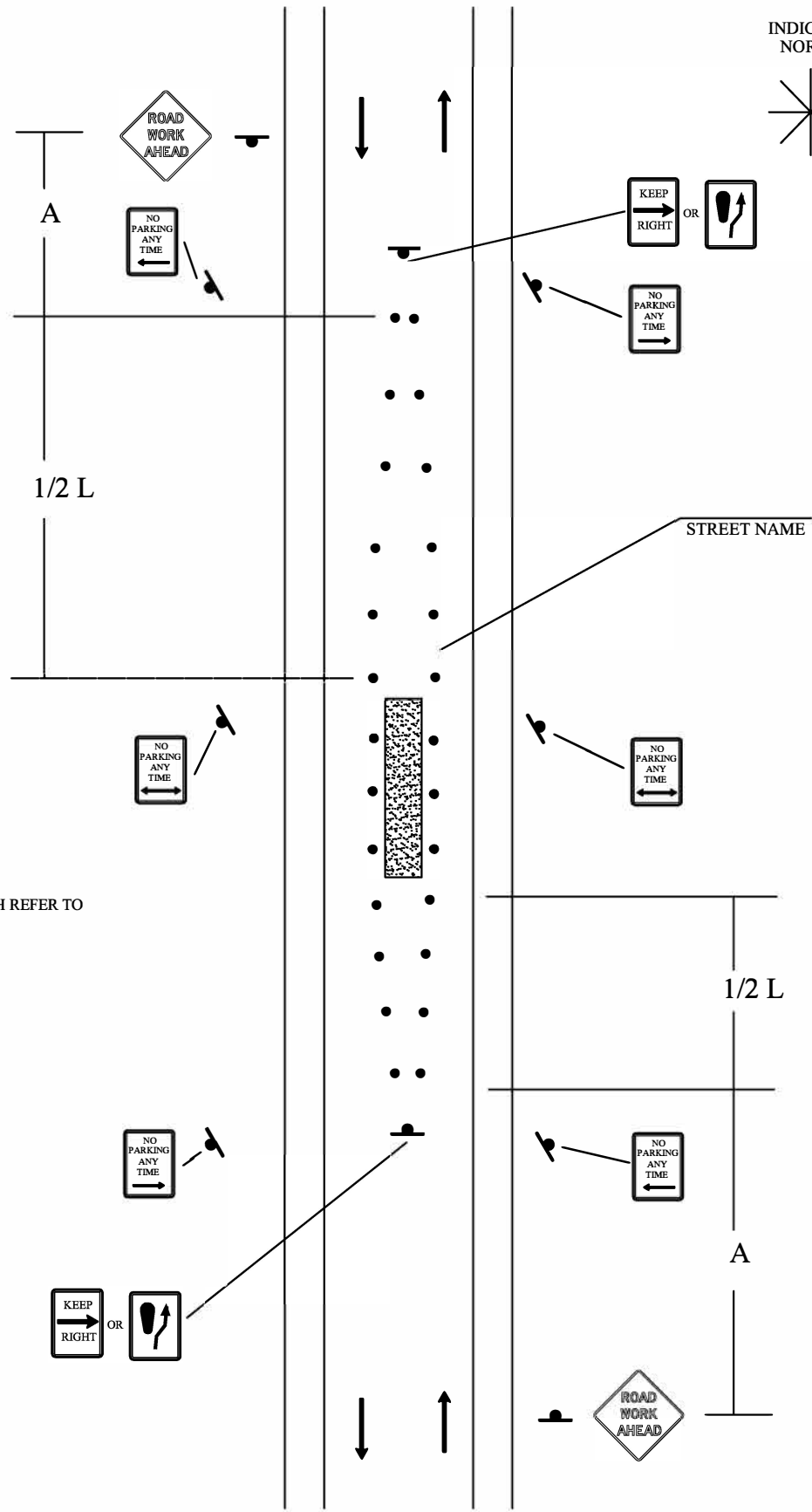
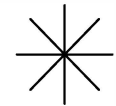

LEGEND

- CHANNELIZING DEVICE
- SIGN STAND
- ▨ WORK AREA
- ↑ DIRECTION OF TRAVEL

* FOR SIGN SPACING AND TAPER LENGTH REFER TO APPENDIX "C".

INDICATE NORTH

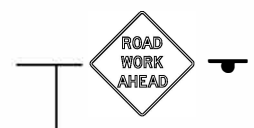
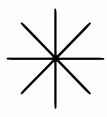

A

100 FT MAX.
(AS REQUIRED)

STREET NAME

LEGEND

- CHANNELIZING DEVICE
- SIGN STAND
- WORK AREA
- DIRECTION OF TRAVEL
- ARROW PANEL

* PLACEMENT OF THE ARROW PANEL SHOULD BE ON THE SHOULDER AT THE START OF THE CLOSURE AND IN THE CLOSED LANE IF NO SHOULDER IS AVAILABLE.

* FOR SIGN SPACING AND TAPER LENGTH REFER TO APPENDIX "C".



L

A

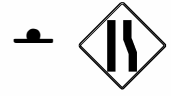

B



C

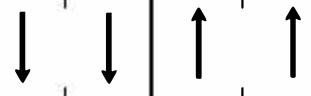

INDICATE NORTH

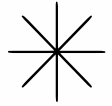

A

100 FT. MAX.

STREET NAME

LEGEND

- CHANNELIZING DEVICE
- SIGN STAND
- WORK AREA
- DIRECTION OF TRAVEL
- ARROW PANEL

* FOR SIGN SPACING AND TAPER LENGTH REFER TO APPENDIX "C".



L

A



B



C

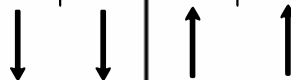

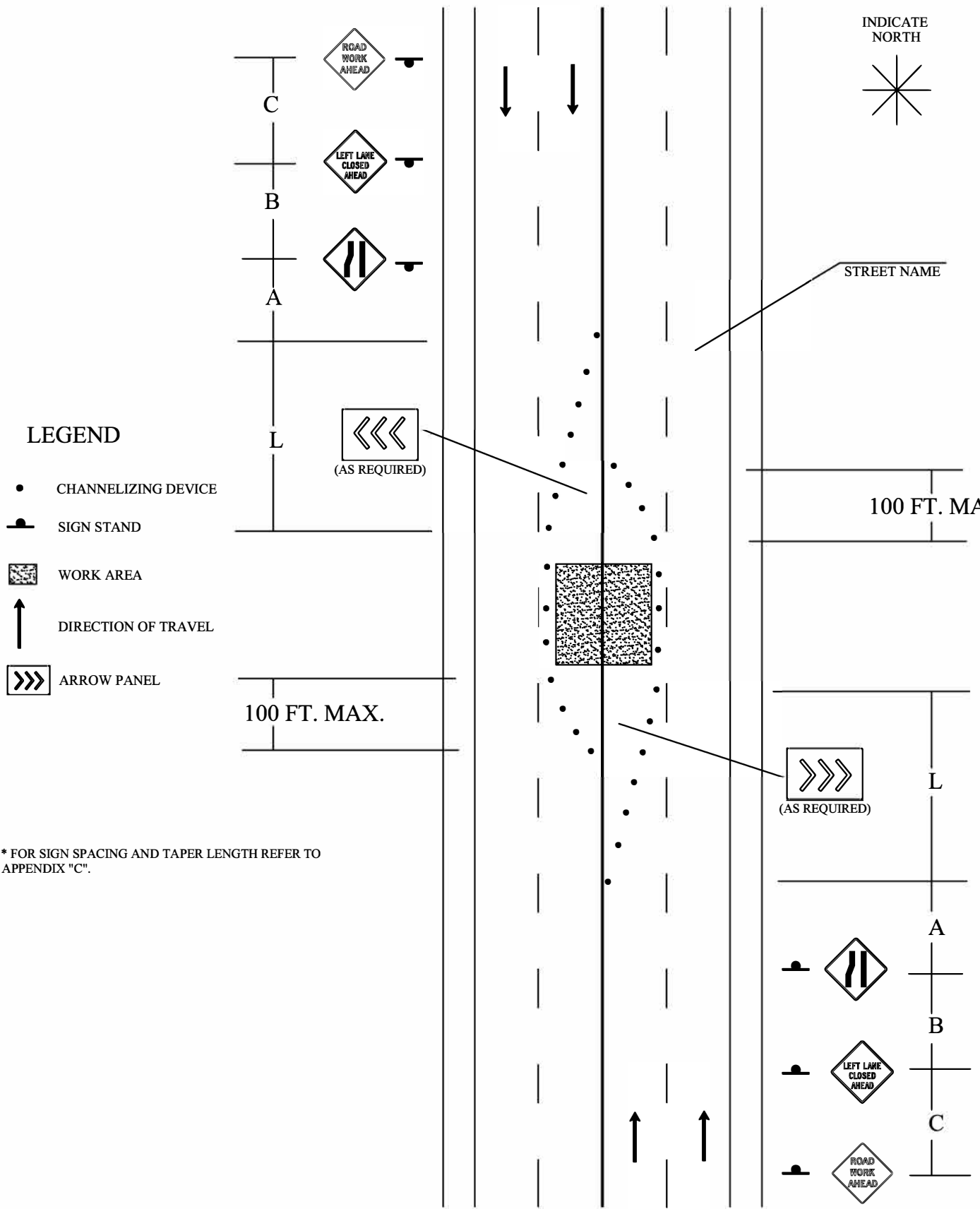

LEGEND

- CHANNELIZING DEVICE
- SIGN STAND
- ▨ WORK AREA
- ↑ DIRECTION OF TRAVEL
- ARROW PANEL

* FOR SIGN SPACING AND TAPER LENGTH REFER TO APPENDIX "C".

INDICATE NORTH

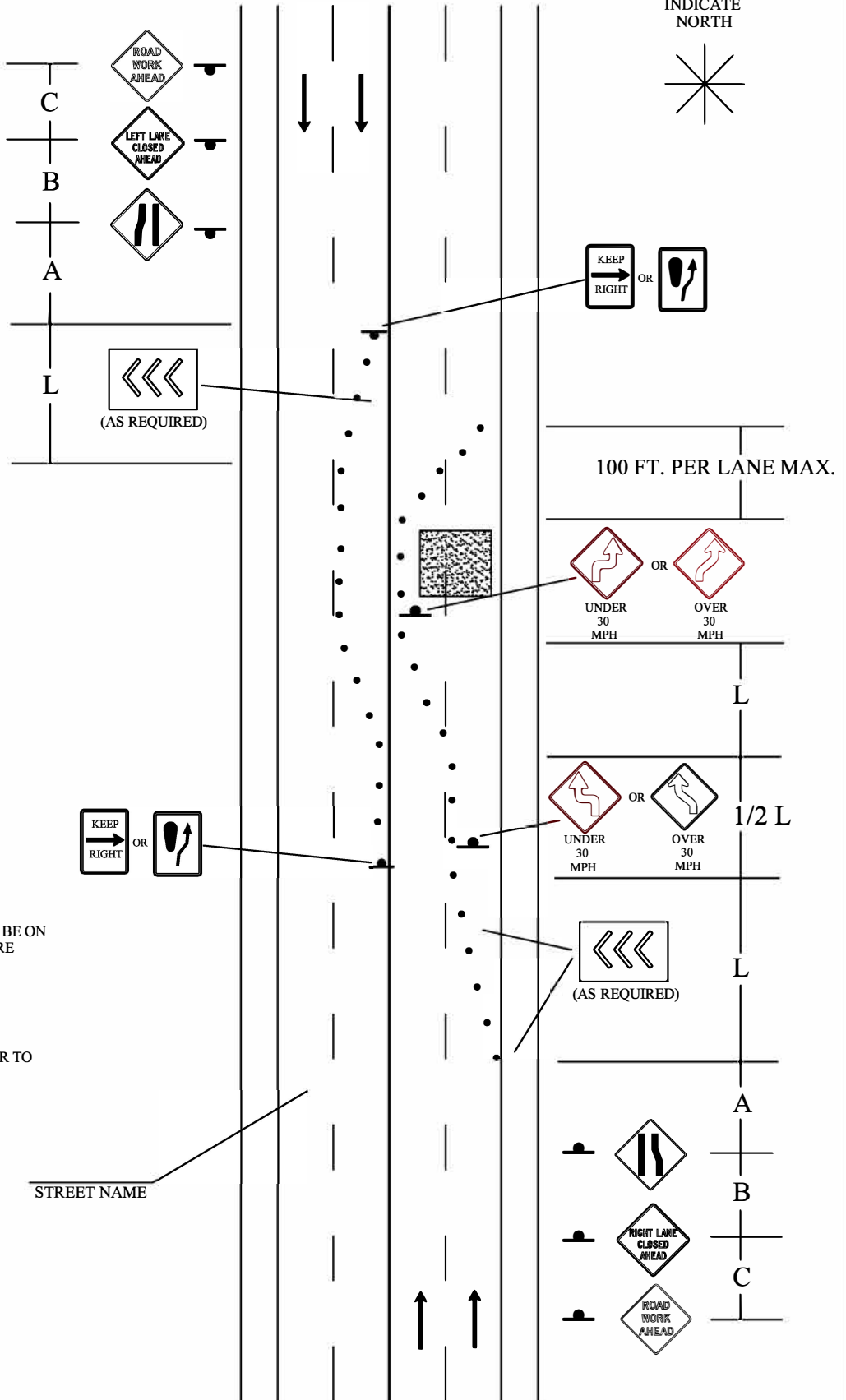
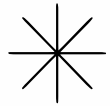

LEGEND

- CHANNELIZING DEVICE
- SIGN STAND
- WORK AREA
- ↑ DIRECTION OF TRAVEL
- ARROW PANEL

* PLACEMENT OF THE ARROW PANEL SHOULD BE ON THE SHOULDER AT THE START OF THE CLOSURE AND IN THE CLOSED LANE IF NO SHOULDER IS AVAILABLE.

* FOR SIGN SPACING AND TAPER LENGTH REFER TO APPENDIX "C".

INDICATE NORTH

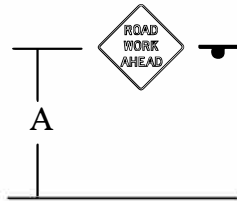
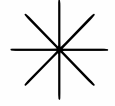

LEGEND

- CHANNELIZING DEVICE
- SIGN STAND
- WORK AREA
- DIRECTION OF TRAVEL
- ARROW PANEL

* PLACEMENT OF THE ARROW PANEL SHOULD BE ON THE SHOULDER AT THE START OF THE CLOSURE AND IN THE CLOSED LANE IF NO SHOULDER IS AVAILABLE.

* FOR SIGN SPACING AND TAPER LENGTH REFER TO APPENDIX "C".

100 FT. MAX.
(AS REQUIRED)

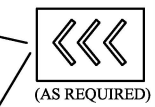

L

A



B



C



STREET NAME



INDICATE NORTH

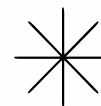

LEGEND

- CHANNELIZING DEVICE
- SIGN STAND
- WORK AREA
- DIRECTION OF TRAVEL
- ARROW PANEL

* FOR SIGN SPACING AND TAPER LENGTH REFER TO APPENDIX "C".

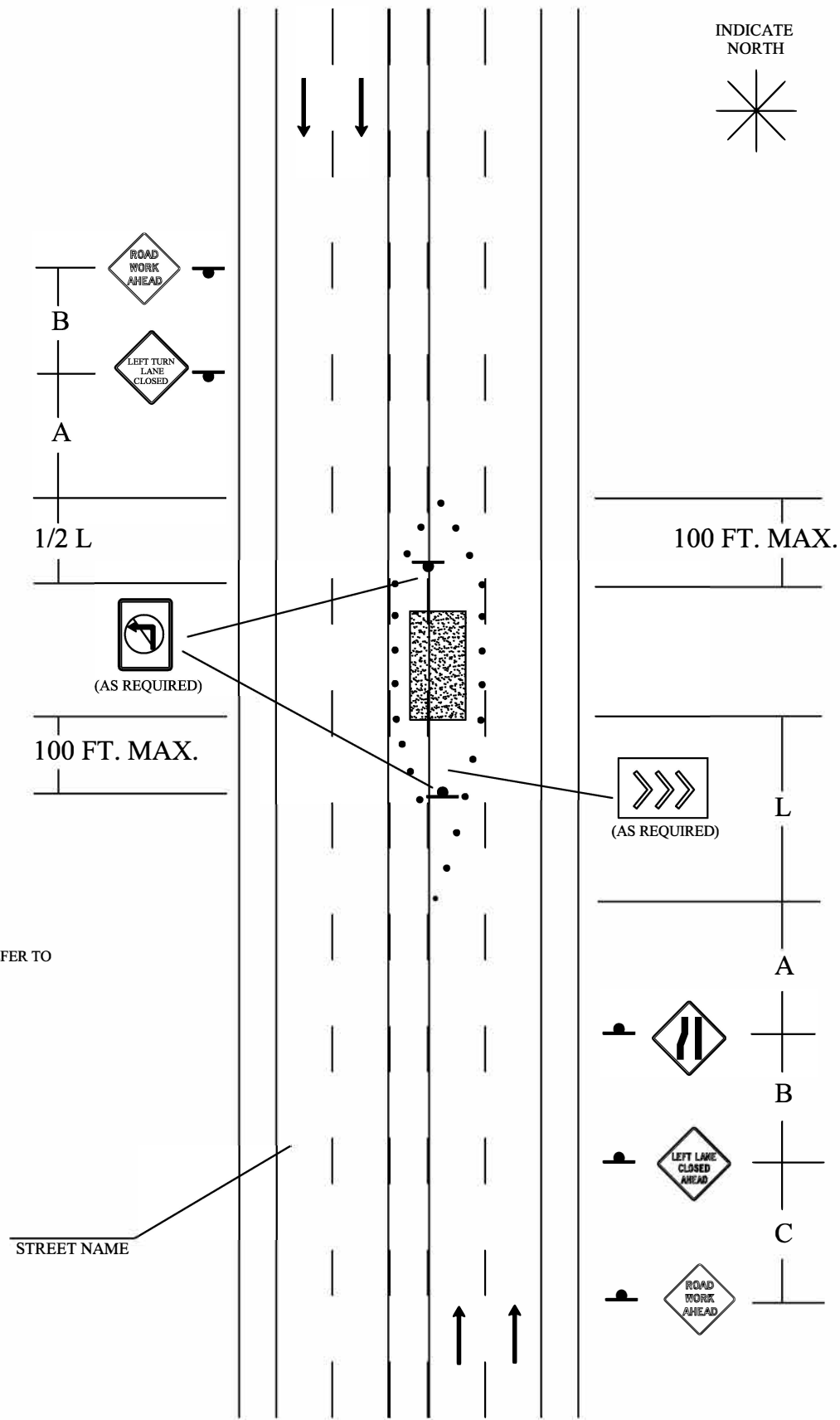

INDICATE NORTH

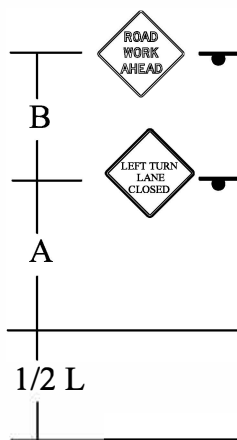
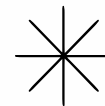

LEGEND

- CHANNELIZING DEVICE
- SIGN STAND
- ▨ WORK AREA
- ↑ DIRECTION OF TRAVEL

* FOR SIGN SPACING AND TAPER LENGTH REFER TO APPENDIX "C".

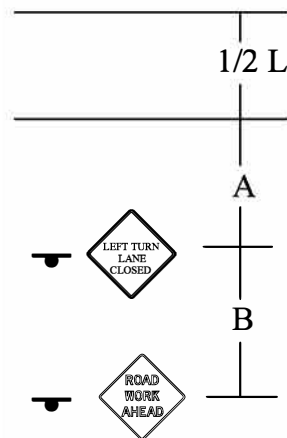
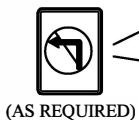

STREET NAME

INDICATE NORTH

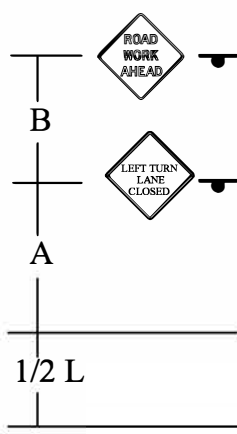
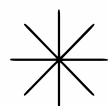

100 FT. PER LANE MAX.

LEGEND

- CHANNELIZING DEVICE
- SIGN STAND
- ▒ WORK AREA
- ↑ DIRECTION OF TRAVEL
- ARROW PANEL

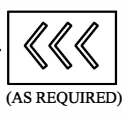
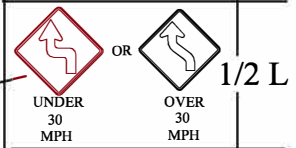
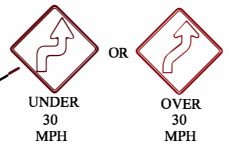
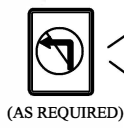

* PLACEMENT OF THE ARROW PANEL SHOULD BE ON THE SHOULDER AT THE START OF THE CLOSURE AND IN THE CLOSED LANE IF NO SHOULDER IS AVAILABLE.

* FOR SIGN SPACING AND TAPER LENGTH REFER TO APPENDIX "C".

STREET NAME

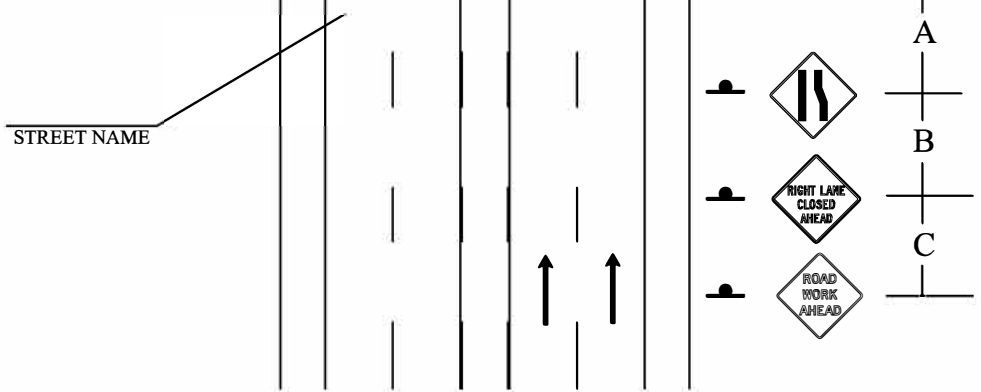

INDICATE NORTH

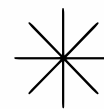

RAISED MEDIAN

LEGEND

- CHANNELIZING DEVICE
- SIGN STAND
- WORK AREA
- DIRECTION OF TRAVEL
- ARROW PANEL

* FOR SIGN SPACING AND TAPER LENGTH REFER TO APPENDIX "C".

STREET NAME

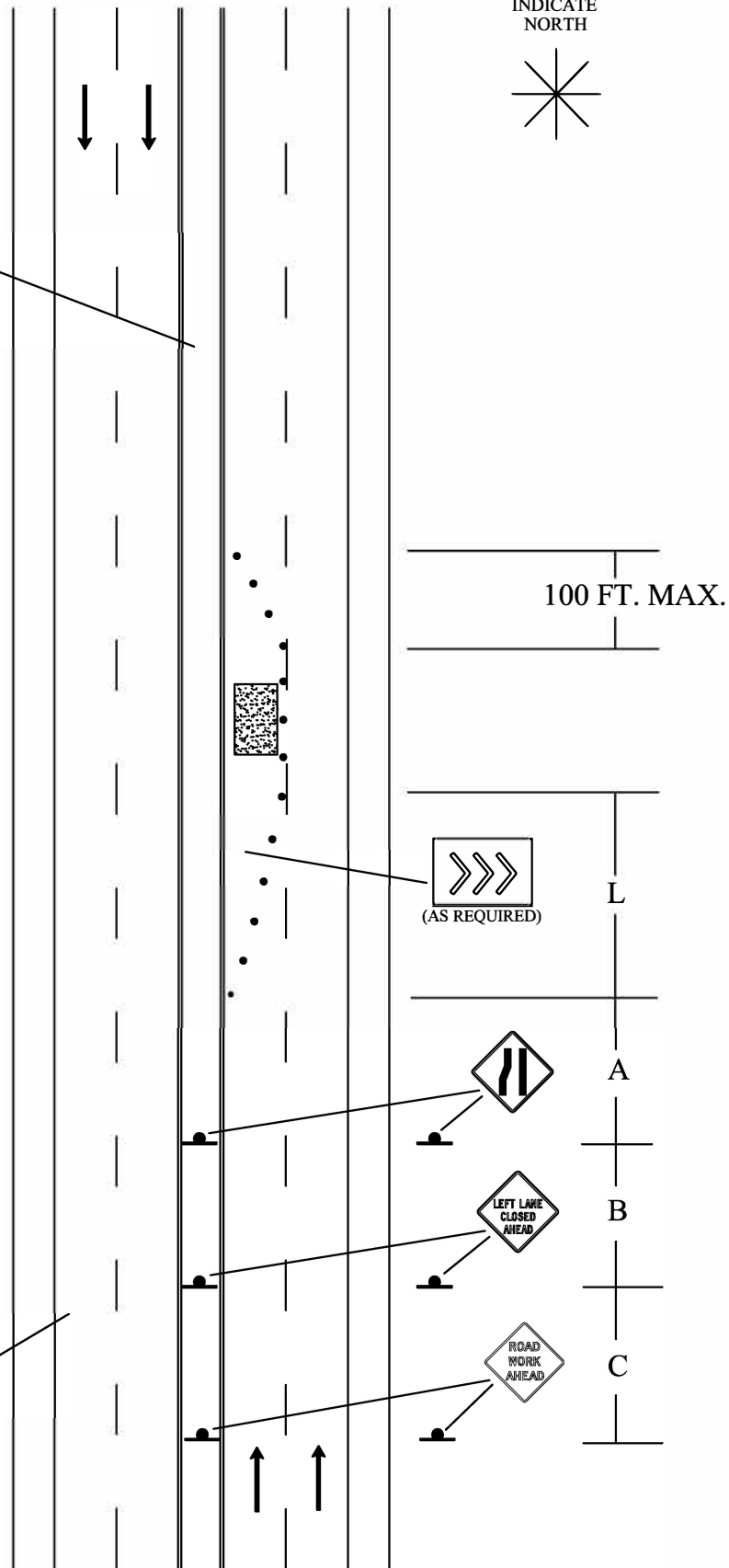

INDICATE NORTH

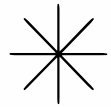

RAISED MEDIAN

LEGEND

- CHANNELIZING DEVICE
- SIGN STAND
- WORK AREA
- DIRECTION OF TRAVEL
- ARROW PANEL

* PLACEMENT OF THE ARROW PANEL SHOULD BE ON THE SHOULDER AT THE START OF THE CLOSURE AND IN THE CLOSED LANE IF NO SHOULDER IS AVAILABLE.

* FOR SIGN SPACING AND TAPER LENGTH REFER TO APPENDIX "D".

STREET NAME

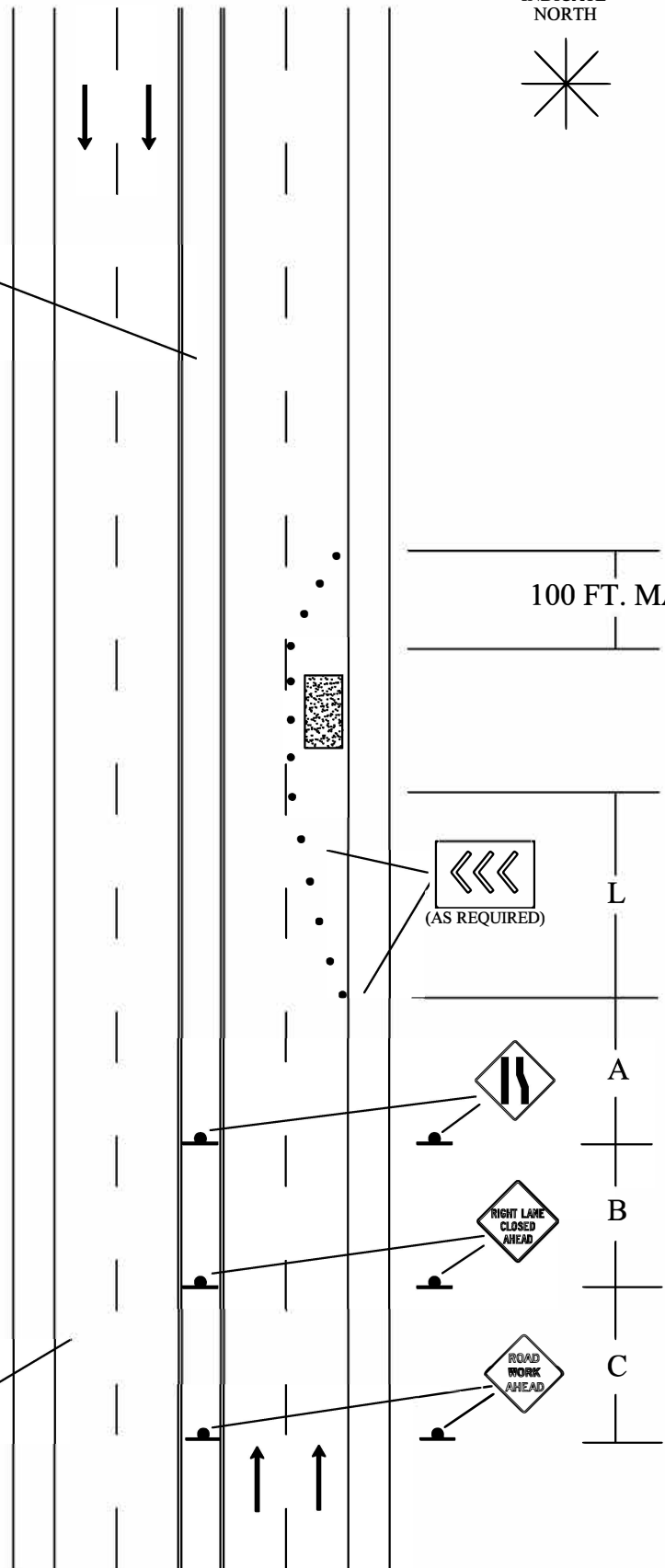

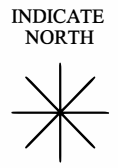

100 FT. MAX.
(AS REQUIRED)

STREET NAME

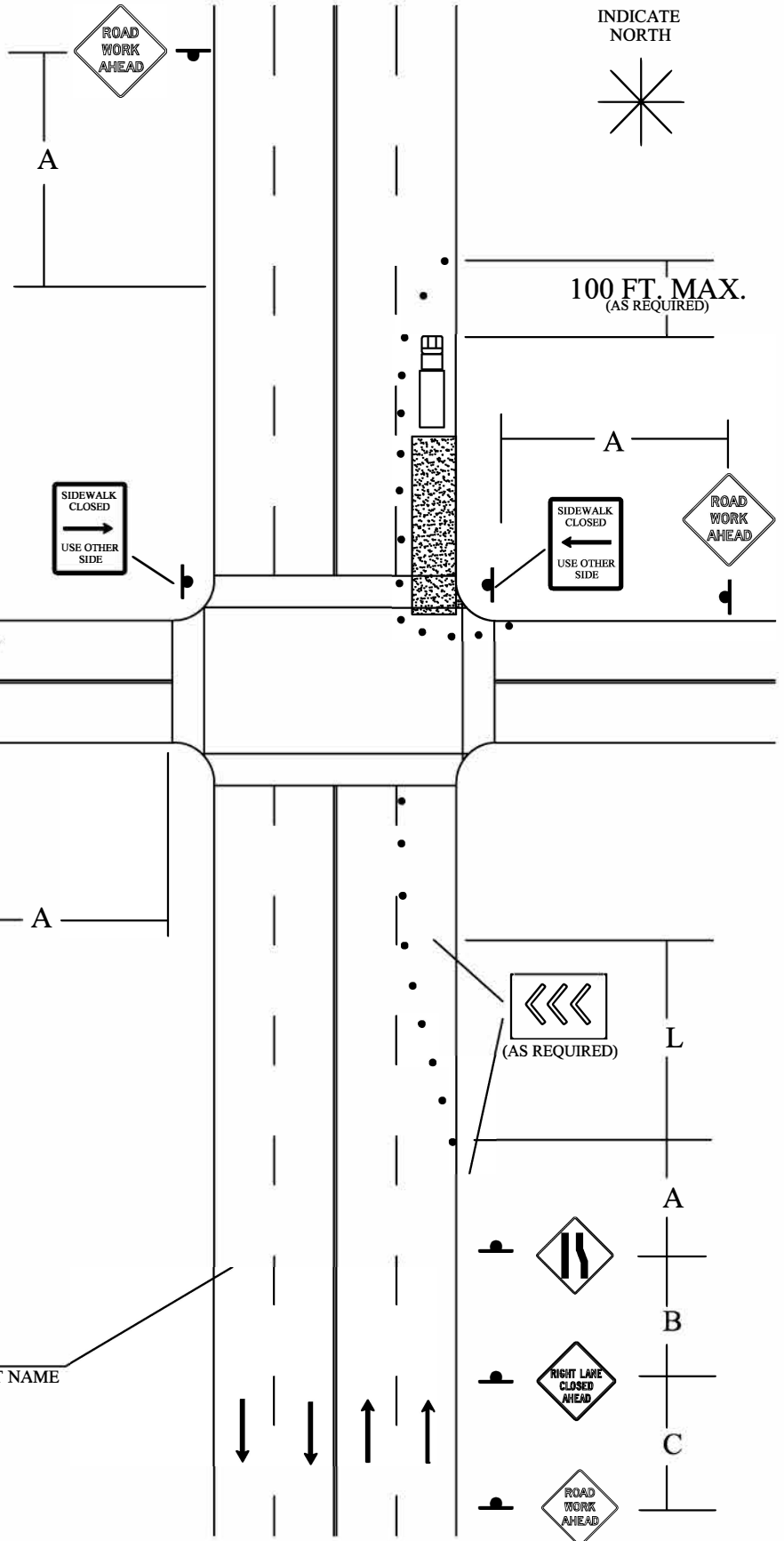

LEGEND

- CHANNELIZING DEVICE
- SIGN STAND
- ▨ WORK AREA
- ↑ DIRECTION OF TRAVEL
- ◀◀◀ ARROW PANEL
- 🚚 WORK VEHICLE

* PLACEMENT OF THE ARROW PANEL SHOULD BE ON THE SHOULDER AT THE START OF THE CLOSURE AND IN THE CLOSED LANE IF NO SHOULDER IS AVAILABLE.

* FOR SIGN SPACING AND TAPER LENGTH REFER TO APPENDIX "D".

STREET NAME

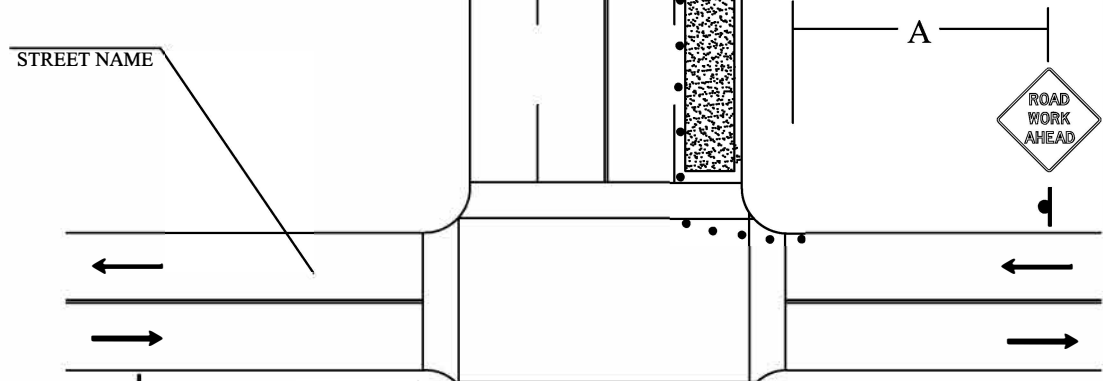
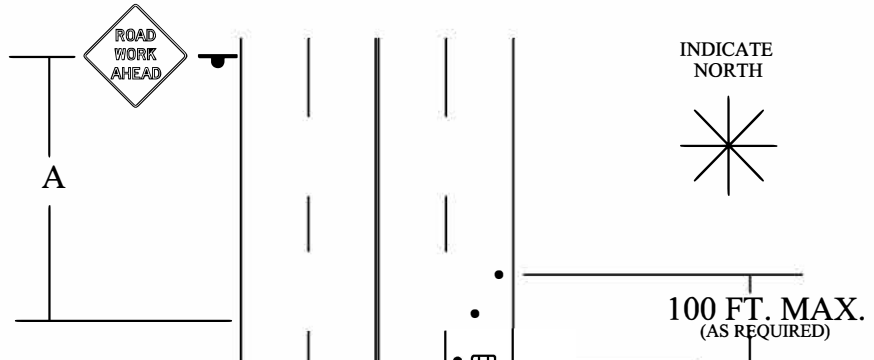

LEGEND

- CHANNELIZING DEVICE
- SIGN STAND
- ▨ WORK AREA
- ↑ DIRECTION OF TRAVEL
- ◀◀◀ ARROW PANEL
- ▭ WORK VEHICLE

* PLACEMENT OF THE ARROW PANEL SHOULD BE ON THE SHOULDER AT THE START OF THE CLOSURE AND IN THE CLOSED LANE IF NO SHOULDER IS AVAILABLE.

* FOR SIGN SPACING AND TAPER LENGTH REFER TO APPENDIX "D".

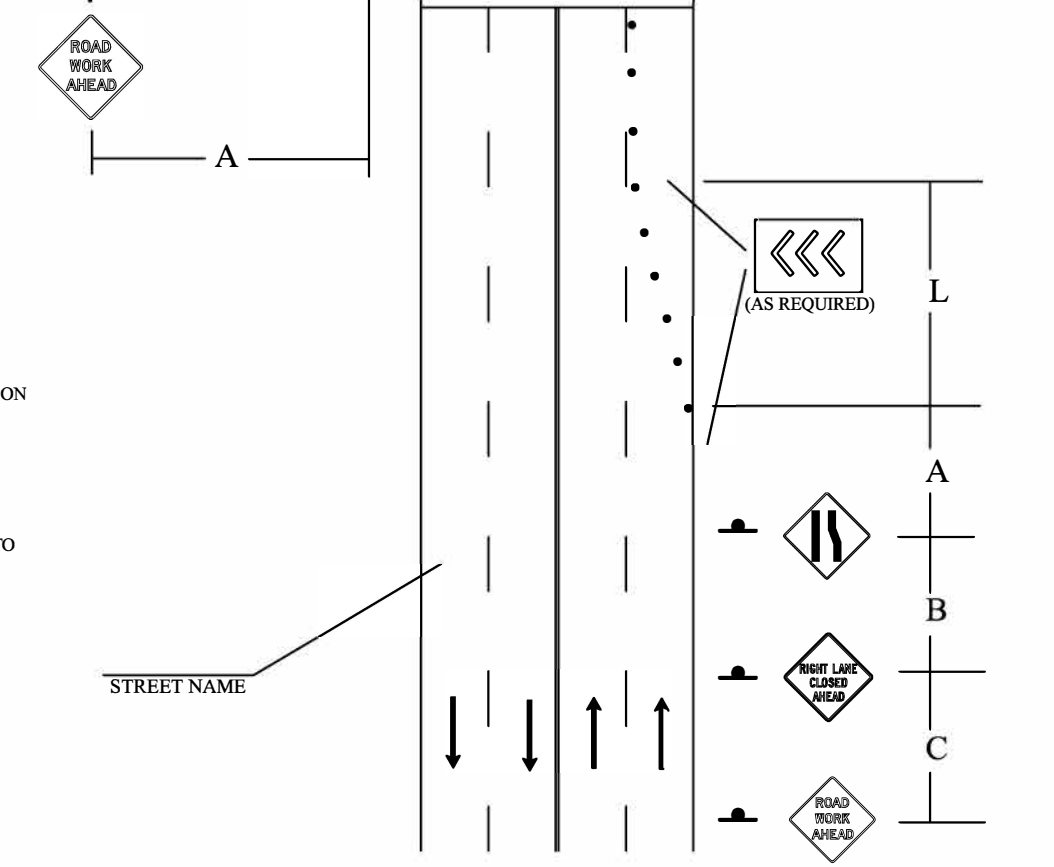

INDICATE NORTH

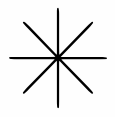

100 FT. MAX.

STREET NAME

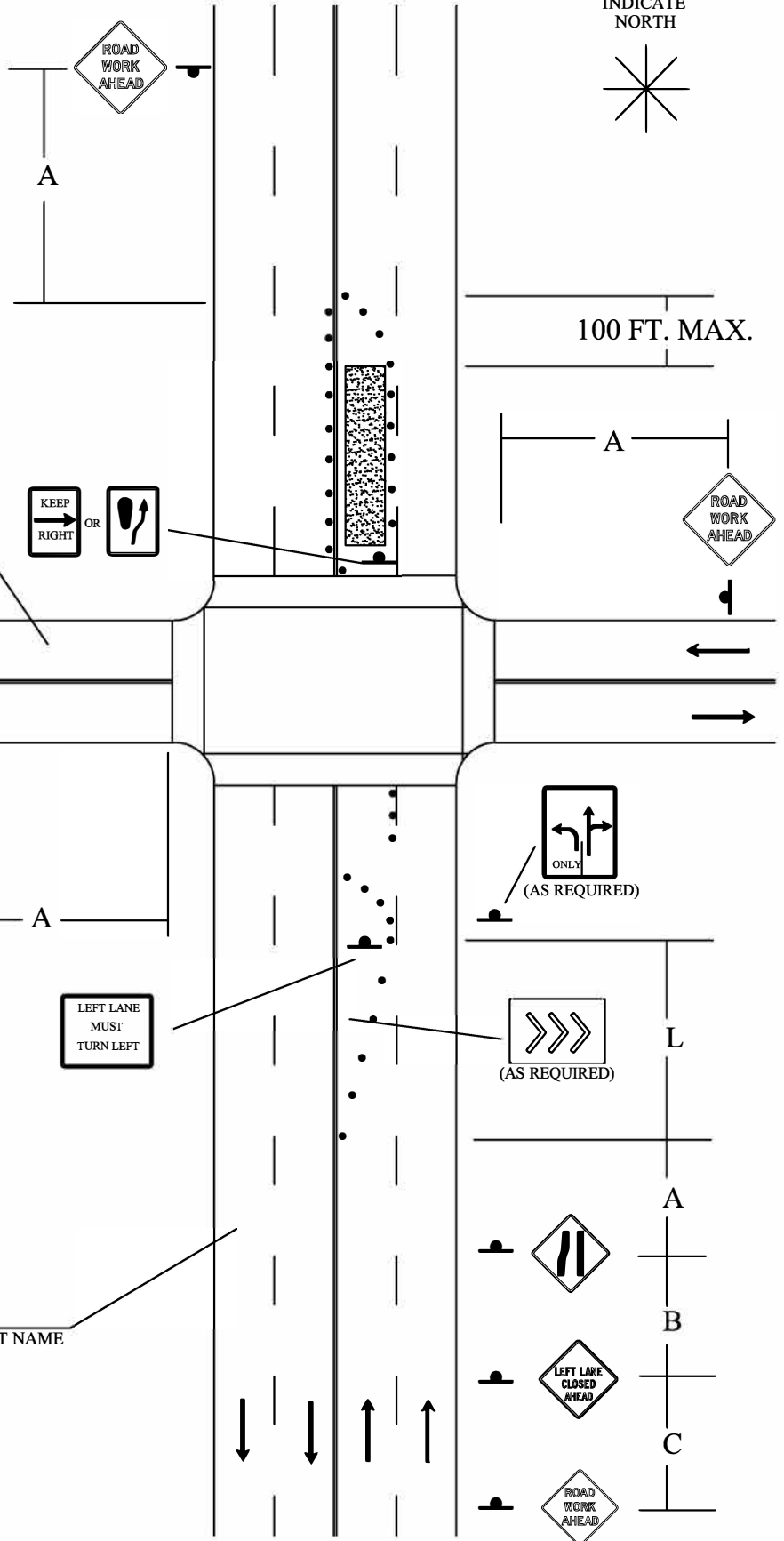

LEGEND

- CHANNELIZING DEVICE
- SIGN STAND
- WORK AREA
- DIRECTION OF TRAVEL
- ARROW PANEL

* THE LENGTH OF THE TURN BAY IS DEPENDANT ON THE SPEED AND AMOUNT OF TURNING VEHICLES AND WILL BE DETERMINED ON A PROJECT BY PROJECT BASIS.

* FOR SIGN SPACING AND TAPER LENGTH REFER TO APPENDIX "D".

STREET NAME

INDICATE NORTH

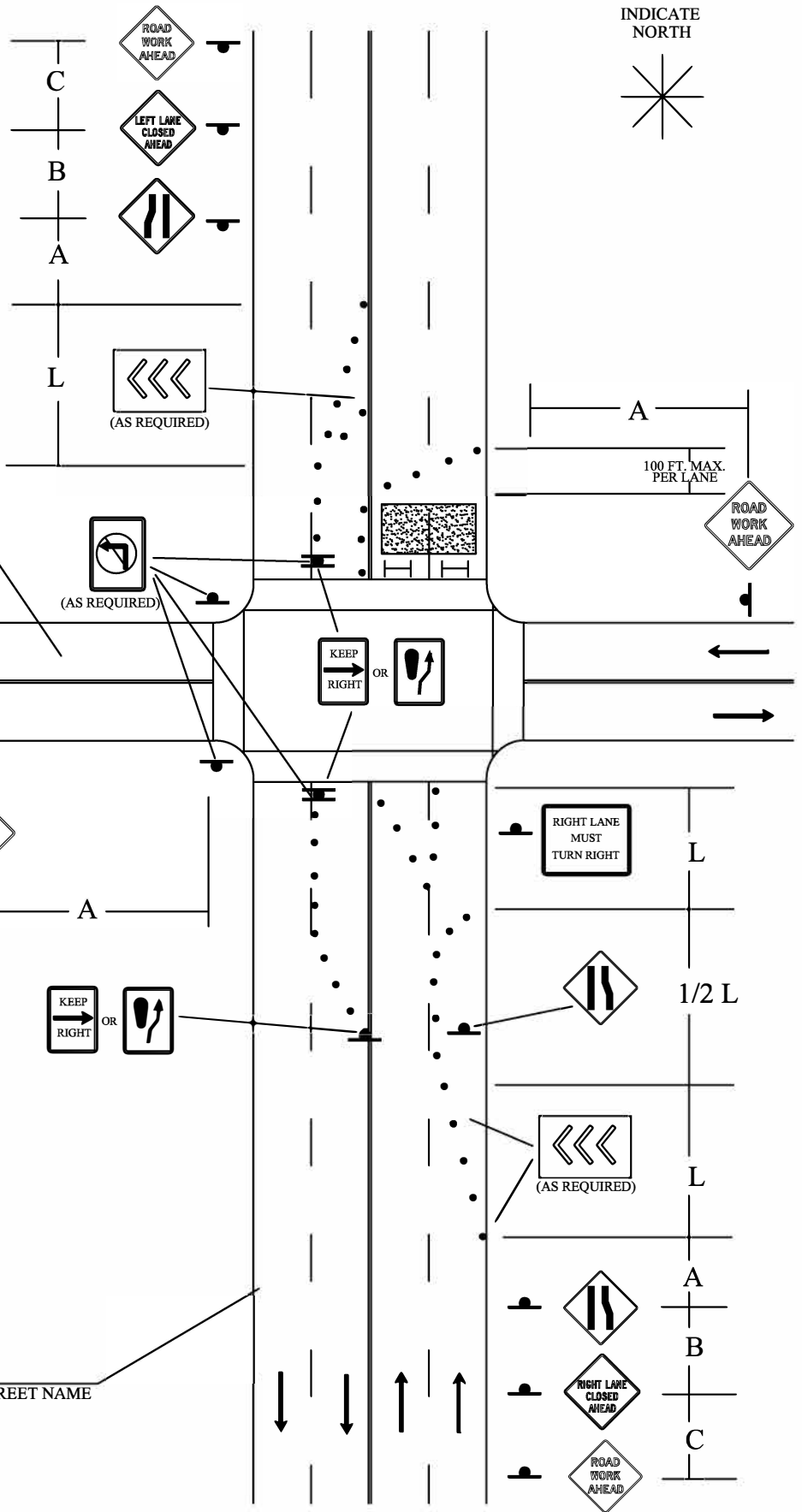
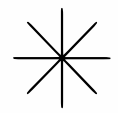

LEGEND

- CHANNELIZING DEVICE
- SIGN STAND
- ▨ WORK AREA
- ↑ DIRECTION OF TRAVEL
- ◀◀◀ ARROW PANEL
- TYPE I OR II BARRICADE

* THE LENGTH OF THE TURN BAY IS DEPENDANT ON THE SPEED AND AMOUNT OF TURNING VEHICLES AND WILL BE DETERMINED ON A PROJECT BY PROJECT BASIS.

* PLACEMENT OF THE ARROW PANEL SHOULD BE ON THE SHOULDER AT THE START OF THE CLOSURE AND IN THE CLOSED LANE IF NO SHOULDER IS AVAILABLE.

* FOR SIGN SPACING AND TAPER LENGTH REFER TO APPENDIX "D".

INDICATE NORTH

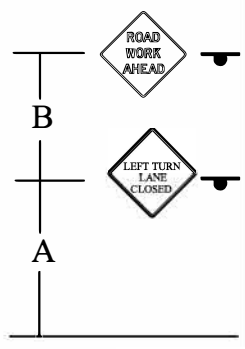
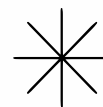

100 FT. MAX.

STREET NAME

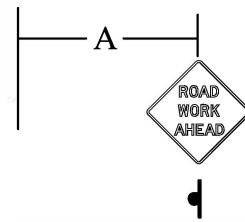
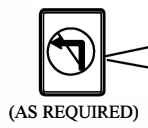

LEGEND

- CHANNELIZING DEVICE
- SIGN STAND
- ▨ WORK AREA
- ↑ DIRECTION OF TRAVEL
- ◀◀◀ ARROW PANEL
- TYPE I OR II BARRICADE

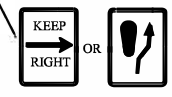
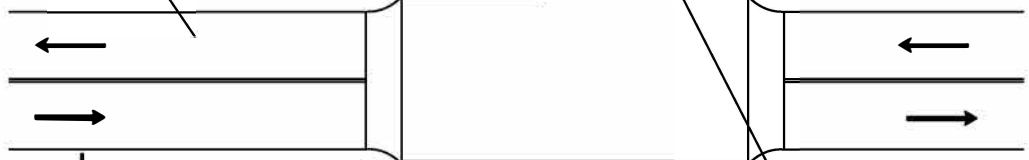

* FOR SIGN SPACING AND TAPER LENGTH REFER TO APPENDIX "D".

STREET NAME

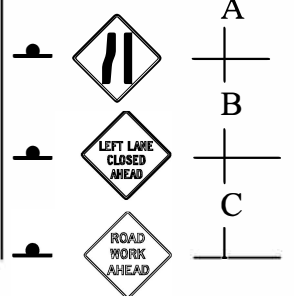
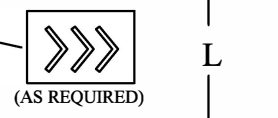

INDICATE NORTH

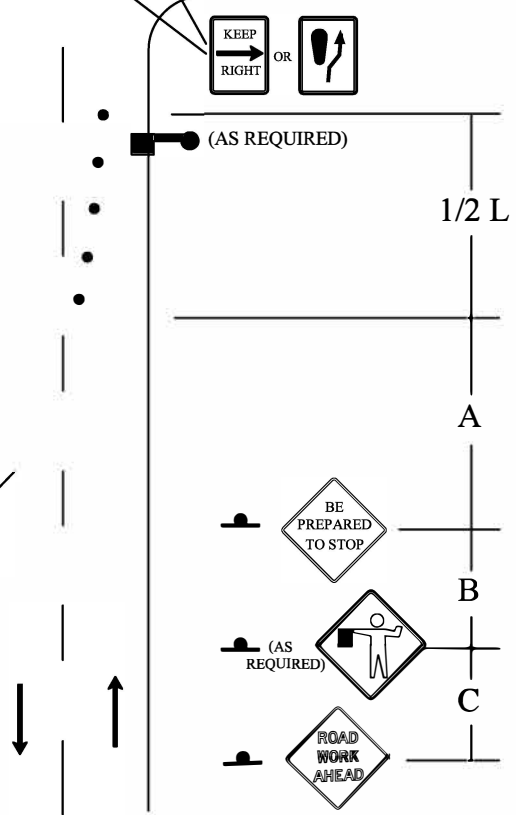
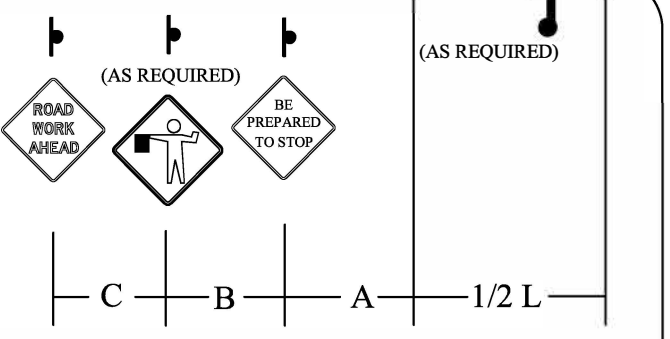
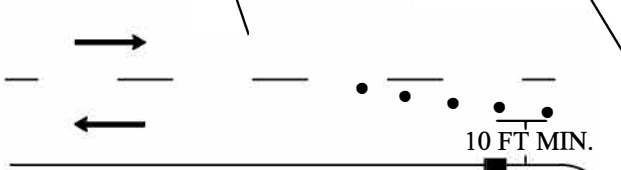
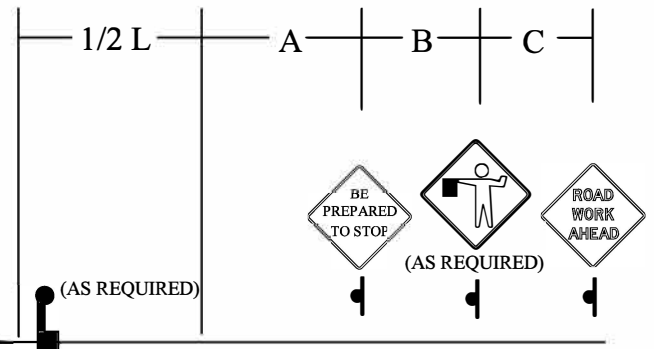
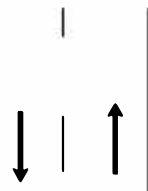
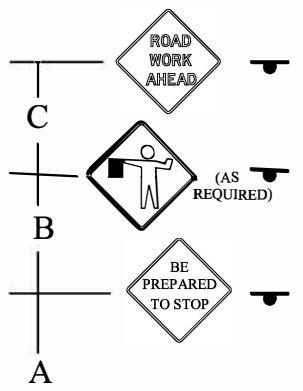
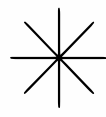

LEGEND

- CHANNELIZING DEVICE
- SIGN STAND
- ▨ WORK AREA
- ↑ DIRECTION OF TRAVEL
- FLAGMAN



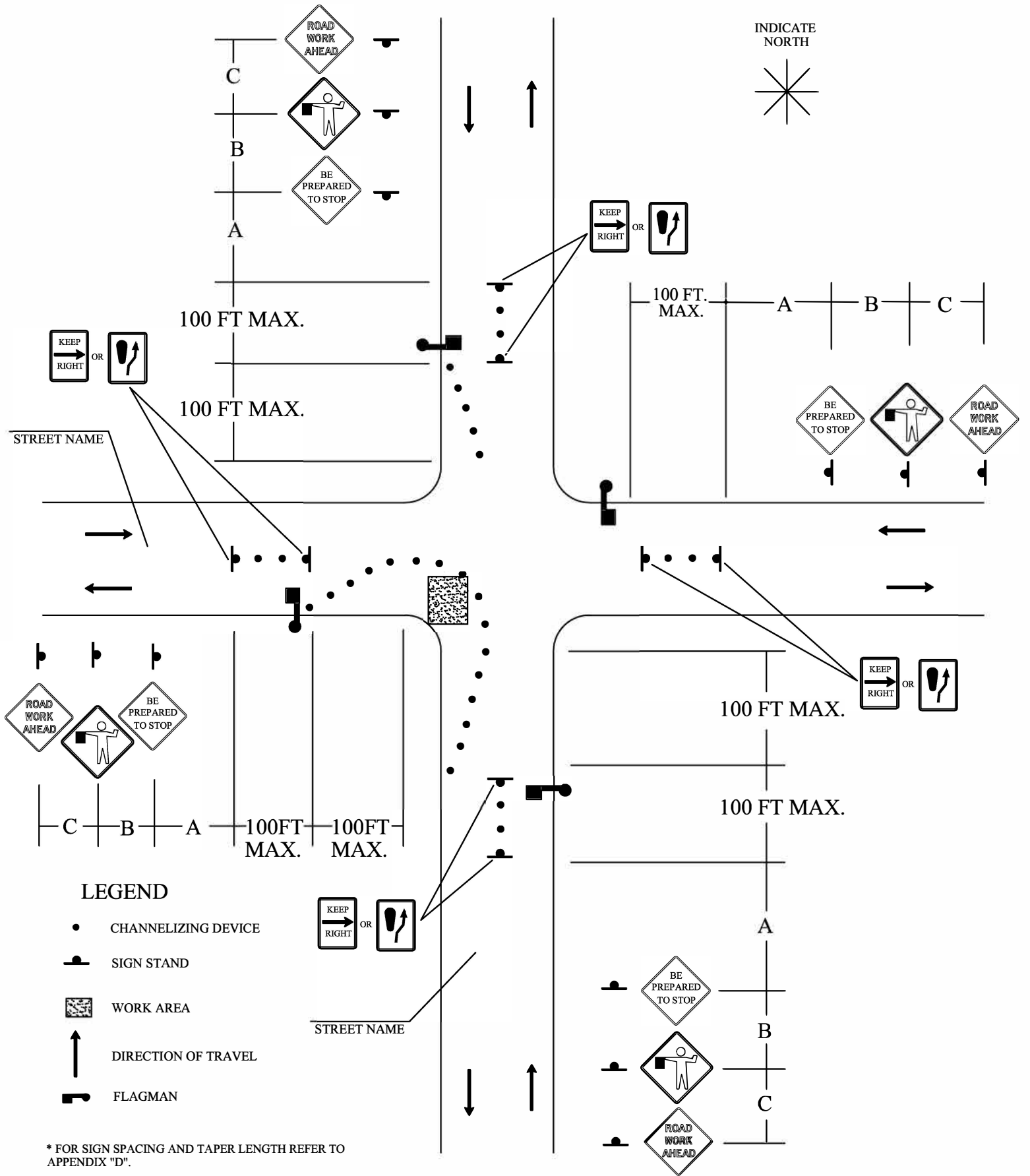

* FOR SIGN SPACING AND TAPER LENGTH REFER TO APPENDIX "D".

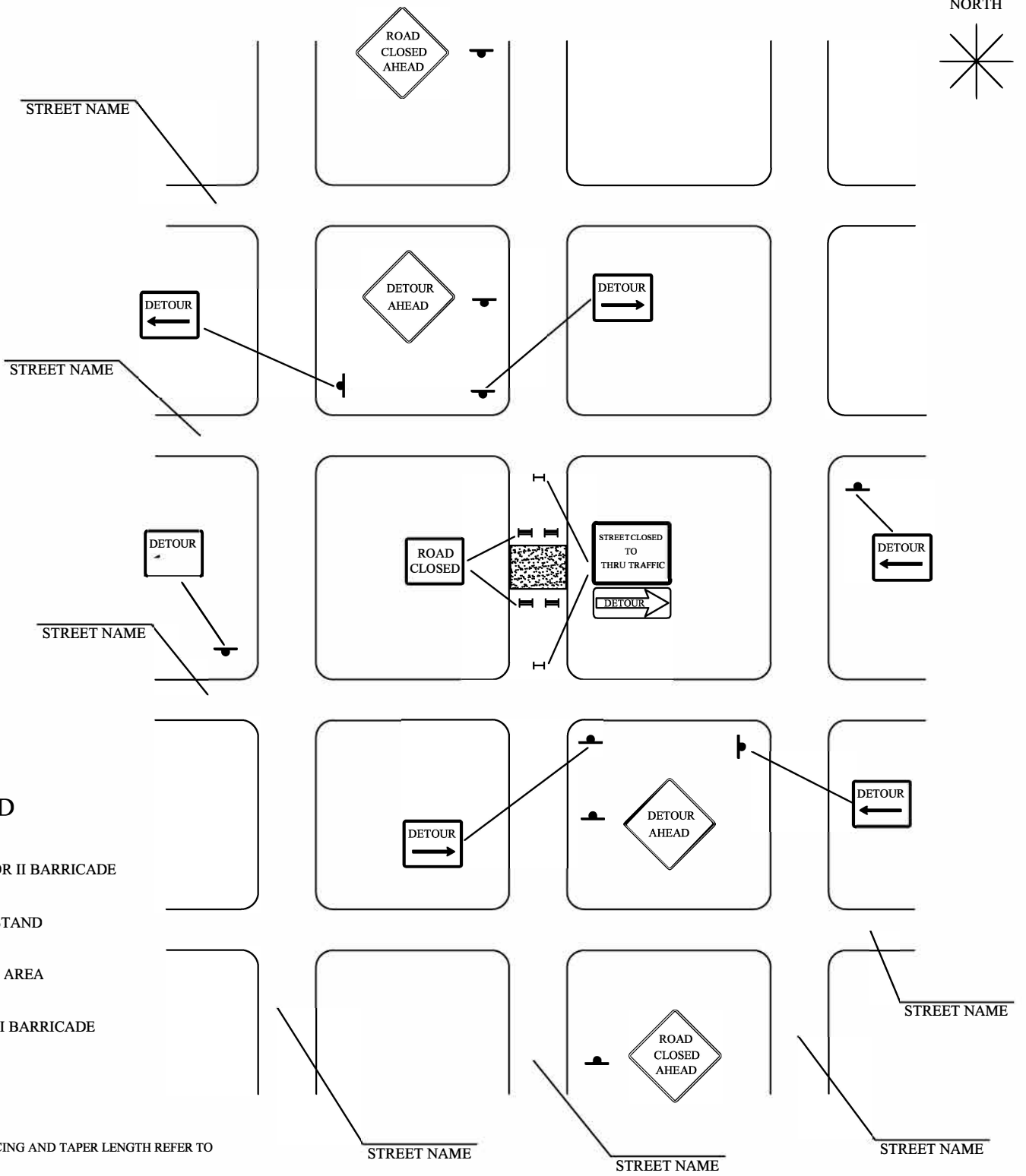
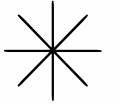

INDICATE NORTH



LEGEND

-  TYPE I OR II BARRICADE
-  SIGN STAND
-  WORK AREA
-  TYPE III BARRICADE

* FOR SIGN SPACING AND TAPER LENGTH REFER TO APPENDIX "D".

INDICATE NORTH

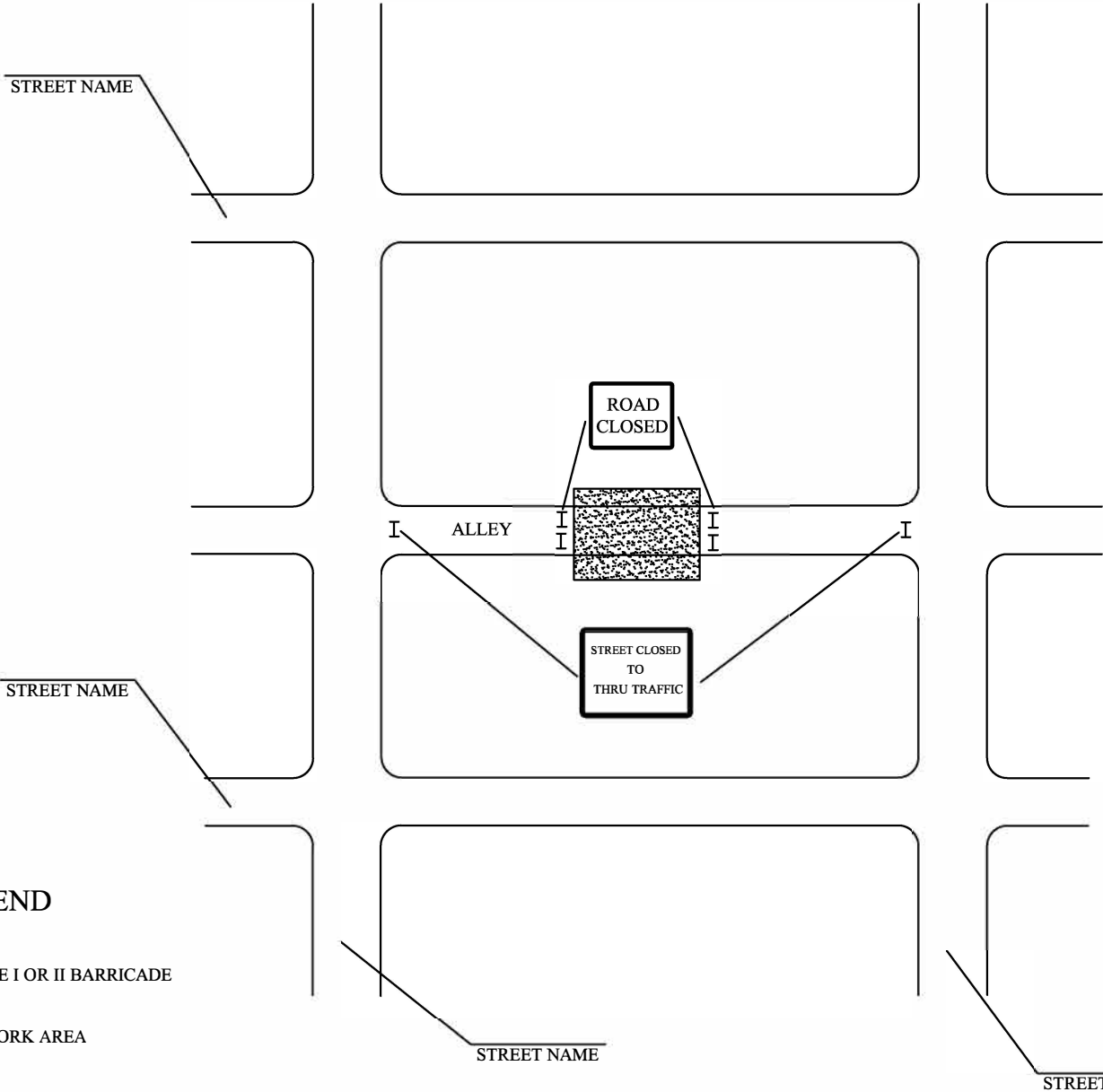
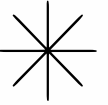

LEGEND

I TYPE I OR II BARRICADE

 WORK AREA

* FOR SIGN SPACING AND TAPER LENGTH REFER TO APPENDIX "D".

INDICATE NORTH

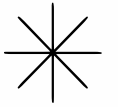

STREET NAME

LEGEND

⊥ TYPE I OR II BARRICADE

■ SIGN STAND

▨ WORK AREA

≡ TYPE III BARRICADE

ROAD CLOSED

STREET CLOSED TO THRU TRAFFIC

STREET NAME

* THIS TRAFFIC PLAN SHALL BE USED ONLY FOR LOW-SPEED STREETS HAVING LOW TRAFFIC VOLUMES.

* FOR SIGN SPACING AND TAPER LENGTH REFER TO APPENDIX "D".



STREET NAME

INDICATE NORTH

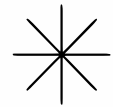

100 FT. PER LANE MAX.

RAISED MEDIAN

LEGEND

- CHANNELIZING DEVICE
- SIGN STAND
- ▒ WORK AREA
- ↑ DIRECTION OF TRAVEL
- ARROW PANEL

* FOR SIGN SPACING AND TAPER LENGTH REFER TO APPENDIX "D".

* PLACEMENT OF THE ARROW PANEL SHOULD BE ON THE SHOULDER AT THE START OF THE CLOSURE AND IN THE CLOSED LANE IF NO SHOULDER IS AVAILABLE.

STREET NAME

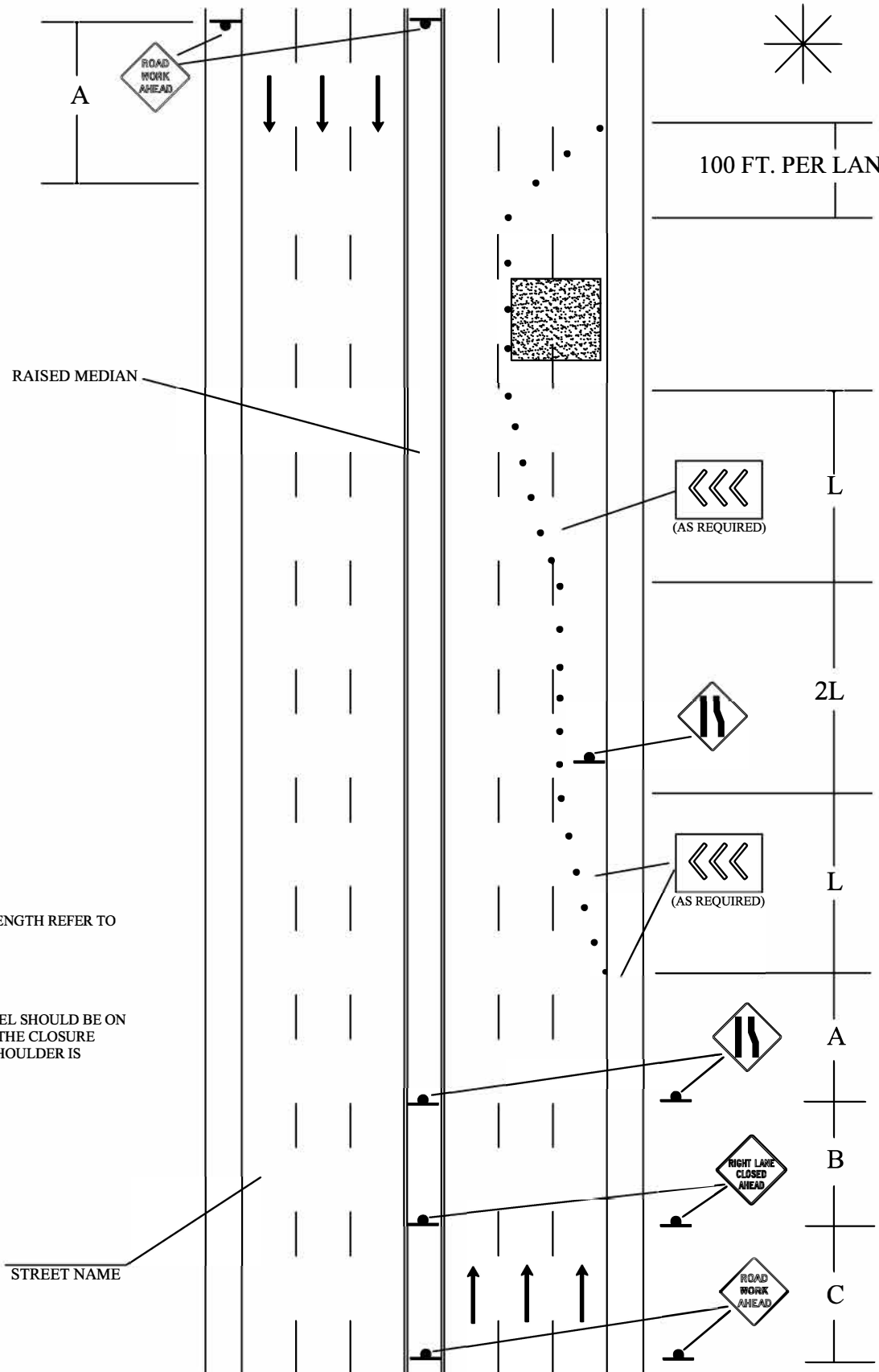

INDICATE NORTH

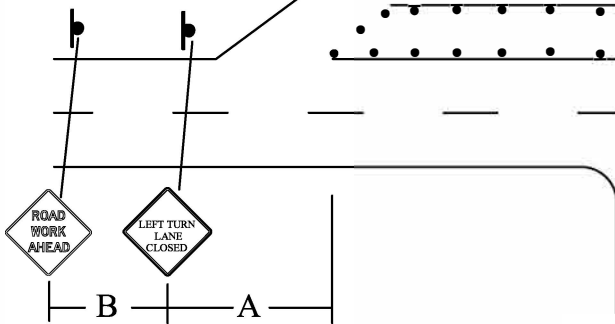
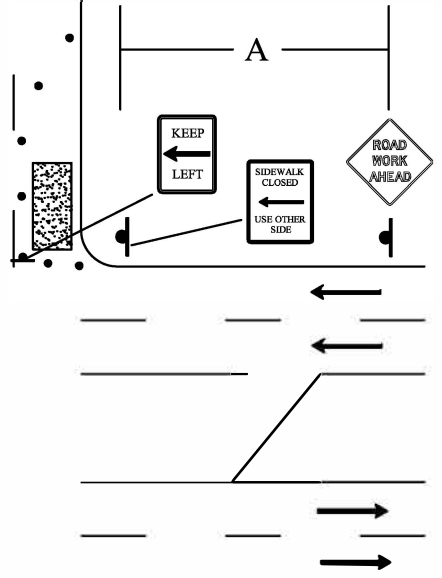
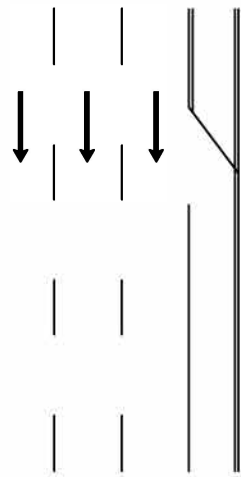
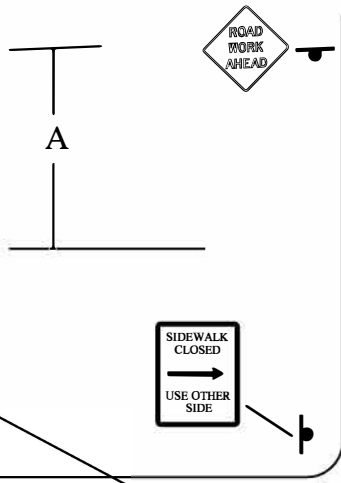
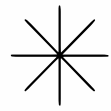

LEGEND

- CHANNELIZING DEVICE
- SIGN STAND
- WORK AREA
- DIRECTION OF TRAVEL
- ARROW PANEL

STREET NAME

RAISED MEDIAN

* FOR SIGN SPACING AND TAPER LENGTH REFER TO APPENDIX "D".

* PLACEMENT OF THE ARROW PANEL SHOULD BE ON THE SHOULDER AT THE START OF THE CLOSURE AND IN THE CLOSED LANE IF NO SHOULDER IS AVAILABLE.

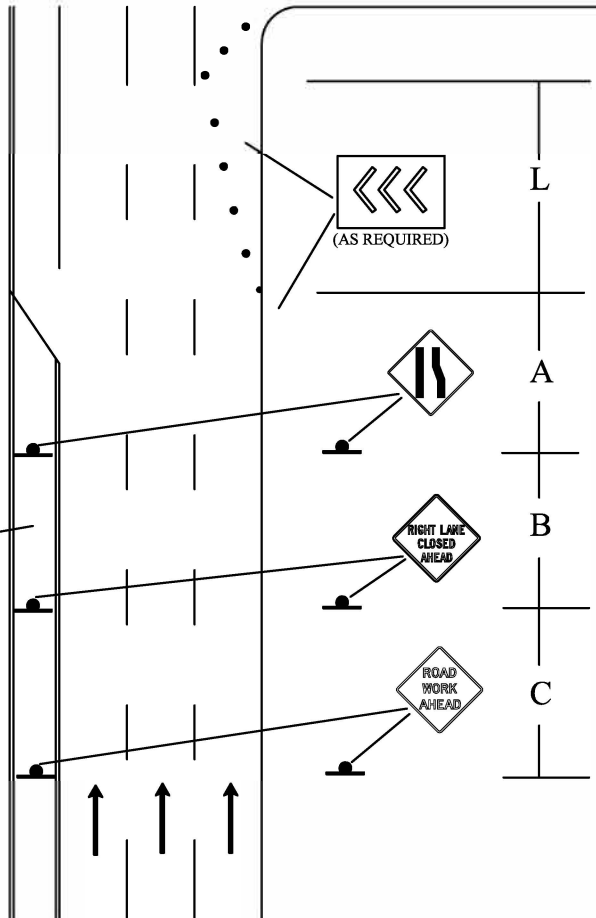

INDICATE NORTH

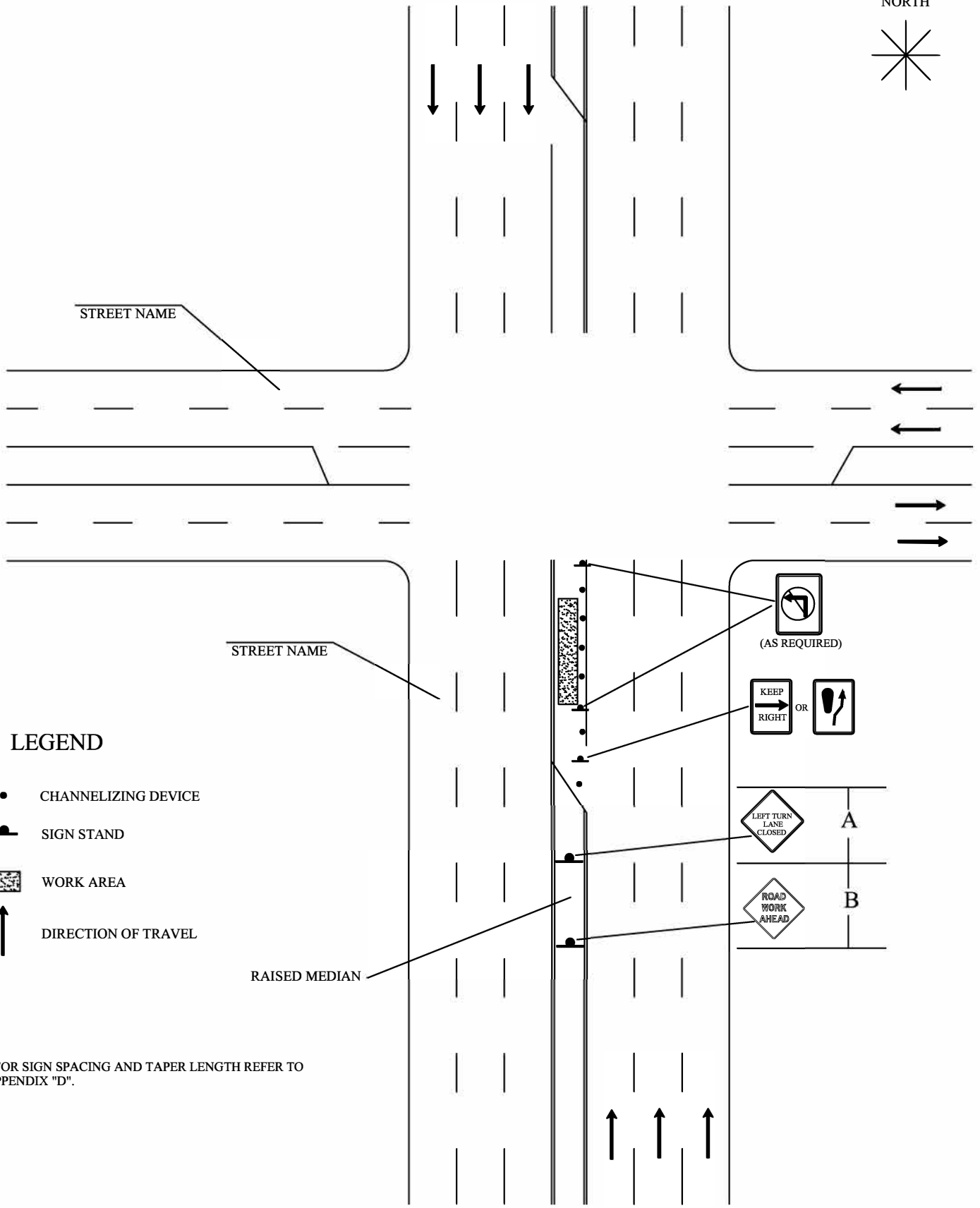
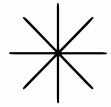

STREET NAME

STREET NAME

LEGEND

- CHANNELIZING DEVICE
- ▬ SIGN STAND
- ▨ WORK AREA
- ↑ DIRECTION OF TRAVEL

RAISED MEDIAN



(AS REQUIRED)



A



B

* FOR SIGN SPACING AND TAPER LENGTH REFER TO APPENDIX "D".

INDICATE NORTH

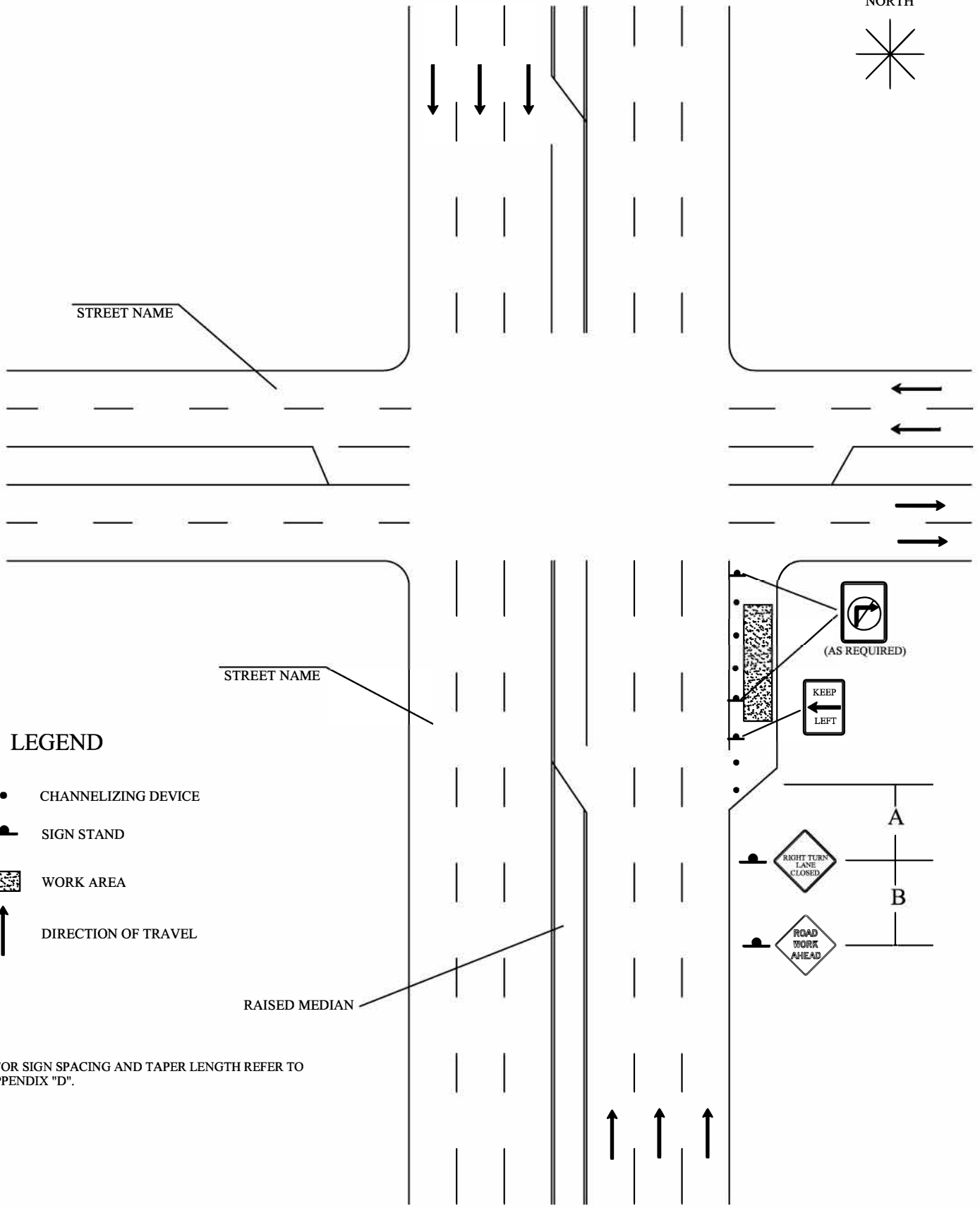
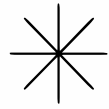

LEGEND

- CHANNELIZING DEVICE
- ▬ SIGN STAND
- ▨ WORK AREA
- ↑ DIRECTION OF TRAVEL

STREET NAME

RAISED MEDIAN

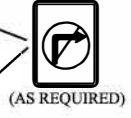

A

B

* FOR SIGN SPACING AND TAPER LENGTH REFER TO APPENDIX "D".

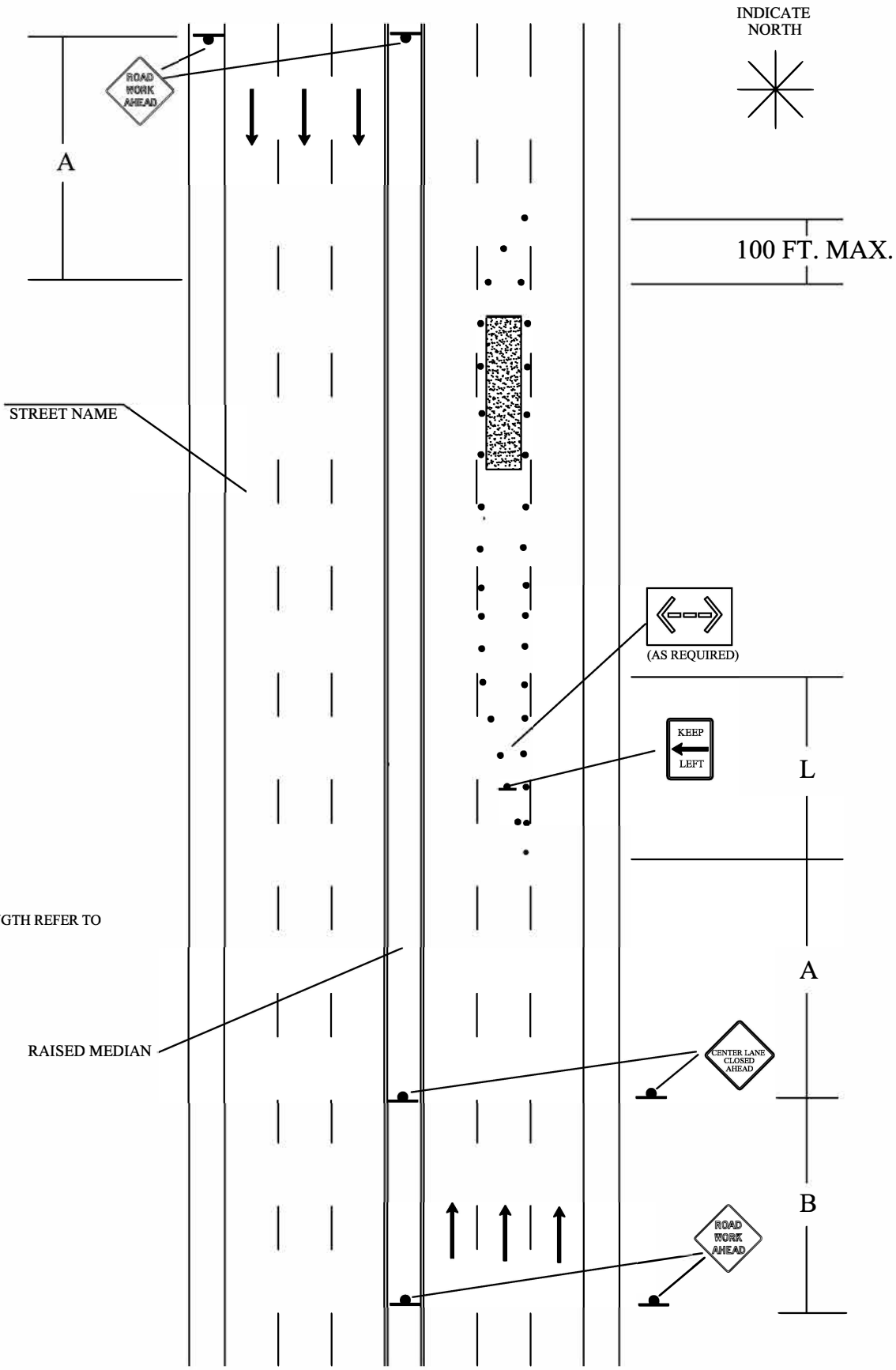

INDICATE NORTH

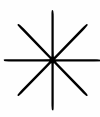

100 FT. MAX.

LEGEND

- CHANNELIZING DEVICE
- SIGN STAND
- ▨ WORK AREA
- ↑ DIRECTION OF TRAVEL
- ↔ ARROW PANEL

* FOR SIGN SPACING AND TAPER LENGTH REFER TO APPENDIX "D".

STREET NAME

RAISED MEDIAN

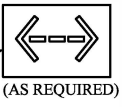

INDICATE NORTH

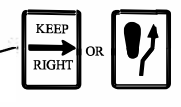
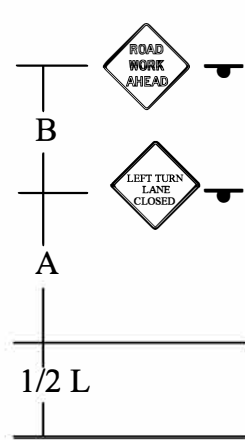
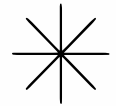

LEGEND

- CHANNELIZING DEVICE
- SIGN STAND
- ▨ WORK AREA
- ↑ DIRECTION OF TRAVEL

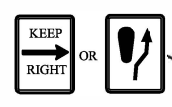
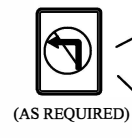

* FOR SIGN SPACING AND TAPER LENGTH REFER TO APPENDIX "D".

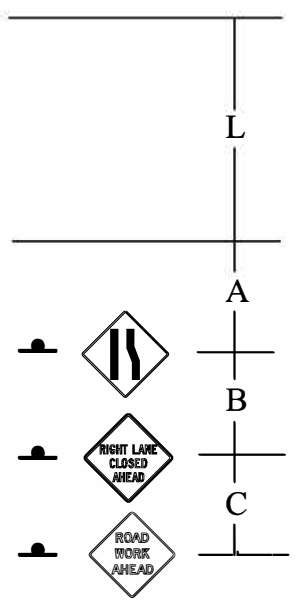
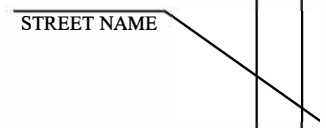

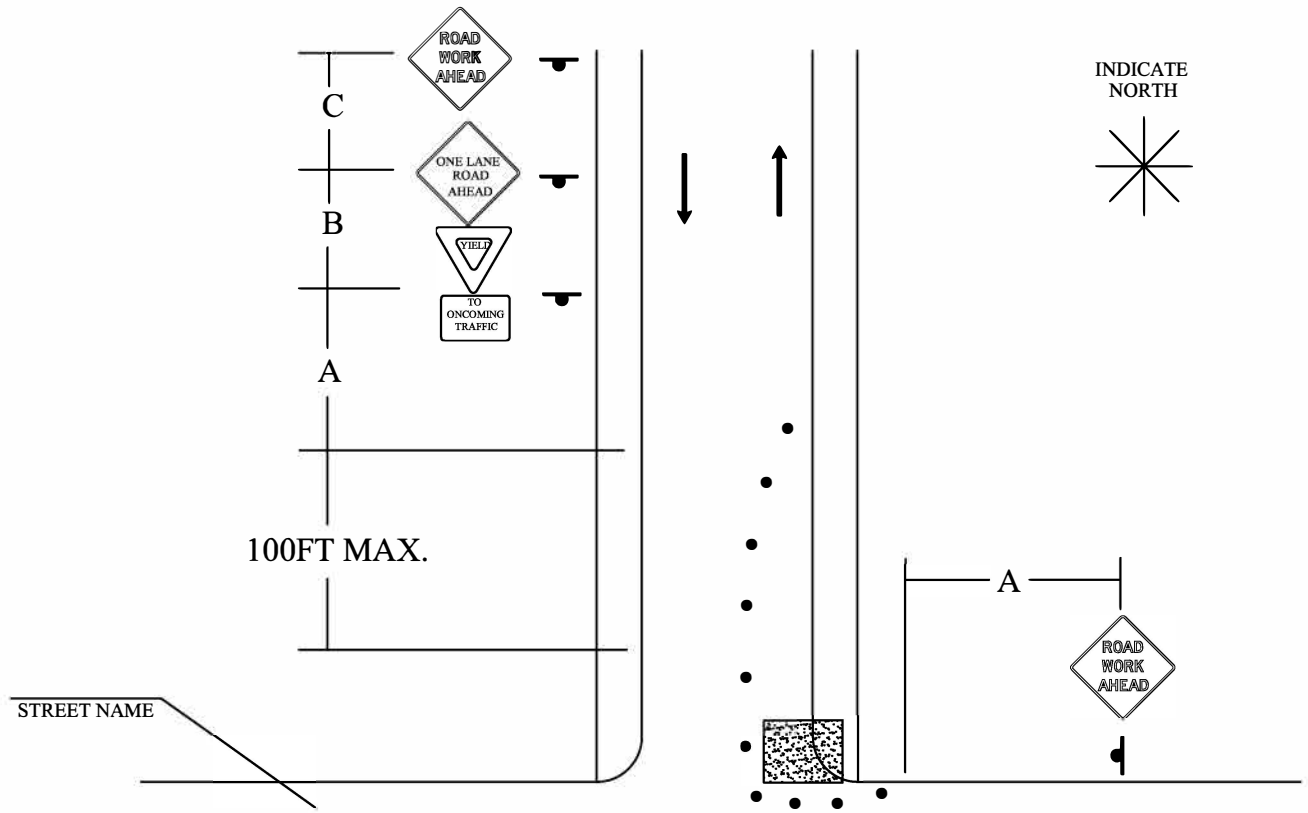

LEGEND

- CHANNELIZING DEVICE
- ▬ SIGN STAND
- ▨ WORK AREA
- ↑ DIRECTION OF TRAVEL

* THIS TRAFFIC PLAN SHALL BE USED ONLY FOR LOW-SPEED STREETS HAVING LOW TRAFFIC VOLUMES.

* FOR SIGN SPACING AND TAPER LENGTH REFER TO APPENDIX "D".

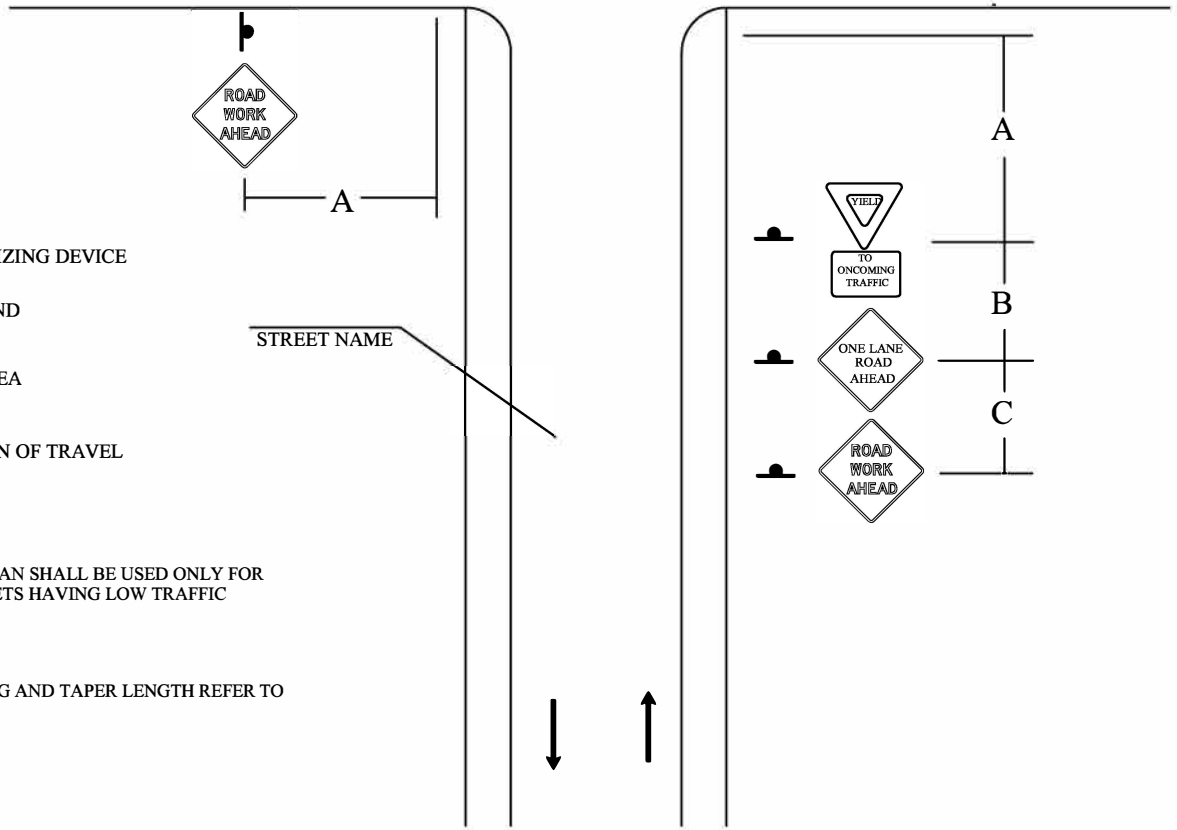

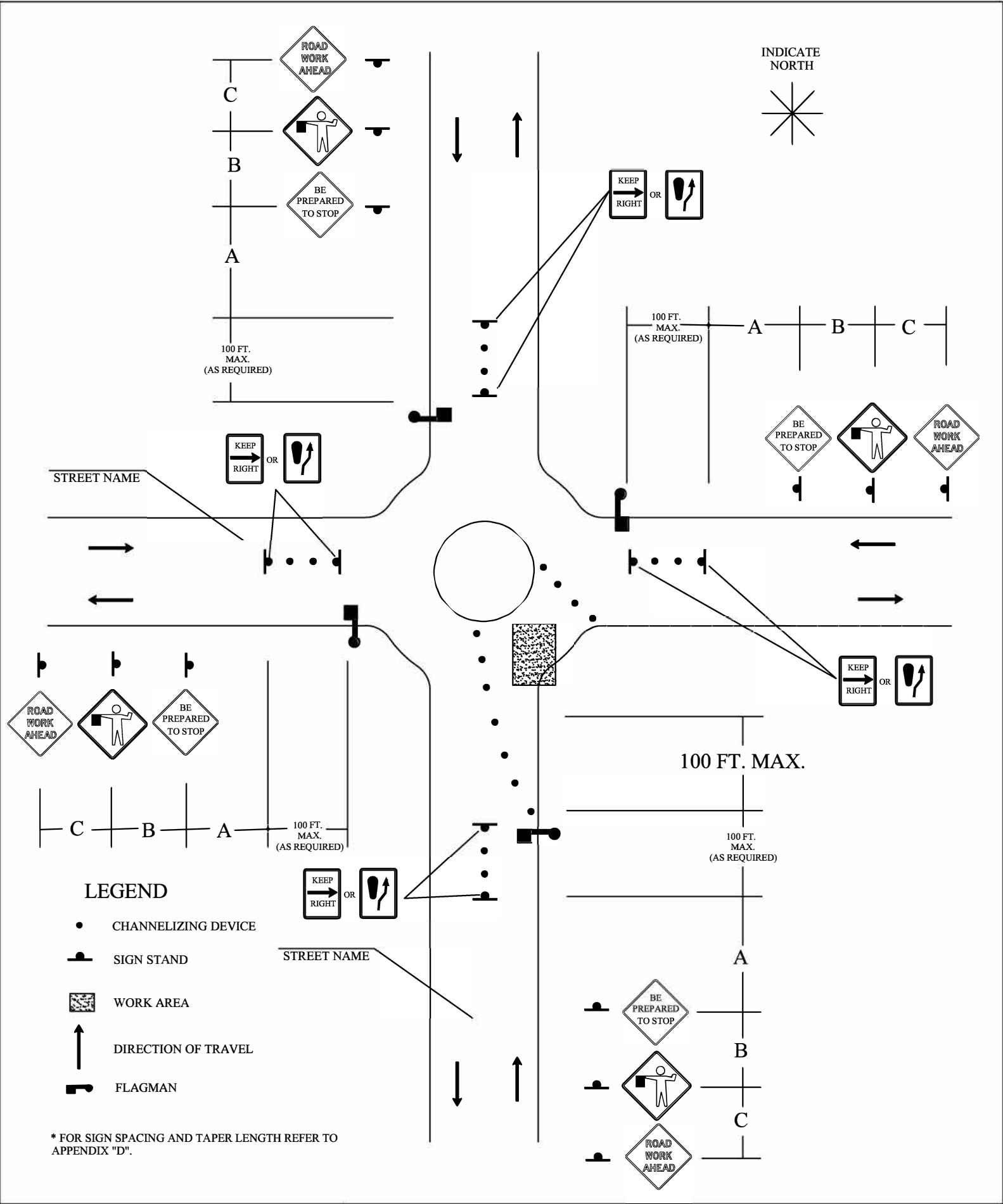

LEGEND

- CHANNELIZING DEVICE
- SIGN STAND
- ▨ WORK AREA
- ↑ DIRECTION OF TRAVEL
- FLAGMAN

* FOR SIGN SPACING AND TAPER LENGTH REFER TO APPENDIX "D".

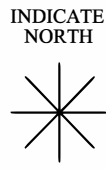
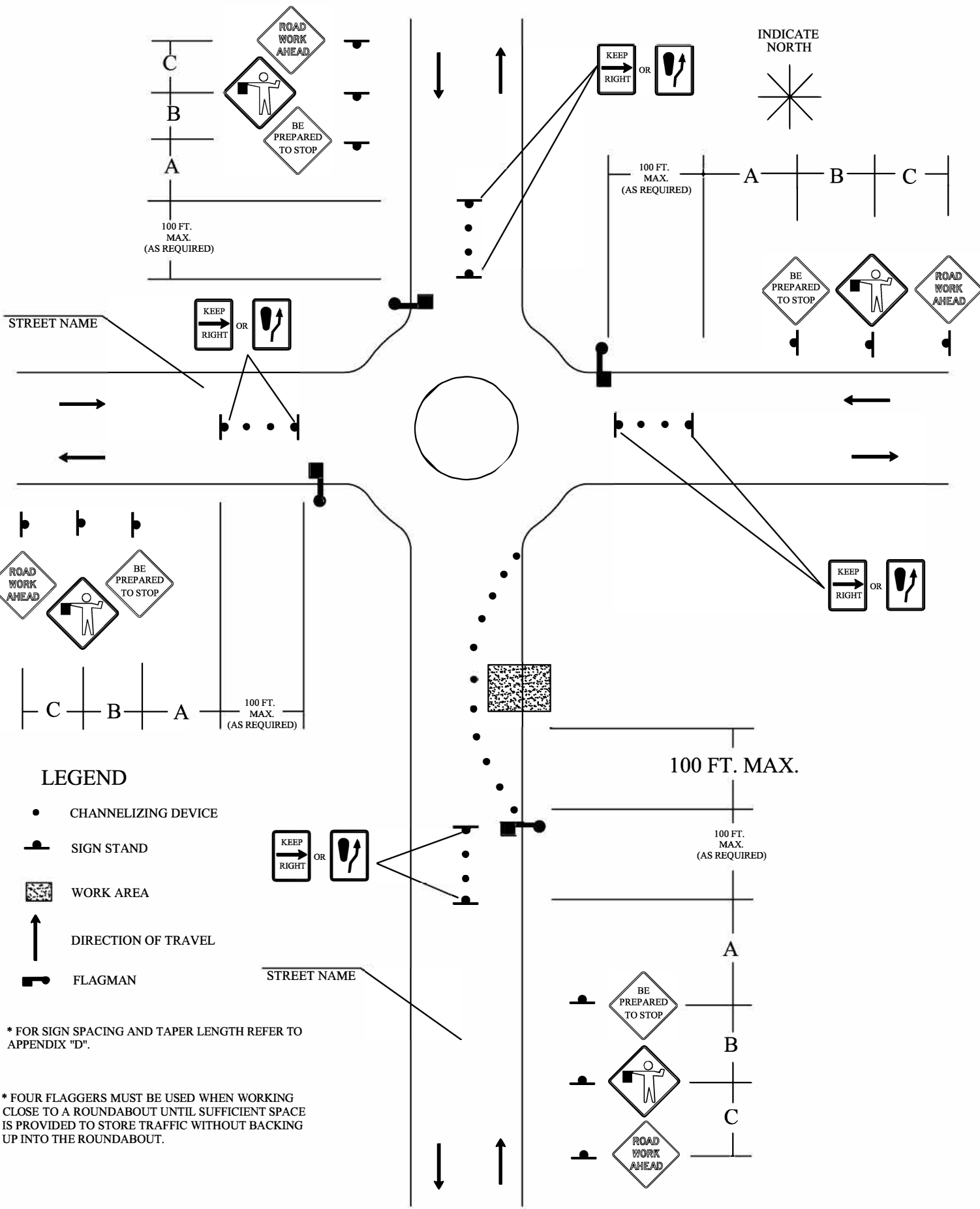

LEGEND

- CHANNELIZING DEVICE
- SIGN STAND
- WORK AREA
- DIRECTION OF TRAVEL
- FLAGMAN

* FOR SIGN SPACING AND TAPER LENGTH REFER TO APPENDIX "D".

* FOUR FLAGGERS MUST BE USED WHEN WORKING CLOSE TO A ROUNDABOUT UNTIL SUFFICIENT SPACE IS PROVIDED TO STORE TRAFFIC WITHOUT BACKING UP INTO THE ROUNDABOUT.

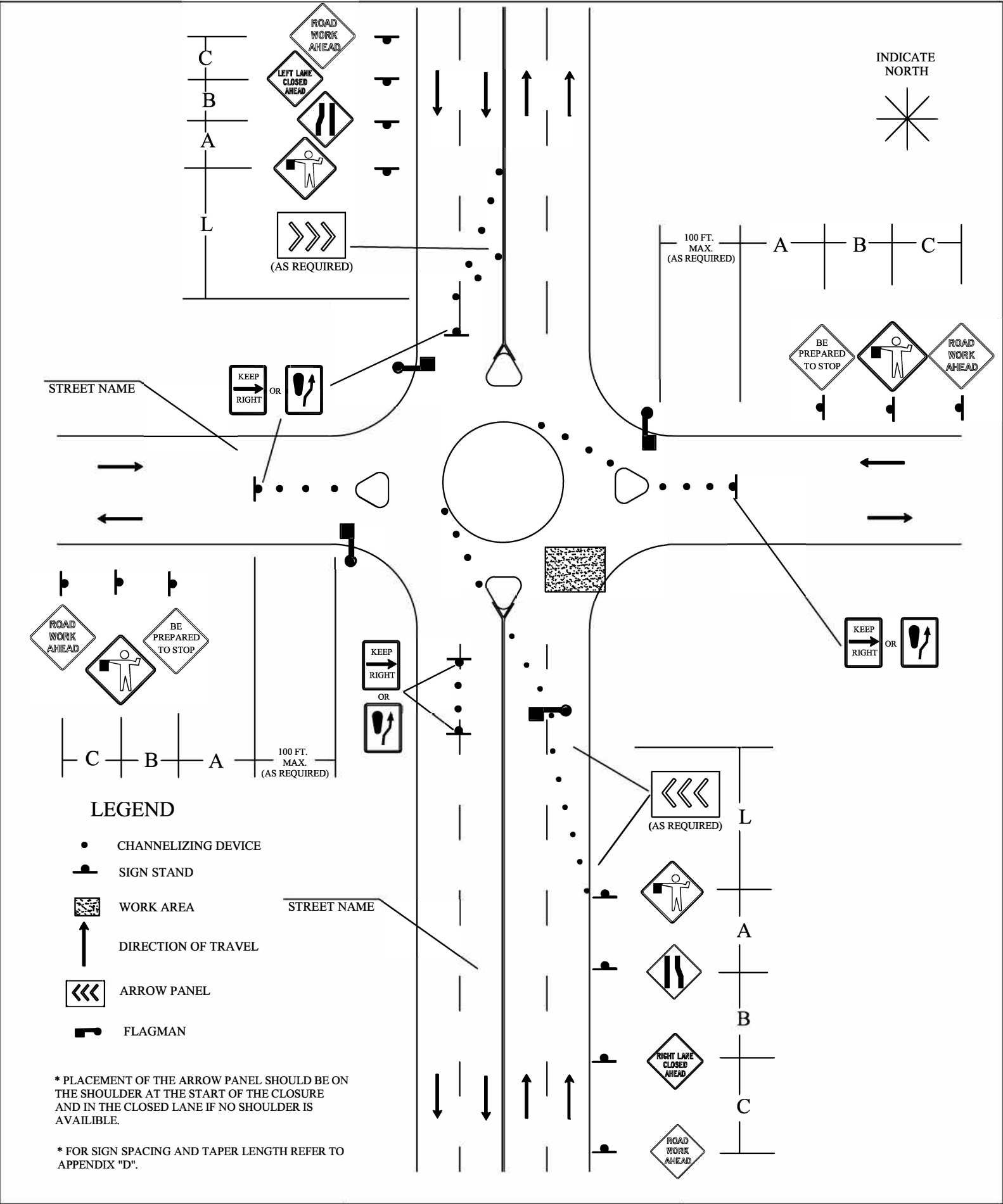

INDICATE NORTH

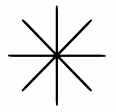

STREET NAME

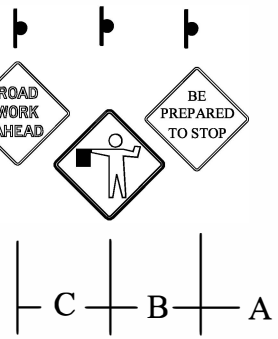
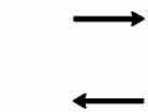

100 FT. MAX. (AS REQUIRED)

LEGEND

- CHANNELIZING DEVICE
- ▬ SIGN STAND
- ▨ WORK AREA
- ↑ DIRECTION OF TRAVEL
- ◀◀◀ ARROW PANEL
- ▬ FLAGMAN

* PLACEMENT OF THE ARROW PANEL SHOULD BE ON THE SHOULDER AT THE START OF THE CLOSURE AND IN THE CLOSED LANE IF NO SHOULDER IS AVAILABLE.

* FOR SIGN SPACING AND TAPER LENGTH REFER TO APPENDIX "D".

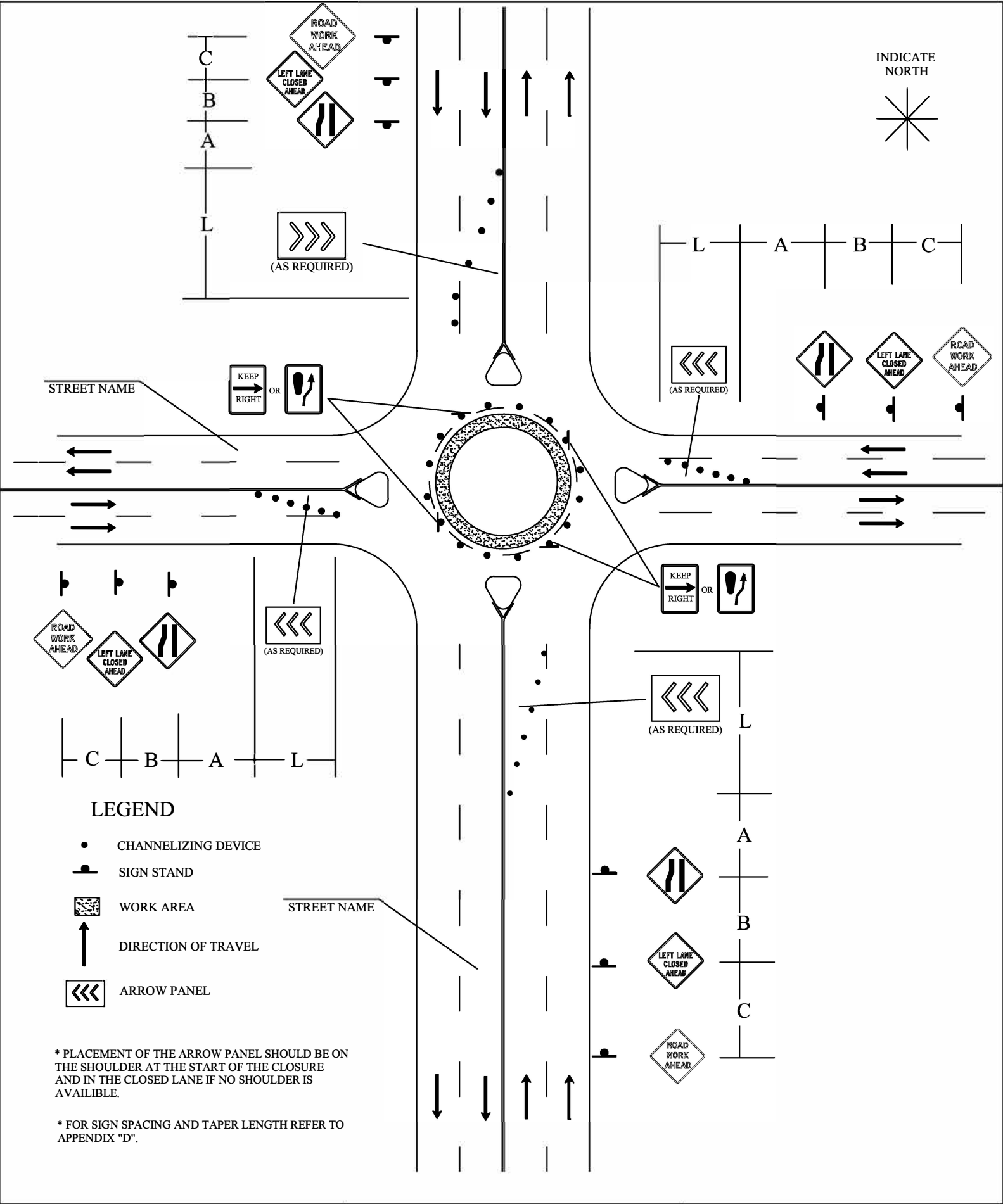

- LEGEND**
- CHANNELIZING DEVICE
 - SIGN STAND
 - WORK AREA
 - ↑ DIRECTION OF TRAVEL
 - ◀◀◀ ARROW PANEL

* PLACEMENT OF THE ARROW PANEL SHOULD BE ON THE SHOULDER AT THE START OF THE CLOSURE AND IN THE CLOSED LANE IF NO SHOULDER IS AVAILABLE.

* FOR SIGN SPACING AND TAPER LENGTH REFER TO APPENDIX "D".

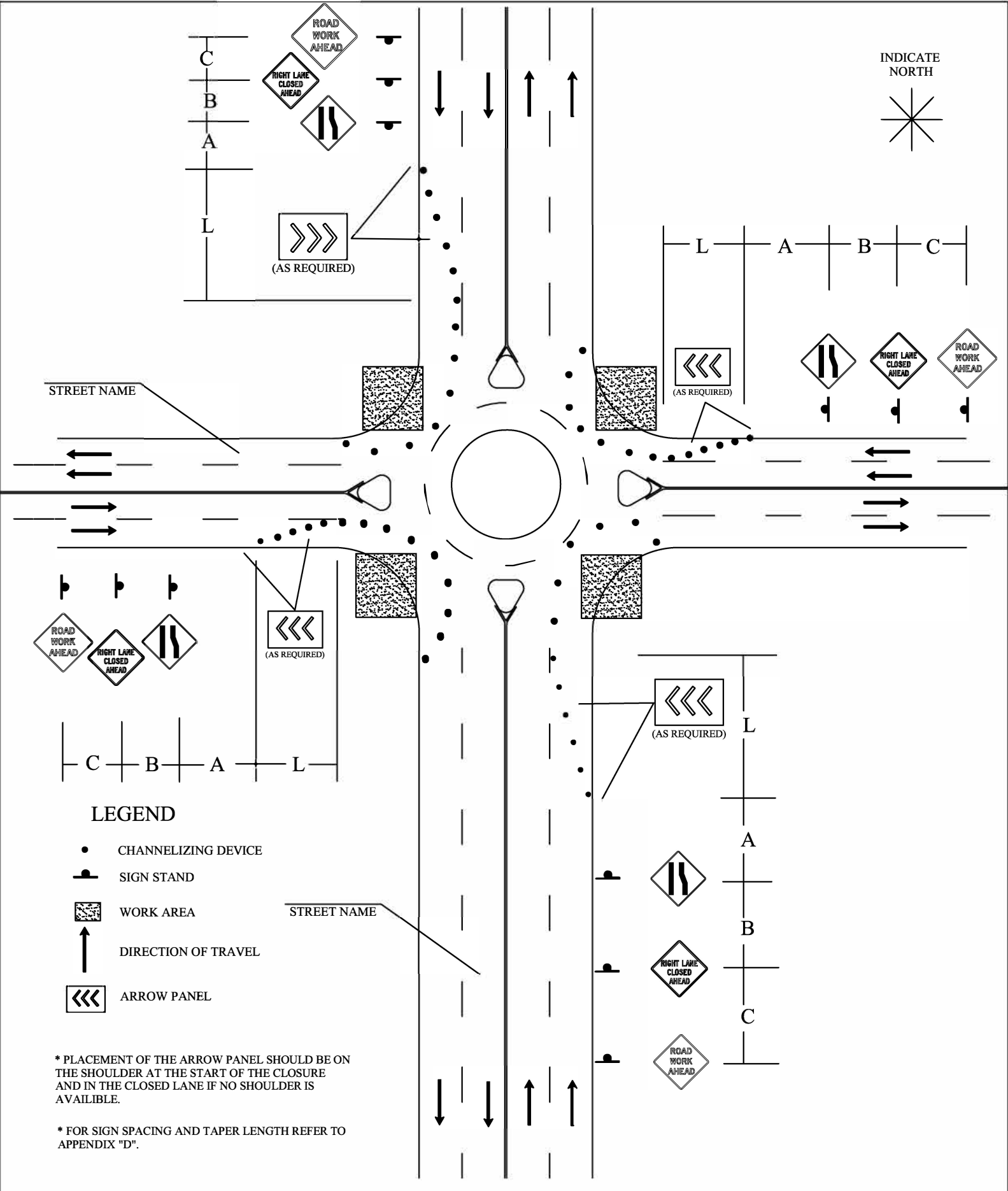

INDICATE NORTH

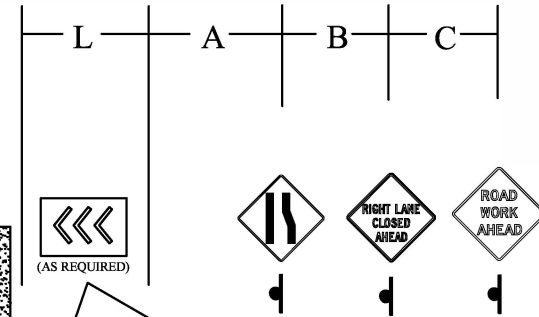
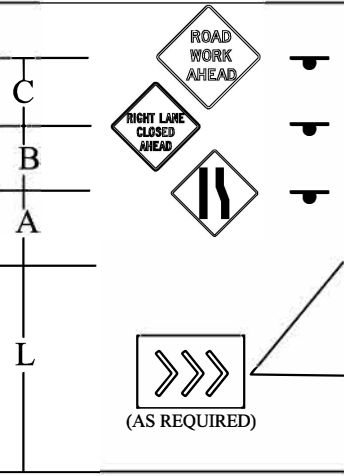
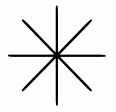

STREET NAME

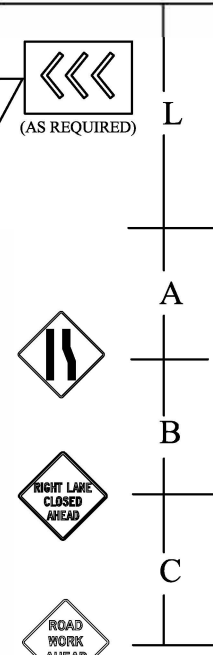
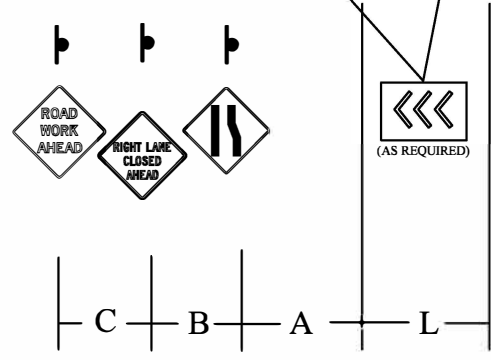
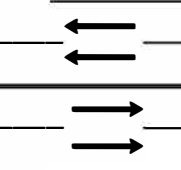

LEGEND

- CHANNELIZING DEVICE
- SIGN STAND
- ▨ WORK AREA
- ↑ DIRECTION OF TRAVEL
- ◀◀◀ ARROW PANEL

* PLACEMENT OF THE ARROW PANEL SHOULD BE ON THE SHOULDER AT THE START OF THE CLOSURE AND IN THE CLOSED LANE IF NO SHOULDER IS AVAILABLE.

* FOR SIGN SPACING AND TAPER LENGTH REFER TO APPENDIX "D".

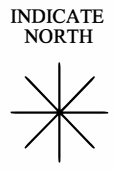
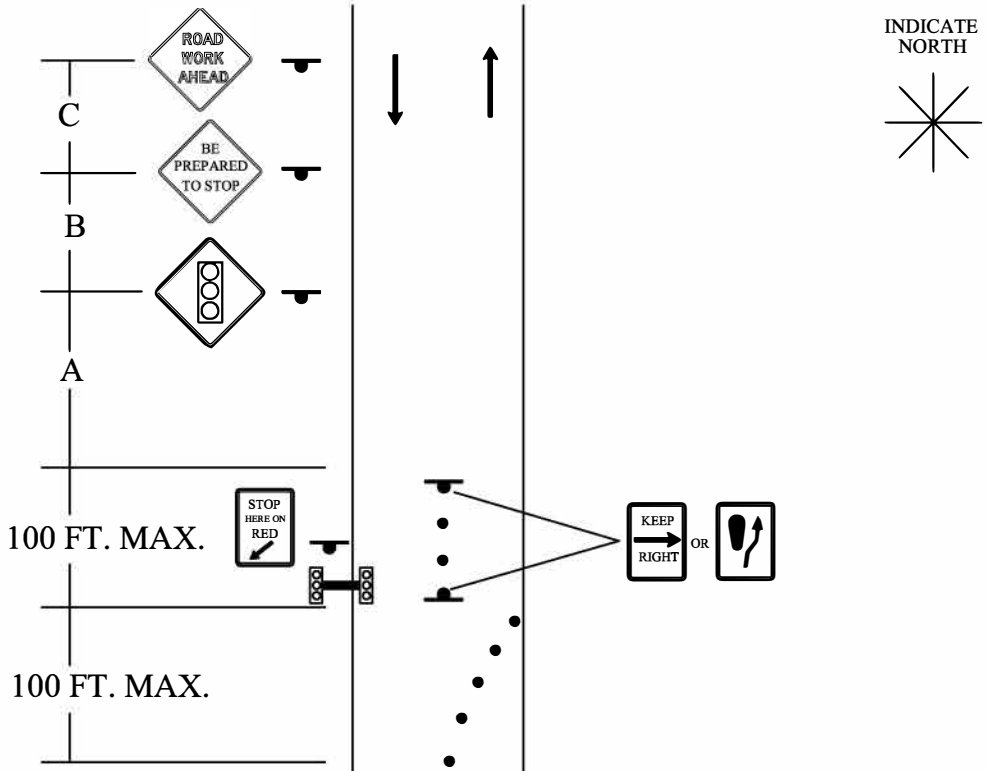

LEGEND

- CHANNELIZING DEVICE
- SIGN STAND
- ▨ WORK AREA
- ↑ DIRECTION OF TRAVEL
- ⊞ TEMP. SIGNALS

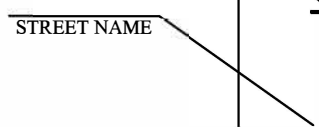
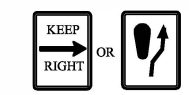

* FOR SIGN SPACING AND TAPER LENGTH REFER TO APPENDIX "D".

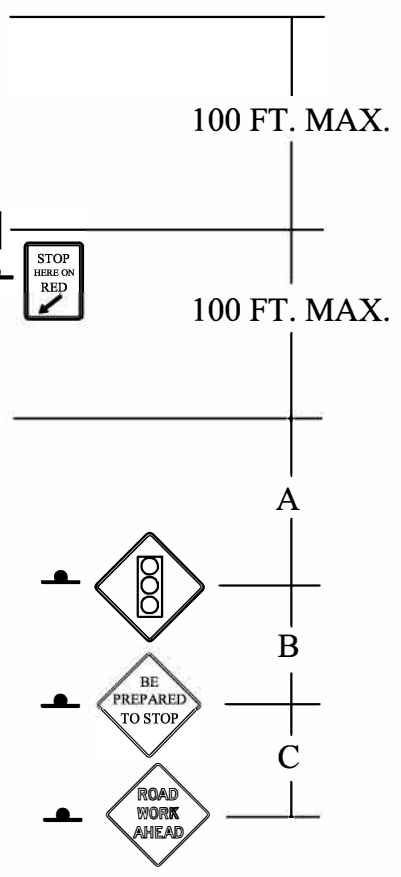



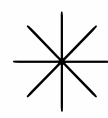



INDICATE NORTH



STREET NAME

LEGEND

-  CHANNELIZING DEVICE
-  SIGN STAND
-  WORK AREA
-  DIRECTION OF TRAVEL
-  ARROW PANEL
-  WORK VEHICLE

* PLACEMENT OF THE ARROW PANEL SHOULD BE ON THE SHOULDER AT THE START OF THE CLOSURE AND IN THE CLOSED LANE IF NO SHOULDER IS AVAILABLE.

* FOR SIGN SPACING AND TAPER LENGTH REFER TO APPENDIX "D".

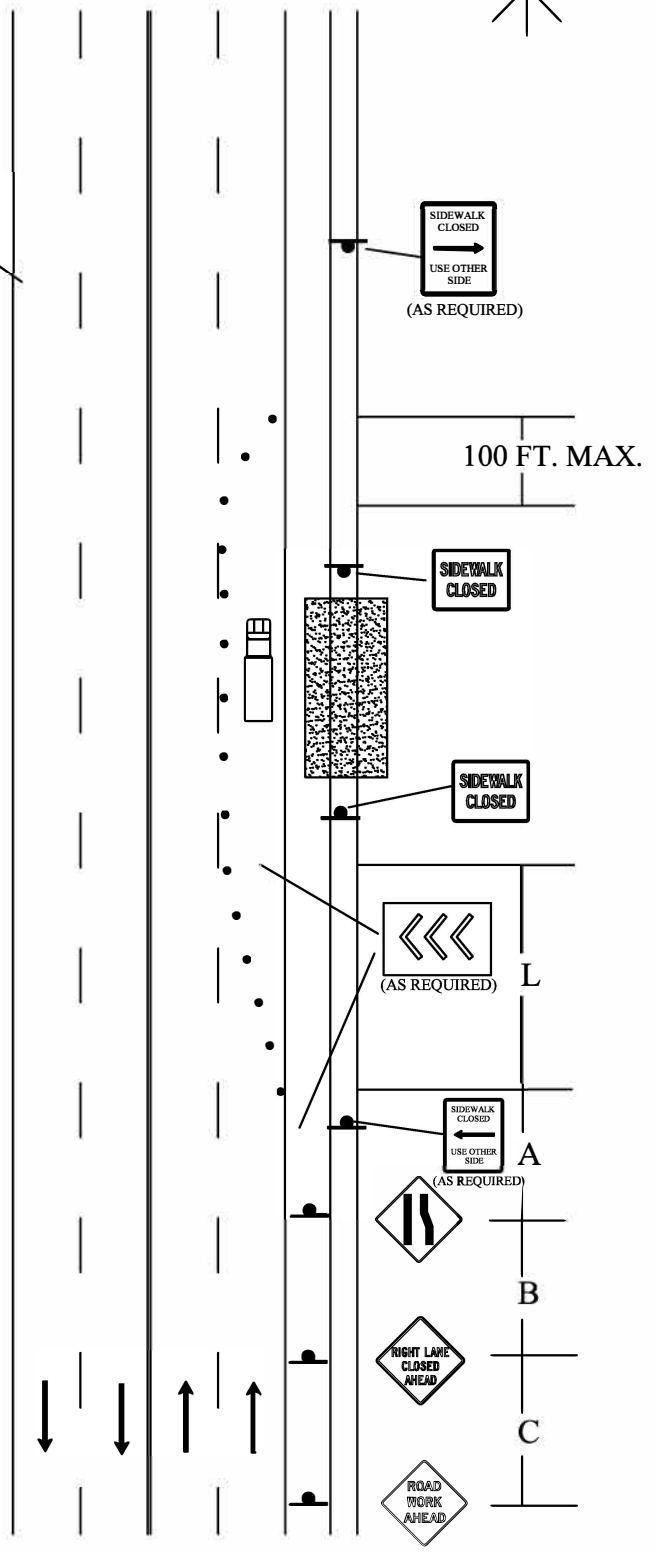

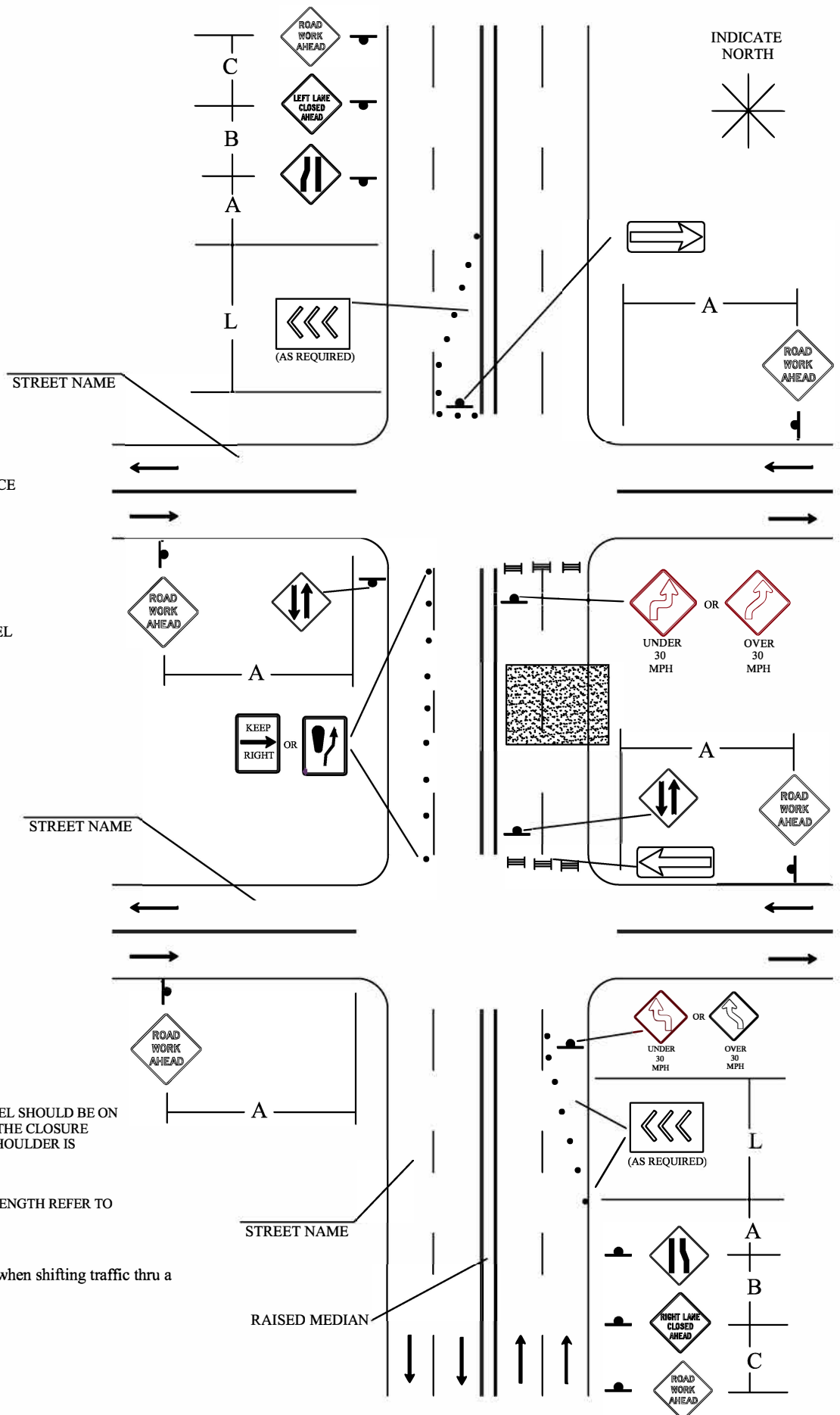

LEGEND

- CHANNELIZING DEVICE
- ▬ SIGN STAND
- ▨ WORK AREA
- ↑ DIRECTION OF TRAVEL
- ◀◀◀ ARROW PANEL
- ▬▬▬ TYPE III BARRICADE

* PLACEMENT OF THE ARROW PANEL SHOULD BE ON THE SHOULDER AT THE START OF THE CLOSURE AND IN THE CLOSED LANE IF NO SHOULDER IS AVAILABLE.



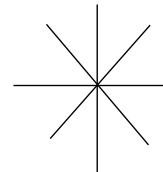

* FOR SIGN SPACING AND TAPER LENGTH REFER TO APPENDIX "D".

* Uniformed police shall be used when shifting traffic thru a signalized intersection.

INDICATE NORTH



LEGEND

-  CHANNELIZING DEVICE
-  TYPE I OR II BARRICADE
-  SIGN STAND
-  WORK AREA
-  DIRECTION OF TRAVEL



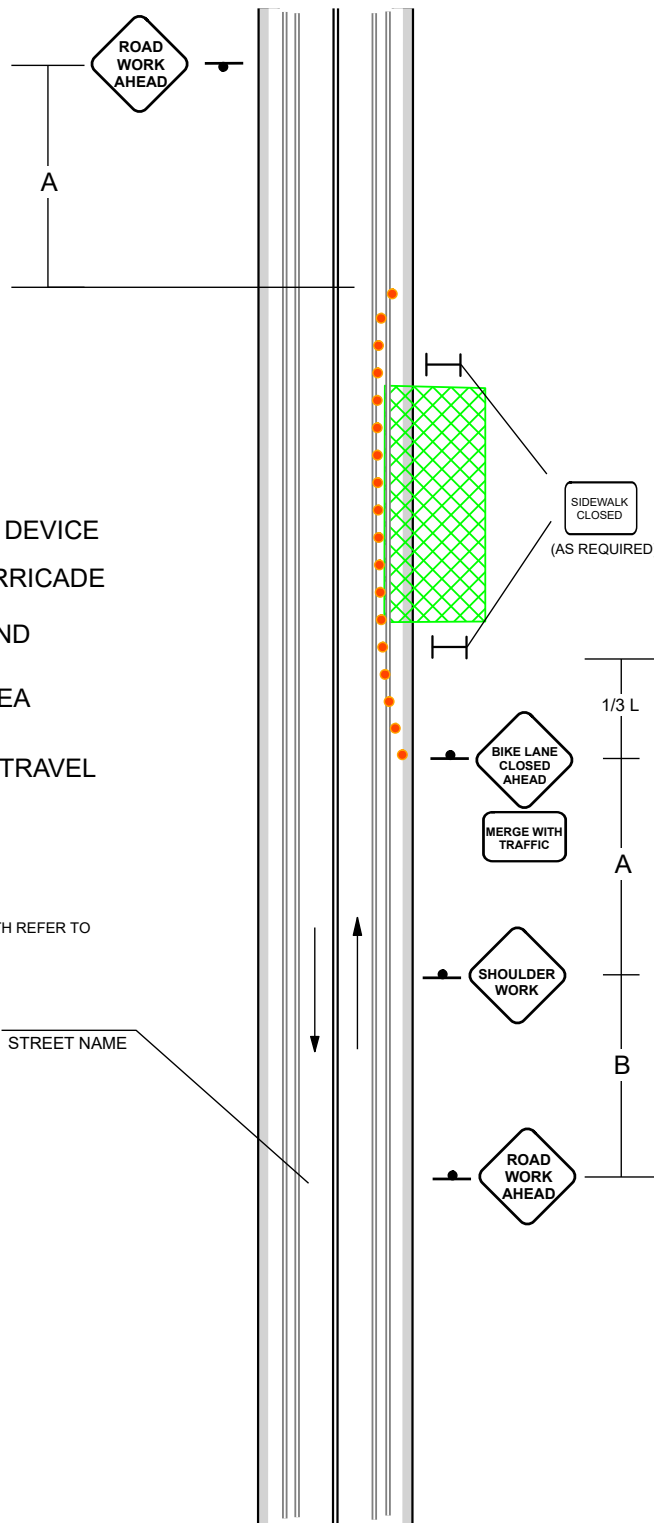

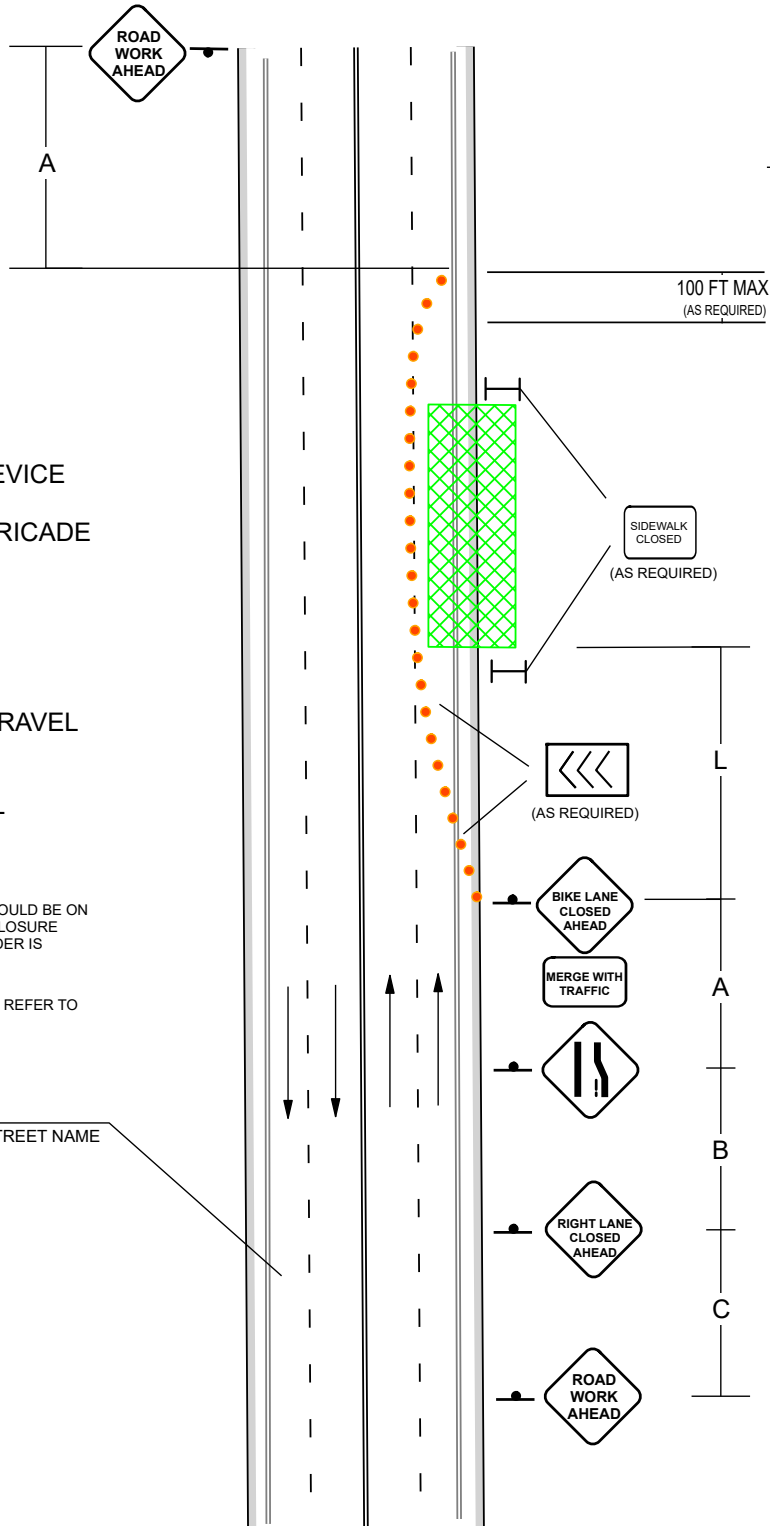
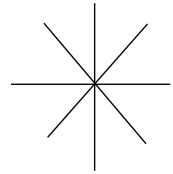

* FOR SIGN SPACING AND TAPER LENGTH REFER TO APPENDEX C



INDICATE NORTH



LEGEND

-  CHANNELIZING DEVICE
-  TYPE I OR II BARRICADE
-  SIGN STAND
-  WORK AREA
-  DIRECTION OF TRAVEL
-  ARROW PANEL

* PLACEMENT OF THE ARROW PANEL SHOULD BE ON THE SHOULDER AT THE START OF THE CLOSURE AND IN THE CLOSED LANE IF NO SHOULDER IS AVAILABLE.

* FOR SIGN SPACING AND TAPER LENGTH REFER TO APPENDE X C

STREET NAME