

Site Accessibility Evaluation

Americans with Disabilities Act Title II (Public Services: State and Local Government)



Sinton Pond Open Space

**3645 Sinton Rd
Northeast Colorado
Springs, CO 80907**

Accessibility Evaluation

***Inspection Date: 11/20/2020
Inspector: Michael Killebrew***

Prepared By



OLYMPIC CITY USA

(719) 385 - 5175

<https://coloradosprings.gov/>

TO: Parks, Recreation and Cultural Services

FROM: Robert L. Hernandez

DATE: January 19, 2021

SUBJECT: Sinton Pond Open Space Self-Evaluation

1. On November 20, 2020, Mr. Michael Killebrew, Title II ADA/Section 504 Coordinator performed a Title II - Americans with Disabilities Act (ADA), Self-Evaluation. This evaluation was in accordance with the 1991/2010 ADA Standards for Accessible Design.

2. Priorities for accessibility are assigned in accordance with the ADA Checklist for Existing Facilities. The checklist follows the four priorities listed in the Department of Justice ADA Title III regulations. These priorities are equally applicable to state and local government facilities:

Priority 1 - Accessible approach and entrance

Priority 2 - Access to goods and services

Priority 3 - Access to public toilet rooms

Priority 4 - Access to other items such as water fountains and public telephones

3. Corrective actions to findings were/will be submitted for corrective action through the city maintenance work request system and Transition Plan. Note: Recommended corrections in some cases where needed will be modified when appropriate. Corrections are developed in consideration of the "Program Access" provisions of Title II, where applicable.

4. A copy of this report will be maintained in the Office of Accessibility.

City of Colorado Springs Title II ADA/Section 504 – Manager
30 S. Nevada Ave, Suite 301
Colorado Springs, CO 80903
robert.hernandez@coloradosprings.gov

Atch 1. City of Colorado Springs, ADA Self-Evaluation Report

Sincerely,

A handwritten signature in blue ink that reads "Robert Hernandez". The signature is written in a cursive style.

Robert Hernandez

Sinton Pond Open Space

Lat: 38.8837059000, Long: -104.8324050000

Finding: 1

There is no accessible route to the pond for fishing or bird watching.

At least one accessible route shall connect accessible buildings, accessible facilities, accessible elements, and accessible spaces that are on the same site.

2015 IBC Section 1104.2

At least one accessible route shall connect accessible buildings, accessible facilities, accessible elements and accessible spaces that are on the same site.

2010 ADAS Section 206.2.2

At least one accessible route shall connect accessible buildings, accessible facilities, accessible elements, and accessible spaces that are on the same site.

Citation:

2015 IBC Section: 1104.2

2010 ADAS Section: 206.2.2

As Built:

There is no accessible route to the pond for fishing or on the other route for bird watching. Fishing and bird watching is a common activity for others here.

Recommendation:

Consider making an additional route for fishing and bird watching.

Barrier Priority:

2 (Important): Should be completed as soon as possible. (Includes findings that would remove barriers to the greatest number of people to your goods and services)

Department:

Parks & Recreation

Notes:

This isn't necessarily required. Also, we have Pikeview Reservoir close to here. This may not be feasible and we would need to probably do a full pier which isn't necessarily warranted. Also, the Sinton Trail goes close to the pond on one side.

Finding #1 Continued

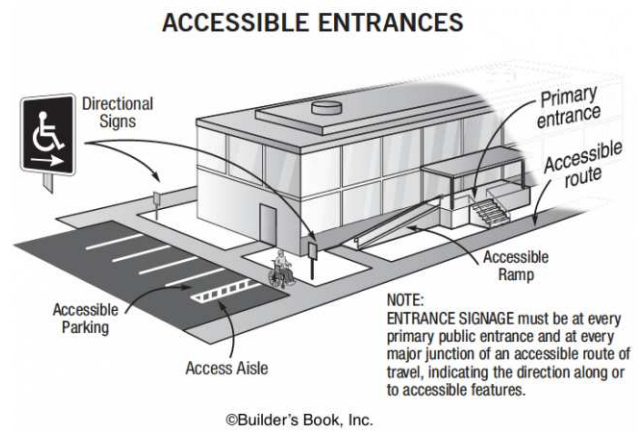

Sinton Pond Open Space

Lat: 38.8837059000, Long: -104.8324050000

Finding: 2

The surface of the curb ramp landing is not firm, stable and/or slip resistant..

Floor and ground surfaces shall be stable, firm, and slip resistant.

2010 ADAS Section 302.1

Floor and ground surfaces shall be stable, firm, and slip resistant and shall comply with 302.

Citation:

2010 ADAS Section: 302.1

As Built:

The curb ramp for the trail lacks a level landing. There is a landing but it isn't firm, stable or slip resistant.

Recommendation:

Add a level landing and explore making this route accessible all the way to the connecting trail.

Barrier Priority:

1 (High): Should be completed immediately. (Includes findings that have little or no cost, were in violation of the codes at the time of construction, or pose an imminent safety threat)

Department:

Parks & Recreation

Notes:

N/A

Finding #2 Continued

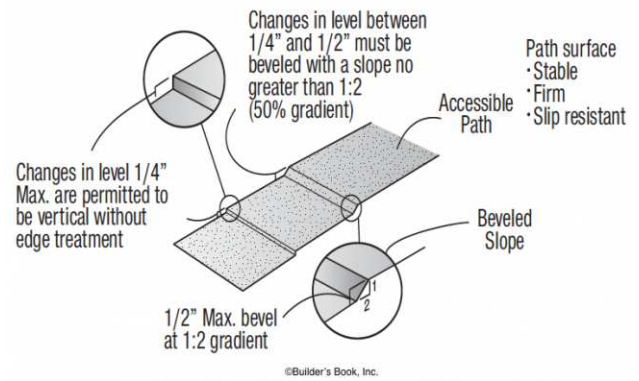

Sinton Pond Open Space

Lat: 38.8837059000, Long: -104.8324050000

Finding: 3

There are no close accessible parking stalls. The write up for this parking lot is in the Goose Gossage Sports Park write up.

Each lot where parking is provided for the public as clients, guests or employees, shall provide accessible parking and shall be located on the shortest accessible route of travel from adjacent parking to an accessible entrance.

2015 IBC Section 1106.1

Where parking is provided, accessible parking spaces shall be provided in compliance with Table 1106.1, except as required by Sections 1106.2 through 1106.4. Where more than one parking facility is provided on a site, the number of parking spaces required to be accessible shall be calculated separately for each parking facility.

2010 ADAS Section 208.2

Parking spaces complying with 502 shall be provided in accordance with Table 208.2 except as required by 208.2.1, 208.2.2, and 208.2.3. Where more than one parking facility is provided on a site, the number of accessible spaces provided on the site shall be calculated according to the number of spaces required for each parking facility.

Citation:

2015 IBC Section: 1106.1

2010 ADAS Section: 208.2

As Built:

The parking area for this is closed November - May and it is approximately 1,250 feet distance to the closest parking space.

Recommendation:

Probably nothing at this time. This is too far away to be considered an accessible option.

Barrier Priority:

1 (High): Should be completed immediately. (Includes findings that have little or no cost, were in violation of the codes at the time of construction, or pose an imminent safety threat)

Department:

Parks & Recreation

Notes:

N/A

Finding #3 Continued



Total Number of Parking Spaces Provided in Parking Facility	Minimum Number of Required Accessible Parking Spaces
1 to 25	1
26 to 50	2
51 to 75	3
76 to 100	4
101 to 150	5
151 to 200	6
201 to 300	7
301 to 400	8
401 to 500	9
501 to 1000	2 percent of total
1001 and over	20, plus 1 for each 100, or fraction thereof, over 1000

Sinton Pond Open Space

Lat: 38.8837059000, Long: -104.8324050000

Finding: 4

There are no on-street accessible parking stalls.

Technically accessible on street parking isn't required here since nothing is marked or metered.

2011 PROWAG Section R214

Where on-street parking is provided on the block perimeter and the parking is marked or metered, accessible parking spaces complying with R309 (On-Street Parking Spaces) shall be provided in accordance with Table R214 (Scoping - On-Street Parking Spaces).

Citation:

2011 PROWAG Section: R214

As Built:

The other parking area for this park is on Sinton Road. There is no accessible parking or route to the open space from this direction.

Recommendation:

Do nothing at this time. If and when this space developed more we should explore parking options.

Barrier Priority:

1 (High): Should be completed immediately. (Includes findings that have little or no cost, were in violation of the codes at the time of construction, or pose an imminent safety threat)

Department:

Parks & Recreation

Notes:

N/A

Finding #4 Continued



Table R214 On-Street Parking Spaces

Total Number of Marked or Metered Parking Spaces on the Block Perimeter	Minimum Required Number of Accessible Parking Spaces
1 to 25	1
26 to 50	2
51 to 75	3
76 to 100	4
101 to 150	5
151 to 200	6
201 and over	4 percent of total

Finding #4 Additional Finding Photos



Finding 190271 Additional Photo