



# **REQUEST FOR PROPOSAL**

**Construction**

**R24-115MZ**

Date issued: September 17, 2024

# **MEMORIAL PARK WAR MEMORIAL CONSTRUCTION**

**THE CITY OF COLORADO SPRINGS**

**THIS PROJECT IS FUNDED BY A GRANT FROM THE  
AMERICAN RESCUE PLAN ACT (ARPA)**



**The City of Colorado Springs requests Firm Fixed Price (FFP) (or Fixed Unit Price) proposals, as detailed in this Request for Proposal (RFP), for Memorial Park War Memorial Construction**

This RFP is posted to Rocky Mountain E-Purchasing BidNet Direct and the City of Colorado Springs' Procurement Services Website. It is available for all vendors free of charge, following free registration, at the Rocky Mountain E-Purchasing BidNet Direct website.

**SUBMITTALS FOR THIS PROJECT WILL ONLY BE ACCEPTED ON THE ROCKY MOUNTAIN E-PURCHASING BIDNET DIRECT PLATFORM.**

Please login to the following website to register (Free Registration) to submit a bid for this project. All required documents will be uploaded to the website.

<https://www.bidnetdirect.com/>

**BIDNET Support**

**800-835-4603**

**Estimated Project Magnitude: \$350,000.00 - \$450,000.00**



## **SECTION INDEX**

SECTION I PROPOSAL INFORMATION

SECTION II PROPOSAL CONTENT

SECTION III EVALUATION FACTORS

SECTION IV SPECIAL CONTRACT TERMS AND CONDITIONS/SPECIAL SOLICITATION  
PROVISIONS

SECTION V EXHIBITS

SECTION VI SCHEDULES



## SECTION I – PROPOSAL INFORMATION

### 1.0 PROPOSAL INFORMATION

Section I provides general information to potential Offerors, such as proposal submission instructions and other similar administrative elements. This RFP is available on BidNet Direct under the Rocky Mountain E-Purchasing Group ([www.BidNetDirect.com](http://www.BidNetDirect.com)). All addenda or amendments shall be issued through BidNet Direct and may not be available through any other source.

### 1.1 RFP SCHEDULE OF EVENTS

The upcoming schedule of events is as follows:

<b><u>Event</u></b>	<b><u>Date</u></b>
Issue Request for Proposal	September 17, 2024
Pre-Proposal Conference	October 2, 2024 1:00PM

We will hold a pre-proposal conference at Memorial Park War Memorial, 1605 E. Pikes Peak Ave Colorado Springs, CO 80910. This meeting is not mandatory. However all Offerors are encouraged to attend.

Cut Off Date for Questions	October 4, 2024 1:00PM
----------------------------	------------------------

All questions shall be submitted electronically via email to the following Contract Specialist. All questions must be received no later than **1:00PM October 4, 2024.**

Requests for Information, support and questions shall be directed to:

CONTRACT SPECIALIST Mike Zeller  
CONTRACT SPECIALIST [michael.zeller@coloradosprings.gov](mailto:michael.zeller@coloradosprings.gov)

DO NOT CONTACT ANY OTHER INDIVIDUAL AT THE CITY OF COLORADO SPRINGS REGARDING THIS SOLICITATION.
--

**The only acceptable method of submitting questions is electronically via BidNet Direct. Faxes or physical mail delivery are not acceptable.**

Proposal Due Date	October 15, 2024 2:00PM
Interviews (if applicable)	TBD
Award of Contract	EST October 30, 2024
Notice to Proceed	EST November 15, 2024



## 1.2 SUBMISSION OF PROPOSAL

Proposals are to be submitted electronically on BidNet Direct ([www.bidnetdirect.com](http://www.bidnetdirect.com)). Please review the submission requirements **well in advance** of submission date and time, and allow for ample time to upload each required document. It is recommended that Offerors begin the submission process at least one (1) day in advance of the proposal deadline.

Offerors are solely responsible to ensure all required proposal documents are uploaded and submitted correctly, and that a **confirmation number** is obtained upon successful submission. Customer support for BidNet Direct may be reached at (800) 835-4603.

\*\*\*\*\***NO LATE OFFERS WILL BE ACCEPTED**\*\*\*\*\*

**Date/Time**: Proposals shall be received on or before Time MST, Day, Date.

### **Identification of Proposal:**

Proposals must be submitted to the BidNet Direct Procurement Platform ([www.bidnetdirect.com](http://www.bidnetdirect.com)). The solicitation number and Offeror name must be clearly marked within the proposal.

Proposal No.: R24-115MZ

Due Date and Time: October 15, 2024 2:00PM

Any offer that is submitted without being properly marked may be opened for identification prior to the deadline for receipt of proposals and then resealed.

## 1.3 NUMBER OF COPIES

Offerors shall submit **one (1)** softcopy to the BidNet Direct platform. Upon submission, all proposal documents shall become and remain the property of the City of Colorado Springs.

## 1.4 SPECIAL TERMS

Please note the following definitions of terms as used herein:

The term “City” means the City of Colorado Springs.

The term “Contractor” or “Consultant” means the Offeror whose offer is accepted and is awarded the contract to provide the products or services specified in the RFP.

The term “Offer” means the proposal.

The term “Offeror” means the person, firm, or corporation that submits a formal proposal or offer and that may or may not be successful in being awarded the contract.

The term “Project” refers to Memorial Park War Memorial Construction.



The term “Request for Proposal” or “RFP” means this solicitation of a formal, negotiable proposal/offer. Any offer that is accepted will be the offer that is deemed by the City of Colorado Springs to be most advantageous in terms of the criteria designated in the RFP.

### **1.5 RFP OBJECTIVE**

The objective of this RFP is to provide sufficient information to enable qualified Offerors to submit written proposals to the City of Colorado Springs. The RFP is not a contractual offer or commitment to purchase products or services. The Offeror may present options and variables to the scope while still meeting the minimum requirements of this solicitation. Innovative proposals/solutions are encouraged and considered in the selection and/or award.

All information included in proposals must be legible. Any and all corrections and or erasures must be initialed by Offeror. Each proposal shall be accompanied by a cover letter signed by an authorized representative of the Offeror. The contents of the proposal submitted by the successful Offeror may become part of any contract awarded as a result of this solicitation.

### **1.6 CONFIDENTIAL OR PROPRIETARY INFORMATION**

If an Offeror believes that parts of an offer are confidential, then the Offeror must so specify. The Offeror must include in bold letters the term “CONFIDENTIAL” on that part of the offer which the Offeror believes to be confidential. The Offeror must submit in writing specific detailed reasons, including any relevant legal authority, stating why the Offeror believes the material to be confidential. Vague and general claims as to confidentiality will not be accepted. The City of Colorado Springs will be the sole judge as to whether a claim is acceptable. Decisions regarding the confidentiality of information will be made when requests are made to make the information public. All offers and parts of offers, which are not marked as confidential, will automatically be considered public information after the contract is awarded. The successful offer may be considered public information even though parts are marked confidential.

### **1.7 AMENDMENTS**

Amendments to this RFP may be issued at any time prior to the time set for receipt of proposals. Offerors are required to acknowledge receipt of any amendments issued to this RFP by returning a signed copy of each amendment issued. Signed copies of each amendment must be received on or before the time set for receipt of offers.

The City of Colorado Springs will post all amendments on BidNet Direct under the Rocky Mountain E-Purchasing Group ([www.BidNetDirect.com](http://www.BidNetDirect.com)). It is the Offeror's responsibility to check the website for posted amendments or contact the Contracts Specialist listed in RFP §1.1 to confirm the number of amendments which have been issued.

### **1.8 WITHDRAWAL OR MODIFICATION OF OFFERS**

Any Offeror may modify or withdraw an offer in writing at any time prior to the deadline for submission of an offer.



## **1.9 ACCEPTANCE**

Any offer received and not withdrawn shall be considered an offer, which may be accepted by the City of Colorado Springs based on initial submission without discussions or negotiations.

By submitting an offer in response to this solicitation, the Offeror agrees that any offer it submits may be accepted by the City of Colorado Springs at any time within 90 calendar days from the date of submission deadline.

The City of Colorado Springs reserves the right (a) to reject any or all offers, (b) to waive informalities and minor irregularities in offers received, and/or (c) to accept any portion of an offer if deemed in the best interest of the City of Colorado Springs. Failure of the Offeror to provide in its offer any information requested in the RFP may result in rejection of the offer for non-responsiveness.

## **1.10 PROPOSAL PREPARATION COST**

The cost of proposal preparation is not a reimbursable cost. Proposal preparation shall be at the Offeror's sole expense and is the Offeror's total and sole responsibility.

## **1.11 AWARD**

The City of Colorado Springs intends to make an award using the evaluation criteria listed in this RFP to determine the best value, considering all factors and criteria in the proposals submitted. Best value means the expected outcome of an acquisition that, in the City's estimation, provides the greatest overall benefit in response to the requirements detailed in the RFP. The City of Colorado Springs reserves the right to reject any or all offers and to not make an award.

## **1.12 PERFORMANCE PERIOD**

The performance period for the project detailed in this RFP will be established as **NOTICE TO PROCEED THROUGH OCTOBER 31, 2025.**

## **1.13 DEBRIEFING**

Offerors not selected may request a debriefing on the selection process as well as discussion of the strengths and weaknesses of their proposal upon receipt of notification that their offer was not selected.

A debriefing may be scheduled by contacting the Contracts Specialist listed above. The Contracts Specialist must receive a written request for debriefing no later than ten (10) calendar days after issuance of a notification that the Offeror's offer was not selected.

## **1.14 SUBSTANTIVE PROPOSALS**

By responding to this RFP, the Offeror certifies (a) that Offeror's proposal is genuine and is not made in the interest of, or on behalf of, an undisclosed person, firm, or corporation; (b) that Offeror has not directly or indirectly induced or solicited any other offerors to put in a false or sham proposal; (c) that Offeror has not solicited or induced any other person, firm, or corporation to



refrain or abstain from proposing an offer or proposal; (d) that Offeror has not sought by collusion to obtain for themselves any advantage over any other offerors or over the City of Colorado Springs; and (e) that Offeror has not violated or caused any person to violate, and shall not violate or cause any person to violate, the City's Code of Ethics contained in Article 3, of Chapter 1 of the City Code and in the City's Procurement Rules and Regulations.

### **1.15 OFFEROR'S QUALIFICATIONS**

Each Offeror must complete Exhibit 1 – Qualification Statement.

No contract will be awarded to any Offeror who is in arrears to the City, upon any debt or contract, or who is in default, in any capacity, upon any obligation to the City or is deemed to be irresponsible or unreliable by the City based on past performance.

### **1.16 NON-COLORADO ENTITIES**

If Offeror is a foreign entity, Offeror shall comply with C.R.S. section 7-90-801, "Authority to transact business or conduct activities required," and section 7-90-802, "Consequences of transacting business or conducting activities without authority."

Before or at the time that the contract is awarded to an entity organized or operating outside the State of Colorado, such entity shall obtain authorization to do business in the State of Colorado, designate a place of business herein, and appoint an agent for service of process.

Such entity must furnish the City of Colorado Springs with a certificate from the Secretary of the State of Colorado to the effect that a certificate of authority to do business in the State of Colorado has been issued by that office and is still valid. The entity shall also provide the City with a certified copy of the designation of place of business and appointment of agent for service of process from the Colorado Secretary of State, or a letter from the Colorado Secretary of State that such designation of place of business and agent for service of process has been made.

### **1.17 PROCUREMENT RULES AND REGULATIONS**

All projects advertised by the City of Colorado Springs are solicited in accordance with the City's Procurement Rules and Regulations. The City's Procurement Rules and Regulations can be reviewed and/or downloaded from the City website [www.coloradosprings.gov](http://www.coloradosprings.gov). The Contracts Specialist may also provide a softcopy of the Rules and Regulations upon request. Any discrepancies regarding conflicting statements, decisions, irregularities, clauses, or specifications will be rectified utilizing the City's Procurement Rules and Regulations, when applicable. It is the Offeror's responsibility to advise the Contracts Specialist listed in this RFP of any perceived discrepancies prior to the date and time the offer is due.

### **1.18 FAIR TREATMENT OF OFFERORS**

The City Procurement Services Division shall be responsible for ensuring the procurement of products, commodities, and services are in a manner that affords all responsible businesses a fair and equal opportunity to compete. If an Offeror believes that a procurement is not conducted in a fair and equitable manner, the Offeror is encouraged to inform the City Procurement Services Manager as soon as possible.





## 1.19 ORDER OF PRECEDENCE

Any inconsistency in this solicitation shall be resolved by giving precedence in the following order:

- A. Sections I-IV of this Solicitation
- B. Special Construction Terms and Conditions
- C. General Construction Terms and Conditions
- D. Exhibits
- E. Plans
- F. Detailed Plans
- G. Standard Drawings
  - a. Calculated dimensions will govern over scaled dimensions.
- H. Special Specifications
- I. Standard Specifications

## 1.20 SALES TAX

The successful Offeror, if awarded a contract, shall apply to the Colorado Department of Revenue for a tax-exempt certificate for this project. The certificate does not apply to City of Colorado Springs Sales and Use Tax which shall be applicable and should be included in all proposals. The tax exempt project number and the exemption certificate only apply to County, PPRTA (Pikes Peak Rural Transportation Authority), and State taxes when purchasing construction and building materials **to be incorporated into this project**.

Furthermore, the exemption **does not** include or apply to the purchase or rental of equipment, supplies or materials that **do not become a part of the completed project or structure**. In these instances, the purchase or rental is subject to full taxation at the current taxation rate.

The Offeror and all subcontractors shall include in their Offer City of Colorado Springs Sales and Use Tax on the work covered by the offer, and all other applicable taxes.

Forms and instructions can be downloaded at <https://coloradosprings.gov/sales-tax>. Questions can be directed to the City Sales Tax Division at (719) 385-5903 or [Construction\\_SalesTax@coloradosprings.gov](mailto:Construction_SalesTax@coloradosprings.gov).

Our Registration Numbers are as follows:

City of Colorado Springs

Federal I.D.: 84-6000573

Federal Excise: A-138557

State Sales Tax: 98-03479

## 1.21 BOND REQUIREMENTS

The Offeror is advised that the successful Offeror shall be required to furnish to the City of Colorado Springs, upon award, one copy of each: Performance Bond, Labor and Materials Payment Bond, and a Maintenance Bond in the amount of 100% of the total contract within ten (10) calendar days after notification of award of a contract. The cost of all bonds shall be included in Offeror's offer.



Bonds shall:

- A. Be for the full amount of the contract price.
- B. Guarantee the Contractor's faithful performance of the work under the contract, and the prompt and full payment for all labor and materials involved therein.
- C. Guarantee protection to the City of Colorado Springs against liens of any kind.
- D. Be, when a surety bond is furnished, from a surety company operating lawfully in the State of Colorado and be accompanied with an acceptable "Power-of-Attorney" form attached to each bond copy.
- E. Be issued from a surety company that is acceptable to the City of Colorado Springs.
- F. Be submitted using the forms in the Exhibit section of this solicitation.

### **1.22 INTERPRETATION OF QUANTITIES IN PROPOSAL FORM**

Except as otherwise provided in this RFP, the quantities appearing in the proposal form are estimates prepared for the comparison of proposals.

After award, payment to the Contractor will be made in accordance with the following procedures:

- A. Measurement required. When the Contract requires measurement of work performed or material furnished, payment will be made for actual quantities measured and accepted.
- B. Measurement Not Required. When the Contract does not require quantities of work performed or materials furnished to be measured, payment will be made for the quantities appearing in the Contract.

The estimated quantities of work to be performed and materials to be furnished may be increased, decreased or omitted.

### **1.23 INTERPRETATION OF PLANS AND SPECIFICATIONS**

Any change to proposal forms, plans, or specifications prior to the opening of proposals will be issued by the City in the form of an Amendment. Certain individuals may be named in the RFP that have authority to provide information, clarification or interpretation to Offerors prior to opening of proposals. Information obtained from persons other than those named individuals is invalid and shall not be used for proposal purposes.

### **1.24 EXAMINATION OF PLANS, SPECIFICATIONS, SPECIAL PROVISIONS, AND SITE OF WORK.**

The Offeror is expected to examine the site of the proposed work, the proposal, plans, specifications, supplemental specifications, special provisions, and Contract forms, before submitting a proposal. The submission of a proposal will be considered conclusive evidence that the Offeror has made this examination and is aware of the conditions to be encountered in performing the work according to the Contract.

Boring logs and other records of subsurface investigations, if they exist, are available for inspection by Offerors. These logs and records are made available so that all Offerors have access to identical subsurface information that is available to the City, and is not intended as a substitute for personal investigation, interpretation, and judgment of the Offerors.



The City does not warrant the adequacy of boring logs and other records of subsurface investigations, and such information is not considered to be a part of the Contract. When a log of test borings is included in the subsurface investigation record, the data shown in the individual log of each test boring apply only to that particular boring and are not intended to be conclusive as to the character of any material between or around test borings. If Offerors use this information in preparing a proposal, it is used at their own risk, and Offerors are responsible for all conclusions, deductions, and inferences drawn from such information.

Offerors may conduct subsurface investigations at the project site at Offeror's expense; the City will afford them this opportunity prior to public opening of proposals.

If an Offeror discovers an apparent error or omission in the proposal form, estimated quantities, plan, or specifications, the Offeror shall immediately notify the Contracting Specialist to enable the City to make any necessary revisions. The City may consider it to be detrimental to the City for an Offeror to submit an obviously unbalanced unit proposal price.

### **1.25 COMBINATION OR CONDITIONAL PROPOSALS**

If an RFP is issued for projects in combination and separately, the Offeror may submit proposals either on the combination or on separate units of the combination. The City reserves the right to make awards on combination or separate proposals to the advantage of the City. Combination proposals will be considered, only when specified.

### **1.26 ANTI-COLLUSION AFFIDAVIT**

The Offeror by signing their proposal submitted to the City is certifying that the Offeror has not participated in any collusion or taken any action in restraint of free competitive bidding. This statement may also be in the form of an affidavit provided by the City and signed by the Offeror. The original of the signed anti-collusion affidavit, if separately required and provided with the RFP, shall be submitted with the proposal. The proposal will be rejected if it does not contain the completed anti-collusion affidavit.

### **1.27 MATERIAL GUARANTY**

The successful Offeror may be required to furnish a complete statement of the origin, composition, and manufacture of materials used in the construction of the work together with samples, which will be tested for conformance with Contract requirements.



## SECTION II – PROPOSAL CONTENT

### 2.0 PROPOSAL CONTENT

- A. Section II provides instructions regarding the format and content required for proposals submitted in response to this solicitation.

### 2.1 PROPOSAL FORMAT

Offeror's written proposal should include concise, but complete, information, emphasizing why the Offeror is best or best qualified to provide the required services. The Offeror's written proposal should include the information in the format outlined below and must be limited to no more than twenty-five (25) pages. **A page shall be defined as 8-1/2" x 11"; single sided, with one inch margins, and a minimum font of Times New Roman 10.** The only exception to the 8-1/2" x 11" paper size is the proposed project schedule. It may be submitted on 11" x 17" paper. Each 11" x 17" page for the schedule shall be counted in the overall page limitations above. Each section of the proposal should be labeled to clearly follow the requirements sections identified in this section of the RFP. The following listed Exhibits must be filled out and returned with the proposal and are not counted against the page limit:

Exhibit 1	Qualifications Documents
Exhibit 4	Federal Forms
Schedule A	Price Sheet
Addendum if issued	

### 2.2 COVER LETTER

The cover letter shall be no more than two pages. The cover letter shall contain at least the following information.

- A. RFP Number and Project Name.
- B. Statement that the Offeror is qualified to perform the work.
- C. Certification Statement that the information and data submitted are true and complete to the best knowledge of the individual signing the letter.
- D. Name, telephone number, email address, and physical address of the individual to contact regarding the proposal.
- E. The signature of an authorized principal, partner, or officer of the Offeror.

### 2.3 PROPOSAL CERTIFICATION

The Offeror must fill out and submit Exhibit 1 with its Proposal.

### 2.4 ORGANIZATIONAL BACKGROUND AND OVERVIEW

The Offeror must provide a brief history and overview of its company and its organizational structure, with special emphasis on how this project will fit within that structure. Also include principal place of business location(s), office locations, size of firm, and financial stability (annual public reports or private financial statements shall be included in an appendix or under separate cover; private financial information will be kept confidential by the City).



## **2.5 PROPOSAL NARRATIVE/TECHNICAL AND MANAGEMENT APPROACH**

In the proposal narrative/technical and management approach section, the Offeror should explain what the Offeror will do and how it will perform if awarded a contract.

### **2.5.1 TECHNICAL AREA**

The Offeror must explain its overall solution, considering the scope of work or statement of work provided. The content must include, but not necessarily be limited to, the following information.

#### **A. Understanding of and Compliance with Technical Requirements**

In the Technical Area, the Offeror should address each work area in sufficient detail to demonstrate a clear and full understanding of the work necessary to complete the project. The proposal should not merely parrot the requirements of the RFP. Further, the Offeror should provide evidence of sufficient planning to ensure the work is completed on schedule and within budget. It is highly recommended that the Offeror provide sufficient content and detail to answer completely the following questions:

1. Does the proposal demonstrate a firm understanding of the requirements and goals of the Statement of Work, as well as industry standards and reasonable expectations for a company in the industry?
2. Does the proposal fully and completely address each requirement and goal of the Statement of Work and Plan Set Work List Table?
3. Does the proposal provide solutions to indicate that requirements and goals will be met on schedule?
4. Does the technical solution seem realistic?
5. Does it generally appear that the Offeror knows and thoroughly understands the business and the RFP requirements?

#### **B. Project Approach**

In the Technical Area, the Offeror should clearly present proposed solutions and indicate that it has performed adequate planning to accomplish project tasks as defined in the Statement of Work. Innovations, efficiencies, and detailed specifics are all encouraged.

The Offeror must at least address the following areas:

1. Construction phasing and traffic control for the project. Explain the phases, traffic control for each phase, and the logic in the construction phasing.
2. Erosion and sediment control during all phases of construction as well as post construction efforts through permit closure.
3. Coordination with utilities. Discuss Offeror's understanding of the key utility relocations required for this project and how Offeror will coordinate and phase construction to both facilitate and accommodate those relocations and the constraints that they impose.
4. Schedule Management. Discuss Offeror's approach to schedule management



- including updating and reporting progress of the work.
5. Quality Control. Discuss Offeror's quality control plan, processes and approach to ensure that the City receives a quality product.
  6. Safety. Discuss Offeror's approach and commitment to safety for both construction workers and the public traveling through the construction site.
  7. Potential issues that Offeror foresees with this project and how Offeror would make adjustments if encountered. Describe factors limiting construction phasing flexibility and potential remedies.

It is highly recommended that the Offeror provide sufficient content and detail to answer completely the following questions.

1. Does the proposal include a complete plan to accomplish each requirement, including subcontracting (if applicable)?
2. Does the proposal demonstrate that appropriate and qualified personnel and equipment will be provided to carry out the requirement?
3. Is the proper level of effort directed toward each requirement? Does the level of effort look unrealistically low or unreasonably high?

## **2.5.2 MANAGEMENT AREA**

The Offeror must explain its method of managing the work to be performed. The content must include, but no necessarily be limited to, the following information.

### **A. Program Management Controls**

In the Management Area, the Offeror should provide:

1. A plan of operation, to include management of personnel, workload, schedule, and budget
2. An organization chart which demonstrates clear and effective lines of authority, responsibility, and communication for management, supervisory, and technical personnel. The plan should address which job classification or personnel will be assigned to each task and how that determination is made. Basic human resource management concepts should be addressed, including hiring, firing, discipline, incentive plans, etc.
3. If the Offeror plans to subcontract more than 10% of the work, include information on how the Offeror plans to manage its subcontractors.
4. A detailed construction schedule for the project showing the key construction activities and how they will meet or improve the City's timeframe and maximize construction efficiency to provide the best value to the City and minimize impacts to the public such as avoiding closures on Veterans Day and Memorial Day holidays. The schedule shall be based on the Offeror's understanding and approach to the work as addressed above. Schedules should address controls to ensure the project will remain on schedule and on budget. Schedules submitted for this project shall assume a start date of October 2024..

It is highly recommended that the Offeror provide sufficient content and detail to answer completely the following questions.



1. Does the proposal address the issues above in sufficient detail to demonstrate a sophisticated and mature management control system?
2. Are program management controls consistent with the technical portion of the proposal, especially regarding schedule and level of effort?
3. Do the plan and controls indicate that the Offeror will obtain, keep, and efficiently utilize high-quality personnel?
4. Does the proposal explain how the Offeror will address corrective actions in case of delays (e.g. expediting materials, additional resources, etc.)?
5. Does the proposal explain how the Offeror will remain within schedule and budget?

#### B. Past Performance/Relevant Experience and Key Personnel

In the Management Area, the Offeror should provide at least three references or name contracts demonstrating that it successfully provided services/products that are the same or similar to those required in the RFP. The proposal should adequately explain how the projects were completed on schedule and within budget. It is highly recommended that the Offeror provide sufficient content and detail to answer completely the following questions.

1. Does the proposal include at least three references or past performance citations?
2. Are the references or past performance citations relevant to the requirements of the Statement of Work of the RFP?
3. Does the Offeror explain how they were successful on the projects provided as past performance?
4. Does the Offeror apply the past performance to the City requirement in such a way as to demonstrate added value due to experience?

#### C. Key Personnel

In the Management Area, resumes must be provided for all personnel considered key, as required by the RFP. Resumes do not count toward the page limit. It is highly recommended that the Offeror provide sufficient content and detail to answer completely the following questions. Explain how the key personnel were related to the projects cited as relevant past performance.

1. Does the Offeror provide complete resumes, including education, experience, background information, accomplishments, and other pertinent information?
2. Does the Offeror provide resumes for all key personnel, as required by the RFP?
3. Do the resumes demonstrate adequate professional, technical, and management levels to accomplish the work effectively and efficiently?

## 2.6 PRICE AREA

In the Price Area, the Offeror should provide a detailed breakdown of the price for each year of performance. The price must be all-inclusive and include all unit costs for material, labor, other direct costs (e.g. travel), indirect costs (i.e. overhead and general and administrative costs), and profit/fee. Offers must include sufficient detail to allow insight into the fairness and reasonableness



of the price. If the contract type will be Time and Material (T&M) labor categories, labor rates, separated profit, and estimated material costs must be included in detail.

In addition, although price may not be the most important factor, it is still very important to the City of Colorado Springs. The Offeror's pricing must be competitive as compared to the budget amount, market pricing in the industry, and the pricing of other Offerors. It is highly recommended that the Offeror provide sufficient content and detail to answer completely the following questions.

1. How does the price compare to the industry competition?
2. If low, is it unrealistically low?
3. If high, is there demonstrated added value for the additional cost?

## **2.7 PROPOSAL PRESENTATION**

Presentation is an important factor. Offerors should provide a highly professional product, which is complete, accurate, easily understood, and effectively presented.

## **2.8 EXCEPTIONS**

All Offerors must complete Exhibit 1, Exceptions Form and return it with their proposal. Some terms and conditions are not negotiable. Exceptions may be grounds for rendering the proposal unacceptable without further discussions.

## **2.9 INSURANCE REQUIREMENTS**

All Offerors must complete Exhibit 1, Minimum Insurance Requirements and return with their proposal. Lack of responsiveness in this area may be grounds for rendering the proposal unacceptable without further discussions.





## **SECTION III – EVALUATION FACTORS**

### **3.0 EVALUATION AND AWARD**

Section III provides information regarding evaluation criteria and scoring. It also includes information regarding proposal selection and award of the resultant contract.

### **3.1 EVALUATION CRITERIA**

#### **3.1.1 TECHNICAL AREA – UNDERSTANDING OF AND COMPLIANCE WITH TECHNICAL REQUIREMENTS**

See Section II - Item 2.5.1A

#### **3.1.2 TECHNICAL AREA – PROJECT APPROACH**

See Section II - Item 2.5.1B

#### **3.1.3 MANAGEMENT AREA – PROGRAM MANAGEMENT CONTROLS**

See Section II - Item 2.5.2A

#### **3.1.4 MANAGEMENT AREA – PAST PERFORMANCE/RELEVANT EXPERIENCE/KEY PERSONNEL**

See Section II – Item 2.5.2B

#### **3.1.5 PRICE/COST AREA – PRICE/COST**

See Section II – Item 2.6

#### **3.1.6 PROPOSAL PRESENTATION AREA – PROPOSAL PRESENTATION**

See Section II – Item 2.7

#### **3.1.7 EXCEPTIONS AND INSURANCE**

See Section II – Items 2.8 and 2.9

### **3.2 RANKING**

A. The order of ranking or importance in the evaluation shall be as follows:

First: Price/Cost Area  
Second: Technical Area  
Third: Management Area  
Fourth: Proposal Presentation Area

B. Possible scores for each criterion shall be as follows:

5 – Exceptional  
4 – Very Good  
3 – Satisfactory  
2 – Marginal  
1 – Unacceptable



C. Definitions for scoring are as follows:

Exceptional – The proposal meets all and exceeds many of the requirements of the RFP to the benefit of the City, and the information provided is of such a nature as to answer all questions without need for further inquiry. There are no corrective actions required, and no compromise of requirements is needed.

Very Good – The proposal meets all and exceeds some of the requirements of the RFP to the benefit of the City, and the information provided is of such a nature as to answer most questions without need for further inquiry. There are no corrective actions required, and no compromise of requirements is needed.

Satisfactory – The proposal meets the requirements of the RFP, and the information provided is of such a nature as to answer many questions without need for further inquiry. There are very few corrective actions required, and no substantive compromise of requirements is needed.

Marginal – The proposal does not meet some of the requirements of the RFP, and the information provided is of such a nature as to require some clarification. There are some corrective actions required, and some non-substantive compromise of requirements is needed.

Unacceptable – The proposal does not meet many of the requirements of the RFP, and the information provided is of such a nature as to require much clarification. There are many corrective actions required, and substantive compromise of requirements is needed.

D. Area Scoring

The score for each area will be determined by multiplying the sum of the criteria in each area by the area evaluation factor. The area evaluation factors are as follows:

Price/Cost Area: .35  
Technical Area: .30  
Management Area: .25  
Proposal Presentation Area: .10

E. Final/Overall Scoring

The final proposal score will be determined by adding the area scoring. The sum of the area scores will be the final/overall score.

### **3.3 SELECTION COMMITTEE**

A selection committee will review all proposals. Through this process, the City will determine which proposals are acceptable or unacceptable. The City will notify, in writing, the Offerors whose proposals are deemed to be unacceptable. Those Offerors offering proposals deemed to be acceptable by the City will be evaluated and scored by the selection committee. This scoring will determine which Offerors are considered to be in the competitive range and may be the basis for an award decision without further steps.



If the selection committee elects not to award based upon evaluation scoring, it may engage in a forced elimination process. To inform this process, it may require oral presentations or interviews with the Offerors considered to be in the competitive range. If oral presentations or interviews are conducted, they may also be scored, or they may simply be considered as information supporting the forced elimination process. The selection committee may request revisions to the proposal from each of the Offerors at the conclusion of the interviews. The intent of the forced elimination process is to reach consensus. The decision will be based on all relevant factors, and based upon perception of best value. The final decision may or may not exactly reflect scoring ranking.

The City also reserves the right to request best and final offers from all Offerors at any point in the proposal evaluation process.

### **3.4 AWARD OF CONTRACT**

It is anticipated that there will be negotiations or discussions with Offerors. However, the City reserves the right to award without negotiations or discussions. The City also reserves the right to award a contract not necessarily or merely to the Offeror with the most advantageous price. The City intends to award to the Offeror that demonstrates the best value to the City and the most substantiated ability to fulfill the requirements contained in this Request for Proposal. A contract prepared by the City will be finalized and/or negotiated with the successful Offeror. In the event a contract cannot be negotiated with the top ranked Offeror, the City may enter into negotiations with the second highest ranked Offeror, or the City may decide to call for new proposals. Immediately after the notice of award, the successful Offeror will begin planning in conjunction with the City of Colorado Springs staff (to be designated by the City) to ensure fulfillment of all its obligations. The successful Offeror may be expected to attend regular meetings as required by the City to assist in the preparation for startup.



## SECTION IV – SPECIAL CONTRACT TERMS AND CONDITIONS

### 4.0 SPECIAL CONTRACT TERMS AND CONDITIONS/SPECIAL SOLICITATION PROVISIONS

In addition to the special contract terms and conditions listed below, the City's sample contract, see Exhibit 2, contains contract terms and conditions.

**ADA Standards:** It is a requirement of the City and required by law that any new or renovated facility meet the scoping and technical requirements of the 2010 ADA Standards for newly designed and constructed or altered local government facilities, public accommodations, and facilities. The selected Design Professional shall design the project so it both conforms to the 2010 ADA Standards, as applicable and as amended, and is readily accessible to and usable by individuals with disabilities. The selected Contractor shall build the project so it both conforms to the 2010 ADA Standards, as applicable and as amended, and is readily accessible to and usable by individuals with disabilities. Facilities that are designed, constructed, and/or altered facilities that meet or exceed the IBC 2015/ANSI A117.1 2009, used by Pikes Peak Regional Building Department, will be accepted as meeting or exceeding the 2010 ADA Standards.

### CLAUSES FOR CONTRACTS SUBJECT TO FEDERAL REQUIREMENTS

#### 1. EQUAL EMPLOYMENT OPPORTUNITY

To view the City of Colorado Springs EEOP (Equal Employment Opportunity Plan) Utilization Report, the link is [www.coloradosprings.gov/eeop](http://www.coloradosprings.gov/eeop).

During the performance of this Contract, the Contractor agrees as follows:

A. The Contractor will not discriminate against any employee or applicant for employment because of race, color, religion, sex, or national origin. The Contractor will take affirmative action to ensure that applicants are employed, and that employees are treated during employment without regard to their race, color, religion, sex, or national origin. such action shall include, but not be limited to the following: Employment, upgrading, demotion, or transfer; recruitment or recruitment advertising; layoff or termination; rates of pay or other forms of compensation; and selection for training, including apprenticeship. The Contractor agrees to post in conspicuous places, available to employees and applicants for employment, notices to be provided setting forth the provisions of this nondiscrimination clause.

B. The Contractor will, in all solicitations or advertisements for employees placed by or on behalf of the Contractor, state that all qualified applicants will receive considerations for employment without regard to race, color, religion, sex, or national origin.

C. The Contractor will send to each labor union or representative of workers with which he has a collective bargaining agreement or other contract or understanding, a notice to be provided advising the said labor union or workers' representatives of the contractor's commitments under this section, and shall post copies of the notice in conspicuous places available to employees and applicants for employment.



D. The Contractor will comply with all provisions of Executive Order 11246 of September 24, 1965, and of the rules, regulations, and relevant orders of the Secretary of Labor.

E. The Contractor will furnish all information and reports required by Executive Order 11246 of September 24, 1965, and by rules, regulations, and orders of the Secretary of Labor, or pursuant thereto, and will permit access to his books, records, and accounts by the administering agency and the Secretary of Labor for purposes of investigation to ascertain compliance with such rules, regulations, and orders.

F. In the event of the Contractor's noncompliance with the nondiscrimination clauses of this contract or with any of the said rules, regulations, or orders, this contract may be canceled, terminated, or suspended in whole or in part and the Contractor may be declared ineligible for further Government contracts or federally assisted construction contracts in accordance with procedures authorized in Executive Order 11246 of September 24, 1965, and such other sanctions may be imposed and remedies invoked as provided in Executive Order 11246 of September 24, 1965, or by rule, regulation, or order of the Secretary of Labor, or as otherwise provided by law.

G. The Contractor will include the portion of the sentence immediately preceding paragraph (1) and the provisions of paragraphs (1) through (7) in every subcontract or purchase order unless exempted by rules, regulations, or orders of the Secretary of Labor issued pursuant to section 204 of Executive Order 11246 of September 24, 1965, so that such provisions will be binding upon each subcontractor or vendor. The Contractor will take such action with respect to any subcontract or purchase order as the administering agency may direct as a means of enforcing such provisions, including sanctions for noncompliance: *Provided, however*, that in the event the Contractor becomes involved in, or is threatened with, litigation with a subcontractor or vendor as a result of such direction by the administering agency the Contractor may request the United States to enter into such litigation to protect the interests of the United States.

*H. Subcontracts.* Each nonexempt prime contractor or subcontractor shall include the equal opportunity clause in each of its nonexempt subcontracts.

*I. Incorporation by reference.* The equal opportunity clause may be incorporated by reference in all Government contracts and subcontracts, including Government bills of lading, transportation requests, contracts for deposit of Government funds, and contracts for issuing and paying U.S. savings bonds and notes, and such other contracts and subcontracts as the Deputy Assistant Secretary may designate.

*J. Incorporation by operation of the order.* By operation of the order, the equal opportunity clause shall be considered to be a part of every contract and subcontract required by the order and the regulations in this part to include such a clause whether or not it is physically incorporated in such contracts and whether or not the contract between the agency and the contractor is written.

*K. Adaptation of language.* Such necessary changes in language may be made in the equal opportunity clause as shall be appropriate to identify properly the parties and their undertakings. [43 FR 49240, Oct. 20, 1978, as amended at 62 FR 66971, Dec. 22, 1997]

## **2. EQUAL EMPLOYMENT OPPORTUNITY REPORTS AND OTHER REQUIRED INFORMATION**



A. *Requirements for prime contractors and subcontractors.*

1. Each prime contractor and subcontractor shall file annually, on or before the September 30, complete and accurate reports on Standard Form 100 (EEO-1) promulgated jointly by the Office of Federal Contract Compliance Programs, the Equal Employment Opportunity Commission and Plans for Progress or such form as may hereafter be promulgated in its place if such prime contractor or subcontractor (i) is not exempt from the provisions of these regulations in accordance with § 60-1.5; (ii) has 50 or more employees; (iii) is a prime contractor or first tier subcontractor; and (iv) has a contract, subcontract or purchase order amounting to \$50,000 or more or serves as a depository of Government funds in any amount, or is a financial institution which is an issuing and paying agent for U.S. savings bonds and savings notes: *Provided*, That any subcontractor below the first tier which performs construction work at the site of construction shall be required to file such a report if it meets requirements of paragraphs (a)(1) (i), (ii), and (iv) of this section.

2. Each person required by § 60-1.7(a)(1) to submit reports shall file such a report with the contracting or administering agency within 30 days after the award to him of a contract or subcontract, unless such person has submitted such a report within 12 months preceding the date of the award. Subsequent reports shall be submitted annually in accordance with § 60-1.7(a)(1), or at such other intervals as the Deputy Assistant Secretary may require. The Deputy Assistant Secretary may extend the time for filing any report.

3. The Deputy Assistant Secretary or the applicant, on their own motions, may require a contractor to keep employment or other records and to furnish, in the form requested, within reasonable limits, such information as the Deputy Assistant Secretary or the applicant deems necessary for the administration of the order.

4. Failure to file timely, complete and accurate reports as required constitutes noncompliance with the prime contractor's or subcontractor's obligations under the equal opportunity clause and is ground for the imposition by the Deputy Assistant Secretary, an applicant, prime contractor or subcontractor, of any sanctions as authorized by the order and the regulations in this part.

B. *Requirements for bidders or prospective contractors—*

1. *Certification of compliance with Part 60-2: Affirmative Action Programs.* Each agency shall require each bidder or prospective prime contractor and proposed subcontractor, where appropriate, to state in the bid or in writing at the outset of negotiations for the contract: (i) Whether it has developed and has on file at each establishment affirmative action programs pursuant to Part 60-2 of this chapter; (ii) whether it has participated in any previous contract or subcontract subject to the equal opportunity clause; (iii) whether it has filed with the Joint Reporting Committee, the Deputy Assistant Secretary or the Equal Employment Opportunity Commission all reports due under the applicable filing requirements.

2. *Additional information.* A bidder or prospective prime contractor or proposed subcontractor shall be required to submit such information as the Deputy Assistant Secretary requests prior to the award of the contract or subcontract. When a determination



has been made to award the contract or subcontract to a specific contractor, such contractor shall be required, prior to award, or after the award, or both, to furnish such other information as the applicant or the Deputy Assistant Secretary requests.

C. *Use of reports.* Reports filed pursuant to this section shall be used only in connection with the administration of the order, the Civil Rights Act of 1964, or in furtherance of the purposes of the order and said Act.[43 FR 49240, Oct. 20, 1978, as amended at 62 FR 66971, Dec. 22, 1997]

**3. RESERVED (DAVIS-BACON WAGES DO NOT APPLY)**

**4. CONTRACT WORK HOURS AND SAFETY STANDARDS (from FAR 52.222-4)**

The term “Contracting Officer” herein shall refer to the City of Colorado Springs Contracting Specialist assigned to this contract.

The term “Government” herein shall refer to the City of Colorado Springs and any interested federal or state entity.

A. *Overtime requirements.* No Contractor or subcontractor employing laborers or mechanics (see Federal Acquisition Regulation 22.300) shall require or permit them to work over 40 hours in any workweek unless they are paid at least 1 and 1/2 times the basic rate of pay for each hour worked over 40 hours.

B. *Violation; liability for unpaid wages; liquidated damages.* The responsible Contractor and subcontractor are liable for unpaid wages if they violate the terms in paragraph (a) of this clause. In addition, the Contractor and subcontractor are liable for liquidated damages payable to the Government. The Contracting Officer will assess liquidated damages at the rate of \$10 per affected employee for each calendar day on which the employer required or permitted the employee to work in excess of the standard workweek of 40 hours without paying overtime wages required by the Contract Work Hours and Safety Standards statute (found at 40 U.S.C. chapter 37).

C. *Withholding for unpaid wages and liquidated damages.* The Contracting Officer will withhold from payments due under the contract sufficient funds required to satisfy any Contractor or subcontractor liabilities for unpaid wages and liquidated damages. If amounts withheld under the contract are insufficient to satisfy Contractor or subcontractor liabilities, the Contracting Officer will withhold payments from other Federal or federally assisted contracts held by the same Contractor that are subject to the Contract Work Hours and Safety Standards statute

**D. Payrolls and basic records.**

1. The Contractor and its subcontractors shall maintain payrolls and basic payroll records for all laborers and mechanics working on the contract during the contract and shall make them available to the Government until 3 years after contract completion. The records shall contain the name and address of each employee, social security number, labor classifications, hourly rates of wages paid, daily and weekly number of hours worked, deductions made, and actual wages paid. The records need not duplicate those required for construction work by Department of Labor regulations at 29 CFR 5.5(a)(3) implementing the Construction Wage Rate Requirements statute.



2. The Contractor and its subcontractors shall allow authorized representatives of the Contracting Officer or the Department of Labor to inspect, copy, or transcribe records maintained under paragraph (d)(1) of this clause. The Contractor or subcontractor also shall allow authorized representatives of the Contracting Officer or Department of Labor to interview employees in the workplace during working hours.

E. *Subcontracts*. The Contractor shall insert the provisions set forth in paragraphs (a) through (d) of this clause in subcontracts that may require or involve the employment of laborers and mechanics and require subcontractors to include these provisions in any such lower tier subcontracts. The Contractor shall be responsible for compliance by any subcontractor or lower-tier subcontractor with the provisions set forth in paragraphs (a) through (d) of this clause.

## **5. CLEAN AIR ACT**

By signing this Contract, the Contractor agrees to comply with all applicable standards, orders, or regulations issued pursuant to the Clean Air Act (42 U.S.C. 7401-7671q) and the Federal Water Pollution Control Act as amended (33 U.S.C. 1251-1387). Violations must be reported to the Federal awarding agency and the Regional Office of the Environmental Protection Agency (EPA). Further, the Contractor agrees to include this clause in all subcontracts in excess of \$150,000.

## **6. DEBARMENT AND SUSPENSION**

By signing this Contract, the Contractor certifies to the best of its knowledge and belief that it and its principals:

A. Are not presently debarred, suspended, proposed for debarment, declared ineligible, or voluntarily excluded from covered transactions by any Federal department or agency;

B. Have not within a three year period preceding this proposal been convicted of or had a civil judgment rendered against them for commission of fraud or a criminal offense in connection with obtaining, attempting to obtain, or performing a public (Federal, State, or local) transaction or contract under a public transaction; violation of Federal or State antitrust statutes or commission of embezzlement, theft, forgery, falsification or destruction of records, making false statements, or receiving stolen property;

C. Are not presently indicted for or otherwise criminally or civilly charged by a government entity (Federal, State, or local) with commission of any of the offenses enumerated in paragraph (1)(b) of this certification; and

D. Have not within a three-year period preceding this application/proposal had one or more public transactions (Federal, State, or local) terminated for cause or default.

## **7. BYRD ANTI-LOBBYING AMENDMENT**

By signing this Contract, the Contractor certifies that it will not and has not used Federal appropriated funds to pay any person or organization for influencing or attempting to influence an officer or employee of any agency, a member of Congress, officer or employee of Congress, or an employee of a member of Congress in connection with obtaining any Federal contract, grant





or any other award covered by 31 U.S.C. 1352. Further, the Contractor certifies that it has not engaged in lobbying with non-Federal funds that takes place in connection with obtaining any Federal award. The Contractor must require the same certification from all subcontractors with subcontracts valued in excess of \$100,000 under this Contract.

## **8. SMALL BUSINESS REQUIREMENTS**

The Contractor must take all necessary affirmative steps to assure that minority businesses, women's business enterprises, and labor surplus area firms are used when possible.

Affirmative steps must include:

A. Placing qualified small and minority businesses and women's business enterprises on subcontract solicitation lists.

B. Assuring that small and minority businesses, and women's business enterprises are solicited whenever they are potential sources for subcontracting.

C. Dividing total requirements, when economically feasible, into smaller tasks or quantities to permit maximum participation by small and minority businesses, and women's business enterprises.

D. Establishing delivery schedules, where the requirement permits, which encourage participation by small and minority businesses, and women's business enterprises.

E. Using the services and assistance, as appropriate, of such organizations as the Small Business Administration and the Minority Business Development Agency of the Department of Commerce.

## **9. PROCUREMENT OF RECOVERED MATERIALS**

The Contractor must comply with section 6002 of the Solid Waste Disposal Act, as amended by the Resource Conservation and Recovery Act. The requirements of Section 6002 include procuring only items designated in guidelines of the Environmental Protection Agency (EPA) at 40 CFR part 247 that contain the highest percentage of recovered materials practicable, consistent with maintaining a satisfactory level of competition, where the purchase price of the item exceeds \$10,000 or the value of the quantity acquired by the preceding fiscal year exceeded \$10,000; procuring solid waste management services in a manner that maximizes energy and resource recovery; and establishing an affirmative procurement program for procurement of recovered materials identified in the EPA guidelines.

## **10. ANTI-KICKBACK PROCEDURES**

A. Definitions.

1. "Kickback," as used in this clause, means any money, fee, commission, credit, gift, gratuity, thing of value, or compensation of any kind which is provided to any prime Contractor, prime Contractor employee, subcontractor, or subcontractor employee for the



purpose of improperly obtaining or rewarding favorable treatment in connection with a prime contract or in connection with a subcontract relating to a prime contract.

2. "Person," as used in this clause, means a corporation, partnership, business association of any kind, trust, joint-stock company, or individual.

3. "Prime contract," as used in this clause, means a contract or contractual action entered into by the United States for the purpose of obtaining supplies, materials, equipment, or services of any kind.

4. "Prime Contractor" as used in this clause, means a person who has entered into a prime contract with the United States.

5. "Prime Contractor employee," as used in this clause, means any officer, partner, employee, or agent of a prime Contractor.

6. "Subcontract," as used in this clause, means a contract or contractual action entered into by a prime Contractor or subcontractor for the purpose of obtaining supplies, materials, equipment, or services of any kind under a prime contract.

7. "Subcontractor," as used in this clause,

a. Means any person, other than the prime Contractor, who offers to furnish or furnishes any supplies, materials, equipment, or services of any kind under a prime contract or a subcontract entered into in connection with such prime contract, and

b. Includes any person who offers to furnish or furnishes general supplies to the prime Contractor or a higher tier subcontractor.

8. "Subcontractor employee," as used in this clause, means any officer, partner, employee, or agent of a subcontractor.

B. The 41 U.S.C. chapter 87, Kickbacks, prohibits any person from --

1. Providing or attempting to provide or offering to provide any kickback;

2. Soliciting, accepting, or attempting to accept any kickback; or

3. Including, directly or indirectly, the amount of any kickback in the contract price charged by a prime Contractor to the United States or in the contract price charged by a subcontractor to a prime Contractor or higher tier subcontractor.

C. The Contractor shall have in place and follow reasonable procedures designed to prevent and detect possible violations described in paragraph (b) of this clause in its own operations and direct business relationships.

When the Contractor has reasonable grounds to believe that a violation described in paragraph (b) of this clause may have occurred, the Contractor shall promptly report in writing the possible violation. Such reports shall be made to the inspector general of the contracting agency, the head



of the contracting agency if the agency does not have an inspector general, or the Attorney General.

The Contractor shall cooperate fully with any Federal agency investigating a possible violation described in paragraph (b) of this clause.

The Contracting Officer may

1. offset the amount of the kickback against any monies owed by the United States under the prime contract and/or
2. direct that the Prime Contractor withhold from sums owed a subcontractor under the prime contract the amount of the kickback. The Contracting Officer may order that monies withheld under subdivision (c)(4)(ii) of this clause be paid over to the Government unless the Government has already offset those monies under subdivision (c)(4)(i) of this clause. In either case, the Prime Contractor shall notify the Contracting Officer when the monies are withheld.

The Contractor agrees to incorporate the substance of this clause, including subparagraph (c)(5) but excepting subparagraph (c)(1), in all subcontracts under this contract which exceed \$150,000.

## **11. ENERGY EFFICIENCY IN ENERGY CONSUMING PRODUCTS**

A. Definition. As used in this clause--

1. "Energy-efficient product"—
  - a. Means a product that—
    - i. Meets Department of Energy and Environmental Protection Agency criteria for use of the Energy Star trademark label; or
    - ii. Is in the upper 25 percent of efficiency for all similar products as designated by the Department of Energy's Federal Energy Management Program.
2. The term "product" does not include any energy-consuming product or system designed or procured for combat or combat-related missions (42 U.S.C. 8259b).

B. The Contractor shall ensure that energy-consuming products are energy efficient products (i.e., ENERGY STAR® products or FEMP-designated products) at the time of contract award, for products that are—

1. Delivered.
2. Acquired by the Contractor for use in performing services at a Federally controlled facility.
3. Furnished by the Contractor for use by the Government.



4. Specified in the design of a building or work, or incorporated during its construction, renovation, or maintenance.

C. The requirements of paragraph (b) apply to the Contractor (including any subcontractor) unless:

1. The energy-consuming product is not listed in the ENERGY STAR® Program or FEMP; or

2. Otherwise approved in writing by the Contracting Officer.

D. Information about these products is available for—

1. ENERGY STAR® at <http://www.energystar.gov/products>; and

2. FEMP at [http://www1.eere.energy.gov/femp/procurement/eep\\_requirements.html](http://www1.eere.energy.gov/femp/procurement/eep_requirements.html).

## **12. BUY AMERICAN—CONSTRUCTION MATERIALS**

A. Definitions. As used in this clause—

1. “Commercially available off-the-shelf (COTS) item”—

a. Means any item of supply (including construction material) that is—

i. A commercial item (as defined in paragraph (1) of the definition at FAR [2.101](#));

ii. Sold in substantial quantities in the commercial marketplace; and

iii. Offered to the Government, under a contract or subcontract at any tier, without modification, in the same form in which it is sold in the commercial marketplace; and

b. Does not include bulk cargo, as defined in [46 U.S.C. 40102\(4\)](#), such as agricultural products and petroleum products.

2. “Component” means an article, material, or supply incorporated directly into a construction material.

3. “Construction material” means an article, material, or supply brought to the construction site by the Contractor or a subcontractor for incorporation into the building or work. The term also includes an item brought to the site preassembled from articles, materials, or supplies. However, emergency life safety systems, such as emergency lighting, fire alarm, and audio evacuation systems, that are discrete systems incorporated into a public building or work and that are produced as complete systems, are evaluated as a single and distinct construction material regardless of when or how the individual parts or components of those systems are delivered to the construction site. Materials purchased directly by the Government are supplies, not construction material.



4. “Cost of components” means—
  - a. For components purchased by the Contractor, the acquisition cost, including transportation costs to the place of incorporation into the construction material (whether or not such costs are paid to a domestic firm), and any applicable duty (whether or not a duty-free entry certificate is issued); or
  - b. For components manufactured by the Contractor, all costs associated with the manufacture of the component, including transportation costs as described in paragraph (1) of this definition, plus allocable overhead costs, but excluding profit. Cost of components does not include any costs associated with the manufacture of the construction material.
  
5. “Domestic construction material” means—
  - a. An unmanufactured construction material mined or produced in the United States;
  - b. A construction material manufactured in the United States, if—
    - i. The cost of its components mined, produced, or manufactured in the United States exceeds 50 percent of the cost of all its components. Components of foreign origin of the same class or kind for which nonavailability determinations have been made are treated as domestic.
    - b. The construction material is a COTS item.
  
6. “Foreign construction material” means a construction material other than a domestic construction material.
  
7. “United States” means the 50 States, the District of Columbia, and outlying areas.
  - a. Domestic preference.
    - i. This clause implements [41 U.S.C. chapter 83](#), Buy American, by providing a preference for domestic construction material. In accordance with [41 U.S.C. 1907](#), the component test of the Buy American statute is waived for construction material that is a COTS item. (See FAR [12.505\(a\)\(2\)](#)). The Contractor shall use only domestic construction material in performing this contract, except as provided in paragraphs (b)(2) and (b)(3) of this clause.
    - ii. This requirement does not apply to information technology that is a commercial item or to the construction materials or components listed by the Government as follows:
  - b. The Contracting Officer may add other foreign construction material to the list in paragraph (b)(2) of this clause if the Government determines that—
    - i. The cost of domestic construction material would be unreasonable. The cost of a particular domestic construction material subject to the requirements of the Buy American statute is unreasonable when the cost



of such material exceeds the cost of foreign material by more than 6 percent;

ii. The application of the restriction of the Buy American statute to a particular construction material would be impracticable or inconsistent with the public interest; or

iii. The construction material is not mined, produced, or manufactured in the United States in sufficient and reasonably available commercial quantities of a satisfactory quality.

8. Request for determination of inapplicability of the Buy American statute.

a. Any Contractor request to use foreign construction material in accordance with paragraph (b)(3) of this clause shall include adequate information for Government evaluation of the request, including—

i. A description of the foreign and domestic construction materials

ii. Unit of measure

iii. Quantity

iv. Price

v. Time of delivery or availability

vi. Location of the construction project

vii. Name and address of the proposed supplier

viii. A detailed justification of the reason for use of foreign construction materials cited in accordance with paragraph (b)(3) of this clause.

b. A request based on unreasonable cost shall include a reasonable survey of the market and a completed price comparison table in the format in paragraph (d) of this clause.

(iii) The price of construction material shall include all delivery costs to the construction site and any applicable duty (whether or not a duty-free certificate may be issued).

(iv) Any Contractor request for a determination submitted after contract award shall explain why the Contractor could not reasonably foresee the need for such determination and could not have requested the determination before contract award. If the Contractor does not submit a satisfactory explanation, the Contracting Officer need not make a determination.

(2) If the Government determines after contract award that an exception to the Buy American statute applies and the Contracting Officer and the Contractor negotiate adequate consideration, the Contracting Officer will modify the contract to allow use of the foreign construction material. However, when the basis for the exception is the unreasonable price of a domestic construction material, adequate consideration is not less than the differential established in paragraph (b)(3)(i) of this clause.



(3) Unless the Government determines that an exception to the Buy American statute applies, use of foreign construction material is noncompliant with the Buy American statute.

(d) Data. To permit evaluation of requests under paragraph (c) of this clause based on unreasonable cost, the Contractor shall include the following information and any applicable supporting data based on the survey of suppliers:

**FOREIGN AND DOMESTIC CONSTRUCTION MATERIALS PRICE COMPARISON**

Construction Material Description	Unit of Measure	Quantity	Price (Dollars)*
Item 1:			
Foreign construction material	_____	_____	_____
Domestic construction material	_____	_____	_____
Item 2:			
Foreign construction material	_____	_____	_____
Domestic construction material	_____	_____	_____

[List name, address, telephone number, and contact for suppliers surveyed. Attach copy of response; if oral, attach summary.]

[Include other applicable supporting information.]

[\* Include all delivery costs to the construction site and any applicable duty (whether or not a duty-free entry certificate is issued).]

**13. INFRASTRUCTURE INVESTMENT AND JOBS ACT, BUILD AMERICA, BUY AMERICA**

**THIS SECTION ONLY APPLIES TO PROJECTS THAT HAVE A TOTAL COST OF \$250,000 OR MORE AND THAT INCLUDE THE USE OF IRON OR STEEL.**

Recipients of an award of Federal financial assistance from a program for infrastructure are hereby notified that none of the funds provided under this Agreement may be used for a project for infrastructure unless:

A. All iron and steel used in the PROJECT are produced in the United States--this means all manufacturing processes, from the initial melting stage through the application of coatings, occurred in the United States.

B. All manufactured products used in the PROJECT are produced in the United States—this means the manufactured product was manufactured in the United States; and the cost of the components of the manufactured product that are mined, produced, or manufactured in the United States is greater than 55 percent of the total cost of all components of the manufactured product, unless another standard for determining the minimum amount of domestic content of the manufactured product has been established under applicable law or regulation.



C. All construction materials (excludes cement and cementitious materials, aggregates such as stone, sand, or gravel, or aggregate binding agents or additives) are manufactured in the United States—this means that all manufacturing processes for the construction material occurred in the United States.

D. The Buy America preference only applies to articles, materials, and supplies that are consumed in, incorporated into, or affixed to an infrastructure project. As such, it does not apply to tools, equipment, and supplies, such as temporary scaffolding, brought to the construction site and removed at or before the completion of the infrastructure project. Nor does a Buy America preference apply to equipment and furnishings, such as movable chairs, desks, and portable computer equipment, that are used at or within the finished infrastructure project but are not an integral part of the structure or permanently affixed to the infrastructure project.

E. Definitions:

“Construction materials” includes an article, material, or supply—other than an item of primarily iron or steel; a manufactured product; cement and cementitious materials; aggregates such as stone, sand, or gravel; or aggregate binding agents or additives 46—that is or consists primarily of:

1. Non-ferrous metals
2. Plastic and polymer-based products (including polyvinyl/chloride, composite building materials, and polymers used in fiber optic cables)
3. Glass (including optic glass)
4. Lumber; or drywall





## SECTION V – EXHIBITS

### 5.0 EXHIBITS

Exhibit 1	Qualification Documents
Exhibit 2	Sample Contract
Exhibit 3	Evaluation Scoresheet
Exhibit 4	Federal Forms



**EXHIBIT 1 QUALIFICATIONS DOCUMENTS**

**FOLLOWS THIS PAGE**



**SOLICITATION QUALIFICATIONS DOCUMENTS**

Please complete all sections of this document including the Solicitation Certification, Representations and Certifications, Qualification Statement, Exceptions, Minimum Insurance Requirements, and Signature Page.

Please submit all completed documents with your bid/ proposal and sign the Minimum Insurance Requirements and Signature Page.

Solicitation:

Solicitation Number:

Firm Name:

Date:

Address:

Federal Tax ID #:

Tax Classification:

Sole Proprietorship

Partnership

C Corporation

S Corporation

LLC

Nonprofit

DUNS Number:

**OFFEROR REPRESENTATIVE**

Offeror has appointed the following as the offeror's representative and contact for all questions or clarifications in regard to this offeror.

Name:

Telephone:

E-mail:



## SOLICITATION CERTIFICATION

### PLACE OF BUSINESS

Company's Principal Place of Business

Does Offeror Have an established office or facility in Colorado Springs?    YES            NO

If Yes, Indicate address below if different from principal place of business.

Year Facility Was Established

Percent of Work to be performed from principal place of business.

Percent of Work to be performed from Colorado Springs Facility

### INSURANCE

Indicate your ability to provide a certificate of insurance evidencing the required coverage types and limits specified in Minimum Insurance Requirements Exhibit. (The certificate of insurance must reflect the City of Colorado Springs as an Additional Insured, as applicable.)

*Initial Here*

Indicate your Ability to Comply with the following requirements:

The City shall be added as an Additional Insured to all liability policies

YES

NO



Your property and liability insurance company is licensed to do business in Colorado

YES

NO

Your property and liability insurance company has an AM best rating of not less than B+ and/or

YES

NO

Worker's Compensation Insurance is carried for all employees and covers work done in Colorado.

YES

NO

Provide the name of your property and liability insurance company here:

## **FINANCIAL STATEMENTS**

Current Financial Statements are not required for this solicitation.

Current Financial Statements are required for this solicitation. Please include financial statements as a separate document with your proposal.

*Initial Here*

## **COMPLETED PROPOSAL**

Provide the completed and signed proposal. (Proposals must be identified as specified in this RFP document). All required Exhibits are attached.

*Initial Here*



## **ACKNOWLEDGE ADDENDUM**

Offeror hereby acknowledges receipt of the following amendments, if applicable Offeror agrees that it is bound by all Amendments identified herein.

Addendum #1 *Initial Here* Dated:

Addendum #2 *Initial Here* Dated:

Addendum #3 *Initial Here* Dated:

Additional Addendum, if issued *Initial Here* Dated:



## REPRESENTATIONS AND CERTIFICATIONS

### 1. INSURANCE REQUIREMENTS

Offeror shall comply with all insurance requirements and will submit the Insurance Certificates prior to performance start date. If limits are different from the stated amounts, Offeror shall explain variance. Certain endorsements and “additionally insured” statements may require further clarification and specific statements on a project specific basis and should have been described in the Offeror’s proposal.

*Initial Here #1*

### 2. ETHICS VIOLATIONS

- a) The Offeror shall have in place and follow reasonable procedures designed to prevent and detect possible violations described in this clause in its own operations and direct business relationships.
- b) Offeror certifies the Offeror has not violated or caused any person to violate, and shall not violate or cause any person to violate, the City’s Code of Ethics contained in Article 3, of Chapter 1 of the City Code and in the City’s Procurement Rules and Regulations
- c) When the Offeror has reasonable grounds to believe that a violation described in this clause may have occurred, the Offeror shall promptly report the possible violation to the City Contracts Specialist in writing.
- d) The Offeror must disclose with the signing of this proposal, the name of any officer, director, or agent who is also an employee of the City and any City employee who owns, directly or indirectly, an interest of ten percent (10%) or more in the Offeror’s firm or any of its branches.
- e) In addition, the Offeror must report any conflict or apparent conflict, current or discovered during the performance of the Contract, to the City Contracts Specialist.
- f) The Offeror shall not engage in providing gifts, meals or other amenities to City employees. The right of the Offeror to proceed may be terminated by written notice issued by City Contracts Specialist if Offeror offered or gave a gratuity to an officer, official, or employee of the City and intended by the gratuity to obtain a contract or favorable treatment under a contract.
- g) The Offeror shall cooperate fully with the City or any agency investigating a possible violation on behalf of the City. If any violation is determined, the Offeror will properly compensate the City.
- h) The Offeror agrees to incorporate the substance of this clause (after substituting “Contractor” for “Offeror”) in all subcontracts under this offer.

*Initial Here #2*



### **3. COOPERATION WITH OTHER CONTRACTORS**

Other City activities/contracts may be in progress or start during the performance of this contract. The Offeror shall coordinate the work harmoniously with the other contractors or City personnel, if applicable.

*Initial Here #3*

### **4. INTERNET USE**

Should the Offeror require access to City Internet resources in the performance of this requirement, a "Contractor's Internet Use Agreement" form must be separately signed by each individual having access to the City Network. The completed Contractor's Internet Use Agreement will be maintained with this agreement. Inappropriate use of the City Network will be grounds for immediate termination of any awarded contact.

*Initial Here #4*

### **5. LITIGATION**

If awarded a contract, Offeror shall notify the City within five (5) calendar days after being served with a summons, complaint, or other pleading in any matter which has been filed in any federal or state court or administrative agency. The Offeror shall deliver copies of such document(s) to the City's Procurement Services Manager. The term "litigation" includes an assignment for the benefit of creditors, and filings of bankruptcy, reorganization and/or foreclosure.

*Initial Here #5*

### **6. CONTRACTOR'S REGISTRATION INFORMATION**

Offeror's firm verifies and states that they are (check all that apply):

Large Business (i.e. do not qualify as a small business or non-profit)

Nonprofit

Small Business

Minority Owned Business/Small Disadvantaged Business

Woman Owned Business





Veteran Owned Business

Service-Disabled Veteran Owned Business

HUBZone Business

Note: The City accepts self-certification for these categories in accordance with Small Business Administration (SBA) standards. The SBA size standards are found on the SBA website <https://www.sba.gov/content/am-i-small-business-concern>.

*Initial Here #6*

## **7. CONTRACTOR PERSONNEL**

- a) The Offeror shall appoint one of its key personnel as the “Authorized Representative” who shall have the power and authority to interface with the City and represent the Offeror in all administrative matters concerning this proposal and any awarded contract, including without limitation such administrative matters as correction of problems modifications, and reduction of costs.
- b) The Authorized Representative shall be the person identified in the Offeror’s proposal, unless the Offeror provides written notice to the City naming another person to serve as its Authorized Representative. Communications received by the City Contracts Specialist from the Authorized Representative shall be deemed to have been received from the Offeror.

Name:

Telephone:

E-mail:

*Initial Here #7*

## **8. OFFEROR’S CERTIFICATION**

The undersigned hereby affirms that:

- a) He/She is a duly authorized agent of the Offeror;
- b) He/She has read and agrees to the City’s standard terms and conditions attached.
- c) The offer is presented in full compliance with the collusive prohibitions of the City of Colorado Springs. The Offeror certifies that no employee of its firm has discussed, or



compared the offer with any other offeror or City employee and has not colluded with any other offeror or City employee.

- d) The Offeror certifies that it has checked all of its figures, and understands that the City will not be responsible for any errors or omissions on the part of the Offeror in preparing its proposal.
- e) By submitting an offer the Offeror certifies that it has complied and will comply with all requirements of local, state, and federal laws, and that no legal requirements have been or will be violated in making or accepting this solicitation.

I hereby certify that I am submitting the proposal based on my company's capabilities to provide quality products and/or services on time.

*Initial Here #8*

**9. OFFEROR CERTIFICATION REGARDING DEBARMENT, SUSPENSION, PROPOSED DEBARMENT, AND OTHER RESPONSIBILITY MATTERS:**

- 1. The Offeror certifies to the best of its knowledge and belief, that (i) the Offeror and/or any of its Principals

Are                      Are Not

Presently debarred, suspended, proposed for debarment, or declared ineligible for the award of contracts by any Federal agency.

Have                      Have Not

Within a three year period preceding this offer, been convicted of or had a civil judgment rendered against them for: commission of fraud or a criminal offense in connection with obtaining, attempting to obtain, or performing a public (federal, state, local) contract or subcontract; violation of Federal or state antitrust statutes relation to the submission of offers; or commission of embezzlement, theft, forgery, bribery, falsification or destruction of records, making false statement, tax evasion, or receiving stolen property; and

Are                      Are Not

presently indicated for, or otherwise criminally or civilly charged by a governmental entity with commission of any of the offenses enumerated in any paragraphs above.

- 2. The Offeror shall provide immediate written notice to the City Contracts Specialist if, at any time prior to contract award, the Offeror learns that its certification was erroneous when submitted or has become erroneous by reasons of changed circumstances.
- 3. The certification in paragraph 1. above, is a material representation of fact upon which reliance was placed when making award. If it is later determined that the Offeror knowingly rendered an erroneous certification, in addition to other remedies available to the City, the



City Contracts Specialist may terminate the contract resulting from this solicitation for default. Termination for default may result in additional charges being levied for the costs incurred by the City to initiate activities to replace the awarded Contractor.

Initial Here #9

#### **10. ACCEPTANCE OF CITY CONTRACTS SPECIALIST'S SOLE AUTHORITY FOR CHANGES**

Unless otherwise specified in the Contract, the Offeror hereby agrees that any changes to the scope of work, subsequent to the original contract signing, shall be generated in writing and an approval signature shall be obtained from the City Contracts Specialist prior to additional work performance.

*Initial Here #10*

#### **11. CITY CONTRACTOR SAFETY PROGRAM**

The Offeror hereby agrees to adhere to a worker safety program for contractor employees on a City job site or location. By initialing below, the Offeror has reviewed the information and will abide by the City Policy which is available for review:

<https://coloradosprings.gov/finance/page/procurement-regulations-and-documents>

*Initial Here #11*

#### **12. ACCEPTANCE OF CITY ENVIRONMENTALLY PREFERRED PURCHASING (EPP) POLICY**

The City of Colorado Springs is committed to buying more environmentally preferable goods and services, as long as they meet performance needs, are available within a reasonable time and at a reasonable cost. The Offeror hereby acknowledges review of this policy by initialing below.

<https://coloradosprings.gov/finance/page/procurement-regulations-and-documents>

*Initial Here #12*



### **13. FRAUD, WASTE, AND ABUSE**

Everyone has a duty to report any suspected unlawful act impacting the City of Colorado Springs operations and its enterprises. Anyone who becomes aware of the existence or apparent existence of fraud, waste, and abuse in City of Colorado Springs is encouraged to report such matters to the City Auditor's Office in writing or on the telephone hotline 385-2387 (ADTR). Written correspondence can be mailed to:

City Auditor

P.O. Box 2241

Colorado Springs CO 80901

Or via email [FraudHotline@ColoradoSprings.gov](mailto:FraudHotline@ColoradoSprings.gov). Any of these mechanisms allow for anonymous reporting. For more information, please go to the website <https://coloradosprings.gov/cityfraud>.

*Initial Here #13*



## **QUALIFICATION STATEMENT**

This statement will provide information which will enable the City to evaluate the qualifications of your firm and staff with regard to the requirements of this solicitation. Please complete this form in its entirety. If a request in the Qualification Statement is contained in the proposal, indicate the section in the proposal where that information can be found.

### **1. TYPE OF LICENSE(S) HELD**

### **2. TYPE OF SERVICE TO BE PROVIDED FOR THIS SOLICITATION**

### **3. NUMBER OF YEARS IN BUSINESS**

### **4. FIRM HISTORY & STAFF QUALIFICATIONS**

In your proposal provide a brief history of your firm, staff size, and experience. Submit a resume for the project manager and each key personnel assigned to this project.

### **5. WHAT OTHER NAME(S) HAS YOUR COMPANY OPERATED UNDER**

My Firm has not operated under any other names

### **6. HAVE YOU OR YOUR FIRM EVER FAILED TO COMPLETE ANY WORK AWARDED TO YOU?**

Yes                      No

If Yes, Please Explain



**7. HAS ANY OFFICER OF PARTNER OF YOUR ORGANIZATION EVER BEEN AN OFFICER OR PARTNER OF ANOTHER ORGANIZATION THAT FIALED TO COMPLETE A CONTRACT WITHIN THE LAST FIVE (5) YEARS?**

Yes                      No

If Yes, Please Explain

**8. HAS YOUR FIRM OR ANY PARTNERS OR OFFICERS EVER BEEN INVOLVED IN ANY BANKRUPTCY ACTION?**

Yes                      No

If Yes, Please Explain

**9. ARE YOU PRESENTLY INVOLVED IN ANY LITIGATION WITH ANY GOVERNMENT AGENCY?**

Yes                      No

If Yes, Please Explain Type, Kind, Plaintiff, Defendant, etc. and state the current status:

**10. BANK REFERENCE**

Bank Name:

Address:

Contact:

Phone #:

E-mail:



## 11. SIMILAR PROJECTS

List Three similar projects (local or state-wide) from the last five (5) years. Include the location of the project, size of project (contract amount), contract name and information. NOTE: Detailed information on these projects may also be requested in the solicitation package

Indicate here if this information is provided within your proposal and identify where in the proposal it is located.

### 1. Company:

Location of Project:

Contract Amount:

Contract Period of Performance:

Company Representative:

Representative's Title:

Representative's Address:

Representative's Phone #:

Representative's E-mail:

Brief Description of service/goods provided and how your firm was successful carrying out the scope of work of the contract.

### 2. Company:

Location of Project:

Contract Amount:

Contract Period of Performance:

Company Representative:



Representative's Title:

Representative's Address:

Representative's Phone #:

Representative's E-mail:

Brief Description of service/goods provided and how your firm was successful carrying out the scope of work of the contract.

3. Company:

Location of Project:

Contract Amount:

Contract Period of Performance:

Company Representative:

Representative's Title:

Representative's Address:

Representative's Phone #:

Representative's E-mail:

Brief Description of service/goods provided and how your firm was successful carrying out the scope of work of the contract.





## 12. SIMILAR PROJECTS CURRENTLY UNDER CONTRACT

list three projects currently under contract and in progress (local or state-wide) from the last five (5) years. Include the location of the project, size of project (contract amount), contract name and information. NOTE: Detailed information on these projects may also be requested in the solicitation package

Indicate here if this information is provided within your proposal and Identify where in the proposal it is located.

1. Company:

Location of Project:

Contract Amount:

Contract Period of Performance:

Company Representative:

Representative's Title:

Representative's Address:

Representative's Phone #:

Representative's E-mail:

Brief Description of service/goods provided.

2. Company:

Location of Project:

Contract Amount:

Contract Period of Performance:

Company Representative:



Representative's Title:

Representative's Address:

Representative's Phone #:

Representative's E-mail:

Brief Description of service/goods provided.

3. Company:

Location of Project:

Contract Amount:

Contract Period of Performance:

Company Representative:

Representative's Title:

Representative's Address:

Representative's Phone #:

Representative's E-mail:

Brief Description of service/goods provided.



### **13. ADDITIONAL QUALIFICATION REQUIREMENTS**

There are no additional qualification requirements for this solicitation.

There are additional qualification requirements as follows:



## EXCEPTIONS

Please Indicate below if there are any exceptions taken to any of the terms, conditions, or specifications of these proposal documents or contract.

If there are exceptions taken to any of the terms, conditions, or specifications of the proposal document or contract, they must be clearly stated on an additional document attached to this exhibit and returned with your proposal.

**NOTE: All potential Offerors are hereby advised that exceptions taken may be considered during the evaluation phase which may affect the final scoring of proposals. Offerors stipulating that the City must use their contract or agreement may be determined non-responsive and their Proposal determined unacceptable.**

Please indicate below:

My Firm has no exceptions.

My Firm does have exceptions. (Attach Exceptions to this exhibit)



## MINIMUM INSURANCE REQUIREMENTS

The following listed minimum insurance requirements shall be carried by all contractors and consultants unless otherwise specified in the City's solicitation package, Special Provisions or Standard Specifications.

- Commercial General Liability for limits not less than \$1,000,000 combined single limit with \$2,000,000 aggregate for bodily injury and property damage for each occurrence. Coverage shall include blanket contractual, broad form property damage, products and completed operations.
- Workers' Compensation and Employers Liability as required by statute. Employers Liability coverage is to be carried for a minimum limit of \$1,000,000.
- Automobile Liability covering any auto (including owned, hired, and non-owned autos) with a minimum of \$1,000,000 each accident combined single limit.

Except for workers' compensation and employer's liability insurance and Professional Liability, the City of Colorado Springs must be named as an additional insured. Certificates of Insurance must be submitted before commencing the work and provide 30 days' notice prior to any cancellation, non-renewal, or material changes to policies required under the contract.

Name of Company

Signature

Date



## **SIGNATURE PAGE**

By signing below, the Offeror certifies that no person or firm other than the Offeror or as otherwise indicated has any interest whatsoever in this offer or any Contract that may be entered into as a result of this offer and that in all respects the offer is legal and firm, submitted in good faith without collusion or fraud.

The undersigned additionally declares that it has carefully examined the Bid/Proposal information and the complete Solicitation prior to submitting a Bid / Proposal. The Offeror's signature will be considered the Offeror's acknowledgement of understanding and ability to comply with all items in the solicitation.

The undersigned acknowledges and understands the terms, conditions, Specifications and all Requirements contained and/or referenced and are legally authorized by the Offeror to make the above statements or representations.

Signature

Name (Printed)

Company Name

Title

Date



**EXHIBIT 2    SAMPLE CONTRACT**  
**CONSTRUCTION CONTRACT**

Contract Number:		Project Name/Title	
Vendor/Contractor			
Contact Name:		Telephone:	
Email Address:			
Address:			
Federal Tax ID #		Please check one:	<input type="checkbox"/> Corporation <input type="checkbox"/> Individual <input type="checkbox"/> Partnership
City Contracting Specialist		City Dept Rep	
NOT TO EXCEED Contract Amount:		City Account #	
Contract Type:	Fixed Unit Price	Period of Performance:	

**1. INTRODUCTION**

THIS Fixed Unit Price CONTRACT ("Contract") is made and entered into this XXX day of XXX, 2022 by and between the City of Colorado Springs, a Colorado municipal corporation and home rule city, in the County of El Paso, State of Colorado, (the "City"), and \_\_\_\_\_ (the "Contractor").

THE CITY AND THE CONTRACTOR HEREBY AGREE AS FOLLOWS:

The City has heretofore prepared the necessary Contract Documents for the following Activity: XXXX.

The Contractor did on the XXX day of XXX, 2022 submit to the City the Contractor's written offer and proposal to do the work therein described under the terms and conditions therein set forth and furnish all materials, supplies, labor, services, transportation, tools, equipment, and parts for said work in strict conformity with the accompanying Contract Documents, which are attached hereto and incorporated herein by this reference, including the following:

1. This Contract
2. Schedule A – Price Sheet
3. Schedule B – General Construction Terms and Conditions
4. Schedule C – Special Contract Terms and Conditions
5. Schedule D – General Specifications
6. Schedule E – Special and Technical Specifications
7. Schedule F – Scope of Work
8. Exhibit 1 – Performance, Labor and Material Payment, and Maintenance Bonds
9. Exhibit 2 – Minimum Insurance Requirements



## 2. COMPENSATION/CONSIDERATION

THIS FIXED UNIT PRICE CONTRACT is established at the Not to Exceed amount of \$xxxxxxx.

Subject to the terms and conditions of the Contract Documents, Contractor agrees to furnish all materials and to perform all work as set forth in its proposal and as required by the Contract Documents.

All pricing is in accordance with the fixed unit prices found in Schedule A, as proposed by the Contractor. Payment made for actual quantities as set forth in Schedule B, General Construction Terms and Conditions. At no time shall the total obligation of the City exceed the not to exceed amount of this Contract.

## 3. TERM OF CONTRACT

Contractor will start work promptly after the Notice to Proceed and continue to work diligently until completed. The Contractor shall complete all work on an as ordered basis throughout the Contract period which is **the date of Notice to Proceed through April 30, 2022** ("Period of Performance") as per the specifications and drawings. The Contractor shall provide a two-year guarantee on all work performed under this Contract after the job has been completed and accepted.

## 4. INSURANCE

The Contractor shall provide and maintain acceptable Insurance Policy(s) consistent with the Minimum Insurance Requirements attached as Exhibit 2, which includes Property, Liability, and as otherwise listed in Exhibit 2. The City of Colorado Springs shall be reflected as an additional insured on the Property and Liability policy(s).

Further, Contractor understands and agrees that Contractor shall have no right of coverage under any existing or future City comprehensive, self, or personal injury policies. Contractor shall provide insurance coverage for and on behalf of Contract that will sufficiently protect Contractor, or Contractor's agents, employees, servants or other personnel, in connection with the services which are to be provided by Contractor pursuant to this Contract, including protection from claims for bodily injury, death, property damage, and lost income. Contractor shall provide worker's compensation insurance coverage for Contractor and all Contractor personnel. Contractor shall file applicable insurance certificates with the City and shall also provide additional insurance as indicated in this Contract. ***A CURRENT CERTIFICATE OF INSURANCE IS REQUIRED PRIOR TO COMMENCEMENT OF SERVICES LISTING THE CITY AS ADDITIONALLY INSURED.***

## 5. RESPONSIBILITY OF THE CONTRACTOR

- A. The Contractor shall be responsible for the professional quality, technical accuracy, and the coordination of all Scope of Work services furnished by the Contractor under this Contract. The Contractor shall, without additional compensation, correct or revise any errors or deficiencies in services provided under this Contract to the satisfaction of the City.
- B. The City's review, approval of, acceptance of, or payment for the services required under this Contract shall not be construed to operate as a waiver of any rights under this Contract or of any cause of action arising out of the performance of this Contract, and the Contractor shall





be and remain liable to the City for any and all damages to the City caused by the Contractor's negligent performance of any of the services furnished under this Contract.

- C. The rights and remedies of the City provided for under this Contract are in addition to any other rights and remedies provided by law.
- D. If the Contractor is comprised of more than one legal entity, each such entity shall be jointly and severally liable hereunder.

## **6. WORK OVERSIGHT**

- A. The extent and character of the work to be done by the Contractor shall be subject to the general approval of the City's delegated Project Manager.
- B. If any of the work or services being performed does not conform with Contract requirements, the City may require the Contractor to perform the work or services again in conformity with Contract requirements, at no increase in Contract amount. When defects in work or services cannot be corrected by re-performance, the City may (1) require the Contractor to take necessary action to ensure that future performance conforms to Contract requirements and (2) reduce the Contract price to reflect the reduced value of the work or services performed.
- C. If the Contractor fails to promptly perform the defective work or services again or to take the necessary action to ensure future performance is in conformity with Contract requirements, the City may (1) by Contract or otherwise, perform the services and charge to the Contractor any cost incurred by the City that is directly related to the performance of such work or service or (2) terminate the Contract for breach of contract.

## **7. SUBCONTRACTORS, ASSOCIATES, AND OTHER CONTRACTORS**

- A. Any subcontractor, outside associates, or other contractors used by the Contractor in connection with Contractor's work under this Contract shall be limited to individuals or firms that are specifically identified by the Contractor in the Contractor's proposal and agreed to by the City. The Contractor shall obtain the City's Project Manager's written consent before making any substitution of these subcontractors, associates, or other contractors.
- B. The Contractor shall include a flow down clause in all of its subcontracts, agreements with outside associates, and agreements with other contractors. The flow down clause shall cause all of the terms and conditions of this Contract, including all of the applicable parts of the Contract Documents, to be incorporated into all subcontracts, agreements with outside associates, and agreements with other contractors. The flow down clause shall provide clearly that there is no privity of contract between the City and the Contractor's subcontractors, outside associates, and other contractors.

## **8. KEY PERSONNEL**

The key personnel listed in the proposal and/or below will be the individuals used in the performance of the work. If any of the listed key personnel leave employment or are otherwise not utilized in the performance of the work, approval to substitute must be obtained by the



Contractor from the City's Project Manager. Any substitute shall have the same or a higher standard of qualifications that the key personnel possessed at the time of Contract award.

## **9. START AND CONTINUANCE OF WORK**

It is further agreed that the Contractor will start work promptly and continue to work diligently until this Contract is completed.

## **10. APPROPRIATION OF FUNDS**

This Contract is expressly made subject to the limitations of the Colorado Constitution and Section 7-60 of the Charter of the City of Colorado Springs. Nothing herein shall constitute, nor be deemed to constitute, the creation of a debt or multi-year fiscal obligation or an obligation of future appropriations by the City Council of Colorado Springs, contrary to Article X, § 20, Colo. Const., or any other constitutional, statutory, or charter debt limitation. Notwithstanding any other provision of this Contract, with respect to any financial obligation of the City which may arise under this Agreement in any fiscal year after the year of execution, in the event the budget or other means of appropriation for any such year fails to provide funds in sufficient amounts to discharge such obligation, such failure (i) shall act to terminate this Contract at such time as the then-existing and available appropriations are depleted, and (ii) neither such failure nor termination shall constitute a default or breach of this Contract, including any sub-agreement, attachment, schedule, or exhibit thereto, by the City. As used herein, the term "appropriation" shall mean and include the due adoption of an appropriation ordinance and budget and the approval of a Budget Detail Report (Resource Allocations) which contains an allocation of sufficient funds for the performance of fiscal obligations arising under this Contract.

## **11. CHANGES**

The Contractor and the City agree and acknowledge as a part of this Contract that no change order or other form or order or directive may be issued by the City which requires additional compensable work to be performed, which work causes the aggregate amount payable under the Contract to exceed the amount appropriated for this Contract as listed above, unless the Contractor has been given a written assurance by the City that lawful appropriations to cover the costs of the additional work have been made or unless such work is covered under a remedy-granting provision of this Contract. The Contractor and the City further agree and acknowledge as a part of this Contract that no change order or other form or order or directive which requires additional compensable work to be performed under this Contract shall be issued by the City unless funds are available to pay such additional costs, and, regardless of any remedy-granting provision included within this Contract, the Contractor shall not be entitled to any additional compensation for any change which increases or decreases the Contract completion date, or for any additional compensable work performed under this Contract, and expressly waives any rights to additional compensation, whether by law or equity, unless, prior to commencing the additional work, the Contractor is given a written change order describing the change in Contract completion date or the additional compensable work to be performed, and setting forth the amount of compensation to be paid, and such change order is signed by the authorized City representative, as defined below. The amount of compensation to be paid, if any, shall be deemed to cover any and all additional, direct, indirect or other cost or expense or profit of the Contractor whatsoever. It is the Contractor's sole responsibility to know, determine, and ascertain the authority of the City representative signing any change order under this Contract.



No change, amendment, or modification to this Contract shall be valid unless duly approved and issued in writing by the City of Colorado Springs Procurement Services Division. The City shall not be liable for any costs incurred by the Contractor resulting from work performed for changes not issued in writing by the City of Colorado Springs Procurement Services Division.

The following personnel are authorized to sign changes, amendments, or modifications to this Contract.

The Department Manager: up to \$149,999.99

The City of Colorado Springs Deputy Chief of Staff: \$150,000.00 to \$499,999.99

The City of Colorado Springs Chief of Staff: \$500,000.00 to \$1,999,999.99

The Mayor of Colorado Springs: Unlimited

## **12. ECONOMIC PRICE ADJUSTMENT**

- A. The Contractor shall notify the City of Colorado Springs Procurement Services Division if, at any time during contract performance, the rate of pay for labor or the unit prices for material shown in Schedule A experiences a significant increase. A change in price shall be considered significant when the unit price of an item increases by 10% from the execution date of this Contract. The Contractor shall furnish notice of this increase within 60 days after the increase, or within any additional period that the City Procurement Services Division may approve in writing, but not later than the date of final payment under this Contract. The notice shall include the Contractor's proposal for an adjustment in the Contract unit prices to be negotiated under paragraph (b) of this clause, and shall include, in the form required by the City Procurement Services Division, supporting data explaining the cause, effective date, and amount of the increase and the amount of the Contractor's adjustment proposal.
- B. Promptly after the City Procurement Services Division receives the notice and data under paragraph (a) of this clause, the City Procurement Services Division and the Contractor shall negotiate a price adjustment in the contract unit prices and its effective date. However, the City Procurement Services Division may postpone the negotiations until an accumulation of increases in the labor rates (including fringe benefits) and unit prices of material shown in Schedule A results in an adjustment allowable under paragraph (c)(3) of this clause. The City Procurement Services Division shall modify this contract (1) to include the price adjustment and its effective date and (2) to revise the labor rates (including fringe benefits) or unit prices of material as shown in Schedule A to reflect the increases resulting from the adjustment. The Contractor shall continue performance at current rates pending agreement on, or determination of, any adjustment and its effective date.
- C. Any price adjustment under this clause is subject to the following limitations:
  1. Any adjustment shall be limited to the effect on unit prices of the increases in the rates of pay for labor (including fringe benefits) or unit prices for material shown in Schedule A. There shall be no adjustment for:
    - (i) Supplies or services for which the production cost is not affected by such changes;
    - (ii) Changes in rates or unit prices other than those shown in Schedule A; or
    - (iii) Changes in the quantities of labor or material used from those shown in Schedule A for each item.



2. No upward adjustment shall apply to supplies or services that are required to be delivered or performed before the effective date of the adjustment, unless the Contractor's failure to deliver or perform according to the delivery schedule results from causes beyond the Contractor's control and without its fault or negligence, within the meaning of the Default clause.
3. There shall be no adjustment for any change in rates of pay for labor (including fringe benefits) or unit prices for material which would not result in a net change of at least 3 percent of the then-current total contract price. This limitation shall not apply, however, if, after final delivery of all line items, either party requests an adjustment under paragraph (b) of this clause.
4. The aggregate of the increases in any contract unit price made under this clause shall not exceed 10 percent of the original unit price.

### **13. ASSIGNMENT**

No assignment or transfer by the Contractor of this Contract or any part thereof or of the funds to be received thereunder by the Contractor will be recognized unless such assignment has had the prior written approval of the City and the surety has been given due notice of such assignment. Such written approval by the City shall not relieve the Contractor of the obligations under the terms of this Contract. In addition to the usual recitals in assignment contracts, the following language must be included in the assignment:

It is agreed that the funds to be paid to the assignee under this assignment are subject to a prior lien for services rendered or materials supplied for the performance of the work called for in said contract in favor of all persons, firms, or corporations rendering such services or supplying such materials.

### **14. CHOICE OF LAW**

This Contract is subject to and shall be interpreted under the law of the State of Colorado, and the Charter, City Code, Ordinances, Rules and Regulations of the City of Colorado Springs, Colorado, a Colorado home rule city. Court venue and jurisdiction shall be exclusively in the Colorado District Court for El Paso County, Colorado. The Parties agree that the place of performance for this Contract is deemed to be in the City of Colorado Springs, El Paso County, State of Colorado. The Contractor shall ensure that the Contractor and the Contractor's employees, agents, officers and subcontractors are familiar with, and comply with, applicable Federal, State, and Local laws and regulations as now written or hereafter amended.

### **15. WORKERS' COMPENSATION INSURANCE**

Contractor shall take out and maintain during the Period of Performance, Colorado Worker's Compensation Insurance for the Contractor and all employees of the Contractor. If any service is sublet by the Contractor, the Contractor shall require the subcontractor to provide the same coverage for the subcontractor and subcontractor's employees. Workers' Compensation Insurance shall include occupational disease provisions covering any obligations of the Contractor in accord with the provisions of the Workers' Compensation Act of Colorado.

### **16. INDEMNIFICATION**



Contractor agrees that the Contractor shall indemnify, defend and hold harmless the City, its officers, employees and agents, from and against any and all loss, damage, injuries, claims, cause or causes of action, or any liability whatsoever resulting from, or arising out of, or in connection with the Contractor's obligations or actions under this Contract caused by any willful or negligent error, omission or act or a failure to observe any applicable standard of care by the Contractor or any person employed by it or anyone for whose acts the Contractor is legally liable. In consideration of the award of this Contract, to the extent damages are covered by insurance, the Contractor agrees to waive all rights of subrogation against the City, its subsidiary, parent, associated and/or affiliated entities, successors, or assigns, its elected officials, trustees, employees, agents, and volunteers for losses arising from the work performed by the Contractor for the City. The indemnification obligation shall survive the expiration or termination of this Contract.

## **17. INDEPENDENT CONTRACTOR**

In the performance of the Contractor's obligations under this Contract, it is understood, acknowledged and agreed between the parties that the Contractor is at all times acting and performing as an independent contractor, and the City shall neither have nor exercise any control or direction over the manner and means by which the Contractor performs the Contractor's obligations under this Contract, except as otherwise stated within the Contract terms. The City shall not provide any direction to the Contractor on the work necessary to complete the project. Contractor understands that it is an independent contractor responsible for knowing how to perform all work or tasks necessary to complete project. The Contractor understands and agrees that the Contractor and the Contractor's employees, agents, servants, or other personnel are not City employees. The Contractor shall be solely responsible for payment of salaries, wages, payroll taxes, unemployment benefits or any other form of compensation or benefit to the Contractor or any of the Contractor's employees, agents, servants or other personnel performing services or work under this Contract, whether it is of a direct or indirect nature. Further in that regard, it is expressly understood and agreed that for such purposes neither the Contractor nor the Contractor's employees, agents, servants or other personnel shall be entitled to any City payroll, insurance, unemployment, worker's compensation, retirement or any other benefits whatsoever.

## **18. APPLICABLE LAW AND LICENSES**

In the conduct of the services or work contemplated in this Contract, the Contractor shall ensure that the Contractor and all subcontractors comply with all applicable state, federal and City and local law, rules and regulations, technical standards or specifications. The Contractor shall qualify for and obtain any required licenses prior to commencement of work.

## **19. PRIOR AGREEMENTS**

This is a completely integrated Contract and contains the entire agreement between the parties. Any prior written or oral agreements or representations regarding this Contract shall be of no effect and shall not be binding on the City. This Contract may only be amended in writing, and executed by duly authorized representatives of the parties hereto.

## **20. INTELLECTUAL PROPERTY**



The Parties hereby agree, and acknowledge, that all products, items writings, designs, models, examples, or other work product of the Contractor produced pursuant to this Contract are works made for hire, and that the City owns, has, and possesses any and all ownership rights and interests to any work products of the Contractor made under this Contract, including any and all copyright, trademark, or patent rights, and that compensation to the Contractor for Agreement and acknowledgment of this intellectual property right section of this Contract is included in any compensation or price whatsoever paid to the Contractor under this Contract. It is the intent of the parties that the City shall have full ownership and control of the Contractor's work products produced pursuant to this Contract, and the Contractor specifically waives and assigns to the City all rights which Contractor may have under the 1990 Visual Artists Rights Act, federal, and state law, as now written or later amended or provided. In the event any products, items writings, designs, models, examples, or other work product produced pursuant to this Contract is deemed by a court of competent jurisdiction not to be a work for hire under federal copyright laws, this intellectual property rights provision shall act as an irrevocable assignment to the City by the Contractor of any and all copyrights, trademark rights, or patent rights in the Contractor's products, items writings, designs, models, examples, or other work product produced pursuant to this Contract, including all rights in perpetuity. Under this irrevocable assignment, the Contractor hereby assigns to the City the sole and exclusive right, title, and interest in and to the Contractor's products, items writings, designs, models, examples, or other work product produced pursuant to this Contract, without further consideration, and agrees to assist the City in registering and from time to time enforcing all copyrights and other rights and protections relating to the Contractor's products, items writings, designs, models, examples, or other work product in any and all countries. It is the Contractor's specific intent to assign all right, title, and interest whatsoever in any and all copyright rights in the Contractor's products, items writings, designs, models, examples, or other work product produced pursuant to this Contract, in any media and for any purpose, including all rights of renewal and extension, to the City. To that end, the Contractor agrees to execute and deliver all necessary documents requested by the City in connection therewith and appoints the City as Contractor's agent and attorney-in-fact to act for and in Contractor's behalf and stead to execute, register, and file any such applications, and to do all other lawfully permitted acts to further the registration, prosecution, issuance, renewals, and extensions of copyrights or other protections with the same legal force and effect as if executed by the Contractor; further, the parties expressly agree that the provisions of this intellectual property rights section shall be binding upon the parties and their heirs, legal representatives, successors, and assigns.

## **21. WAIVERS**

No waiver of default by the City of any of the terms, covenants, and conditions hereof to be performed, kept, and observed by the Contractor shall be construed, or shall operate, as a waiver of any subsequent default of any of the terms, covenants, or conditions herein contained to be performed, kept, and observed by the Contractor.

## **22. THIRD PARTIES**

It is expressly understood and agreed that enforcement of the terms and conditions of this Contract, and all rights of action relating to such enforcement, shall be strictly reserved to the Parties hereto, and nothing contained in this Contract shall give or allow any such claim or right of action by any other or third person or entity on such Contract. It is the express intention of the



Parties hereto that any person or entity, other than the Parties to this Contract, receiving services or benefits under this Contract shall be deemed to be incidental beneficiaries only.

## **23. TERMINATION**

### **A. Termination for Convenience.**

By signing this Contract, Contractor represents that it is a sophisticated business and enters into the Contract voluntarily, has calculated all business risks associated with this Contract, and understands and assumes all risks of being terminated for convenience, whether such risks are known or not known. Contractor agrees that the City may terminate this Contract at any time for convenience of the City, upon written notice to the Contractor. Contractor expressly agrees to and assumes the risk that the City shall not be liable for any costs or fees of whatsoever kind and nature if termination for convenience occurs before Contractor begins any work or portion of the work. Contractor further expressly agrees and assumes the risks that the City shall not be liable for any unperformed work, anticipated profits, overhead, mobilizations costs, set-up, demobilization costs, relocation costs of employees, layoffs or severance costs, administrative costs, productivity costs, losses on disposal of equipment or materials, cost associated with the termination of subcontractors, costs associated with purchase orders or purchases, or any other costs or fees of any kind and nature, if Contractor has started or performed portions of the Contract prior to receiving notice from the City. The City shall be liable only for the portions of work Contractor actually satisfactorily completed up to the point of the issuance of the Notice of Termination for convenience. Upon receipt of this notice the Contractor shall immediately: discontinue all services affected (unless the notice directs otherwise), and deliver to the City all data, drawings, specifications, reports, estimates, summaries, and other information and materials accumulated in performing this Contract, whether completed or in process.

### **B. Termination for Cause: The occurrence of any one or more of the following events (“Event of Default”) will justify termination for cause:**

1. Contractor’s failure to perform the work in accordance with the Contract Documents (including, but not limited to, failure to supply sufficient skilled workers or suitable materials or equipment or failure to adhere to the progress schedule as adjusted from time to time.
2. Contractor’s disregard of the laws or regulations of any public body having jurisdiction.
3. Contractor’s disregard of the authority of Project Manager.
4. Contractor’s violation in any material provision of the Contract Documents.
5. Contractor’s failure to make prompt payments to its subcontractors, and suppliers of any tier, or laborers or any person working on the work by, through, or under the Contractor or any of them, any all of their employees, officers, servants, members, and agents.
6. Contractor files a petition commencing a voluntary case under the U.S. Bankruptcy Code, or for liquidation, reorganization, or an arrangement pursuant to any other U.S. or state bankruptcy Laws, or shall be adjudicated a debtor or be declared bankrupt or insolvent under the U.S. Bankruptcy Code, or any other federal or state laws relating to bankruptcy, insolvency, winding-up, or adjustment of debts, or makes a general assignment for the benefit of creditors, or admits in writing its inability to pay its debts generally as they become due, or if a petition commencing an involuntary case under the U.S. Bankruptcy Code or an answer proposing the adjudication of Contractor as a debtor or bankrupt or proposing its liquidation or reorganization pursuant to the Bankruptcy Code or any other U.S. federal or state bankruptcy laws is filed in any court and Contractor consents to or



acquiesces in the filing of that pleading or the petition or answer is not discharged or denied within sixty (60) Calendar Days after it is filed.

7. A custodian, receiver, trustee or liquidator of Contractor, all or substantially all of the assets or business of Contractor, or of Contractor's interest in the Work or the Contract, is appointed in any proceeding brought against Contractor and not discharged within sixty (60) Calendar Days after that appointment, or if Contractor shall consent to or acquiesces in that appointment.
8. Contractor fails to commence correction of defective work or fails to correct defective work within a reasonable period of time after written notice.

If one or more of the events identified in Paragraphs 1-8 above occur, City may give Contractor written notice of the event and direct the event be cured. Any such Notice to Cure will provide Contractor a minimum of ten (10) calendar days to prepare and submit to the Project Manager a plan to correct the Event of Default. If such plan to correct the Event of Default is not submitted to the Project Manager within ten (10) days after the date of the written notice or such plan is unacceptable to the City, the City may, give Contractor (and the Surety, if any) written notice that Contractor's services are being terminated for cause. Upon delivery of the termination notice, City may terminate the services of Contractor in whole or in part, exclude Contractor from the site, and take possession of the work and of all Contractor's tools, appliances, construction equipment, and machinery at the project site, and use the same to the full extent they could be used by Contractor (without liability to Contractor for trespass or conversion), incorporate in the work all materials and equipment stored at the site or for which City has paid Contractor but which are stored elsewhere, and finish the work as City may deem expedient. In such case, Contractor shall not be entitled to receive any further payment until Certificate of Completion of the work. In the event City terminates this Contract for Cause and the cost of completing the work exceeds the unpaid balance of the Contract price, Contractor shall pay City for any costs of completion which exceed the Contract price when combined with all amounts previously paid to Contractor. When exercising any rights or remedies under this paragraph City shall not be required to obtain the lowest price for the work performed. Should the cost of such completion, including all proper charges, be less than the original Contract price, the amount so saved shall accrue to the City. Neither the City nor any officer, agent or employee of the City shall be in any way liable or accountable to the Contractor or the Surety for the method by which the completion of the said work, or any portion thereof, may be accomplished or for the price paid.

Where Contractor's services have been so terminated by City, the termination will not affect any rights or remedies of City against Contractor or Surety then existing or which may thereafter accrue. Any retention or payment of moneys due Contractor by City will not release Contractor from liability.

- C. Termination Notice. Upon receipt of a termination notice, whether for convenience or cause, the Contractor shall immediately: discontinue all services affected (unless the notice directs otherwise), and deliver to the City all data, drawings, specifications, reports, estimates, summaries, and other information and materials accumulated in performing this Contract, whether completed or in process.
- D. Removal of Equipment. Except as provided above, in the case of termination of this Contract before completion from any cause whatever, the Contractor, if notified to do so by the City, shall promptly remove any part or all of Contractor's equipment and supplies from the property





of the City, failing which the City shall have the right to remove such equipment and supplies at the expense of the Contractor.

## **24. BOOKS OF ACCOUNT AND AUDITING**

The Contractor shall make available to the City if requested, true and complete records, which support billing statements, reports, performance indices, and all other related documentation. The City's authorized representatives shall have access during reasonable hours to all records, which are deemed appropriate to auditing billing statements, reports, performance indices, and all other related documentation. The Contractor agrees that it will keep and preserve for at least seven years all documents related to the Contract which are routinely prepared, collected or compiled by the Contractor during the performance of this Contract.

The City's Auditor and the Auditor's authorized representatives shall have the right at any time to audit all of the related documentation. The Contractor shall make all documentation available for examination at the Auditor's request at either the Auditor's or Contractor's offices, and without expense to the City.

## **25. COMPLIANCE WITH IMMIGRATION REFORM AND CONTROL ACT OF 1986**

Contractor certifies that Contractor has complied with the United States Immigration Reform and Control Act of 1986. All persons employed by Contractor for performance of this Contract have completed and signed Form I-9 verifying their identities and authorization for employment.

## **26. LABOR**

The Contractor shall employ only competent and skilled workmen and foremen in the conduct of work on this Contract. The Contractor shall at all times enforce strict discipline and good order among Contractor's employees. The Project Manager shall have the authority to order the removal from the work of any person, including Contractor's or any subcontractor's employees, who refuses or neglects to observe any of the provisions of these Plans or Specifications, or who is incompetent, abusive, threatening, or disorderly in conduct and any such person shall not again be employed on the Project.

In accord with the Keep Jobs in Colorado Act, codified at sections 8-17-101, et seq., C.R.S., Colorado labor shall be employed to perform the work to the extent of not less than eighty percent (80%) of each type or class of labor in the several classifications of skilled and common labor employed on this Project et seq.; provided however, that this paragraph shall not apply if the Project receives federal funding.

In no event shall the City be responsible for overtime pay.

## **27. GRATUITIES**

- A. This Contract may be terminated if the Mayor, the Mayor's designee, and/or the Procurement Services Manager determine, in their sole discretion, that the Contractor or any officer, employee, agent, or other representative whatsoever, of the Contractor offered or gave a gift or hospitality to a City officer, employee, agent or Contractor for the purpose of influencing



any decision to grant a City contract or to obtain favorable treatment under any City contract.

- B. The terms "hospitality" and "gift" include, but are not limited to, any payment, subscription, advance, forbearance, acceptance, rendering or deposit of money, services, or anything of value given or offered, including but not limited to food, lodging, transportation, recreation or entertainment, token or award.
- C. Contract termination under this provision shall constitute a breach of contract by the Contractor, and the Contractor shall be liable to the City for all costs of reletting the contract or completion of the project. Further, if the Contractor is terminated under this provision, or violates this provision but is not terminated, the Contractor shall be subject to debarment under the City's Procurement Regulations. The rights and remedies of the City provided in this clause shall not be exclusive and are in addition to any other rights and remedies provided by law or under this Contract.

## **28. NON-DISCRIMINATION**

- A. In accord with section 24-34-402, C.R.S., Title VII of the Civil Rights Act of 1964, Americans with Disabilities Act of 1990 as amended, all applicable federal and state laws, the Contractor will not discriminate against any employee or applicant for employment because of disability, race, creed, color, sex, sexual orientation, gender identity, gender expression, religion, age, national origin, or ancestry.
- B. The Contractor agrees to post in conspicuous places, available to employees and applicants for employment, notices to be provided setting forth the provisions of this nondiscrimination clause.
- C. The Contractor will, in all solicitations or advertisements for employees placed by or on behalf of the Contractor, state that all qualified applicants will receive consideration for employment without regard to disability, race, creed, color, sex, sexual orientation, gender identity, gender expression, religion, age, national origin, or ancestry.

## **29. ORDER OF PRECEDENCE**

Any inconsistency in this Contract shall be resolved by giving precedence in the following order:

- A. This Contract document with its terms and conditions
- B. Specific Construction Terms and Conditions
- C. General Construction Terms and Conditions
- D. The Statement of Work
- E. Specific Specifications
- F. General Specifications
- G. Other Appendices, Attachments, Exhibits, or Schedules

## **30. HEADINGS**

The section headings contained in this Contract are for reference purposes only and shall not affect the meaning or interpretation of this Contract.



### **31. DISPUTES**

- A. All administrative and contractual disputes arising from or related to this Contract other than those arising under Unanticipated Circumstances provisions (in section 107.27 of Schedule B General Construction Terms and Conditions) shall be addressed in the following manner:
1. If either Party disputes or disagrees with a Contract term or the other Party's interpretation of a Contract term or has any other administrative or contractual dispute not addressed in the Unanticipated Circumstances provisions, such Party shall promptly give the other Party written notice of said dispute.
  2. The Parties shall hold a meeting as soon as reasonably possible, but in no event later than thirty (30) calendar days from the initial written notice of the dispute, attended by persons with decision-making authority regarding the dispute, to attempt in good faith to negotiate a resolution of the dispute; provided, however, that no such meeting shall be deemed to vitiate or reduce the obligations and liabilities of the Parties or be deemed a waiver by a Party of any remedies to which such Party would otherwise be entitled unless otherwise agreed to by the Parties in writing.
  3. If, within thirty (30) calendar days after such meeting, the Parties have not succeeded in negotiating a resolution of the dispute, they agree to submit the dispute to non-binding mediation and to bear equally the costs of the mediation.
  4. The Parties will jointly appoint a mutually acceptable mediator. If they fail to do so within twenty (20) calendar days from the conclusion of the negotiation period, they shall each select a mediator. The two mediators will then appoint a third mediator who shall conduct mediation for the Parties as the sole mediator.
  5. The Parties agree to participate in good faith in the mediation and negotiations for a period of thirty (30) calendar days. The substantive and procedural law of the State of Colorado shall apply to the proceedings. If the Parties are not successful in resolving the dispute through mediation, then the Parties shall be free to pursue any other remedy afforded by the laws of the State of Colorado.
  6. Until final resolution of any dispute hereunder, the Contractor shall diligently proceed with the performance of this Contract as directed by the City. For purposes of this Contract, termination for convenience shall not be deemed a dispute. The City of Colorado Springs and the Contractor agree to notify each other in a timely manner of any claim, dispute, or cause of action arising from or related to this Contract, and to negotiate in good faith to resolve any such claim, dispute, or cause of action. To the extent that such negotiations fail, the City of Colorado Springs and the Contractor agree that any lawsuit or cause of action that arises from or is related to this Contract shall be filed with and litigated only by the Colorado District Court for El Paso County, CO.

### **32. DELIVERY**

The City may cancel this Contract or any portion thereof if delivery is not made when and as specified, time being of the essence in this Contract. Contractor shall pay the City for any loss or damage sustained by the City because of failure to perform in accordance with this Contract.

### **33. PAYMENTS**

All invoices shall be sent to the Project Manager identified in this Contract.



The City will pay the Contractor, upon submission of proper invoices, the prices stipulated in the Contract for services rendered and accepted, less any deductions provided in this Contract within 30 days (Net 30). The City will not pay late fees or interest. Any discount payment terms offered on the invoice may be taken by the City.

All payments for Construction will be made in accordance with the Payment provisions found in Schedule B – General Construction Terms and Conditions.

Each invoice must contain at least the following information:

Contract number, issued purchase order number, invoice number, invoice date, timeframe covered by invoice, type and amount of labor and materials used for that time period, dollar amount in unit price, extended price, and total value of invoice.

### **34. INSPECTION OF SERVICES**

The Contractor is responsible for performing or having performed all inspections and tests necessary to substantiate that the services furnished under this Contract conform to Contract requirements, including any applicable technical requirements for specified manufacturers' parts. This clause takes precedence over any City inspection and testing required in the Contract's specifications, except for specialized inspections or tests specified to be performed solely by the City.

- A. Definition of "services", as used in this clause, includes services performed, workmanship, and material furnished or utilized in the performance of services.
- B. The Contractor shall provide and maintain an inspection system acceptable to the City covering the services under this Contract. Complete records of all inspection work performed by the Contractor shall be maintained and made available to the City during Contract performance and for as long afterwards as the Contract requires.
- C. The City has the right to inspect and test all services called for by the Contract, to the extent practicable at all times and places during the term of the Contract. The City will perform inspections and tests in a manner that will not unduly delay the work.
- D. If the City performs inspections or test on the premises of the Contractor or a subcontractor, the Contractor shall furnish, and shall require subcontractors to furnish, at no increase in Contract price, all reasonable facilities and assistance for the safe and convenient performance of these duties.

### **35. SECURITY**

The City maintains security requirements regarding access to City buildings and other City workplaces and worksites on City property. All Contractor personnel accessing City buildings, workplaces, or worksites, may be required to produce a valid, Government issued picture identification. Contractor personnel lacking such identification may not be allowed access to such sites. No costs incurred by the Contractor due to City security requirements shall be allowable or payable under this Contract.



### **36. TIME IS OF THE ESSENCE**

In as much as the Contract concerns a needed or required service, the terms, conditions, and provisions of the Contract relating to the time of performance and completion of work are of the essence of this Contract. The Contractor shall begin work on the day specified and shall prosecute the work diligently so as to assure completion of the work within the number of calendar days or date specified, or the date to which the time for completion may have been extended.

### **37. EMPLOYMENT OF LABOR**

The Contractor shall comply with, and defend and hold the City harmless from any violation of all laws and lawful rules and regulations, both of the State of Colorado and of the United States, relating to Workmen's Compensation, unemployment compensation, Social Security, payment for overtime, and all other expenses and conditions of employment under this Contract.

### **38. SALES TAX**

The Contractor must have a tax-exemption certificate from the Colorado Department of Revenue for this project. The certificate does not apply to City of Colorado Springs Sales and Use Tax which shall be applicable. The tax exempt project number and the exemption certificate only applies to County, PPRTA (Pikes Peak Rural Transportation Authority), and State taxes when purchasing construction and building materials **to be incorporated into this project**.

Furthermore, the exemption **does not** include or apply to the purchase or rental of equipment, supplies or materials that **do not become a part of the completed project or structure**. Such purchases and rentals are subject to full applicable taxation.

All contracts with subcontractors must include the City of Colorado Springs Sales and Use Tax on the work covered by the Contract, and other taxes as applicable.

Note: For all equipment, materials and supplies incorporated into the work purchased from vendors or suppliers not licensed to collect City Sales Tax (i.e. out of state suppliers, etc.), City Use Tax is due and payable to the City. The Contractor shall execute and deliver and shall cause the Contractor's subcontractors to execute and deliver to the City Sales Tax Office, the appropriate ST forms as designated by the City Sales Tax Office. These forms shall list all said equipment, materials and supplies and the corresponding use tax due, along with payment for said taxes. Any outstanding taxes due may be withheld from the final payment due the Contractor and may result in suspension of Contractor from bidding on City projects.

Forms and instructions can be downloaded at <https://coloradosprings.gov/sales-tax>. Questions can be directed to the City Sales Tax Division at (719) 385-5903.

Our Registration Numbers are as follows:

City of Colorado Springs

Federal I.D.: 84-6000573

Federal Excise: A-138557

State Sales Tax: 98-03479



The Contractor's payment or exemption of State of Colorado, El Paso County and City Sales and Use Taxes shall be as specified herein.

### **39. SEVERABILITY**

If any terms, conditions, or provisions of this Contract shall be held unconstitutional, illegal, or void, such finding shall not affect any other terms, conditions, or provisions of this Contract.

### **40. LIABILITY OF CITY EMPLOYEES**

All authorized representatives of the City are acting solely as agents and representatives of the City when carrying out and exercising the power or authority granted to them under the Contract. There shall not be any liability on them either personally or as employees of the City.

### **41. USE OF CITY NAME OR LOGO**

Except as otherwise provided in this Contract, the Contractor shall not refer to this Contract or the City of Colorado Springs in any advertising or promotions in such a manner as to state or imply that the product or service provided is endorsed or preferred by the City of Colorado Springs, its employees, or its Departments, or is considered by these entities to be superior to other products or services. Any use of the name or logo of the City of Colorado Springs in advertising or promotions must be approved in writing by the City of Colorado Springs Contracts Specialist assigned to the Contract prior to such use.

### **42. TRAVEL**

If travel expenses are included as a line item in this Contract, all travel expenses incurred and billable by the Contractor are subject to City approval. Air travel shall be limited to the round trip "economy coach" fare. Travel from the Colorado Springs Airport is encouraged. Unless there are extenuating circumstances, the Contractor should take advantage of lower airfares by purchasing tickets more than 14 days in advance of travel. In-state travel by air must be more economical than travel by private vehicle. Use of a private vehicle may be reimbursed per mile at the current rate published by the IRS annually. Short-term parking, long-term parking or cab fare associated with airport departure and arrival may be allowable expenses. Valet parking will not be allowed unless it is the least expensive or only option. Car rental rates may be reimbursed for car rentals no greater than the intermediate or standard classification. The City will not reimburse any other travel methods or expenses. The City will pay for lodging, meals, and miscellaneous expenses on a per diem basis only, in accordance with the current per diem rates published by the IRS annually. The City will not pay for Contractor expenses exceeding the per diem rates. Receipts for all reimbursable expenses must be provided with the Contractor's invoice.

### **43. ELECTRONIC SIGNATURE**

This Agreement and all other documents contemplated hereunder may be executed using electronic signature with delivery via facsimile transmission, by scanning and transmission of electronic files in Portable Document Format (PDF) or other readily available file format, or by copy transmitted via email, or by other electronic means and in one or more counterparts, each of which shall be (i) an original, and all of which taken together shall constitute one and the same



agreement, (ii) a valid and binding agreement and fully admissible under state and federal rules of evidence, and (iii) enforceable in accordance with its terms

#### **44. APPENDICES**

The following Appendices are made a part of this Agreement:

1. Schedule A – Price Sheet
2. Schedule B – General Construction Terms and Conditions
3. Schedule C – Special Contract Terms and Conditions
4. Schedule D – General Specifications
5. Schedule E – Special and Technical Specifications
6. Schedule F – Scope of Work
7. Exhibit 1 – Performance, Labor and Material Payment, and Maintenance Bonds
8. Exhibit 2 – Minimum Insurance Requirements



**CONTRACT SIGNATURE PAGE**

**IN WITNESS WHEREOF**, the parties have caused these presents to be executed on the day and the year first above written.

This Contract is executed in one (1) original copy.

<b>THE CITY OF COLORADO SPRINGS, COLORADO:</b>

<b>SECOND PARTY:</b>	
Corporate Name	
Signature	Date
Title	





**EXHIBIT 3 – EVALUATION SCORESHEET**

**PROPOSAL EVALUATION SCORE SHEET  
SOLICITATION NUMBER AND TITLE:**

RFP EVALUATION CRITERIA DESCRIPTION	SCORE
<p><b>1. TECHNICAL AREA</b></p> <p>The Offeror must explain its overall solution, considering the scope of work or statement of work provided. The content must include, but not necessarily be limited to, the following information.</p>	
<p><b>A. Understanding of and compliance with technical requirements</b></p>	
<p>In the Technical Area, the Offeror should address each work area in sufficient detail to demonstrate a clear and full understanding of the work. The proposal should not merely parrot the requirements of the RFP. Further, the Offeror should provide evidence of sufficient planning to ensure the work is completed on schedule and within budget.</p> <p>Consider the following questions.</p> <ol style="list-style-type: none"> <li>1. Does the proposal demonstrate a firm understanding of the requirements and goals of the Statement of Work, as well as industry standards and reasonable expectations for a company in the industry?</li> <li>2. Does the proposal fully and completely address each requirement and goal of the Statement of Work and Plan Set Work List Table?</li> <li>3. Does the proposal provide solutions to indicate that requirements and goals will be met on schedule?</li> <li>4. Does the technical solution seem realistic?</li> <li>5. Does it generally appear that the Offeror knows and thoroughly understands the business and requirement?</li> </ol> <p><b>COMMENTS:</b></p>	<p><b>5 – Exceptional</b>  <b>4 – Very Good</b>  <b>3 – Satisfactory</b>  <b>2 – Marginal</b>  <b>1 – Unacceptable</b></p>
<p><b>B. Project Approach</b></p>	
<p>In the Technical Area, the Offeror should clearly present proposed solutions and indicate that it has performed adequate planning to accomplish tasks as defined in the Statement of Work. Innovations, efficiencies, and detailed specifics are all encouraged.</p> <p>The Offeror must at least address the following areas:</p> <ol style="list-style-type: none"> <li>1. Construction phasing and traffic control for the project. Explain the phases, traffic control for each phase, and the logic in the</li> </ol>	<p><b>5 – Exceptional</b>  <b>4 – Very Good</b>  <b>3 – Satisfactory</b>  <b>2 – Marginal</b>  <b>1 – Unacceptable</b></p>



<p>D.</p> <p>E.</p> <p>F.</p> <p>G.</p> <p>H.</p> <p>I.</p> <p>Consider the following questions.</p> <p><b>COMMENTS:</b></p>	<p>construction phasing.</p> <p>2. Erosion and sediment control during all phases of construction as well as post construction efforts through permit closure.</p> <p>3. Coordination with utilities. Discuss your understanding of the key utility relocations required for this project and how you will coordinate and phase your construction to both facilitate and accommodate those relocations and the constraints that they impose.</p> <p>4. Schedule Management. Discuss your approach to schedule management including updating and reporting progress of the work.</p> <p>5. Quality Control. Discuss your quality control plan, processes and approach to ensure that the City receives a quality product.</p> <p>6. Safety. Discuss the contractor's approach and commitment to safety for both construction workers and the public traveling through the construction site.</p> <p>7. Potential issues that your firm foresees with this project and how you would make adjustments if encountered. Describe factors limiting construction phasing flexibility and potential remedies.</p> <p>1. Does the proposal include a complete plan to accomplish each requirement, including subcontracting (if applicable)?</p> <p>2. Does the proposal demonstrate that appropriate and qualified personnel and equipment will be provided to carry out the requirement?</p> <p>3. Is the proper level of effort directed toward each requirement? Does the level of effort look unrealistically low or unreasonably high?</p>	
<p>Sum of Ratings in Technical Area (Add numbers in Section 1.A. and 1.B):</p>		
<p><b>2. MANAGEMENT AREA</b></p> <p>The Offeror must explain its method of managing the work to be performed. The content must include, but no necessarily be limited to, the following information.</p>		
<p><b>A. Program Management Controls</b></p>		
<p>In the Management Area, the Offeror should provide a plan of operation, to include management of personnel, workload, schedule, and budget. It should also include an organization chart which demonstrates clear and effective lines of authority,</p>		<p><b>5 – Exceptional</b>  <b>4 – Very Good</b>  <b>3 – Satisfactory</b>  <b>2 – Marginal</b></p>



<p>responsibility, and communication for management, supervisory, and technical personnel. The plan should address which job classification or personnel will be assigned to each task and how that determination is made. Basic human resource management concepts should be addressed, including hiring, firing, discipline, incentive plans, etc. If the Offeror plans to subcontract more than 10% of the work, include information on how the Offeror plans to manage its subcontractors.</p> <p>The Offeror shall provide a detailed construction schedule for the project showing the key construction activities and how they will meet or better the County's timeframe and maximize construction efficiency to provide the best value to the City and minimize impacts to the public such as avoiding closures on Veterans Day and Memorial Day holidays. The schedule shall be based on the Offeror's understanding and approach to the work as addressed above. Schedules submitted for this proposal shall assume a start date of October 2024.</p> <p>Consider the following questions.</p> <ol style="list-style-type: none"> <li>1. Does the proposal address the issues above in sufficient detail to demonstrate a sophisticated and mature management control system?</li> <li>2. Are program management controls consistent with the technical portion of the proposal, especially regarding schedule and level of effort?</li> <li>3. Does the plan and controls indicate that the Offeror will obtain, keep, and efficiently utilize high quality personnel?</li> <li>4. Does the offer address corrective actions?</li> <li>5. Does the proposal explain how the Offeror will remain within schedule and budget?</li> </ol> <p><b>COMMENTS:</b></p>	<p><b>1 – Unacceptable</b></p>
<p><b>B. Past Performance/Relevant Experience and Key Personnel</b></p>	
<p>In the Management Area, the Offeror should provide at least three references or contracts demonstrating that it successfully provided services/products same or similar to those required in the RFP. The proposal should adequately explain how the projects were completed on schedule and within budget.</p> <p>Consider the following questions.</p> <ol style="list-style-type: none"> <li>1. Does the proposal include at least three references or past performance citations?</li> <li>2. Are the references or past performance citations relevant to the requirements of the Statement of Work of the RFP?</li> <li>3. Does the Offeror explain how they were successful on the projects provided as past performance?</li> <li>4. Does the Offeror apply the past performance to the City requirement in such a way as to demonstrate added value due to experience?</li> </ol>	<p><b>5 – Exceptional</b>  <b>4 – Very Good</b>  <b>3 – Satisfactory</b>  <b>2 – Marginal</b>  <b>1 – Unacceptable</b></p>



<p>In the Management Area, resumes must be provided for all personnel considered key, as required by the RFP. It is highly recommended that the Offeror provide sufficient content and detail to answer completely the following questions. Resumes do not count toward the page limitation. Explain how the key personnel were related to the projects cited as relevant past performance.</p> <p>Consider the following questions.</p> <ol style="list-style-type: none"> <li>1. Does the Offeror provide complete resumes, including education, experience, background information, accomplishments, and other pertinent information?</li> <li>2. Does the Offeror provide resumes for all key personnel, as required by the RFP?</li> <li>3. Do the resumes demonstrate adequate professional, technical, and management levels to accomplish the work effectively and efficiently?</li> </ol> <p><b>COMMENTS:</b></p>	
<p>Sum of Ratings in Management Area (Add numbers in Sections 2.A. and 2. B.)</p>	
<p><b>3. PRICE/COST AREA</b></p>	
<p>In the Price Area, the Offeror should provide a detailed breakdown of the price for each year of performance. The price must be fully loaded/all-inclusive and include unit cost for material, labor, other direct costs (e.g. travel), indirect costs (i.e. overhead and general and administrative costs), and profit/fee. Offers must include sufficient detail to allow insight into the fairness and reasonableness of the price. If the contract type will be T&amp;M, labor categories, labor rates, separated profit, and estimated material costs must be included in detail.</p> <p>In addition, although price may not be the most important factor, it is still very important to the City of Colorado Springs. The Offeror's pricing must be competitive as compared to the budget amount, market pricing in the industry, and the pricing of the other Offerors.</p> <p>Consider the following questions:</p> <ol style="list-style-type: none"> <li>1. How does the price compare to the industry competition?</li> <li>2. If low, is it unrealistically low?</li> <li>3. If high, is there demonstrated added value for the additional cost?</li> </ol> <p><b>COMMENTS:</b></p>	<p><b>5 – Exceptional</b>  <b>4 – Very Good</b>  <b>3 – Satisfactory</b>  <b>2 – Marginal</b>  <b>1 – Unacceptable</b></p>
<p>Total Price/Cost Area (Insert number from Section 3 evaluation above):</p>	



<b>4. PROPOSAL PRESENTATION</b>	
Presentation is an important factor. Offerors should provide a highly professional product, which is complete, accurate, easily understood, and effectively presented.  <b>COMMENTS:</b>	<b>5 – Exceptional</b> <b>4 – Very Good</b> <b>3 – Satisfactory</b> <b>2 – Marginal</b> <b>1 – Unacceptable</b>
Total Proposal Presentation Area (Insert number from Section 4 evaluation above):	
<b>EXCEPTIONS PROPOSED</b>	
What (if any) exceptions (redlines to our terms and conditions) were proposed? Are they acceptable?  <b>COMMENTS:</b>	<b>Pass/Fail</b>
<b>INSURANCE EXCEPTIONS PROPOSED</b>	
What (if any) exceptions (redlines to our insurance terms and conditions) were proposed? Are they acceptable?  <b>COMMENTS:</b>	<b>Pass/Fail</b>
<b>TOTAL SCORE – Add Evaluation Scores from Sections 1-4 and location bonus (if applicable). The sum is the total score.</b>	Total Score:



**EXHIBIT 4 – FEDERAL FORMS**

**FOLLOWS THIS PAGE**

**EXHIBIT 4 – FEDERAL FORMS**

**CERTIFICATION REGARDING DEBARMENT, SUSPENSION AND OTHER RESPONSIBILITY MATTERS**

The undersigned duly authorized official of the proposer certifies to the best of its knowledge and belief, that it and its principals:

- A. Are not presently debarred, suspended, proposed for debarment, and declared ineligible or voluntarily excluded from covered transactions by any Federal department or agency.
- B. Have not within a three-year period preceding this proposal been convicted of or had a civil judgement rendered against them for commission of fraud or a criminal offense in connection with obtaining, attempting to obtain or performing a public (federal, state or local) transaction or contract under a public transaction; violation of federal or state antitrust statutes or commission of embezzlement, theft, forgery, bribery, falsification, or destruction of records, making false statements or receiving stolen property.
- C. Are not presently indicted for or otherwise criminally or civilly charged by a governmental entity (federal, state or local) with commission of any of the offenses enumerated in paragraph (B) of this certification; and
- D. Have not within a three-year period preceding this application/proposal had one or more public transaction (federal, state or local) terminated for cause or default.
- E. Are not on the Comptroller General’s List of Ineligible Bidders or any similar list maintained by any other governmental entity.

Where the proposer is unable to certify to any of the statements in this certification, such prospective participant shall attach an explanation to this proposal.

**(Check One)**

**I DO CERTIFY (\_\_\_\_)**

**I DO NOT CERTIFY (\_\_\_\_)**

**Date:** \_\_\_\_\_

**Signature:** \_\_\_\_\_

**Title:** \_\_\_\_\_

## RESTRICTIONS ON LOBBYING CERTIFICATION

Pursuant to United States Public Law 101-121, Section 319, the undersigned duly authorized official of the proposer hereby certifies, to the best of her/his knowledge and belief, that:

1. No Federal appropriated funds have paid or will be paid, by or on behalf of the undersigned, to any person for the purpose of influencing or attempting to influence an officer or employee of any agency, a Member of Congress, an officer or employee of Congress, or an employee of a Member of Congress, in connection with the awarding of any Federal contract, the making of any Federal grant, the making of any Federal loan, the entering into of any cooperative agreement, and the extension, continuation, renewal, amendment, or modification of any Federal contract, grant, loan, or cooperative agreement.
2. If any funds other than Federal appropriated funds have been paid or will be paid to any person or agency for influencing or attempting to influence an officer or employee of any agency, a Member of Congress, an officer or employee of Congress, or an employee of a Member of Congress, in connection with this Federal contract, grant, loan, or cooperative agreement, the undersigned shall complete and submit a Standard Form-LLL, "Disclosure Form to Report Lobbying", in accordance with its instructions.
3. The undersigned duly authorized official shall require and ensure that the language of this certification be included in any award documents for subcontracts, grants, loans, and cooperative agreements, and that all subcontractors shall so certify and disclose accordingly.

This Certification is a material representation of fact, upon which reliance was placed when this transaction was made or entered into. The submission of this Certification is a prerequisite for making or entering into this transaction, imposed by Title 31 USC Section 1352. Any proposer (person) who fails to file the required certification shall be subject to civil penalty of not less than ten thousand dollars (\$10,000) and not more than one hundred thousand dollars (\$100,000) for each such failure to file.

Proposer: \_\_\_\_\_

Signature: \_\_\_\_\_

Title: \_\_\_\_\_

Date: \_\_\_\_\_



**NON-COLLUSION AFFIDAVIT**

The undersigned duly authorized official of the proposer hereby certifies, to the best of her/his knowledge and belief, that:

1. That I am an officer or employee of the \_\_\_\_\_ (proposing entity) having the authority to sign on behalf of the corporation, and,
  
2. That the prices in the attached proposal were arrived at independently by \_\_\_\_\_ (proposing entity) without collusion, consultation, communication, or any agreement, for the purpose of restricting competition as to any matter relating to such prices with any other proposer or with any other competitor regarding an understanding, or planned common course of action with any other vendor of materials, supplies, equipment, or service described in the RFP/IFB designed to limit independent proposals or competition; and
  
3. That unless otherwise required by law, the contents and prices contained in the proposal have not been communicated by \_\_\_\_\_(proposing entity) or its employees or agents to any person not an employee or agent of \_\_\_\_\_ (proposing entity), or its surety on any bond furnished with the proposal, and will not be communicated to any such person prior to the official opening of the proposal; and,
  
4. That I have fully informed myself regarding the accuracy of the statements made in this affidavit.

Proposer: \_\_\_\_\_

Signature: \_\_\_\_\_

Title: \_\_\_\_\_

Date: \_\_\_\_\_

## EQUAL EMPLOYMENT STATUS REPORT

Contractor's Name \_\_\_\_\_

Street Address \_\_\_\_\_

City \_\_\_\_\_ State \_\_\_\_\_ Zip Code \_\_\_\_\_

This firm is:

<input type="checkbox"/>	Independently owned and operated
<input type="checkbox"/>	An affiliate parent company
<input type="checkbox"/>	A subsidiary of address
<input type="checkbox"/>	A division City and State

#	Statement	Has	Has Not
1	Developed and has on file an affirmative action program in conformance with 41 CFR 60-2		
2	Participated in any previous contract or subcontract subject to the equal opportunity clause either with the City of any Federal Agency		
3	Filed with the City, or where applicable, joint Reporting Committee, or other Federal Agency, all reports due under the applicable contract(s) or subcontract(s)		
4	Contractor's Equal Employment Opportunity Program been subject to a Federal Equal Opportunity Compliance Review, If so state date of Review: _____		

Signature \_\_\_\_\_

Date \_\_\_\_\_

Title \_\_\_\_\_

**BUILD AMERICA, BUY AMERICA (BABAA) (if applicable)**

The undersigned certifies, to the best of their knowledge and belief, that:

The Build America, Buy America Act (BABAA) requires that no federal financial assistance for “infrastructure” projects is provided “unless all of the iron, steel, manufactured products, and construction materials used in the project are produced in the United States.” Section 70914 of Public Law No. 117-58, §§ 70901-52.

The undersigned certifies that for the \_\_\_\_\_ (Project Name and Location) \_\_\_\_\_ the iron, steel, manufactured products, and construction materials used in this contract are in full compliance with the BABAA requirements including:

1. All iron and steel used in the project are produced in the United States. This means all manufacturing processes, from the initial melting stage through the application of coatings, occurred in the United States.
2. All manufactured products purchased with federal financial assistance must be produced in the United States. For a manufactured product to be considered produced in the United States, the cost of the components of the manufactured product that are mined, produced, or manufactured in the United States is greater than 55% of the total cost of all components of the manufactured product, unless another standard for determining the minimum amount of domestic content of the manufactured product has been established under applicable law or regulation.
3. All construction materials are manufactured in the United States. This means that all manufacturing processes for the construction material occurred in the United States.

“The, \_\_\_\_\_ [Contractor or Subcontractor] \_\_\_\_, certifies or affirms the truthfulness and accuracy of each statement of its certification and disclosure, if any. In addition, the [Contractor or Subcontractor] understands and agrees that the provisions of 31 U.S.C. Chap. 38, Administrative Remedies for False Claims and Statements, apply to this certification and disclosure, if any.”

\_\_\_\_\_  
Signature of [Contractor’s or Subcontractor’s] Authorized Official

\_\_\_\_\_  
Name and Title of [Contractor’s or Subcontractor’s] Authorized Official

\_\_\_\_\_  
Date



## **SCHEDULES**

Schedule A	Price Sheet
Schedule B	General Construction Terms and Conditions
Schedule C	Scope of Work
Schedule D	Special Provisions
Schedule E	Clauses for Contracts Subject to Federal Requirements
Schedule F	Project Specifications
Schedule G	Construction Plan Set



**SCHEDULE A – PRICE SHEET**

**PLEASE SUBMIT SCHEDULE A – PRICE SHEET IN EXCEL FORMAT**

**PLEASE ENTER TOTAL PROJECT COST IN BIDNET PRICE SHEET**



## **SCHEDULE B – GENERAL CONSTRUCTION TERMS AND CONDITIONS**

Schedule B -- General Construction Terms and Conditions, Version 100316 are hereby incorporated by reference, with the same force and effect as if they were given in full text. Upon request, the City will make their full text available. Also, the full text of a clause may be accessed electronically at this address:

<https://www.coloradosprings.gov/finance/page/procurement-regulations-and-documents>

The referenced General Construction Terms and Conditions will be incorporated in the resultant Contract.



## **SCHEDULE C – SCOPE OF WORK**

Overall, this project includes cleaning, structural repairs, and application of a protective coating on the Veterans Memorial clocktower, located in Memorial Park at 300 South Union Boulevard. Based on observations and testing performed in January 2022 and a petrographic investigation report issued on February 25, 2022, the concrete of the memorial is exhibiting cracking and deterioration due to severe alkali-silica reaction (ASR). Water-mitigating repairs are required to limit future deterioration.

The Veterans Memorial clocktower consists of five vertical concrete elements surrounding a round, concrete room. Non-concrete aspects on the vertical concrete elements include metal decorative elements at the top, speakers at the top, and embedded lightning protection. Non-concrete aspects on the central concrete room include the stone cap elements at the top and five embedded metal medallions.

The repair of the memorial will begin with the removal of the existing paint coating at the base of the columns, the patching of any damaged or spalled concrete. Next, all steel elements will be inspected for corrosion by the contractor, and all corroded elements will be cleaned and repainted. Once concrete and steel repairs are complete, the memorial columns will receive a penetrating corrosion inhibitor followed by a transparent silicone coating. Lastly, the memorial will receive flashing at the top of each of the five vertical concrete elements.

This project does not include concrete work on any surrounding sidewalk or repair of any of the adjacent memorials.



## **SCHEDULE D – SPECIAL PROVISIONS**

**ADA Standards:** It is a requirement of the City and required by law that any new or renovated facility meet the scoping and technical requirements of the 2010 ADA Standards for newly designed and constructed or altered local government facilities, public accommodations, and facilities. The selected Design Professional shall design the project so it both conforms to the 2010 ADA Standards, as applicable and as amended, and is readily accessible to and usable by individuals with disabilities. The selected Contractor shall build the project so it both conforms to the 2010 ADA Standards, as applicable and as amended, and is readily accessible to and usable by individuals with disabilities. Facilities that are designed, constructed, and/or altered facilities that meet or exceed the IBC 2015/ANSI A117.1 2009, used by Pikes Peak Regional Building Department, will be accepted as meeting or exceeding the 2010 ADA Standards.





**SCHEDULE E - CLAUSES FOR CONTRACTS SUBJECT TO FEDERAL REQUIREMENTS**

**FOLLOWS THIS PAGE**

## **SCHEDULE E - CLAUSES FOR CONTRACTS SUBJECT TO FEDERAL REQUIREMENTS**

### **1. EQUAL EMPLOYMENT OPPORTUNITY**

To view the City of Colorado Springs EEOP (Equal Employment Opportunity Plan) Utilization Report, the link is [www.coloradosprings.gov/eeop](http://www.coloradosprings.gov/eeop).

During the performance of this Contract, the Contractor agrees as follows:

A. The Contractor will not discriminate against any employee or applicant for employment because of race, color, religion, sex, or national origin. The Contractor will take affirmative action to ensure that applicants are employed, and that employees are treated during employment without regard to their race, color, religion, sex, or national origin. such action shall include, but not be limited to the following: Employment, upgrading, demotion, or transfer; recruitment or recruitment advertising; layoff or termination; rates of pay or other forms of compensation; and selection for training, including apprenticeship. The Contractor agrees to post in conspicuous places, available to employees and applicants for employment, notices to be provided setting forth the provisions of this nondiscrimination clause.

B. The Contractor will, in all solicitations or advertisements for employees placed by or on behalf of the Contractor, state that all qualified applicants will receive considerations for employment without regard to race, color, religion, sex, or national origin.

C. The Contractor will send to each labor union or representative of workers with which he has a collective bargaining agreement or other contract or understanding, a notice to be provided advising the said labor union or workers' representatives of the contractor's commitments under this section, and shall post copies of the notice in conspicuous places available to employees and applicants for employment.

D. The Contractor will comply with all provisions of Executive Order 11246 of September 24, 1965, and of the rules, regulations, and relevant orders of the Secretary of Labor.

E. The Contractor will furnish all information and reports required by Executive Order 11246 of September 24, 1965, and by rules, regulations, and orders of the Secretary of Labor, or pursuant thereto, and will permit access to his books, records, and accounts by the administering agency and the Secretary of Labor for purposes of investigation to ascertain compliance with such rules, regulations, and orders.

F. In the event of the Contractor's noncompliance with the nondiscrimination clauses of this contract or with any of the said rules, regulations, or orders, this contract may be canceled, terminated, or suspended in whole or in part and the Contractor may be declared ineligible for further Government contracts or federally assisted construction contracts in accordance with procedures authorized in Executive Order 11246 of September 24, 1965, and such other sanctions may be imposed and remedies invoked as provided in Executive Order 11246 of September 24, 1965, or by rule, regulation, or order of the Secretary of Labor, or as otherwise provided by law.

G. The Contractor will include the portion of the sentence immediately preceding paragraph (1) and the provisions of paragraphs (1) through (7) in every subcontract or purchase order unless exempted by rules, regulations, or orders of the Secretary of Labor issued pursuant to section 204 of Executive Order 11246 of September 24, 1965, so that such provisions will be binding

upon each subcontractor or vendor. The Contractor will take such action with respect to any subcontract or purchase order as the administering agency may direct as a means of enforcing such provisions, including sanctions for noncompliance: *Provided, however*, that in the event the Contractor becomes involved in, or is threatened with, litigation with a subcontractor or vendor as a result of such direction by the administering agency the Contractor may request the United States to enter into such litigation to protect the interests of the United States.

*H. Subcontracts.* Each nonexempt prime contractor or subcontractor shall include the equal opportunity clause in each of its nonexempt subcontracts.

*I. Incorporation by reference.* The equal opportunity clause may be incorporated by reference in all Government contracts and subcontracts, including Government bills of lading, transportation requests, contracts for deposit of Government funds, and contracts for issuing and paying U.S. savings bonds and notes, and such other contracts and subcontracts as the Deputy Assistant Secretary may designate.

*J. Incorporation by operation of the order.* By operation of the order, the equal opportunity clause shall be considered to be a part of every contract and subcontract required by the order and the regulations in this part to include such a clause whether or not it is physically incorporated in such contracts and whether or not the contract between the agency and the contractor is written.

*K. Adaptation of language.* Such necessary changes in language may be made in the equal opportunity clause as shall be appropriate to identify properly the parties and their undertakings. [43 FR 49240, Oct. 20, 1978, as amended at 62 FR 66971, Dec. 22, 1997]

## **2. EQUAL EMPLOYMENT OPPORTUNITY REPORTS AND OTHER REQUIRED INFORMATION**

### *A. Requirements for prime contractors and subcontractors.*

1. Each prime contractor and subcontractor shall file annually, on or before the September 30, complete and accurate reports on Standard Form 100 (EEO-1) promulgated jointly by the Office of Federal Contract Compliance Programs, the Equal Employment Opportunity Commission and Plans for Progress or such form as may hereafter be promulgated in its place if such prime contractor or subcontractor (i) is not exempt from the provisions of these regulations in accordance with § 60-1.5; (ii) has 50 or more employees; (iii) is a prime contractor or first tier subcontractor; and (iv) has a contract, subcontract or purchase order amounting to \$50,000 or more or serves as a depository of Government funds in any amount, or is a financial institution which is an issuing and paying agent for U.S. savings bonds and savings notes: *Provided*, That any subcontractor below the first tier which performs construction work at the site of construction shall be required to file such a report if it meets requirements of paragraphs (a)(1) (i), (ii), and (iv) of this section.

2. Each person required by § 60-1.7(a)(1) to submit reports shall file such a report with the contracting or administering agency within 30 days after the award to him of a contract or subcontract, unless such person has submitted such a report within 12 months preceding the date of the award. Subsequent reports shall be submitted annually in accordance with § 60-1.7(a)(1), or at such other intervals as the Deputy Assistant

Secretary may require. The Deputy Assistant Secretary may extend the time for filing any report.

3. The Deputy Assistant Secretary or the applicant, on their own motions, may require a contractor to keep employment or other records and to furnish, in the form requested, within reasonable limits, such information as the Deputy Assistant Secretary or the applicant deems necessary for the administration of the order.

4. Failure to file timely, complete and accurate reports as required constitutes noncompliance with the prime contractor's or subcontractor's obligations under the equal opportunity clause and is ground for the imposition by the Deputy Assistant Secretary, an applicant, prime contractor or subcontractor, of any sanctions as authorized by the order and the regulations in this part.

*B. Requirements for bidders or prospective contractors—*

*1. Certification of compliance with Part 60-2: Affirmative Action Programs.* Each agency shall require each bidder or prospective prime contractor and proposed subcontractor, where appropriate, to state in the bid or in writing at the outset of negotiations for the contract: (i) Whether it has developed and has on file at each establishment affirmative action programs pursuant to Part 60-2 of this chapter; (ii) whether it has participated in any previous contract or subcontract subject to the equal opportunity clause; (iii) whether it has filed with the Joint Reporting Committee, the Deputy Assistant Secretary or the Equal Employment Opportunity Commission all reports due under the applicable filing requirements.

*2. Additional information.* A bidder or prospective prime contractor or proposed subcontractor shall be required to submit such information as the Deputy Assistant Secretary requests prior to the award of the contract or subcontract. When a determination has been made to award the contract or subcontract to a specific contractor, such contractor shall be required, prior to award, or after the award, or both, to furnish such other information as the applicant or the Deputy Assistant Secretary requests.

*C. Use of reports.* Reports filed pursuant to this section shall be used only in connection with the administration of the order, the Civil Rights Act of 1964, or in furtherance of the purposes of the order and said Act.[43 FR 49240, Oct. 20, 1978, as amended at 62 FR 66971, Dec. 22, 1997]

**3. RESERVED (DAVIS-BACON WAGES DO NOT APPLY)**

**4. CONTRACT WORK HOURS AND SAFETY STANDARDS (from FAR 52.222-4)**

The term "Contracting Officer" herein shall refer to the City of Colorado Springs Contracting Specialist assigned to this contract.

The term "Government" herein shall refer to the City of Colorado Springs and any interested federal or state entity.

*A. Overtime requirements.* No Contractor or subcontractor employing laborers or mechanics (see Federal Acquisition Regulation 22.300) shall require or permit them to work over 40 hours

in any workweek unless they are paid at least 1 and 1/2 times the basic rate of pay for each hour worked over 40 hours.

*B. Violation; liability for unpaid wages; liquidated damages.* The responsible Contractor and subcontractor are liable for unpaid wages if they violate the terms in paragraph (a) of this clause. In addition, the Contractor and subcontractor are liable for liquidated damages payable to the Government. The Contracting Officer will assess liquidated damages at the rate of \$10 per affected employee for each calendar day on which the employer required or permitted the employee to work in excess of the standard workweek of 40 hours without paying overtime wages required by the Contract Work Hours and Safety Standards statute (found at 40 U.S.C. chapter 37).

*C. Withholding for unpaid wages and liquidated damages.* The Contracting Officer will withhold from payments due under the contract sufficient funds required to satisfy any Contractor or subcontractor liabilities for unpaid wages and liquidated damages. If amounts withheld under the contract are insufficient to satisfy Contractor or subcontractor liabilities, the Contracting Officer will withhold payments from other Federal or federally assisted contracts held by the same Contractor that are subject to the Contract Work Hours and Safety Standards statute

*D. Payrolls and basic records.*

1. The Contractor and its subcontractors shall maintain payrolls and basic payroll records for all laborers and mechanics working on the contract during the contract and shall make them available to the Government until 3 years after contract completion. The records shall contain the name and address of each employee, social security number, labor classifications, hourly rates of wages paid, daily and weekly number of hours worked, deductions made, and actual wages paid. The records need not duplicate those required for construction work by Department of Labor regulations at 29 CFR 5.5(a)(3) implementing the Construction Wage Rate Requirements statute.

2. The Contractor and its subcontractors shall allow authorized representatives of the Contracting Officer or the Department of Labor to inspect, copy, or transcribe records maintained under paragraph (d)(1) of this clause. The Contractor or subcontractor also shall allow authorized representatives of the Contracting Officer or Department of Labor to interview employees in the workplace during working hours.

*E. Subcontracts.* The Contractor shall insert the provisions set forth in paragraphs (a) through (d) of this clause in subcontracts that may require or involve the employment of laborers and mechanics and require subcontractors to include these provisions in any such lower tier subcontracts. The Contractor shall be responsible for compliance by any subcontractor or lower-tier subcontractor with the provisions set forth in paragraphs (a) through (d) of this clause.

## **5. CLEAN AIR ACT**

By signing this Contract, the Contractor agrees to comply with all applicable standards, orders, or regulations issued pursuant to the Clean Air Act (42 U.S.C. 7401-7671q) and the Federal Water Pollution Control Act as amended (33 U.S.C. 1251-1387). Violations must be reported to the Federal awarding agency and the Regional Office of the Environmental Protection Agency (EPA). Further, the Contractor agrees to include this clause in all subcontracts in excess of \$150,000.

## **6. DEBARMENT AND SUSPENSION**

By signing this Contract, the Contractor certifies to the best of its knowledge and belief that it and its principals:

- A. Are not presently debarred, suspended, proposed for debarment, declared ineligible, or voluntarily excluded from covered transactions by any Federal department or agency;
- B. Have not within a three year period preceding this proposal been convicted of or had a civil judgment rendered against them for commission of fraud or a criminal offense in connection with obtaining, attempting to obtain, or performing a public (Federal, State, or local) transaction or contract under a public transaction; violation of Federal or State antitrust statutes or commission of embezzlement, theft, forgery, falsification or destruction of records, making false statements, or receiving stolen property;
- C. Are not presently indicted for or otherwise criminally or civilly charged by a government entity (Federal, State, or local) with commission of any of the offenses enumerated in paragraph (1)(b) of this certification; and
- D. Have not within a three-year period preceding this application/proposal had one or more public transactions (Federal, State, or local) terminated for cause or default.

## **7. BYRD ANTI-LOBBYING AMENDMENT**

By signing this Contract, the Contractor certifies that it will not and has not used Federal appropriated funds to pay any person or organization for influencing or attempting to influence an officer or employee of any agency, a member of Congress, officer or employee of Congress, or an employee of a member of Congress in connection with obtaining any Federal contract, grant or any other award covered by 31 U.S.C. 1352. Further, the Contractor certifies that it has not engaged in lobbying with non-Federal funds that takes place in connection with obtaining any Federal award. The Contractor must require the same certification from all subcontractors with subcontracts valued in excess of \$100,000 under this Contract.

## **8. SMALL BUSINESS REQUIREMENTS**

The Contractor must take all necessary affirmative steps to assure that minority businesses, women's business enterprises, and labor surplus area firms are used when possible.

Affirmative steps must include:

- A. Placing qualified small and minority businesses and women's business enterprises on subcontract solicitation lists.
- B. Assuring that small and minority businesses, and women's business enterprises are solicited whenever they are potential sources for subcontracting.
- C. Dividing total requirements, when economically feasible, into smaller tasks or quantities to permit maximum participation by small and minority businesses, and women's business enterprises.

D. Establishing delivery schedules, where the requirement permits, which encourage participation by small and minority businesses, and women's business enterprises.

E. Using the services and assistance, as appropriate, of such organizations as the Small Business Administration and the Minority Business Development Agency of the Department of Commerce.

## **9. PROCUREMENT OF RECOVERED MATERIALS**

The Contractor must comply with section 6002 of the Solid Waste Disposal Act, as amended by the Resource Conservation and Recovery Act. The requirements of Section 6002 include procuring only items designated in guidelines of the Environmental Protection Agency (EPA) at 40 CFR part 247 that contain the highest percentage of recovered materials practicable, consistent with maintaining a satisfactory level of competition, where the purchase price of the item exceeds \$10,000 or the value of the quantity acquired by the preceding fiscal year exceeded \$10,000; procuring solid waste management services in a manner that maximizes energy and resource recovery; and establishing an affirmative procurement program for procurement of recovered materials identified in the EPA guidelines.

## **10. ANTI-KICKBACK PROCEDURES**

A. Definitions.

1. "Kickback," as used in this clause, means any money, fee, commission, credit, gift, gratuity, thing of value, or compensation of any kind which is provided to any prime Contractor, prime Contractor employee, subcontractor, or subcontractor employee for the purpose of improperly obtaining or rewarding favorable treatment in connection with a prime contract or in connection with a subcontract relating to a prime contract.
2. "Person," as used in this clause, means a corporation, partnership, business association of any kind, trust, joint-stock company, or individual.
3. "Prime contract," as used in this clause, means a contract or contractual action entered into by the United States for the purpose of obtaining supplies, materials, equipment, or services of any kind.
4. "Prime Contractor" as used in this clause, means a person who has entered into a prime contract with the United States.
5. "Prime Contractor employee," as used in this clause, means any officer, partner, employee, or agent of a prime Contractor.
6. "Subcontract," as used in this clause, means a contract or contractual action entered into by a prime Contractor or subcontractor for the purpose of obtaining supplies, materials, equipment, or services of any kind under a prime contract.
7. "Subcontractor," as used in this clause,
  - a. Means any person, other than the prime Contractor, who offers to furnish or furnishes any supplies, materials, equipment, or services of any kind under a

prime contract or a subcontract entered into in connection with such prime contract, and

b. Includes any person who offers to furnish or furnishes general supplies to the prime Contractor or a higher tier subcontractor.

8. "Subcontractor employee," as used in this clause, means any officer, partner, employee, or agent of a subcontractor.

B. The 41 U.S.C. chapter 87, Kickbacks, prohibits any person from --

1. Providing or attempting to provide or offering to provide any kickback;
2. Soliciting, accepting, or attempting to accept any kickback; or
3. Including, directly or indirectly, the amount of any kickback in the contract price charged by a prime Contractor to the United States or in the contract price charged by a subcontractor to a prime Contractor or higher tier subcontractor.

C. The Contractor shall have in place and follow reasonable procedures designed to prevent and detect possible violations described in paragraph (b) of this clause in its own operations and direct business relationships.

When the Contractor has reasonable grounds to believe that a violation described in paragraph (b) of this clause may have occurred, the Contractor shall promptly report in writing the possible violation. Such reports shall be made to the inspector general of the contracting agency, the head of the contracting agency if the agency does not have an inspector general, or the Attorney General.

The Contractor shall cooperate fully with any Federal agency investigating a possible violation described in paragraph (b) of this clause.

The Contracting Officer may

1. offset the amount of the kickback against any monies owed by the United States under the prime contract and/or
2. direct that the Prime Contractor withhold from sums owed a subcontractor under the prime contract the amount of the kickback. The Contracting Officer may order that monies withheld under subdivision (c)(4)(ii) of this clause be paid over to the Government unless the Government has already offset those monies under subdivision (c)(4)(i) of this clause. In either case, the Prime Contractor shall notify the Contracting Officer when the monies are withheld.

The Contractor agrees to incorporate the substance of this clause, including subparagraph (c)(5) but excepting subparagraph (c)(1), in all subcontracts under this contract which exceed \$150,000.

## **11. ENERGY EFFICIENCY IN ENERGY CONSUMING PRODUCTS**

A. Definition. As used in this clause--



1. “Energy-efficient product”—

a. Means a product that—

- i. Meets Department of Energy and Environmental Protection Agency criteria for use of the Energy Star trademark label; or
- ii. Is in the upper 25 percent of efficiency for all similar products as designated by the Department of Energy’s Federal Energy Management Program.

2. The term “product” does not include any energy-consuming product or system designed or procured for combat or combat-related missions (42 U.S.C. 8259b).

B. The Contractor shall ensure that energy-consuming products are energy efficient products (i.e., ENERGY STAR® products or FEMP-designated products) at the time of contract award, for products that are—

1. Delivered.

2. Acquired by the Contractor for use in performing services at a Federally controlled facility.

3. Furnished by the Contractor for use by the Government.

4. Specified in the design of a building or work, or incorporated during its construction, renovation, or maintenance.

C. The requirements of paragraph (b) apply to the Contractor (including any subcontractor) unless:

1. The energy-consuming product is not listed in the ENERGY STAR® Program or FEMP; or

2. Otherwise approved in writing by the Contracting Officer.

D. Information about these products is available for—

1. ENERGY STAR® at <http://www.energystar.gov/products>; and

2. FEMP at [http://www1.eere.energy.gov/femp/procurement/eep\\_requirements.html](http://www1.eere.energy.gov/femp/procurement/eep_requirements.html).

## 12. BUY AMERICAN—CONSTRUCTION MATERIALS

A. Definitions. As used in this clause—

1. “Commercially available off-the-shelf (COTS) item”—

a. Means any item of supply (including construction material) that is—

- i. A commercial item (as defined in paragraph (1) of the definition at FAR [2.101](#));
    - ii. Sold in substantial quantities in the commercial marketplace; and
    - iii. Offered to the Government, under a contract or subcontract at any tier, without modification, in the same form in which it is sold in the commercial marketplace; and
  - b. Does not include bulk cargo, as defined in [46 U.S.C. 40102\(4\)](#), such as agricultural products and petroleum products.
- 2. “Component” means an article, material, or supply incorporated directly into a construction material.
- 3. “Construction material” means an article, material, or supply brought to the construction site by the Contractor or a subcontractor for incorporation into the building or work. The term also includes an item brought to the site preassembled from articles, materials, or supplies. However, emergency life safety systems, such as emergency lighting, fire alarm, and audio evacuation systems, that are discrete systems incorporated into a public building or work and that are produced as complete systems, are evaluated as a single and distinct construction material regardless of when or how the individual parts or components of those systems are delivered to the construction site. Materials purchased directly by the Government are supplies, not construction material.
- 4. “Cost of components” means—
  - a. For components purchased by the Contractor, the acquisition cost, including transportation costs to the place of incorporation into the construction material (whether or not such costs are paid to a domestic firm), and any applicable duty (whether or not a duty-free entry certificate is issued); or
  - b. For components manufactured by the Contractor, all costs associated with the manufacture of the component, including transportation costs as described in paragraph (1) of this definition, plus allocable overhead costs, but excluding profit. Cost of components does not include any costs associated with the manufacture of the construction material.
- 5. “Domestic construction material” means—
  - a. An unmanufactured construction material mined or produced in the United States;
  - b. A construction material manufactured in the United States, if—
    - i. The cost of its components mined, produced, or manufactured in the United States exceeds 50 percent of the cost of all its components. Components of foreign origin of the same class or kind for which nonavailability determinations have been made are treated as domestic.
    - b. The construction material is a COTS item.

6. "Foreign construction material" means a construction material other than a domestic construction material.

7. "United States" means the 50 States, the District of Columbia, and outlying areas.

a. Domestic preference.

i. This clause implements [41 U.S.C. chapter 83](#), Buy American, by providing a preference for domestic construction material. In accordance with [41 U.S.C. 1907](#), the component test of the Buy American statute is waived for construction material that is a COTS item. (See FAR [12.505\(a\)\(2\)](#)). The Contractor shall use only domestic construction material in performing this contract, except as provided in paragraphs (b)(2) and (b)(3) of this clause.

ii. This requirement does not apply to information technology that is a commercial item or to the construction materials or components listed by the Government as follows:

b. The Contracting Officer may add other foreign construction material to the list in paragraph (b)(2) of this clause if the Government determines that—

i. The cost of domestic construction material would be unreasonable. The cost of a particular domestic construction material subject to the requirements of the Buy American statute is unreasonable when the cost of such material exceeds the cost of foreign material by more than 6 percent;

ii. The application of the restriction of the Buy American statute to a particular construction material would be impracticable or inconsistent with the public interest; or

iii. The construction material is not mined, produced, or manufactured in the United States in sufficient and reasonably available commercial quantities of a satisfactory quality.

8. Request for determination of inapplicability of the Buy American statute.

a. Any Contractor request to use foreign construction material in accordance with paragraph (b)(3) of this clause shall include adequate information for Government evaluation of the request, including—

i. A description of the foreign and domestic construction materials

ii. Unit of measure

iii. Quantity

iv. Price

v. Time of delivery or availability

vi. Location of the construction project

vii. Name and address of the proposed supplier

viii. A detailed justification of the reason for use of foreign construction materials cited in accordance with paragraph (b)(3) of this clause.

- b. A request based on unreasonable cost shall include a reasonable survey of the market and a completed price comparison table in the format in paragraph (d) of this clause.
- (iii) The price of construction material shall include all delivery costs to the construction site and any applicable duty (whether or not a duty-free certificate may be issued).
- (iv) Any Contractor request for a determination submitted after contract award shall explain why the Contractor could not reasonably foresee the need for such determination and could not have requested the determination before contract award. If the Contractor does not submit a satisfactory explanation, the Contracting Officer need not make a determination.

(2) If the Government determines after contract award that an exception to the Buy American statute applies and the Contracting Officer and the Contractor negotiate adequate consideration, the Contracting Officer will modify the contract to allow use of the foreign construction material. However, when the basis for the exception is the unreasonable price of a domestic construction material, adequate consideration is not less than the differential established in paragraph (b)(3)(i) of this clause.

(3) Unless the Government determines that an exception to the Buy American statute applies, use of foreign construction material is noncompliant with the Buy American statute.

(d) Data. To permit evaluation of requests under paragraph (c) of this clause based on unreasonable cost, the Contractor shall include the following information and any applicable supporting data based on the survey of suppliers:

**FOREIGN AND DOMESTIC CONSTRUCTION MATERIALS PRICE COMPARISON**

Construction Material Description	Unit of Measure	Quantity	Price (Dollars)*
Item 1:			
Foreign construction material	_____	_____	_____
Domestic construction material	_____	_____	_____
Item 2:			
Foreign construction material	_____	_____	_____
Domestic construction material	_____	_____	_____

[List name, address, telephone number, and contact for suppliers surveyed. Attach copy of response; if oral, attach summary.]

[Include other applicable supporting information.]

[\* Include all delivery costs to the construction site and any applicable duty (whether or not a duty-free entry certificate is issued).]

**13. INFRASTRUCTURE INVESTMENT AND JOBS ACT, BUILD AMERICA, BUY AMERICA**

**THIS SECTION ONLY APPLIES TO PROJECTS THAT HAVE A TOTAL COST OF \$250,000**

**OR MORE AND THAT INCLUDE THE USE OF IRON OR STEEL.**

Recipients of an award of Federal financial assistance from a program for infrastructure are hereby notified that none of the funds provided under this Agreement may be used for a project for infrastructure unless:

A. All iron and steel used in the PROJECT are produced in the United States--this means all manufacturing processes, from the initial melting stage through the application of coatings, occurred in the United States.

B. All manufactured products used in the PROJECT are produced in the United States—this means the manufactured product was manufactured in the United States; and the cost of the components of the manufactured product that are mined, produced, or manufactured in the United States is greater than 55 percent of the total cost of all components of the manufactured product, unless another standard for determining the minimum amount of domestic content of the manufactured product has been established under applicable law or regulation.

C. All construction materials (excludes cement and cementitious materials, aggregates such as stone, sand, or gravel, or aggregate binding agents or additives) are manufactured in the United States—this means that all manufacturing processes for the construction material occurred in the United States.

D. The Buy America preference only applies to articles, materials, and supplies that are consumed in, incorporated into, or affixed to an infrastructure project. As such, it does not apply to tools, equipment, and supplies, such as temporary scaffolding, brought to the construction site and removed at or before the completion of the infrastructure project. Nor does a Buy America preference apply to equipment and furnishings, such as movable chairs, desks, and portable computer equipment, that are used at or within the finished infrastructure project but are not an integral part of the structure or permanently affixed to the infrastructure project.

E. Definitions:

“Construction materials” includes an article, material, or supply—other than an item of primarily iron or steel; a manufactured product; cement and cementitious materials; aggregates such as stone, sand, or gravel; or aggregate binding agents or additives 46—that is or consists primarily of:

1. Non-ferrous metals
2. Plastic and polymer-based products (including polyvinyl/chloride, composite building materials, and polymers used in fiber optic cables)
3. Glass (including optic glass)
4. Lumber; or drywall



**SCHEDULE F – PROJECT SPECIFICATIONS**

**FOLLOWS THIS PAGE**

# 300 South Union Boulevard Memorial Park War Memorial

Martin/Martin, Inc. Project No.: 24.0871.S.01

---

## Structural Specifications

August 27, 2024



## TABLE OF CONTENTS

09965	TRANSLUCENT SILICONE COATING	GE Silicones
SC-203-03/10	CONCRETE	Sika Concrete Restoration Systems





Product Guide Specification  
SECTION 09965  
TRANSLUCENT SILICONE COATING

**PART 1 GENERAL**

The purpose of this specification is to provide general information and to discuss how to apply GE Optic\* Translucent Silicone Coating. ***This information herein is not intended to replace the expertise of a professional industry consultant / inspector who is qualified in the restoration and the forensic investigation of buildings.***

**1.1 SECTION INCLUDES**

- A. Silicone Elastomeric Coating.

**1.2 RELATED SECTIONS**

- A. Section 09910 - Paints.
- B. Section 09960 - High-Performance Coatings.

**1.3 REFERENCES**

- A. ASTM D 412 - Vulcanized Rubber and Thermoplastic Rubbers and Thermoplastic Elastomers - Tension.
- B. ASTM D 2240 - Rubber Property - Durometer Hardness.

**1.4 SUBMITTALS**

- A. Comply with Section 01330 - Submittal Procedures.
- B. Product Data: Submit manufacturer's product data, including surface preparation and application.
- C. Color Samples: Submit manufacturer's translucent samples.
- D. Manufacturer's Review: Submit manufacturer's review that proposed materials are suitable for intended application.
- E. Warranty: Submit manufacturer's standard warranty.

**1.5 QUALITY ASSURANCE**



- A. Mock-Ups:
  - 1. Prepare field mock-up of coating for each type of surface using same materials, tools, equipment, and procedures intended for actual surface preparation and application under actual use and environmental conditions.
  - 2. Verify effectiveness of surface preparation.
  - 3. Verify performance of coating.
  - 4. Verify coating adhesion to substrate(s).
  - 5. Invite the attendance of Contractor, Architect, Applicator, Manufacturer's representative and other relevant parties to observe preparation of mock-ups and to witness adhesion test.
  - 6. Obtain Architect, Owner, Consultant, or other authorized representative's approval of mock-ups.
  - 7. Retain mock-ups to establish intended standards by which coating will be evaluated.
  
- B. Pre-application Meeting: Convene a pre-application meeting two [2] [\_\_\_\_\_] weeks or as required by architect, owners agent or consultant before start of application of coating. Invite attendance of parties directly affecting work of this section, including Contractor, Architect, Applicator, and Manufacturer's Representative. Review examination, surface preparation, application, field quality control, cleaning, protection, and coordination with other work.

## 1.6 DELIVERY, STORAGE, AND HANDLING

- A. Delivery: Deliver materials to site in manufacturer's original, unopened containers and packaging, with labels clearly identifying:
  - 1. Product name.
  - 2. Manufacturer.
  - 3. Color.
  - 4. Batch or lot number.
  - 5. Date of manufacture.
  - 6. Use-before date.
  
- B. Storage:
  - 1. Store materials in a clean, dry area indoors in accordance with manufacturer's instructions.
  - 2. Store materials within temperature range in accordance with manufacturer's instructions.
  - 3. Keep containers sealed until ready for use.
  - 4. Do not use materials after manufacturer's use-before date.
  
- C. Handling: Protect materials from damage and contamination during handling and application.

## 1.7 ENVIRONMENTAL REQUIREMENTS



- A. Application is not recommended when the temperature is below 20° F (-7° C) or if frost or moisture is present on the surfaces to be coated. Refer to the Momentive Performance Materials (MPM) Technical bulletin "Cold Weather Installation Guidelines" for additional information.
- B. Application not recommended to surfaces above 120° F (49° C). The time to complete cure of this product is dependent upon temperature and humidity. Under basic conditions [72 °F (22° C) and 50% RH] this material can attain a tack-free surface in 1-2 hours. As temperatures drop towards freezing, application should proceed with caution due to the possibility of moisture (dew, frost) on surfaces to be coated as well as longer curing times relative to application of a second or touchup coat (recoat), (and vice versa as temperatures increase).
- C. When spraying Optic coating in windy conditions, take precautionary measures to avoid excessive overspray. It is suggested to withhold spraying when wind speeds exceed 10 mph.
- D. Prior to application, ensure that a minimum of 4 hours of adequate temperature and cure time are available when inclement weather is predicted. Contact Momentive technical services for additional time-related precautionary measures when application is proceeding under winter temperatures and conditions.

## 1.8 WARRANTY

- A. General: Manufacturer's standard project-specific form in which manufacturer agrees to repair or replace architectural coating that demonstrates deterioration or failure within warranty period specified due to material failure under normal use.
  - 1. Warranty Period: *fifteen (15)* years from date of Substantial Completion.

## PART 2 PRODUCTS

### 2.1 MANUFACTURER

- A. Momentive Performance Materials, 260 Hudson River Road Waterford, NY 12188. Web Site [www.siliconeforbuilding.com](http://www.siliconeforbuilding.com)

### 2.2 SILICONE ELASTOMERIC COATING

- A. Basis of design Coating: GE Optic 3101 Translucent Silicone Coating.
- B. Description: One-component, elastomeric, silicone, high-solids, UV resistant, coating.
- C. Properties, As Supplied:
  - 1. Density (lb/gal), WPSTM P 14: 8.17 pounds per gallon (.97 g/ml).
  - 2. Solids Content, By Volume, WPSTM C 19: 73 percent.



## GE Silicones

3. Solids Content, By Weight, WPSTM C 19: 70 percent.
  4. Tack-Free Time, WPSTM E 86: 1 to 2 hours.
  5. Skin-Over Time: <30 minutes.
  6. Viscosity, WPSTM C 560: 5,000 centipoises
  7. Volatile Organic Content (VOC), EPA Method 24: 24 g/L.
- D. Properties, As Cured:
1. Tensile Strength, ASTM D 412: 121 psi.
  2. Elongation, ASTM D 412: 200 percent.
  3. Vapor Permeance (10 Mils DFT) ASTM E 96 Wet Cup: 18 perms.
  4. Wind Driven Rain Resistance, ASTM D6904: Pass.
- E. Color: [Translucent].
- F. Primer: If necessary based on adhesion testing. Compatible with surfaces and coating. Approved by manufacturer. Most GE Optic coating applications do not require the use of a primer. Verify coating adhesion to substrate as specified under Field Quality Control in Section 3.4.

### **PART 3 EXECUTION**

#### **3.1 EXAMINATION**

- A. Examine surfaces to receive coating. Notify Architect/Consultant or owner's representative if conditions are not acceptable. Do not begin surface preparation or application until unacceptable conditions have been corrected.

#### **3.2 SURFACE PREPARATION**

- A. Prepare surfaces in accordance with manufacturer's instructions.
- B. Remove dirt, dust, oil, grease, rust, mildew, chalk, efflorescence, concrete laitance, concrete form release agents, concrete curing compounds, loose particles, other bond breaking contaminants, and unsound materials.
- C. Solvents shall not be used on concrete without consulting with Momentive Technical Services. Concrete must be free of release agents, curing compounds, or other adhesion inhibiting contaminants.
- D. Allow concrete and mortar to cure for a minimum of 30 days before coating.
- E. Fill cracks and holes with approved patching materials and sand smooth.



## GE Silicones

1. All cracks greater than hairline width, approximately 0.8 mm (1/32 inch), must be ground out and patched with sealant or appropriate patching compound. Alternatively, cracks may be sealed by brushing in optic coating. Sealant or patching compound repairs should match the substrate color and texture as closely as possible.
  2. Structural cracks of any thickness must be repaired with approved material and stabilized to prevent movement.
- F. Protect surrounding areas and surfaces not intended to be coated from damage during surface preparation and application.
1. Misapplied uncured or partially cured coating on non-porous surfaces shall be removed by wiping with dry cloths, or cloths wet with mineral spirits followed by dry cloths. Cured coating may be removed from nonporous surfaces such as glass or metal by razor scraping. Removal from porous surfaces such as stone, concrete or wood should be attempted as described above for nonporous surfaces. It may be necessary to abrade, sandblast or sand the cleaned porous surface to remove all traces of coating residue. Plants and animal life should be removed from exposure or provided with positive protection from overspray or misapplication of coating.
  2. Removal of misapplied coatings is the responsibility of the applicator.
  3. After the coating is applied, the contractor shall remove all masking and other protection and clean up any remaining defacement caused by this work.

### 3.3 APPLICATION

- A. Ensure surfaces to receive coating are clean, dry, structurally sound, and free of frost and frozen materials. As temperatures drop towards freezing, application should proceed with caution due to the possibility of moisture (dew, frost) on surfaces to be coated as well as longer curing times relative to application of a second or touchup coat (recoat).
- B. Apply uniform, pinhole-free coating in two (2) separate coats at spreading rate required to achieve a total minimum dry film thickness of 0.010 inch (10 mils/254 microns). Apply coating in accordance with manufacturer's instructions.
1. Each application should be applied at a wet thickness per coat of 0.07 inches (7 mils/177 microns). Wet coating thickness may be estimated by using a wet film thickness gauge. Maximum calculated theoretical coverage per coat is 234 ft<sup>2</sup>/gallon. A mockup must be applied to determine the actual coverage rate per gallon needed to provide a pinhole free film at the minimum required dry film thickness.
  2. The second coat may be applied when the first coat is tack free to the touch. A tack free condition will usually take at least one (1) hour at 70-80° F (21-27 ° C). (Cooler temperatures will require more time. While cured to the touch, the coating will typically take 3-7 days to achieve final physical properties.



3. Apply coating from top to bottom of substrate. Work down the vertical surface and cover any rundown in the process. Avoid excessive overlapping.
  4. Apply architectural coating as closely as possible to a consistent film thickness free of cloudiness, spotting, laps, brush marks, roller tracks, and other surface imperfections. Cut in breaks and terminations with sharp lines.
  5. Apply additional coats as required to provide cured film with uniform coverage, finish, and appearance.
- C. Do not dilute coating without consulting with Momentive Technical Services.
- D. Keep containers closed when not in use to avoid contamination.
- E. Apply primer, if required, in accordance with manufacturer's instructions. Allow primer to dry before applying coating.
- F. Avoid over spray of coating. Over spray and misapplied coating should be removed immediately in accordance with manufacturer's instructions while it is still uncured. Repair or replace surfaces damaged by overspray or misapplied coating as determined by Architect.

### 3.4 FIELD QUALITY CONTROL

- A. Verify total dry film thickness of applied coating in accordance with specified requirements using a dry film gauge. Coating thickness may be verified by measuring the thickness of the cured coating piece with a micrometer.
- B. Visually assess coating for film characteristics or defects that would adversely affect performance or appearance.
- C. Verify coating adhesion to substrate following full cure.
1. After substrate preparation, apply one coat at 6-8 wet mils in an unobtrusive area.
  2. While the coating is still wet, embed a 1" x 6" length of mesh screen / piece of gauze into the coating leaving an approximate 2" tab accessible for hand pull. Allow product to become tack-free.
  3. Once the first coat is tack-free, apply a second coat at 6-8 wet mils over the mesh screen / gauze. Allow product to cure for 72 hours before performing adhesion testing.
  4. Grasp the mesh screen / gauze tab and pull it away from the surface at a 90-degree angle. Pull until it tears cohesively (or releases from the surface) and photograph / document results. Good adhesion will be evidenced by breaking of coating film. Touch up adhesion test area with more coating.
  5. Refer to Momentive Technical Services for any questions
- D. Correct nonconforming work.



**3.5 CLEANING**

- A. Remove temporary coverings and protection of surrounding areas and surfaces.

**3.6 PROTECTION**

- A. Protect applied coating from rain or damage until tack free.

**END OF SECTION**

## **DIVISION 3 – CONCRETE**

### **Section -**

### **Part 1 – General**

#### **1.01 Summary**

- A. This specification describes the treatment of concrete surfaces with a penetrating corrosion inhibitor to reduce the effects of corrosion in reinforced concrete.

#### **1.02 Quality Assurance**

- A. Manufacturing qualifications: The manufacturer of the specified product shall be ISO 9001 certified and have in existence a recognized ongoing quality assurance program independently audited on a regular basis.
- B. Contractor qualifications: Contractor shall be qualified in the field of concrete repair and protection with a successful track record of 5 years or more. Contractor shall maintain qualified personnel who have received product training by a manufacturer's representative
- C. Install materials in accordance with all safety and weather conditions required by manufacturer or as modified by applicable rules and regulations of local, state and federal authorities having jurisdiction. Consult Material Safety Data Sheets for complete handling recommendations.
- D. Manufacturer must be capable of testing on-site for the presence of the corrosion inhibitor at the specified depth.

#### **1.03 Delivery, Storage, and Handling**

- A. All materials must be delivered in original, unopened containers with the manufacturer's name, labels, product identification, and batch numbers. Damaged material must be removed from the site immediately.
- B. Store all materials off the ground and protect from rain, freezing or excessive heat until ready for use.
- C. Condition the specified product as recommended by the manufacturer.

#### **1.04 Job Conditions**

- A. Environmental Conditions: Do not apply material if it is raining or snowing or if such conditions appear to be imminent. Minimum application temperature 35°F (2°C) and rising.
- B. Protection: Precautions should be taken to avoid damage to any surface near the work zone due to mixing and handling of the specified material.

#### **1.05 Submittals**

- A. Submit two copies of manufacturer's literature, to include: Product Data Sheets, and appropriate Material Safety Data Sheets (MSDS).
- B. Corrosion rate field monitoring using linear polarization resistance by an independent, qualified monitoring and management company demonstrating an ability to reduce corrosion rates by a minimum of 65%.
- C. Proof of compliance with the properties specified in Section 2.03 Performance Criteria.

#### **1.06 Warranty**

- A. Provide a written warranty from the manufacturer against defects of materials for a period of one (1) year, beginning with date of substantial completion of the project.



## Part 2 - Products

### 2.01 Manufacturer

- A. **Sika FerroGard 903**, as manufactured by Sika Corporation, is considered to conform to the requirements of this specification.

### 2.02 Materials

- A. General: Penetrating corrosion inhibiting impregnation coating
  1. The material shall be a organic and inorganic in nature and environmentally safe.
  2. The materials shall be water based.
  3. The materials shall be not contain calcium nitrite.
  4. The material shall not form a vapor barrier.
  5. The material shall be a mixed inhibitor.

### 2.03 Performance Criteria

- A. Typical Properties of the penetrating corrosion inhibiting impregnation coating::
  1. Viscosity (Brookfield Viscometer, Spindle #1, Speed 100) 15 cps.
  2. Color: Pale Yellow
  3. Density: 1.13 (9.4 lbs./ gal.)
  4. PH: 11 (+/-1)
  5. Flash point: None (water-based)
- B. Corrosion testing of penetrating corrosion inhibiting impregnation coating::
  1. The material must form a continuous film on the reinforcing steel and displace chlorides ions from the steel surface (X-ray Photon Spectroscopy (XPS) and Secondary Ion Mass Spectroscopy (SIMS).
  2. The material must penetrate independently of orientation (horizontal, vertical, overhead) at a rate up to 1/10 to 4/5 inches (2.5 to 20 mm) per day, depending on density of concrete. (Secondary Neutron Mass Spectroscopy (SNMS).
  3. The material must have demonstrated the reduction in corrosion currents after treatment as calculated by the Cracked Beam Corrosion Tests of concrete. (Adapted from ASTM G 109)
  4. The material must form a protective layer on the reinforcing steel of high integrity measured at 100A thickness. (X-ray Photon Spectroscopy and Secondary ion Mass Spectroscopy).
  5. The material must penetrate up to 3 inches (76 mm) in 28 days. (Secondary Neutron Mass Spectroscopy).
  6. The material must be capable of reducing active corrosion rates by a minimum of 65%. This reduction shall be demonstrated by project references and an independent corrosion engineer using linear polarization resistance.

**Note: Tests above were performed with the material and curing conditions @ 71°F – 75°F and 45-55% relative humidity.**

## **Part 3 – Execution**

### **3.01 Surface Preparation**

- A. Concrete surfaces must be prepared by suitable mechanical means, by abrasive blast cleaning or high pressure water at sufficient volume and pressure to remove all surface contaminants such as oil, grease, curing membranes, efflorescence, algae, moss, dirt, etc. All loose materials and any existing coatings must be removed to provide a clean, sound, dry, and absorbent surface prior to application of the Sika FerroGard 903.

### **3.02 Mixing and Application**

- A. Apply Sika FerroGard 903 at a total minimum consumption rate 200 sf/gallon/coat by brush, roller, or low pressure spray in two coats (dependent on absorbency) for a total consumption of 100 sf./gallon.

Note: When Sika FerroGard 903 is to be applied before Sika mortars thoroughly wash down surfaces using clean water. Any white powdery residue must be removed by water jetting using adequate volume and pressure

Note: Best results are usually obtained by low pressure spray application.

Note: Between applying the subsequent coats of Sika FerroGard 903 allow the previous coats to be absorbed into the concrete and dry (approximately 2-6 hours minimum dependent on temperature and humidity).

Note: The treated area should be protected from rain or frost for a period of at least 24 hours after application of Sika FerroGard 903.

- B. Adhere to all procedures, limitations and cautions for this product in the manufacturer's current printed technical data sheet and literature.

### **3.05 Cleaning**

- A. The material can be cleaned from tools with water.
- B. Leave finished work and work area in a neat, clean condition without evidence of spillovers onto adjacent areas.

## SC-203 Sika FerroGard® 903

Penetrating, corrosion-inhibiting  
Impregnation coating

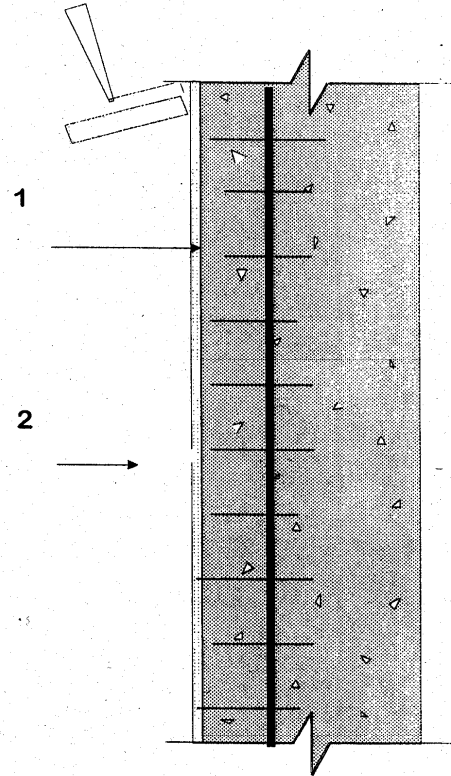
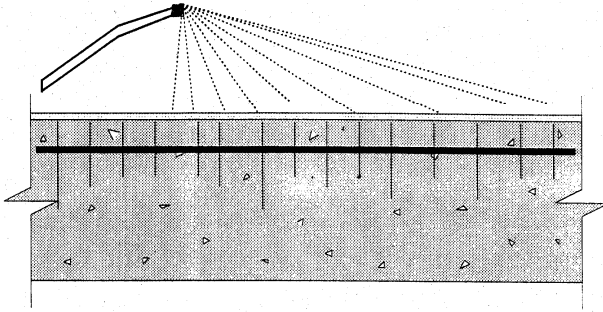

1. Substrate must be clean, sound and free of standing water.

NOTE: While residual moisture does not affect the treatment, the drier the substrate the better the penetration and protection.

2. Apply Sika FerroGard 903 by roller, brush or spray.

NOTE: When spraying, use a conventional airless spray system or hand-pressure equipment.

3. A minimum of two coats is always recommended. Waiting time between coats is 1 hour minimum.

The preceding specifications are provided by Sika Corporation as a guide for informational purposes only and are not intended to replace sound engineering practice and judgment and should not be relied upon for that purpose. **SIKA CORPORATION MAKES NO WARRANTY OF ANY KIND, EITHER EXPRESS OR IMPLIED, AS TO THE ACCURACY, COMPLETENESS OR THE CONTENTS OF THESE GUIDE SPECIFICATIONS.** Sika Corporation assumes no liability with respect to the provision or use of these guide specifications, nor shall any legal relationship be created by, or arise from, the provision of such specifications **SIKA SHALL NOT BE RESPONSIBLE UNDER ANY LEGAL THEORY TO ANY THIRD PARTY FOR ANY DIRECT OR CONSEQUENTIAL DAMAGES OF ANY KIND ARISING FROM THE USE OF THESE GUIDE SPECIFICATIONS.** The specifier, architect, engineer or design professional or contractor for a particular project bears the sole responsibility for the preparation and approval of the specifications and determining their suitability for a particular project or application.

Prior to each use of any Sika product, the user must always read and follow the warnings and instructions on the product's most current Technical Data Sheet, product label and Material Safety Data Sheet which are available at [www.sikaconstruction.com](http://www.sikaconstruction.com) or by calling (201) 933-7452. Nothing contained in any Sika materials relieves the user of the obligation to read and follow the warnings and instructions for each Sika product as set forth in the current Technical Data Sheet, product label and Material Safety Data Sheet prior to product use.



**SCHEDULE G – CONSTRUCTION PLAN SET**

**FOLLOWS THIS PAGE**

# MEMORIAL PARK WAR MEMORIAL

300 S UNION BLVD,  
COLORADO SPRINGS, CO 80910

MARTIN/MARTIN PROJECT NO. 24.0871.S01  
BID SET: 08/26/2024



**AERIAL PHOTO**



PROJECT LOCATION

**VICINITY MAP**

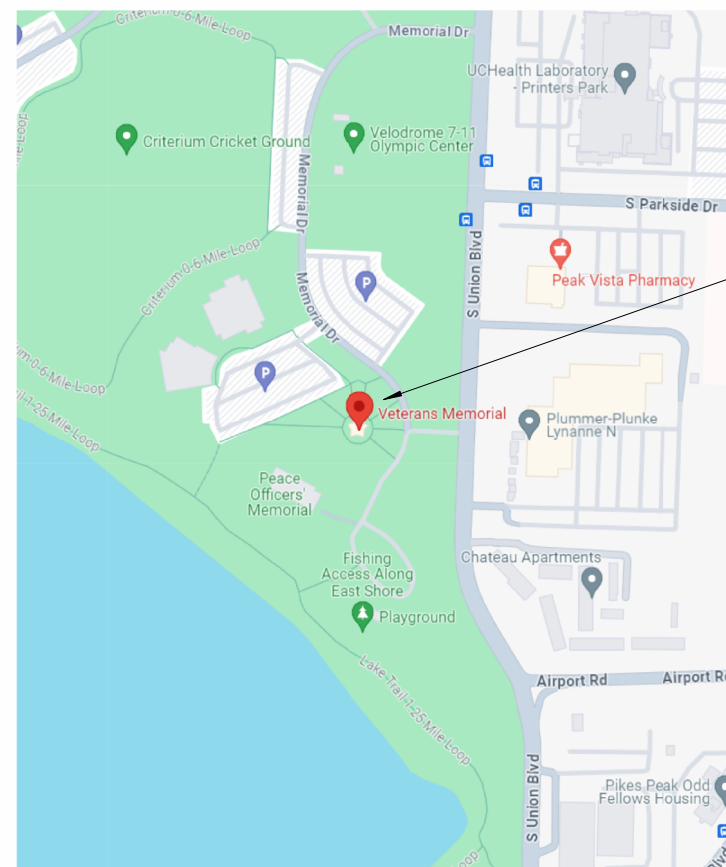

PROJECT LOCATION

**CONSULTANT**



12499 WEST COLFAX AVENUE, LAKEWOOD, COLORADO 80215  
MAIN 303.431.6100 MARTINMARTIN.COM

**DRAWING INDEX**

Sheet List	
Sheet Number	Sheet Name
S0.1	GENERAL NOTES
S1.0	SITE PLAN
S2.0	DETAILS

**OWNER'S REPRESENTATIVE**

CITY OF COLORADO SPRINGS

CONTACT: CONNIE SCHMEISSER  
719.385.6533  
Constance.Schmeisser@coloradosprings.gov



DESIGNERS DAN CRISSEN/LEAFER  
 LEAD REVIT TECHNIQUE MATA  
 DATE PRINTED 08/26/24 16:22:55  
 FILE PATH: AutoCAD/Docs/ACC-MM Structural Projects/2024/24.0871.S.01.3001 S UNION BLVD - WAR MEMORIAL\_S24.rvt

MM JOB # 24.0871.S01  
 PRINCIPAL INCHOLE LANE  
 EOR DAVE WITTMAN  
 PROJECT MANAGER DAVE WITTMAN

R24-115M2



**SITE PLAN**  
 NO SCALE

1  
 S1.0



**1 WAR MEMORIAL AERIAL VIEW**  
 NO SCALE

**WORK LIST**

WORK ITEM	DESCRIPTION	ESTIMATED QUANTITY	REFERENCE DETAIL
1	REMOVE EXISTING WHITE COATING PRIOR TO INSTALLING NEW COATING. CONTRACTOR TO CREATE A MOCKUP OF PROPOSED PAINT REMOVAL METHODS FOR APPROVAL BY OWNER PRIOR TO BEGINNING WORK. MOCKUPS TO BE PERFORMED ON THE INNER PERIMETER OF THE MONUMENT.	1,000 SF	10/S2.0
2	PROTECT EXISTING ORNAMENTAL METAL, STONE ELEMENTS, AND SPEAKERS DURING ADJACENT CONCRETE WORK.	10 LOCS	11/S2.0
3	REMOVE RUST AND DETERIORATED GROUT FROM THE PRECAST LIFTING POINTS AND REPAIR SPALL LOCATIONS. REPAIRS FINISH SHALL MATCH EXISTING FINISH.	120 LOCS	4/S2.0 6/S2.0 11/S2.0
4	REMOVE CORROSION FROM OF ALL STEEL ELEMENTS, CONNECTIONS, AND EMBED PLATES. PAINT WITH A ZINC RICH PRIMER.	10 SF	5/S2.0
5	REPLACE CONCRETE AT CORE SAMPLES REMOVED FOR PETROGRAPHY TESTING. EXTERIOR FACE OF CONCRETE REPAIR TO MATCH EXISTING CONCRETE FINISHES.	12 LOCS	5/S2.0
6	IF CONCRETE DELAMINATIONS ARE DISCOVERED DURING REPAIRS, REMOVE AND REPLACE DELAMINATED CONCRETE. EXTERIOR FACE OF CONCRETE REPAIR TO MATCH EXISTING CONCRETE FINISHES. ESTIMATED QUANTITY IS FOR BIDDING PURPOSES ONLY.	100 SF	4/S2.0
7	INSTALL PENETRATING CORROSION INHIBITOR AND SILICONE COATING ON ALL CONCRETE SURFACES. FOR BIDDING PURPOSES, ASSUME THE PRODUCTS TO BE USED ARE SIKA FERROGARD 903 AND GE OPTIC 3101 TRANSLUCENT SILICONE COATING. COORDINATE WITH OWNER TO LOCATE WHERE A PAINTED FINISH IS REQUIRED. THE PAINT LAYER IS TO BE APPLIED BETWEEN THE CORROSION INHIBITOR AND THE SILICONE COATING. CONTRACTOR TO CREATE A MOCKUP OF PROPOSED REPAIRS FOR APPROVAL BY OWNER PRIOR TO BEGINNING WORK. MOCKUP TO BE PERFORMED ON THE INNER PERIMETER OF THE MONUMENT.	2,000 SF	10/S2.0
8	INSTALL CAP FLASHING ON TOP OF EACH VERTICAL CONCRETE ELEMENT AFTER COATING HAS BEEN APPLIED.	5 LOCS	5/S2.0 9/S2.0

**WORK LIST NOTES:**

- THE VALUES IN THE "ESTIMATED QUANTITY" COLUMN OF THE WORK LISTS MAY BE GREATER THAN OR LESS THAN THE AMOUNTS SHOWN ON PLAN. USE THE QUANTITIES LISTED IN THE WORK LIST FOR BID PURPOSES AND PROVIDE UNIT COSTS. CONTRACTOR SHALL FIELD VERIFY QUANTITIES AND LOCATIONS PRIOR TO WORK.
- BID PRICING SHALL REFLECT THE PRODUCTS SPECIFIED IN THIS DOCUMENT. SUBSTITUTIONS AND ASSOCIATED PRICING MAY BE SUBMITTED IN ADDITION TO THE UNIT COST PRICES FOR THE SPECIFIED MATERIALS. THE ENGINEER SHALL REVIEW AND EVALUATE IF THE ALTERNATE PRODUCT IS CONSIDERED "EQUAL" AND IF IT WILL BE ALLOWED AS A SUBSTITUTION.



**MEMORIAL PARK WAR MEMORIAL**

300 S UNION BLVD,  
 COLORADO SPRINGS, CO 80910

**REVISIONS**

NO.	ISSUE	DATE
-----	-------	------

95% REVIEW SET		07/29/2024
----------------	--	------------

PROJECT NO: 24.0871.S01

DATE: 08/26/2024

© MARTINMARTIN 2024

SHEET TITLE:  
**SITE PLAN**

SHEET NUMBER:  
**S1.0**



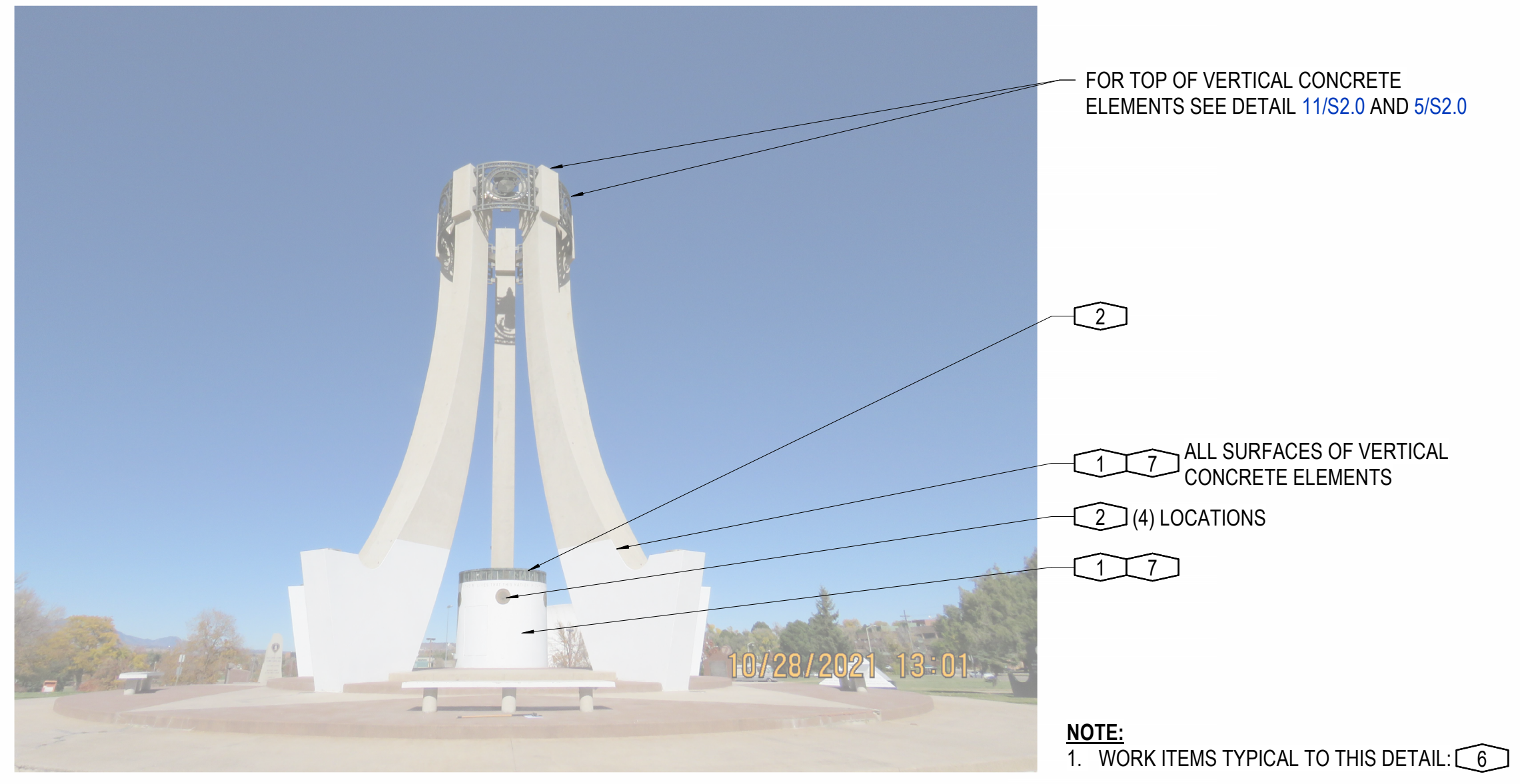

**10** NO SCALE ELEVATION OF MONUMENT

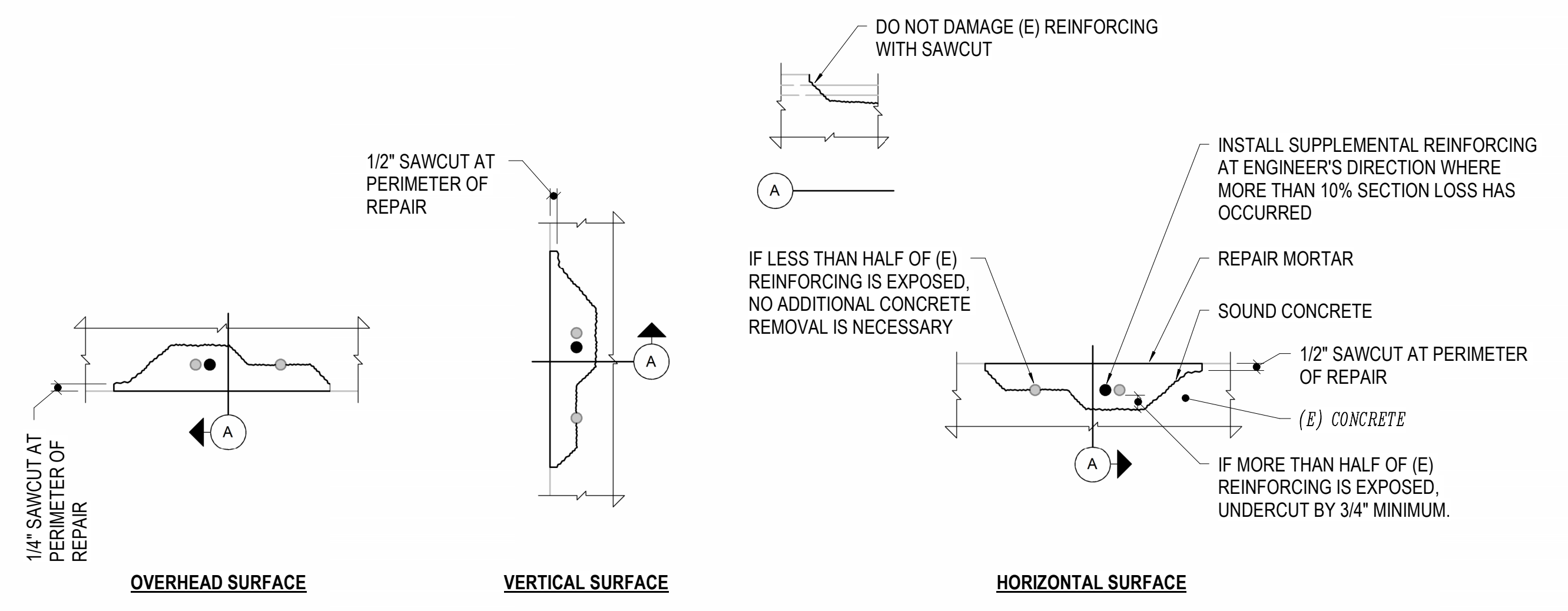

**NOTES:**  
 1. SEE CONCRETE REPAIR NOTES FOR REQUIREMENTS.  
 2. PREPARE SURFACES, INSTALL, AND CURE REPAIR MATERIALS IN STRICT ACCORDANCE WITH PRODUCT MANUFACTURER'S LITERATURE.

**4** NO SCALE PARTIAL DEPTH CONCRETE REPAIR



**11** NO SCALE TOP SIDE VIEW OF MONUMENT

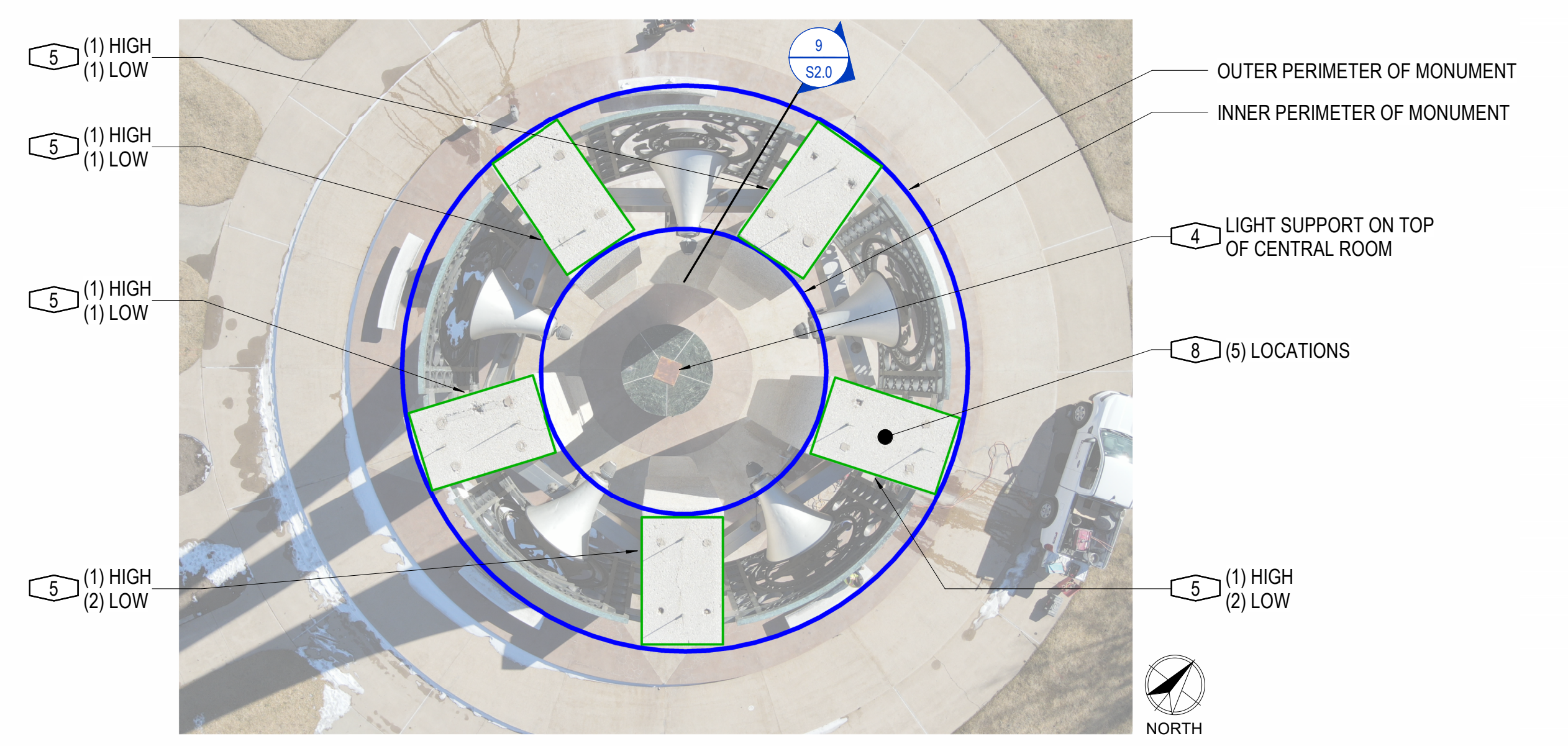

**5** NO SCALE AERIAL VIEW OF MONUMENT

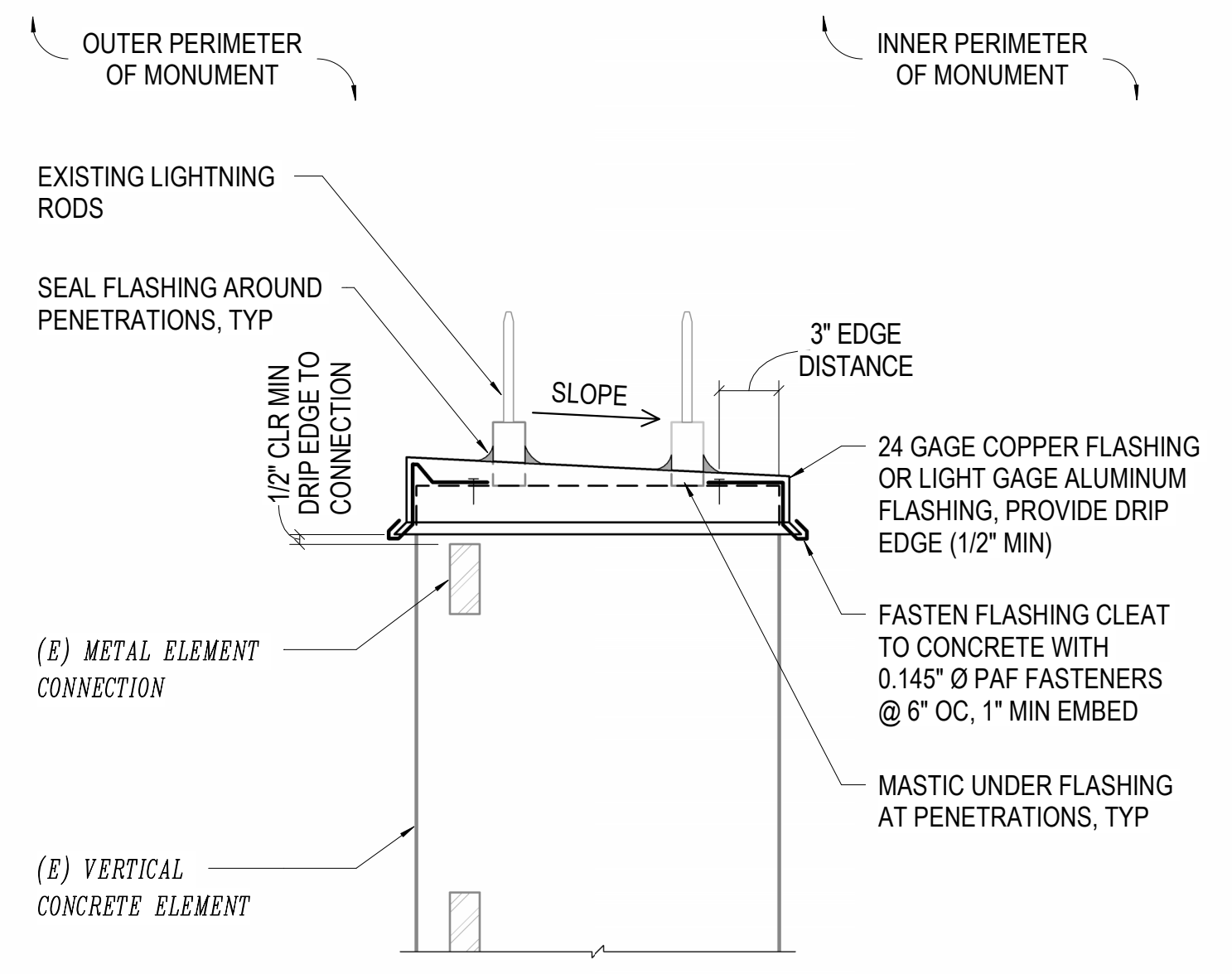

**9** NO SCALE CAP FLASHING

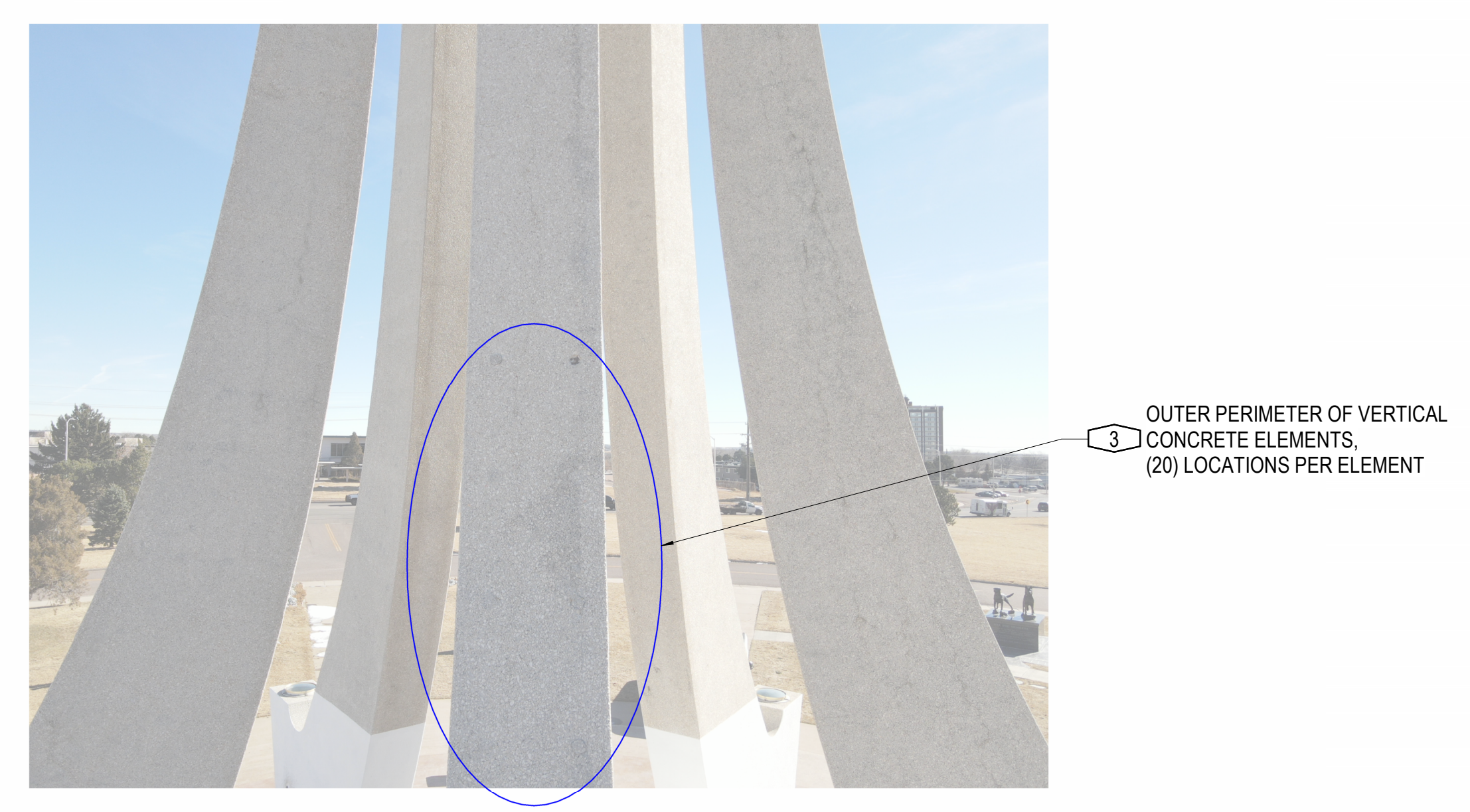

**6** NO SCALE FACE OF VERTICAL CONCRETE ELEMENT

**MEMORIAL PARK WAR MEMORIAL**  
 300 S UNION BLVD,  
 COLORADO SPRINGS, CO 80910

**REVISIONS**

NO.	ISSUE	DATE
95% REVIEW SET		07/29/2024

PROJECT NO: 24.0871.S01  
 DATE: 08/26/2024  
 © MARTINMARTIN 2024

SHEET TITLE:  
**DETAILS**

SHEET NUMBER:  
**S2.0**

DESIGNER: DAN GRIENAUER  
 LEAD REVIT TECHNIQUE: MATA  
 DATE PRINTED: 08/26/24 16:23:06  
 FILE PATH: AutoCAD/Docs/ACC-M/M Structural Projects/2024/24.0871.S01-300 S UNION BLVD - WAR MEMORIAL\_S24.rvt  
 PROJECT MANAGER: DAVE WITTMAN  
 R24-115M2