



REQUEST FOR PROPOSAL

Construction

R24-129SL

Date issued: October 9, 2024

SAND CREEK POND 2 IMPROVEMENT PROJECT

THE CITY OF COLORADO SPRINGS



The City of Colorado Springs requests Firm Unit Price (FUP) proposals, as detailed in this Request for Proposal (RFP), for R24-129SL Sand Creek Pond 2 Improvement Project.

This RFP is posted to Rocky Mountain E-Purchasing BidNet Direct and the City of Colorado Springs' Procurement Services Website. It is available for all vendors free of charge, following free registration, at the Rocky Mountain E-Purchasing BidNet Direct website.

SUBMITTALS FOR THIS PROJECT WILL ONLY BE ACCEPTED ON THE ROCKY MOUNTAIN E-PURCHASING BIDNET DIRECT PLATFORM.

Please login to the following website to register (Free Registration) to submit a bid for this project. All required documents will be uploaded to the website.

<https://www.bidnetdirect.com/>

BIDNET Support

800-835-4603

Estimated Project Magnitude: \$6,500,000 - \$7,500,000



SECTION INDEX

SECTION I PROPOSAL INFORMATION

SECTION II PROPOSAL CONTENT

SECTION III EVALUATION FACTORS

SECTION IV SPECIAL CONTRACT TERMS AND CONDITIONS/SPECIAL SOLICITATION PROVISIONS

SECTION V EXHIBITS

SECTION VI SCHEDULES



SECTION I – PROPOSAL INFORMATION

1.0 PROPOSAL INFORMATION

Section I provides general information to potential Offerors, such as proposal submission instructions and other similar administrative elements. This RFP is available on BidNet Direct under the Rocky Mountain E-Purchasing Group (www.BidNetDirect.com). All addenda or amendments shall be issued through BidNet Direct and may not be available through any other source.

1.1 RFP SCHEDULE OF EVENTS

The upcoming schedule of events is as follows:

<u>Event</u>	<u>Date</u>
Issue Request for Proposal	October 9, 2024
Pre-Proposal Conference	October 16, 2024 at 2:00PM MST

We will hold a pre-proposal conference via Microsoft Teams. This meeting is not mandatory. However, all Offerors are encouraged to attend. Please use the link below to attend the meeting:

Microsoft Teams [Need help?](#)

[Join the meeting now](#)

Meeting ID: 266 953 735 461

Passcode: o9Umhu

Dial in by phone

[+1 720-617-3426,,542124915#](tel:+17206173426,542124915) United States, Denver

[Find a local number](#)

Phone conference ID: 542 124 915#

Cut Off Date for Questions October 25, 2024 by 2:00PM MST

All questions shall be submitted electronically via the BidNet Direct Procurement Platform (www.bidnetdirect.com) to the following Contract Specialist. All questions must be received no later than **October 25, 2024 by 2:00PM MST.**

Requests for Information, support and questions shall be directed to:

Sarah M. Lagunas

Sarah.Lagunas@coloradosprings.gov

DO NOT CONTACT ANY OTHER INDIVIDUAL AT THE CITY OF COLORADO SPRINGS REGARDING THIS SOLICITATION.
--



The only acceptable method of submitting questions is electronically via BidNet Direct. Faxes or physical mail delivery are not acceptable.

Proposal Due Date	November 11, 2024 by 2:00PM MST
Interviews (if applicable)	TBD
Award of Contract	Tentatively November 2024
Notice to Proceed	Tentatively November 2024

1.2 SUBMISSION OF PROPOSAL

Proposals are to be submitted electronically on BidNet Direct (www.bidnetdirect.com). Please review the submission requirements **well in advance** of submission date and time, and allow for ample time to upload each required document. It is recommended that Offerors begin the submission process at least one (1) day in advance of the proposal deadline.

Offerors are solely responsible to ensure all required proposal documents are uploaded and submitted correctly, and that a **confirmation number** is obtained upon successful submission. Customer support for BidNet Direct may be reached at (800) 835-4603.

*******NO LATE OFFERS WILL BE ACCEPTED*******

Date/Time: Proposals shall be received on or before November 11, 2024 by 2:00PM MST.

Identification of Proposal:

Proposals must be submitted to the BidNet Direct Procurement Platform (www.bidnetdirect.com). The solicitation number and Offeror name must be clearly marked within the proposal.

Proposal No.: R24-129SL
Due Date and Time: November 11, 2024 by 2:00PM MST

Any offer that is submitted without being properly marked may be opened for identification prior to the deadline for receipt of proposals and then resealed.

1.3 NUMBER OF COPIES

Offerors shall submit **one (1)** softcopy to the BidNet Direct platform. Upon submission, all proposal documents shall become and remain the property of the City of Colorado Springs.

1.4 SPECIAL TERMS

Please note the following definitions of terms as used herein:

The term "City" means the City of Colorado Springs.



The term “Contractor” or “Consultant” means the Offeror whose offer is accepted and is awarded the contract to provide the products or services specified in the RFP.

The term “Offer” means the proposal.

The term “Offeror” means the person, firm, or corporation that submits a formal proposal or offer and that may or may not be successful in being awarded the contract.

The term “Project” refers to Sand Creek Pond 2 Improvement Project.

The term “Request for Proposal” or “RFP” means this solicitation of a formal, negotiable proposal/offer. Any offer that is accepted will be the offer that is deemed by the City of Colorado Springs to be most advantageous in terms of the criteria designated in the RFP.

1.5 RFP OBJECTIVE

The objective of this RFP is to provide sufficient information to enable qualified Offerors to submit written proposals to the City of Colorado Springs. The RFP is not a contractual offer or commitment to purchase products or services. The Offeror may present options and variables to the scope while still meeting the minimum requirements of this solicitation. Innovative proposals/solutions are encouraged and considered in the selection and/or award.

All information included in proposals must be legible. Any and all corrections and or erasures must be initialed by Offeror. Each proposal shall be accompanied by a cover letter signed by an authorized representative of the Offeror. The contents of the proposal submitted by the successful Offeror may become part of any contract awarded as a result of this solicitation.

1.6 CONFIDENTIAL OR PROPRIETARY INFORMATION

If an Offeror believes that parts of an offer are confidential, then the Offeror must so specify. The Offeror must include in bold letters the term “CONFIDENTIAL” on that part of the offer which the Offeror believes to be confidential. The Offeror must submit in writing specific detailed reasons, including any relevant legal authority, stating why the Offeror believes the material to be confidential. Vague and general claims as to confidentiality will not be accepted. The City of Colorado Springs will be the sole judge as to whether a claim is acceptable. Decisions regarding the confidentiality of information will be made when requests are made to make the information public. All offers and parts of offers, which are not marked as confidential, will automatically be considered public information after the contract is awarded. The successful offer may be considered public information even though parts are marked confidential.

1.7 AMENDMENTS

Amendments to this RFP may be issued at any time prior to the time set for receipt of proposals. Offerors are required to acknowledge receipt of any amendments issued to this RFP by returning a signed copy of each amendment issued. Signed copies of each amendment must be received on or before the time set for receipt of offers.



The City of Colorado Springs will post all amendments on BidNet Direct under the Rocky Mountain E-Purchasing Group (www.BidNetDirect.com). It is the Offeror's responsibility to check the website for posted amendments or contact the Contracts Specialist listed in RFP §1.1 to confirm the number of amendments which have been issued.

1.8 WITHDRAWAL OR MODIFICATION OF OFFERS

Any Offeror may modify or withdraw an offer in writing at any time prior to the deadline for submission of an offer.

1.9 ACCEPTANCE

Any offer received and not withdrawn shall be considered an offer, which may be accepted by the City of Colorado Springs based on initial submission without discussions or negotiations.

By submitting an offer in response to this solicitation, the Offeror agrees that any offer it submits may be accepted by the City of Colorado Springs at any time within 90 calendar days from the date of submission deadline.

The City of Colorado Springs reserves the right (a) to reject any or all offers,(b) to waive informalities and minor irregularities in offers received, and/or (c) to accept any portion of an offer if deemed in the best interest of the City of Colorado Springs. Failure of the Offeror to provide in its offer any information requested in the RFP may result in rejection of the offer for non-responsiveness.

1.10 PROPOSAL PREPARATION COST

The cost of proposal preparation is not a reimbursable cost. Proposal preparation shall be at the Offeror's sole expense and is the Offeror's total and sole responsibility.

1.11 AWARD

The City of Colorado Springs intends to make an award using the evaluation criteria listed in this RFP to determine the best value, considering all factors and criteria in the proposals submitted. Best value means the expected outcome of an acquisition that, in the City's estimation, provides the greatest overall benefit in response to the requirements detailed in the RFP. The City of Colorado Springs reserves the right to reject any or all offers and to not make an award.

1.12 PERFORMANCE PERIOD

The performance period for the project detailed in this RFP will be established as 300 calendar days from the issuance of a notice to proceed.

1.13 DEBRIEFING

Offerors not selected may request a debriefing on the selection process as well as discussion of the strengths and weaknesses of their proposal upon receipt of notification that their offer was not selected.



A debriefing may be scheduled by contacting the Contracts Specialist listed above. The Contracts Specialist must receive a written request for debriefing no later than ten (10) calendar days after issuance of a notification that the Offeror's offer was not selected.

1.14 SUBSTANTIVE PROPOSALS

By responding to this RFP, the Offeror certifies (a) that Offeror's proposal is genuine and is not made in the interest of, or on behalf of, an undisclosed person, firm, or corporation; (b) that Offeror has not directly or indirectly induced or solicited any other offerors to put in a false or sham proposal; (c) that Offeror has not solicited or induced any other person, firm, or corporation to refrain or abstain from proposing an offer or proposal; (d) that Offeror has not sought by collusion to obtain for themselves any advantage over any other offerors or over the City of Colorado Springs; and (e) that Offeror has not violated or caused any person to violate, and shall not violate or cause any person to violate, the City's Code of Ethics contained in Article 3, of Chapter 1 of the City Code and in the City's Procurement Rules and Regulations.

1.15 OFFEROR'S QUALIFICATIONS

Each Offeror must complete Exhibit 4 – Qualifications Statement.

No contract will be awarded to any Offeror who is in arrears to the City, upon any debt or contract, or who is in default, in any capacity, upon any obligation to the City or is deemed to be irresponsible or unreliable by the City based on past performance.

1.16 NON-COLORADO ENTITIES

If Offeror is a foreign entity, Offeror shall comply with C.R.S. section 7-90-801, "Authority to transact business or conduct activities required," and section 7-90-802, "Consequences of transacting business or conducting activities without authority."

Before or at the time that the contract is awarded to an entity organized or operating outside the State of Colorado, such entity shall obtain authorization to do business in the State of Colorado, designate a place of business herein, and appoint an agent for service of process.

Such entity must furnish the City of Colorado Springs with a certificate from the Secretary of the State of Colorado to the effect that a certificate of authority to do business in the State of Colorado has been issued by that office and is still valid. The entity shall also provide the City with a certified copy of the designation of place of business and appointment of agent for service of process from the Colorado Secretary of State, or a letter from the Colorado Secretary of State that such designation of place of business and agent for service of process has been made.

1.17 PROCUREMENT RULES AND REGULATIONS

All projects advertised by the City of Colorado Springs are solicited in accordance with the City's Procurement Rules and Regulations. The City's Procurement Rules and Regulations can be reviewed and/or downloaded from the City website www.coloradosprings.gov. The Contracts Specialist may also provide a softcopy of the Rules and Regulations upon request. Any discrepancies regarding conflicting statements, decisions, irregularities, clauses, or specifications will be rectified utilizing the City's Procurement Rules and Regulations, when applicable. It is the



Offeror's responsibility to advise the Contracts Specialist listed in this RFP of any perceived discrepancies prior to the date and time the offer is due.

1.18 FAIR TREATMENT OF OFFERORS

The City Procurement Services Division shall be responsible for ensuring the procurement of products, commodities, and services are in a manner that affords all responsible businesses a fair and equal opportunity to compete. If an Offeror believes that a procurement is not conducted in a fair and equitable manner, the Offeror is encouraged to inform the City Procurement Services Manager as soon as possible.

1.19 ORDER OF PRECEDENCE

Any inconsistency in this solicitation shall be resolved by giving precedence in the following order:

- A. Sections I-IV of this Solicitation
- B. Special Construction Terms and Conditions
- C. General Construction Terms and Conditions
- D. Exhibits
- E. Plans
- F. Detailed Plans
- G. Standard Drawings
 - a. Calculated dimensions will govern over scaled dimensions.
- H. Special Specifications
- I. Standard Specifications

1.20 SALES TAX

The successful Offeror, if awarded a contract, shall apply to the Colorado Department of Revenue for a tax-exempt certificate for this project. The certificate does not apply to City of Colorado Springs Sales and Use Tax which shall be applicable and should be included in all proposals. The tax exempt project number and the exemption certificate only apply to County, PPRTA (Pikes Peak Rural Transportation Authority), and State taxes when purchasing construction and building materials **to be incorporated into this project**.

Furthermore, the exemption **does not** include or apply to the purchase or rental of equipment, supplies or materials that **do not become a part of the completed project or structure**. In these instances, the purchase or rental is subject to full taxation at the current taxation rate.

The Offeror and all subcontractors shall include in their Offer City of Colorado Springs Sales and Use Tax on the work covered by the offer, and all other applicable taxes.

Forms and instructions can be downloaded at <https://coloradosprings.gov/sales-tax>. Questions can be directed to the City Sales Tax Division at (719) 385-5903 or Construction_SalesTax@coloradosprings.gov.

Our Registration Numbers are as follows:
City of Colorado Springs
Federal I.D.: 84-6000573



Federal Excise: A-138557
State Sales Tax: 98-03479

1.21 BOND REQUIREMENTS

The Offeror is advised that the successful Offeror shall be required to furnish to the City of Colorado Springs, upon award, one copy of each: Performance Bond, Labor and Materials Payment Bond, and a Maintenance Bond in the amount of 100% of the total contract within ten (10) calendar days after notification of award of a contract. The cost of all bonds shall be included in Offeror's offer.

Bonds shall:

- A. Be for the full amount of the contract price.
- B. Guarantee the Contractor's faithful performance of the work under the contract, and the prompt and full payment for all labor and materials involved therein.
- C. Guarantee protection to the City of Colorado Springs against liens of any kind.
- D. Be, when a surety bond is furnished, from a surety company operating lawfully in the State of Colorado and be accompanied with an acceptable "Power-of-Attorney" form attached to each bond copy.
- E. Be issued from a surety company that is acceptable to the City of Colorado Springs.
- F. Be submitted using the forms in the Exhibit section of this solicitation.

1.22 INTERPRETATION OF QUANTITIES IN PROPOSAL FORM

Except as otherwise provided in this RFP, the quantities appearing in the proposal form are estimates prepared for the comparison of proposals.

After award, payment to the Contractor will be made in accordance with the following procedures:

- A. Measurement required. When the Contract requires measurement of work performed or material furnished, payment will be made for actual quantities measured and accepted.
- B. Measurement Not Required. When the Contract does not require quantities of work performed or materials furnished to be measured, payment will be made for the quantities appearing in the Contract.

The estimated quantities of work to be performed and materials to be furnished may be increased, decreased or omitted.

1.23 INTERPRETATION OF PLANS AND SPECIFICATIONS

Any change to proposal forms, plans, or specifications prior to the opening of proposals will be issued by the City in the form of an Amendment. Certain individuals may be named in the RFP that have authority to provide information, clarification or interpretation to Offerors prior to opening of proposals. Information obtained from persons other than those named individuals is invalid and shall not be used for proposal purposes.



1.24 EXAMINATION OF PLANS, SPECIFICATIONS, SPECIAL PROVISIONS, AND SITE OF WORK.

The Offeror is expected to examine the site of the proposed work, the proposal, plans, specifications, supplemental specifications, special provisions, and Contract forms, before submitting a proposal. The submission of a proposal will be considered conclusive evidence that the Offeror has made this examination and is aware of the conditions to be encountered in performing the work according to the Contract.

Boring logs and other records of subsurface investigations, if they exist, are available for inspection by Offerors. These logs and records are made available so that all Offerors have access to identical subsurface information that is available to the City, and is not intended as a substitute for personal investigation, interpretation, and judgment of the Offerors.

The City does not warrant the adequacy of boring logs and other records of subsurface investigations, and such information is not considered to be a part of the Contract. When a log of test borings is included in the subsurface investigation record, the data shown in the individual log of each test boring apply only to that particular boring and are not intended to be conclusive as to the character of any material between or around test borings. If Offerors use this information in preparing a proposal, it is used at their own risk, and Offerors are responsible for all conclusions, deductions, and inferences drawn from such information.

Offerors may conduct subsurface investigations at the project site at Offeror's expense; the City will afford them this opportunity prior to public opening of proposals.

If an Offeror discovers an apparent error or omission in the proposal form, estimated quantities, plan, or specifications, the Offeror shall immediately notify the Contracting Specialist to enable the City to make any necessary revisions. The City may consider it to be detrimental to the City for an Offeror to submit an obviously unbalanced unit proposal price.

1.25 COMBINATION OR CONDITIONAL PROPOSALS

If an RFP is issued for projects in combination and separately, the Offeror may submit proposals either on the combination or on separate units of the combination. The City reserves the right to make awards on combination or separate proposals to the advantage of the City. Combination proposals will be considered, only when specified.

1.26 ANTI-COLLUSION AFFIDAVIT

The Offeror by signing their proposal submitted to the City is certifying that the Offeror has not participated in any collusion or taken any action in restraint of free competitive bidding. This statement may also be in the form of an affidavit provided by the City and signed by the Offeror. The original of the signed anti-collusion affidavit, if separately required and provided with the RFP, shall be submitted with the proposal. The proposal will be rejected if it does not contain the completed anti-collusion affidavit.



1.27 MATERIAL GUARANTY

The successful Offeror may be required to furnish a complete statement of the origin, composition, and manufacture of materials used in the construction of the work together with samples, which will be tested for conformance with Contract requirements.



SECTION II – PROPOSAL CONTENT

2.0 PROPOSAL CONTENT

- A. Section II provides instructions regarding the format and content required for proposals submitted in response to this solicitation.

2.1 PROPOSAL FORMAT

Offeror's written proposal should include concise, but complete, information, emphasizing why the Offeror is best or best qualified to provide the required services. The Offeror's written proposal should include the information in the format outlined below and must be limited to no more than twenty-five (25) pages. **A page shall be defined as 8-1/2" x 11"; single sided, with one inch margins, and a minimum font of Times New Roman 10.** The only exception to the 8-1/2" x 11" paper size is the proposed project schedule. It may be submitted on 11" x 17" paper. Each 11" x 17" page for the schedule shall be counted in the overall page limitations above. Each section of the proposal should be labeled to clearly follow the requirements sections identified in this section of the RFP. The following listed Exhibits must be filled out and returned with the proposal and are not counted against the page limit:

Exhibit 1 Qualification Documents
Schedule A Bid Tab
Addenda, if applicable

2.2 COVER LETTER

The cover letter shall be no more than three pages. The cover letter shall contain at least the following information.

- A. RFP Number and Project Name.
- B. Statement that the Offeror is qualified to perform the work.
- C. Certification Statement that the information and data submitted are true and complete to the best knowledge of the individual signing the letter.
- D. Name, telephone number, email address, and physical address of the individual to contact regarding the proposal.
- E. The signature of an authorized principal, partner, or officer of the Offeror.

2.3 PROPOSAL CERTIFICATION

The Offeror must fill out and submit Exhibit 1 with its Proposal.

2.4 ORGANIZATIONAL BACKGROUND AND OVERVIEW

The Offeror must provide a brief history and overview of its company and its organizational structure, with special emphasis on how this project will fit within that structure. Also include principal place of business location(s), office locations, size of firm, and financial stability (annual public reports or private financial statements shall be included in an appendix or under separate cover; private financial information will be kept confidential by the City).



2.5 PROPOSAL NARRATIVE/TECHNICAL AND MANAGEMENT APPROACH

In the proposal narrative/technical and management approach section, the Offeror should explain what the Offeror will do and how it will perform if awarded a contract.

2.5.1 TECHNICAL AREA

The Offeror must explain its overall solution, considering the scope of work or statement of work provided. The content must include, but not necessarily be limited to, the following information.

A. Understanding of and Compliance with Technical Requirements

In the Technical Area, the Offeror should address each work area in sufficient detail to demonstrate a clear and full understanding of the work necessary to complete the project. The proposal should not merely parrot the requirements of the RFP. Further, the Offeror should provide evidence of sufficient planning to ensure the work is completed on schedule and within budget. It is highly recommended that the Offeror provide sufficient content and detail to answer completely the following questions:

1. Does the proposal demonstrate a firm understanding of the requirements and goals of the Statement of Work, as well as industry standards and reasonable expectations for a company in the industry?
2. Does the proposal fully and completely address each requirement and goal of the Statement of Work?
3. Does the proposal provide solutions to indicate that requirements and goals will be met on schedule?
4. Does the technical solution seem realistic?
5. Does it generally appear that the Offeror knows and thoroughly understands the business and the RFP requirements?

B. Project Approach

In the Technical Area, the Offeror should clearly present proposed solutions and indicate that it has performed adequate planning to accomplish project tasks as defined in the Statement of Work. Innovations, efficiencies, and detailed specifics are all encouraged.

The Offeror must at least address the following areas:

1. Construction phasing and traffic control for the project. Explain the phases, traffic control for each phase, and the logic in the construction phasing.
2. Erosion and sediment control during all phases of construction as well as post construction efforts through permit closure.
3. Coordination with utilities. Discuss Offeror's understanding of the key utility relocations required for this project and how Offeror will coordinate and phase construction to both facilitate and accommodate those relocations and the constraints that they impose.
4. Schedule Management. Discuss Offeror's approach to schedule management including updating and reporting progress of the work.



5. Quality Control. Discuss Offeror's quality control plan, processes and approach to ensure that the City receives a quality product.
6. Safety. Discuss Offeror's approach and commitment to safety for both construction workers and the public traveling through the construction site.
7. Potential issues that Offeror foresees with this project and how Offeror would make adjustments if encountered. Describe factors limiting construction phasing flexibility and potential remedies.

It is highly recommended that the Offeror provide sufficient content and detail to answer completely the following questions.

1. Does the proposal include a complete plan to accomplish each requirement, including subcontracting (if applicable)?
2. Does the proposal demonstrate that appropriate and qualified personnel and equipment will be provided to carry out the requirement?
3. Is the proper level of effort directed toward each requirement? Does the level of effort look unrealistically low or unreasonably high?

2.5.2 MANAGEMENT AREA

The Offeror must explain its method of managing the work to be performed. The content must include, but no necessarily be limited to, the following information.

A. Program Management Controls

In the Management Area, the Offeror should provide:

1. A plan of operation, to include management of personnel, workload, schedule, and budget
2. An organization chart which demonstrates clear and effective lines of authority, responsibility, and communication for management, supervisory, and technical personnel. The plan should address which job classification or personnel will be assigned to each task and how that determination is made. Basic human resource management concepts should be addressed, including hiring, firing, discipline, incentive plans, etc.
3. If the Offeror plans to subcontract more than 10% of the work, include information on how the Offeror plans to manage its subcontractors.
4. A detailed construction schedule for the project showing the key construction activities and how they will meet or improve the City's timeframe and maximize construction efficiency to provide the best value to the City and minimize impacts to the public. The schedule shall be based on the Offeror's understanding and approach to the work as addressed above. Schedules should address controls to ensure the project will remain on schedule and on budget.

It is highly recommended that the Offeror provide sufficient content and detail to answer completely the following questions.

1. Does the proposal address the issues above in sufficient detail to demonstrate a sophisticated and mature management control system?



2. Are program management controls consistent with the technical portion of the proposal, especially regarding schedule and level of effort?
3. Do the plan and controls indicate that the Offeror will obtain, keep, and efficiently utilize high-quality personnel?
4. Does the proposal explain how the Offeror will address corrective actions in case of delays (e.g. expediting materials, additional resources, etc.)?
5. Does the proposal explain how the Offeror will remain within schedule and budget?

B. Past Performance/Relevant Experience and Key Personnel

In the Management Area, the Offeror should provide at least three references or name contracts demonstrating that it successfully provided services/products that are the same or similar to those required in the RFP. The proposal should adequately explain how the projects were completed on schedule and within budget. It is highly recommended that the Offeror provide sufficient content and detail to answer completely the following questions.

1. Does the proposal include at least three references or past performance citations?
2. Are the references or past performance citations relevant to the requirements of the Statement of Work of the RFP?
3. Does the Offeror explain how they were successful on the projects provided as past performance?
4. Does the Offeror apply the past performance to the City requirement in such a way as to demonstrate added value due to experience?

C. Key Personnel

In the Management Area, resumes must be provided for all personnel considered key, as required by the RFP. Resumes do not count toward the page limit. It is highly recommended that the Offeror provide sufficient content and detail to answer completely the following questions. Explain how the key personnel were related to the projects cited as relevant past performance.

1. Does the Offeror provide complete resumes, including education, experience, background information, accomplishments, and other pertinent information?
2. Does the Offeror provide resumes for all key personnel, as required by the RFP?
3. Do the resumes demonstrate adequate professional, technical, and management levels to accomplish the work effectively and efficiently?

2.6 PRICE AREA

In the Price Area, the Offeror should provide a detailed breakdown of the price for each year of performance. The price must be all-inclusive and include all unit costs for material, labor, other direct costs (e.g. travel), indirect costs (i.e. overhead and general and administrative costs), and profit/fee. Offers must include sufficient detail to allow insight into the fairness and reasonableness of the price. If the contract type will be Time and Material (T&M) labor categories, labor rates, separated profit, and estimated material costs must be included in detail.



In addition, although price may not be the most important factor, it is still very important to the City of Colorado Springs. The Offeror's pricing must be competitive as compared to the budget amount, market pricing in the industry, and the pricing of other Offerors. It is highly recommended that the Offeror provide sufficient content and detail to answer completely the following questions.

1. How does the price compare to the industry competition?
2. If low, is it unrealistically low?
3. If high, is there demonstrated added value for the additional cost?

2.7 PROPOSAL PRESENTATION

Presentation is an important factor. Offerors should provide a highly professional product, which is complete, accurate, easily understood, and effectively presented.

2.8 EXCEPTIONS

All Offerors must complete Exhibit 1, Qualifications Document and return it with their proposal. Some terms and conditions are not negotiable. Exceptions may be grounds for rendering the proposal unacceptable without further discussions.

2.9 INSURANCE REQUIREMENTS

All Offerors must complete Exhibit 1, Qualifications Document and return with their proposal. Lack of responsiveness in this area may be grounds for rendering the proposal unacceptable without further discussions.



SECTION III – EVALUATION FACTORS

3.0 EVALUATION AND AWARD

Section III provides information regarding evaluation criteria and scoring. It also includes information regarding proposal selection and award of the resultant contract.

3.1 EVALUATION CRITERIA

3.1.1 TECHNICAL AREA – UNDERSTANDING OF AND COMPLIANCE WITH TECHNICAL REQUIREMENTS

See Section II - Item 2.5.1A

3.1.2 TECHNICAL AREA – PROJECT APPROACH

See Section II - Item 2.5.1B

3.1.3 MANAGEMENT AREA – PROGRAM MANAGEMENT CONTROLS

See Section II - Item 2.5.2A

3.1.4 MANAGEMENT AREA – PAST PERFORMANCE/RELEVANT EXPERIENCE/KEY PERSONNEL

See Section II – Item 2.5.2B

3.1.5 PRICE/COST AREA – PRICE/COST

See Section II – Item 2.6

3.1.6 PROPOSAL PRESENTATION AREA – PROPOSAL PRESENTATION

See Section II – Item 2.7

3.1.7 EXCEPTIONS AND INSURANCE

See Section II – Items 2.8 and 2.9

3.2 RANKING

A. The order of ranking or importance in the evaluation shall be as follows:

First: Price/Cost Area
Second: Technical Area
Third: Management Area
Fourth: Proposal Presentation Area

B. Possible scores for each criterion shall be as follows:

5 – Exceptional
4 – Very Good
3 – Satisfactory
2 – Marginal
1 – Unacceptable



C. Definitions for scoring are as follows:

Exceptional – The proposal meets all and exceeds many of the requirements of the RFP to the benefit of the City, and the information provided is of such a nature as to answer all questions without need for further inquiry. There are no corrective actions required, and no compromise of requirements is needed.

Very Good – The proposal meets all and exceeds some of the requirements of the RFP to the benefit of the City, and the information provided is of such a nature as to answer most questions without need for further inquiry. There are no corrective actions required, and no compromise of requirements is needed.

Satisfactory – The proposal meets the requirements of the RFP, and the information provided is of such a nature as to answer many questions without need for further inquiry. There are very few corrective actions required, and no substantive compromise of requirements is needed.

Marginal – The proposal does not meet some of the requirements of the RFP, and the information provided is of such a nature as to require some clarification. There are some corrective actions required, and some non-substantive compromise of requirements is needed.

Unacceptable – The proposal does not meet many of the requirements of the RFP, and the information provided is of such a nature as to require much clarification. There are many corrective actions required, and substantive compromise of requirements is needed.

D. Area Scoring

The score for each area will be determined by multiplying the sum of the criteria in each area by the area evaluation factor. The area evaluation factors are as follows:

Price/Cost Area: .60
Technical Area: .20
Management Area: .15
Proposal Presentation Area: .05

E. Final/Overall Scoring

The final proposal score will be determined by adding the area scoring. The sum of the area scores will be the final/overall score.

3.3 SELECTION COMMITTEE

A selection committee will review all proposals. Through this process, the City will determine which proposals are acceptable or unacceptable. The City will notify, in writing, the Offerors whose proposals are deemed to be unacceptable. Those Offerors offering proposals deemed to be acceptable by the City will be evaluated and scored by the selection committee. This scoring will determine which Offerors are considered to be in the competitive range and may be the basis for an award decision without further steps.



If the selection committee elects not to award based upon evaluation scoring, it may engage in a forced elimination process. To inform this process, it may require oral presentations or interviews with the Offerors considered to be in the competitive range. If oral presentations or interviews are conducted, they may also be scored, or they may simply be considered as information supporting the forced elimination process. The selection committee may request revisions to the proposal from each of the Offerors at the conclusion of the interviews. The intent of the forced elimination process is to reach consensus. The decision will be based on all relevant factors, and based upon perception of best value. The final decision may or may not exactly reflect scoring ranking.

The City also reserves the right to request best and final offers from all Offerors at any point in the proposal evaluation process.

3.4 AWARD OF CONTRACT

It is anticipated that there will be negotiations or discussions with Offerors. However, the City reserves the right to award without negotiations or discussions. The City also reserves the right to award a contract not necessarily or merely to the Offeror with the most advantageous price. The City intends to award to the Offeror that demonstrates the best value to the City and the most substantiated ability to fulfill the requirements contained in this Request for Proposal. A contract prepared by the City will be finalized and/or negotiated with the successful Offeror. In the event a contract cannot be negotiated with the top ranked Offeror, the City may enter into negotiations with the second highest ranked Offeror, or the City may decide to call for new proposals. Immediately after the notice of award, the successful Offeror will begin planning in conjunction with the City of Colorado Springs staff (to be designated by the City) to ensure fulfillment of all its obligations. The successful Offeror may be expected to attend regular meetings as required by the City to assist in the preparation for startup.



SECTION IV – SPECIAL CONTRACT TERMS AND CONDITIONS

4.0 SPECIAL CONTRACT TERMS AND CONDITIONS/SPECIAL SOLICITATION PROVISIONS

In addition to the special contract terms and conditions listed below, the City's sample contract, see Exhibit 2, contains contract terms and conditions.

ADA Standards: It is a requirement of the City and required by law that any new or renovated facility meet the scoping and technical requirements of the 2010 ADA Standards for newly designed and constructed or altered local government facilities, public accommodations, and facilities. The selected Design Professional shall design the project so it both conforms to the 2010 ADA Standards, as applicable and as amended, and is readily accessible to and usable by individuals with disabilities. The selected Contractor shall build the project so it both conforms to the 2010 ADA Standards, as applicable and as amended, and is readily accessible to and usable by individuals with disabilities. Facilities that are designed, constructed, and/or altered facilities that meet or exceed the IBC 2015/ANSI A117.1 2009, used by Pikes Peak Regional Building Department, will be accepted as meeting or exceeding the 2010 ADA Standards.



SECTION V – EXHIBITS

5.0 EXHIBITS

Exhibit 1	Qualifications Document
Exhibit 2	Sample Contract
Exhibit 3	Evaluation Scoresheet
Exhibit 4	Sample Bonds



EXHIBIT 1 QUALIFICATIONS DOCUMENT

Will follow this page.



SOLICITATION QUALIFICATIONS DOCUMENTS

Please complete all sections of this document including the Solicitation Certification, Representations and Certifications, Qualification Statement, Exceptions, Minimum Insurance Requirements, and Signature Page.

Please submit all completed documents with your bid/ proposal and sign the Minimum Insurance Requirements and Signature Page.

Solicitation:

Solicitation Number:

Firm Name:

Date:

Address:

Federal Tax ID #:

Tax Classification:

Sole Proprietorship

Partnership

C Corporation

S Corporation

LLC

Nonprofit

DUNS Number:

OFFEROR REPRESENTATIVE

Offeror has appointed the following as the offeror's representative and contact for all questions or clarifications in regard to this offeror.

Name:

Telephone:

E-mail:



SOLICITATION CERTIFICATION

PLACE OF BUSINESS

Company's Principal Place of Business

Does Offeror Have an established office or facility in Colorado Springs? YES NO

If Yes, Indicate address below if different from principal place of business.

Year Facility Was Established

Percent of Work to be performed from principal place of business.

Percent of Work to be performed from Colorado Springs Facility

INSURANCE

Indicate your ability to provide a certificate of insurance evidencing the required coverage types and limits specified in Minimum Insurance Requirements Exhibit. (The certificate of insurance must reflect the City of Colorado Springs as an Additional Insured, as applicable.)

Initial Here

Indicate your Ability to Comply with the following requirements:

The City shall be added as an Additional Insured to all liability policies

YES

NO



Your property and liability insurance company is licensed to do business in Colorado

YES

NO

Your property and liability insurance company has an AM best rating of not less than B+ and/or VII

YES

NO

Worker's Compensation Insurance is carried for all employees and covers work done in Colorado.

YES

NO

Provide the name of your property and liability insurance company here:

FINANCIAL STATEMENTS

Current Financial Statements are not required for this solicitation.

Current Financial Statements are required for this solicitation. Please include financial statements as a separate document with your proposal.

Initial Here

COMPLETED PROPOSAL

Provide the completed and signed proposal. (Proposals must be identified as specified in this RFP document). All required Exhibits are attached.

Initial Here



REPRESENTATIONS AND CERTIFICATIONS

1. INSURANCE REQUIREMENTS

Offeror shall comply with all insurance requirements and will submit the Insurance Certificates prior to performance start date. If limits are different from the stated amounts, Offeror shall explain variance. Certain endorsements and “additionally insured” statements may require further clarification and specific statements on a project specific basis and should have been described in the Offeror’s proposal.

Initial Here #1

2. ETHICS VIOLATIONS

- a) The Offeror shall have in place and follow reasonable procedures designed to prevent and detect possible violations described in this clause in its own operations and direct business relationships.
- b) Offeror certifies the Offeror has not violated or caused any person to violate, and shall not violate or cause any person to violate, the City’s Code of Ethics contained in Article 3, of Chapter 1 of the City Code and in the City’s Procurement Rules and Regulations
- c) When the Offeror has reasonable grounds to believe that a violation described in this clause may have occurred, the Offeror shall promptly report the possible violation to the City Contracts Specialist in writing.
- d) The Offeror must disclose with the signing of this proposal, the name of any officer, director, or agent who is also an employee of the City and any City employee who owns, directly or indirectly, an interest of ten percent (10%) or more in the Offeror’s firm or any of its branches.
- e) In addition, the Offeror must report any conflict or apparent conflict, current or discovered during the performance of the Contract, to the City Contracts Specialist.
- f) The Offeror shall not engage in providing gifts, meals or other amenities to City employees. The right of the Offeror to proceed may be terminated by written notice issued by City Contracts Specialist if Offeror offered or gave a gratuity to an officer, official, or employee of the City and intended by the gratuity to obtain a contract or favorable treatment under a contract.
- g) The Offeror shall cooperate fully with the City or any agency investigating a possible violation on behalf of the City. If any violation is determined, the Offeror will properly compensate the City.
- h) The Offeror agrees to incorporate the substance of this clause (after substituting “Contractor” for “Offeror”) in all subcontracts under this offer.

Initial Here #2



3. COOPERATION WITH OTHER CONTRACTORS

Other City activities/contracts may be in progress or start during the performance of this contract. The Offeror shall coordinate the work harmoniously with the other contractors or City personnel, if applicable.

Initial Here #3

4. INTERNET USE

Should the Offeror require access to City Internet resources in the performance of this requirement, a "Contractor's Internet Use Agreement" form must be separately signed by each individual having access to the City Network. The completed Contractor's Internet Use Agreement will be maintained with this agreement. Inappropriate use of the City Network will be grounds for immediate termination of any awarded contact.

Initial Here #4

5. LITIGATION

If awarded a contract, Offeror shall notify the City within five (5) calendar days after being served with a summons, complaint, or other pleading in any matter which has been filed in any federal or state court or administrative agency. The Offeror shall deliver copies of such document(s) to the City's Procurement Services Manager. The term "litigation" includes an assignment for the benefit of creditors, and filings of bankruptcy, reorganization and/or foreclosure.

Initial Here #5

6. CONTRACTOR'S REGISTRATION INFORMATION

Offeror's firm verifies and states that they are (check all that apply):

Large Business (i.e. do not qualify as a small business or non-profit)

Nonprofit

Small Business

Minority Owned Business/Small Disadvantaged Business

Woman Owned Business



Veteran Owned Business

Service-Disabled Veteran Owned Business

HUBZone Business

Note: The City accepts self-certification for these categories in accordance with Small Business Administration (SBA) standards. The SBA size standards are found on the SBA website <https://www.sba.gov/content/am-i-small-business-concern>.

Initial Here #6

7. CONTRACTOR PERSONNEL

- a) The Offeror shall appoint one of its key personnel as the “Authorized Representative” who shall have the power and authority to interface with the City and represent the Offeror in all administrative matters concerning this proposal and any awarded contract, including without limitation such administrative matters as correction of problems modifications, and reduction of costs.
- b) The Authorized Representative shall be the person identified in the Offeror’s proposal, unless the Offeror provides written notice to the City naming another person to serve as its Authorized Representative. Communications received by the City Contracts Specialist from the Authorized Representative shall be deemed to have been received from the Offeror.

Name:

Telephone:

E-mail:

Initial Here #7

8. OFFEROR’S CERTIFICATION

The undersigned hereby affirms that:

- a) He/She is a duly authorized agent of the Offeror;
- b) He/She has read and agrees to the City’s standard terms and conditions attached.
- c) The offer is presented in full compliance with the collusive prohibitions of the City of Colorado Springs. The Offeror certifies that no employee of its firm has discussed, or



compared the offer with any other offeror or City employee and has not colluded with any other offeror or City employee.

- d) The Offeror certifies that it has checked all of its figures, and understands that the City will not be responsible for any errors or omissions on the part of the Offeror in preparing its proposal.
- e) By submitting an offer the Offeror certifies that it has complied and will comply with all requirements of local, state, and federal laws, and that no legal requirements have been or will be violated in making or accepting this solicitation.

I hereby certify that I am submitting the proposal based on my company's capabilities to provide quality products and/or services on time.

Initial Here #8

9. OFFEROR CERTIFICATION REGARDING DEBARMENT, SUSPENSION, PROPOSED DEBARMENT, AND OTHER RESPONSIBILITY MATTERS:

- 1. The Offeror certifies to the best of its knowledge and belief, that (i) the Offeror and/or any of its Principals

Are Are Not

Presently debarred, suspended, proposed for debarment, or declared ineligible for the award of contracts by any Federal agency.

Have Have Not

Within a three year period preceding this offer, been convicted of or had a civil judgment rendered against them for: commission of fraud or a criminal offense in connection with obtaining, attempting to obtain, or performing a public (federal, state, local) contract or subcontract; violation of Federal or state antitrust statutes relation to the submission of offers; or commission of embezzlement, theft, forgery, bribery, falsification or destruction of records, making false statement, tax evasion, or receiving stolen property; and

Are Are Not

presently indicated for, or otherwise criminally or civilly charged by a governmental entity with commission of any of the offenses enumerated in any paragraphs above.

- 2. The Offeror shall provide immediate written notice to the City Contracts Specialist if, at any time prior to contract award, the Offeror learns that its certification was erroneous when submitted or has become erroneous by reasons of changed circumstances.
- 3. The certification in paragraph 1. above, is a material representation of fact upon which reliance was placed when making award. If it is later determined that the Offeror knowingly rendered an erroneous certification, in addition to other remedies available to the City, the



City Contracts Specialist may terminate the contract resulting from this solicitation for default. Termination for default may result in additional charges being levied for the costs incurred by the City to initiate activities to replace the awarded Contractor.

Initial Here #9

10. ACCEPTANCE OF CITY CONTRACTS SPECIALIST'S SOLE AUTHORITY FOR CHANGES

Unless otherwise specified in the Contract, the Offeror hereby agrees that any changes to the scope of work, subsequent to the original contract signing, shall be generated in writing and an approval signature shall be obtained from the City Contracts Specialist prior to additional work performance.

Initial Here #10

11. CITY CONTRACTOR SAFETY PROGRAM

The Offeror hereby agrees to adhere to a worker safety program for contractor employees on a City job site or location. By initialing below, the Offeror has reviewed the information and will abide by the City Policy which is available for review:

<https://coloradosprings.gov/finance/page/procurement-regulations-and-documents>

Initial Here #11

12. ACCEPTANCE OF CITY ENVIRONMENTALLY PREFERRED PURCHASING (EPP) POLICY

The City of Colorado Springs is committed to buying more environmentally preferable goods and services, as long as they meet performance needs, are available within a reasonable time and at a reasonable cost. The Offeror hereby acknowledges review of this policy by initialing below.

<https://coloradosprings.gov/finance/page/procurement-regulations-and-documents>

Initial Here #12



13. FRAUD, WASTE, AND ABUSE

Everyone has a duty to report any suspected unlawful act impacting the City of Colorado Springs operations and its enterprises. Anyone who becomes aware of the existence or apparent existence of fraud, waste, and abuse in City of Colorado Springs is encouraged to report such matters to the City Auditor's Office in writing or on the telephone hotline 385-2387 (ADTR). Written correspondence can be mailed to:

City Auditor

P.O. Box 2241

Colorado Springs CO 80901

Or via email FraudHotline@ColoradoSprings.gov. Any of these mechanisms allow for anonymous reporting. For more information, please go to the website <https://coloradosprings.gov/cityfraud>.

Initial Here #13



QUALIFICATION STATEMENT

This statement will provide information which will enable the City to evaluate the qualifications of your firm and staff with regard to the requirements of this solicitation. Please complete this form in its entirety. If a request in the Qualification Statement is contained in the proposal, indicate the section in the proposal where that information can be found.

1. TYPE OF LICENSE(S) HELD

2. TYPE OF SERVICE TO BE PROVIDED FOR THIS SOLICITATION

3. NUMBER OF YEARS IN BUSINESS

4. FIRM HISTORY & STAFF QUALIFICATIONS

In your proposal provide a brief history of your firm, staff size, and experience. Submit a resume for the project manager and each key personnel assigned to this project.

5. WHAT OTHER NAME(S) HAS YOUR COMPANY OPERATED UNDER

My Firm has not operated under any other names

6. HAVE YOU OR YOUR FIRM EVER FAILED TO COMPLETE ANY WORK AWARDED TO YOU?

Yes No

If Yes, Please Explain



7. HAS ANY OFFICER OF PARTNER OF YOUR ORGANIZATION EVER BEEN AN OFFICER OR PARTNER OF ANOTHER ORGANIZATION THAT FIALED TO COMPLETE A CONTRACT WITHIN THE LAST FIVE (5) YEARS?

Yes No

If Yes, Please Explain

8. HAS YOUR FIRM OR ANY PARTNERS OR OFFICERS EVER BEEN INVOLVED IN ANY BANKRUPTCY ACTION?

Yes No

If Yes, Please Explain

9. ARE YOU PRESENTLY INVOLVED IN ANY LITIGATION WITH ANY GOVERNMENT AGENCY?

Yes No

If Yes, Please Explain Type, Kind, Plaintiff, Defendant, etc. and state the current status:

10. BANK REFERENCE

Bank Name:

Address:

Contact:

Phone #:

E-mail:



11. SIMILAR PROJECTS

List Three similar projects (local or state-wide) from the last five (5) years. Include the location of the project, size of project (contract amount), contract name and information.

NOTE: Detailed information on these projects may also be requested in the solicitation package

Indicate here if this information is provided within your proposal and identify where in the proposal it is located.

1. Company:

Location of Project:

Contract Amount:

Contract Period of Performance:

Company Representative:

Representative's Title:

Representative's Address:

Representative's Phone #:

Representative's E-mail:

Brief Description of service/goods provided and how your firm was successful carrying out the scope of work of the contract.

2. Company:

Location of Project:

Contract Amount:

Contract Period of Performance:

Company Representative:



Representative's Title:

Representative's Address:

Representative's Phone #:

Representative's E-mail:

Brief Description of service/goods provided and how your firm was successful carrying out the scope of work of the contract.

3. Company:

Location of Project:

Contract Amount:

Contract Period of Performance:

Company Representative:

Representative's Title:

Representative's Address:

Representative's Phone #:

Representative's E-mail:

Brief Description of service/goods provided and how your firm was successful carrying out the scope of work of the contract.



12. SIMILAR PROJECTS CURRENTLY UNDER CONTRACT

list three projects currently under contract and in progress (local or state-wide) from the last five (5) years. Include the location of the project, size of project (contract amount), contract name and information. NOTE: Detailed information on these projects may also be requested in the solicitation package

Indicate here if this information is provided within your proposal and identify where in the proposal it is located.

1. Company:

Location of Project:

Contract Amount:

Contract Period of Performance:

Company Representative:

Representative's Title:

Representative's Address:

Representative's Phone #:

Representative's E-mail:

Brief Description of service/goods provided.

2. Company:

Location of Project:

Contract Amount:

Contract Period of Performance:

Company Representative:



Representative's Title:

Representative's Address:

Representative's Phone #:

Representative's E-mail:

Brief Description of service/goods provided.

3. Company:

Location of Project:

Contract Amount:

Contract Period of Performance:

Company Representative:

Representative's Title:

Representative's Address:

Representative's Phone #:

Representative's E-mail:

Brief Description of service/goods provided.



13. ADDITIONAL QUALIFICATION REQUIREMENTS

There are no additional qualification requirements for this solicitation.

There are additional qualification requirements as follows:



EXCEPTIONS

Please Indicate below if there are any exceptions taken to any of the terms, conditions, or specifications of these proposal documents or contract.

If there are exceptions taken to any of the terms, conditions, or specifications of the proposal document or contract, they must be clearly stated on an additional document attached to this exhibit and returned with your proposal.

NOTE: All potential Offerors are hereby advised that exceptions taken may be considered during the evaluation phase which may affect the final scoring of proposals. Offerors stipulating that the City must use their contract or agreement may be determined non-responsive and their Proposal determined unacceptable.

Please indicate below:

My Firm has no exceptions.

My Firm does have exceptions. (Attach Exceptions to this exhibit)



MINIMUM INSURANCE REQUIREMENTS

The following listed minimum insurance requirements shall be carried by all contractors and consultants unless otherwise specified in the City's solicitation package, Special Provisions or Standard Specifications.

- Commercial General Liability for limits not less than \$1,000,000 combined single limit with \$2,000,000 aggregate for bodily injury and property damage for each occurrence. Coverage shall include blanket contractual, broad form property damage, products and completed operations.
- Workers' Compensation and Employers Liability as required by statute. Employers Liability coverage is to be carried for a minimum limit of \$1,000,000.
- Automobile Liability covering any auto (including owned, hired, and non-owned autos) with a minimum of \$1,000,000 each accident combined single limit.
- Professional Liability Insurance covering any damages caused by an error, omission or any negligent acts with limits of not less than \$2,000,000 per occurrence and in the aggregate.
 - In the event that any professional liability insurance required by this Contract is written on a claims-made basis, Consultant warrants that any retroactive date under the policy shall precede the effective date of this Contract; and that either continuous coverage will be maintained or an extended discovery period will be exercised for a period of three (3) years beginning at the time work under this Contract is completed
 - Policy shall contain a waiver of subrogation against the CITY.
- Pollution Legal Liability Insurance shall apply to sudden and gradual pollution conditions resulting from the escape or release of smoke, vapors, fumes, acids, alkalis, toxic chemicals, liquids, or gases, natural gas, waste materials, or other irritants, contaminants, or pollutants (including asbestos). If the coverage is written on a claims-made basis, the Contractor warrants that any retroactive date applicable to coverage under the policy precedes the effective date of this Contract; and that continuous coverage will be maintained or an extended discovery period will be exercised for a period of three (3) years beginning from the time that work under this contract is completed. Policy limits shall be no less than \$1,000,000 per loss with \$2,000,000 aggregate coverage.

Except for workers' compensation and employer's liability insurance and Professional Liability, the City of Colorado Springs must be named as an additional insured. Certificates of Insurance must be submitted before commencing the work and provide 30 days' notice prior to any cancellation, non-renewal, or material changes to policies required under the contract.

Name of Company

Signature

Date



SIGNATURE PAGE

By signing below, the Offeror certifies that no person or firm other than the Offeror or as otherwise indicated has any interest whatsoever in this offer or any Contract that may be entered into as a result of this offer and that in all respects the offer is legal and firm, submitted in good faith without collusion or fraud.

The undersigned additionally declares that it has carefully examined the Bid/Proposal information and the complete Solicitation prior to submitting a Bid / Proposal. The Offeror's signature will be considered the Offeror's acknowledgement of understanding and ability to comply with all items in the solicitation.

The undersigned acknowledges and understands the terms, conditions, Specifications and all Requirements contained and/or referenced and are legally authorized by the Offeror to make the above statements or representations.

Signature

Name (Printed)

Company Name

Title

Date



**EXHIBIT 2 SAMPLE CONTRACT
CONSTRUCTION CONTRACT**

Contract Number:		Project Name/Title	
Vendor/Contractor			
Contact Name:		Telephone:	
Email Address:			
Address:			
Federal Tax ID #		Please check one:	<input type="checkbox"/> Corporation <input type="checkbox"/> Individual <input type="checkbox"/> Partnership
City Contracting Specialist			
		City Dept Rep	
NOT TO EXCEED Contract Amount:		City Account #	
Contract Type:	Fixed Unit Price	Period of Performance:	

1. INTRODUCTION

THIS Fixed Unit Price CONTRACT ("Contract") is made and entered into this XXX day of XXX, 2022 by and between the City of Colorado Springs, a Colorado municipal corporation and home rule city, in the County of El Paso, State of Colorado, (the "City"), and _____ (the "Contractor").

THE CITY AND THE CONTRACTOR HEREBY AGREE AS FOLLOWS:

The City has heretofore prepared the necessary Contract Documents for the following Activity: XXXX.

The Contractor did on the XXX day of XXX, 2022 submit to the City the Contractor's written offer and proposal to do the work therein described under the terms and conditions therein set forth and furnish all materials, supplies, labor, services, transportation, tools, equipment, and parts for said work in strict conformity with the accompanying Contract Documents, which are attached hereto and incorporated herein by this reference, including the following:

1. This Contract
2. Schedule A – Price Sheet
3. Schedule B – General Construction Terms and Conditions
4. Schedule C – Special Contract Terms and Conditions
5. Schedule D – General Specifications
6. Schedule E – Special and Technical Specifications
7. Schedule F – Scope of Work
8. Exhibit 1 – Performance, Labor and Material Payment, and Maintenance Bonds
9. Exhibit 2 – Minimum Insurance Requirements



2. COMPENSATION/CONSIDERATION

THIS FIXED UNIT PRICE CONTRACT is established at the Not to Exceed amount of \$xxxxxxx.

Subject to the terms and conditions of the Contract Documents, Contractor agrees to furnish all materials and to perform all work as set forth in its proposal and as required by the Contract Documents.

All pricing is in accordance with the fixed unit prices found in Schedule A, as proposed by the Contractor. Payment made for actual quantities as set forth in Schedule B, General Construction Terms and Conditions. At no time shall the total obligation of the City exceed the not to exceed amount of this Contract.

3. TERM OF CONTRACT

Contractor will start work promptly after the Notice to Proceed and continue to work diligently until completed. The Contractor shall complete all work on an as ordered basis throughout the Contract period which is **XXX calendar days from Issuance of Notice to Proceed** ("Period of Performance") as per the specifications and drawings. The Contractor shall provide a two-year guarantee on all work performed under this Contract after the job has been completed and accepted.

4. INSURANCE

The Contractor shall provide and maintain acceptable Insurance Policy(s) consistent with the Minimum Insurance Requirements attached as Exhibit 2, which includes Property, Liability, and as otherwise listed in Exhibit 2. The City of Colorado Springs shall be reflected as an additional insured on the Property and Liability policy(s).

Further, Contractor understands and agrees that Contractor shall have no right of coverage under any existing or future City comprehensive, self, or personal injury policies. Contractor shall provide insurance coverage for and on behalf of Contract that will sufficiently protect Contractor, or Contractor's agents, employees, servants or other personnel, in connection with the services which are to be provided by Contractor pursuant to this Contract, including protection from claims for bodily injury, death, property damage, and lost income. Contractor shall provide worker's compensation insurance coverage for Contractor and all Contractor personnel. Contractor shall file applicable insurance certificates with the City and shall also provide additional insurance as indicated in this Contract. ***A CURRENT CERTIFICATE OF INSURANCE IS REQUIRED PRIOR TO COMMENCEMENT OF SERVICES LISTING THE CITY AS ADDITIONALLY INSURED.***

5. RESPONSIBILITY OF THE CONTRACTOR

- A. The Contractor shall be responsible for the professional quality, technical accuracy, and the coordination of all Scope of Work services furnished by the Contractor under this Contract. The Contractor shall, without additional compensation, correct or revise any errors or deficiencies in services provided under this Contract to the satisfaction of the City.
- B. The City's review, approval of, acceptance of, or payment for the services required under this Contract shall not be construed to operate as a waiver of any rights under this Contract or of



any cause of action arising out of the performance of this Contract, and the Contractor shall be and remain liable to the City for any and all damages to the City caused by the Contractor's negligent performance of any of the services furnished under this Contract.

- C. The rights and remedies of the City provided for under this Contract are in addition to any other rights and remedies provided by law.
- D. If the Contractor is comprised of more than one legal entity, each such entity shall be jointly and severally liable hereunder.

6. WORK OVERSIGHT

- A. The extent and character of the work to be done by the Contractor shall be subject to the general approval of the City's delegated Project Manager.
- B. If any of the work or services being performed does not conform with Contract requirements, the City may require the Contractor to perform the work or services again in conformity with Contract requirements, at no increase in Contract amount. When defects in work or services cannot be corrected by re-performance, the City may (1) require the Contractor to take necessary action to ensure that future performance conforms to Contract requirements and (2) reduce the Contract price to reflect the reduced value of the work or services performed.
- C. If the Contractor fails to promptly perform the defective work or services again or to take the necessary action to ensure future performance is in conformity with Contract requirements, the City may (1) by Contract or otherwise, perform the services and charge to the Contractor any cost incurred by the City that is directly related to the performance of such work or service or (2) terminate the Contract for breach of contract.

7. SUBCONTRACTORS, ASSOCIATES, AND OTHER CONTRACTORS

- A. Any subcontractor, outside associates, or other contractors used by the Contractor in connection with Contractor's work under this Contract shall be limited to individuals or firms that are specifically identified by the Contractor in the Contractor's proposal and agreed to by the City. The Contractor shall obtain the City's Project Manager's written consent before making any substitution of these subcontractors, associates, or other contractors.
- B. The Contractor shall include a flow down clause in all of its subcontracts, agreements with outside associates, and agreements with other contractors. The flow down clause shall cause all of the terms and conditions of this Contract, including all of the applicable parts of the Contract Documents, to be incorporated into all subcontracts, agreements with outside associates, and agreements with other contractors. The flow down clause shall provide clearly that there is no privity of contract between the City and the Contractor's subcontractors, outside associates, and other contractors.

8. KEY PERSONNEL

The key personnel listed in the proposal and/or below will be the individuals used in the performance of the work. If any of the listed key personnel leave employment or are otherwise not utilized in the performance of the work, approval to substitute must be obtained by the



Contractor from the City's Project Manager. Any substitute shall have the same or a higher standard of qualifications that the key personnel possessed at the time of Contract award.

9. START AND CONTINUANCE OF WORK

It is further agreed that the Contractor will start work promptly and continue to work diligently until this Contract is completed.

10. APPROPRIATION OF FUNDS

This Contract is expressly made subject to the limitations of the Colorado Constitution and Section 7-60 of the Charter of the City of Colorado Springs. Nothing herein shall constitute, nor be deemed to constitute, the creation of a debt or multi-year fiscal obligation or an obligation of future appropriations by the City Council of Colorado Springs, contrary to Article X, § 20, Colo. Const., or any other constitutional, statutory, or charter debt limitation. Notwithstanding any other provision of this Contract, with respect to any financial obligation of the City which may arise under this Agreement in any fiscal year after the year of execution, in the event the budget or other means of appropriation for any such year fails to provide funds in sufficient amounts to discharge such obligation, such failure (i) shall act to terminate this Contract at such time as the then-existing and available appropriations are depleted, and (ii) neither such failure nor termination shall constitute a default or breach of this Contract, including any sub-agreement, attachment, schedule, or exhibit thereto, by the City. As used herein, the term "appropriation" shall mean and include the due adoption of an appropriation ordinance and budget and the approval of a Budget Detail Report (Resource Allocations) which contains an allocation of sufficient funds for the performance of fiscal obligations arising under this Contract.

11. CHANGES

The Contractor and the City agree and acknowledge as a part of this Contract that no change order or other form or order or directive may be issued by the City which requires additional compensable work to be performed, which work causes the aggregate amount payable under the Contract to exceed the amount appropriated for this Contract as listed above, unless the Contractor has been given a written assurance by the City that lawful appropriations to cover the costs of the additional work have been made or unless such work is covered under a remedy-granting provision of this Contract. The Contractor and the City further agree and acknowledge as a part of this Contract that no change order or other form or order or directive which requires additional compensable work to be performed under this Contract shall be issued by the City unless funds are available to pay such additional costs, and, regardless of any remedy-granting provision included within this Contract, the Contractor shall not be entitled to any additional compensation for any change which increases or decreases the Contract completion date, or for any additional compensable work performed under this Contract, and expressly waives any rights to additional compensation, whether by law or equity, unless, prior to commencing the additional work, the Contractor is given a written change order describing the change in Contract completion date or the additional compensable work to be performed, and setting forth the amount of compensation to be paid, and such change order is signed by the authorized City representative, as defined below. The amount of compensation to be paid, if any, shall be deemed to cover any and all additional, direct, indirect or other cost or expense or profit of the Contractor whatsoever. It is the Contractor's sole responsibility to know, determine, and ascertain the authority of the City representative signing any change order under this Contract.



No change, amendment, or modification to this Contract shall be valid unless duly approved and issued in writing by the City of Colorado Springs Procurement Services Division. The City shall not be liable for any costs incurred by the Contractor resulting from work performed for changes not issued in writing by the City of Colorado Springs Procurement Services Division.

The following personnel are authorized to sign changes, amendments, or modifications to this Contract.

The Department Manager: up to \$149,999.99

The City of Colorado Springs Deputy Chief of Staff: \$150,000.00 to \$499,999.99

The City of Colorado Springs Chief of Staff: \$500,000.00 to \$1,999,999.99

The Mayor of Colorado Springs: Unlimited

12. ECONOMIC PRICE ADJUSTMENT

- A. The Contractor shall notify the City of Colorado Springs Procurement Services Division if, at any time during contract performance, the rate of pay for labor or the unit prices for material shown in Schedule A experiences a significant increase. A change in price shall be considered significant when the unit price of an item increases by 10% from the execution date of this Contract. The Contractor shall furnish notice of this increase within 60 days after the increase, or within any additional period that the City Procurement Services Division may approve in writing, but not later than the date of final payment under this Contract. The notice shall include the Contractor's proposal for an adjustment in the Contract unit prices to be negotiated under paragraph (b) of this clause, and shall include, in the form required by the City Procurement Services Division, supporting data explaining the cause, effective date, and amount of the increase and the amount of the Contractor's adjustment proposal.
- B. Promptly after the City Procurement Services Division receives the notice and data under paragraph (a) of this clause, the City Procurement Services Division and the Contractor shall negotiate a price adjustment in the contract unit prices and its effective date. However, the City Procurement Services Division may postpone the negotiations until an accumulation of increases in the labor rates (including fringe benefits) and unit prices of material shown in Schedule A results in an adjustment allowable under paragraph (c)(3) of this clause. The City Procurement Services Division shall modify this contract (1) to include the price adjustment and its effective date and (2) to revise the labor rates (including fringe benefits) or unit prices of material as shown in Schedule A to reflect the increases resulting from the adjustment. The Contractor shall continue performance at current rates pending agreement on, or determination of, any adjustment and its effective date.
- C. Any price adjustment under this clause is subject to the following limitations:
1. Any adjustment shall be limited to the effect on unit prices of the increases in the rates of pay for labor (including fringe benefits) or unit prices for material shown in Schedule A. There shall be no adjustment for:
 - (i) Supplies or services for which the production cost is not affected by such changes;
 - (ii) Changes in rates or unit prices other than those shown in Schedule A; or
 - (iii) Changes in the quantities of labor or material used from those shown in Schedule A for each item.



2. No upward adjustment shall apply to supplies or services that are required to be delivered or performed before the effective date of the adjustment, unless the Contractor's failure to deliver or perform according to the delivery schedule results from causes beyond the Contractor's control and without its fault or negligence, within the meaning of the Default clause.
3. There shall be no adjustment for any change in rates of pay for labor (including fringe benefits) or unit prices for material which would not result in a net change of at least 3 percent of the then-current total contract price. This limitation shall not apply, however, if, after final delivery of all line items, either party requests an adjustment under paragraph (b) of this clause.
4. The aggregate of the increases in any contract unit price made under this clause shall not exceed 10 percent of the original unit price.

13. ASSIGNMENT

No assignment or transfer by the Contractor of this Contract or any part thereof or of the funds to be received thereunder by the Contractor will be recognized unless such assignment has had the prior written approval of the City and the surety has been given due notice of such assignment. Such written approval by the City shall not relieve the Contractor of the obligations under the terms of this Contract. In addition to the usual recitals in assignment contracts, the following language must be included in the assignment:

It is agreed that the funds to be paid to the assignee under this assignment are subject to a prior lien for services rendered or materials supplied for the performance of the work called for in said contract in favor of all persons, firms, or corporations rendering such services or supplying such materials.

14. CHOICE OF LAW

This Contract is subject to and shall be interpreted under the law of the State of Colorado, and the Charter, City Code, Ordinances, Rules and Regulations of the City of Colorado Springs, Colorado, a Colorado home rule city. Court venue and jurisdiction shall be exclusively in the Colorado District Court for El Paso County, Colorado. The Parties agree that the place of performance for this Contract is deemed to be in the City of Colorado Springs, El Paso County, State of Colorado. The Contractor shall ensure that the Contractor and the Contractor's employees, agents, officers and subcontractors are familiar with, and comply with, applicable Federal, State, and Local laws and regulations as now written or hereafter amended.

15. WORKERS' COMPENSATION INSURANCE

Contractor shall take out and maintain during the Period of Performance, Colorado Worker's Compensation Insurance for the Contractor and all employees of the Contractor. If any service is sublet by the Contractor, the Contractor shall require the subcontractor to provide the same coverage for the subcontractor and subcontractor's employees. Workers' Compensation Insurance shall include occupational disease provisions covering any obligations of the Contractor in accord with the provisions of the Workers' Compensation Act of Colorado.



16. INDEMNIFICATION

Contractor agrees that the Contractor shall indemnify, defend and hold harmless the City, its officers, employees and agents, from and against any and all loss, damage, injuries, claims, cause or causes of action, or any liability whatsoever resulting from, or arising out of, or in connection with the Contractor's obligations or actions under this Contract caused by any willful or negligent error, omission or act or a failure to observe any applicable standard of care by the Contractor or any person employed by it or anyone for whose acts the Contractor is legally liable. In consideration of the award of this Contract, to the extent damages are covered by insurance, the Contractor agrees to waive all rights of subrogation against the City, its subsidiary, parent, associated and/or affiliated entities, successors, or assigns, its elected officials, trustees, employees, agents, and volunteers for losses arising from the work performed by the Contractor for the City. The indemnification obligation shall survive the expiration or termination of this Contract.

17. INDEPENDENT CONTRACTOR

In the performance of the Contractor's obligations under this Contract, it is understood, acknowledged and agreed between the parties that the Contractor is at all times acting and performing as an independent contractor, and the City shall neither have nor exercise any control or direction over the manner and means by which the Contractor performs the Contractor's obligations under this Contract, except as otherwise stated within the Contract terms. The City shall not provide any direction to the Contractor on the work necessary to complete the project. Contractor understands that it is an independent contractor responsible for knowing how to perform all work or tasks necessary to complete project. The Contractor understands and agrees that the Contractor and the Contractor's employees, agents, servants, or other personnel are not City employees. The Contractor shall be solely responsible for payment of salaries, wages, payroll taxes, unemployment benefits or any other form of compensation or benefit to the Contractor or any of the Contractor's employees, agents, servants or other personnel performing services or work under this Contract, whether it is of a direct or indirect nature. Further in that regard, it is expressly understood and agreed that for such purposes neither the Contractor nor the Contractor's employees, agents, servants or other personnel shall be entitled to any City payroll, insurance, unemployment, worker's compensation, retirement or any other benefits whatsoever.

18. APPLICABLE LAW AND LICENSES

In the conduct of the services or work contemplated in this Contract, the Contractor shall ensure that the Contractor and all subcontractors comply with all applicable state, federal and City and local law, rules and regulations, technical standards or specifications. The Contractor shall qualify for and obtain any required licenses prior to commencement of work.

19. PRIOR AGREEMENTS

This is a completely integrated Contract and contains the entire agreement between the parties. Any prior written or oral agreements or representations regarding this Contract shall be of no effect and shall not be binding on the City. This Contract may only be amended in writing, and executed by duly authorized representatives of the parties hereto.



20. INTELLECTUAL PROPERTY

The Parties hereby agree, and acknowledge, that all products, items writings, designs, models, examples, or other work product of the Contractor produced pursuant to this Contract are works made for hire, and that the City owns, has, and possesses any and all ownership rights and interests to any work products of the Contractor made under this Contract, including any and all copyright, trademark, or patent rights, and that compensation to the Contractor for Agreement and acknowledgment of this intellectual property right section of this Contract is included in any compensation or price whatsoever paid to the Contractor under this Contract. It is the intent of the parties that the City shall have full ownership and control of the Contractor's work products produced pursuant to this Contract, and the Contractor specifically waives and assigns to the City all rights which Contractor may have under the 1990 Visual Artists Rights Act, federal, and state law, as now written or later amended or provided. In the event any products, items writings, designs, models, examples, or other work product produced pursuant to this Contract is deemed by a court of competent jurisdiction not to be a work for hire under federal copyright laws, this intellectual property rights provision shall act as an irrevocable assignment to the City by the Contractor of any and all copyrights, trademark rights, or patent rights in the Contractor's products, items writings, designs, models, examples, or other work product produced pursuant to this Contract, including all rights in perpetuity. Under this irrevocable assignment, the Contractor hereby assigns to the City the sole and exclusive right, title, and interest in and to the Contractor's products, items writings, designs, models, examples, or other work product produced pursuant to this Contract, without further consideration, and agrees to assist the City in registering and from time to time enforcing all copyrights and other rights and protections relating to the Contractor's products, items writings, designs, models, examples, or other work product in any and all countries. It is the Contractor's specific intent to assign all right, title, and interest whatsoever in any and all copyright rights in the Contractor's products, items writings, designs, models, examples, or other work product produced pursuant to this Contract, in any media and for any purpose, including all rights of renewal and extension, to the City. To that end, the Contractor agrees to execute and deliver all necessary documents requested by the City in connection therewith and appoints the City as Contractor's agent and attorney-in-fact to act for and in Contractor's behalf and stead to execute, register, and file any such applications, and to do all other lawfully permitted acts to further the registration, prosecution, issuance, renewals, and extensions of copyrights or other protections with the same legal force and effect as if executed by the Contractor; further, the parties expressly agree that the provisions of this intellectual property rights section shall be binding upon the parties and their heirs, legal representatives, successors, and assigns.

21. WAIVERS

No waiver of default by the City of any of the terms, covenants, and conditions hereof to be performed, kept, and observed by the Contractor shall be construed, or shall operate, as a waiver of any subsequent default of any of the terms, covenants, or conditions herein contained to be performed, kept, and observed by the Contractor.

22. THIRD PARTIES

It is expressly understood and agreed that enforcement of the terms and conditions of this Contract, and all rights of action relating to such enforcement, shall be strictly reserved to the Parties hereto, and nothing contained in this Contract shall give or allow any such claim or right



of action by any other or third person or entity on such Contract. It is the express intention of the Parties hereto that any person or entity, other than the Parties to this Contract, receiving services or benefits under this Contract shall be deemed to be incidental beneficiaries only.

23. TERMINATION

A. Termination for Convenience.

By signing this Contract, Contractor represents that it is a sophisticated business and enters into the Contract voluntarily, has calculated all business risks associated with this Contract, and understands and assumes all risks of being terminated for convenience, whether such risks are known or not known. Contractor agrees that the City may terminate this Contract at any time for convenience of the City, upon written notice to the Contractor. Contractor expressly agrees to and assumes the risk that the City shall not be liable for any costs or fees of whatsoever kind and nature if termination for convenience occurs before Contractor begins any work or portion of the work. Contractor further expressly agrees and assumes the risks that the City shall not be liable for any unperformed work, anticipated profits, overhead, mobilizations costs, set-up, demobilization costs, relocation costs of employees, layoffs or severance costs, administrative costs, productivity costs, losses on disposal of equipment or materials, cost associated with the termination of subcontractors, costs associated with purchase orders or purchases, or any other costs or fees of any kind and nature, if Contractor has started or performed portions of the Contract prior to receiving notice from the City. The City shall be liable only for the portions of work Contractor actually satisfactorily completed up to the point of the issuance of the Notice of Termination for convenience. Upon receipt of this notice the Contractor shall immediately: discontinue all services affected (unless the notice directs otherwise), and deliver to the City all data, drawings, specifications, reports, estimates, summaries, and other information and materials accumulated in performing this Contract, whether completed or in process.

B. Termination for Cause: The occurrence of any one or more of the following events (“Event of Default”) will justify termination for cause:

1. Contractor’s failure to perform the work in accordance with the Contract Documents (including, but not limited to, failure to supply sufficient skilled workers or suitable materials or equipment or failure to adhere to the progress schedule as adjusted from time to time.
2. Contractor’s disregard of the laws or regulations of any public body having jurisdiction.
3. Contractor’s disregard of the authority of Project Manager.
4. Contractor’s violation in any material provision of the Contract Documents.
5. Contractor’s failure to make prompt payments to its subcontractors, and suppliers of any tier, or laborers or any person working on the work by, through, or under the Contractor or any of them, any all of their employees, officers, servants, members, and agents.
6. Contractor files a petition commencing a voluntary case under the U.S. Bankruptcy Code, or for liquidation, reorganization, or an arrangement pursuant to any other U.S. or state bankruptcy Laws, or shall be adjudicated a debtor or be declared bankrupt or insolvent under the U.S. Bankruptcy Code, or any other federal or state laws relating to bankruptcy, insolvency, winding-up, or adjustment of debts, or makes a general assignment for the benefit of creditors, or admits in writing its inability to pay its debts generally as they become due, or if a petition commencing an involuntary case under the U.S. Bankruptcy Code or an answer proposing the adjudication of Contractor as a debtor or bankrupt or proposing its liquidation or reorganization pursuant to the Bankruptcy Code or any other



U.S. federal or state bankruptcy laws is filed in any court and Contractor consents to or acquiesces in the filing of that pleading or the petition or answer is not discharged or denied within sixty (60) Calendar Days after it is filed.

7. A custodian, receiver, trustee or liquidator of Contractor, all or substantially all of the assets or business of Contractor, or of Contractor's interest in the Work or the Contract, is appointed in any proceeding brought against Contractor and not discharged within sixty (60) Calendar Days after that appointment, or if Contractor shall consent to or acquiesces in that appointment.
8. Contractor fails to commence correction of defective work or fails to correct defective work within a reasonable period of time after written notice.

If one or more of the events identified in Paragraphs 1-8 above occur, City may give Contractor written notice of the event and direct the event be cured. Any such Notice to Cure will provide Contractor a minimum of ten (10) calendar days to prepare and submit to the Project Manager a plan to correct the Event of Default. If such plan to correct the Event of Default is not submitted to the Project Manager within ten (10) days after the date of the written notice or such plan is unacceptable to the City, the City may, give Contractor (and the Surety, if any) written notice that Contractor's services are being terminated for cause. Upon delivery of the termination notice, City may terminate the services of Contractor in whole or in part, exclude Contractor from the site, and take possession of the work and of all Contractor's tools, appliances, construction equipment, and machinery at the project site, and use the same to the full extent they could be used by Contractor (without liability to Contractor for trespass or conversion), incorporate in the work all materials and equipment stored at the site or for which City has paid Contractor but which are stored elsewhere, and finish the work as City may deem expedient. In such case, Contractor shall not be entitled to receive any further payment until Certificate of Completion of the work. In the event City terminates this Contract for Cause and the cost of completing the work exceeds the unpaid balance of the Contract price, Contractor shall pay City for any costs of completion which exceed the Contract price when combined with all amounts previously paid to Contractor. When exercising any rights or remedies under this paragraph City shall not be required to obtain the lowest price for the work performed. Should the cost of such completion, including all proper charges, be less than the original Contract price, the amount so saved shall accrue to the City. Neither the City nor any officer, agent or employee of the City shall be in any way liable or accountable to the Contractor or the Surety for the method by which the completion of the said work, or any portion thereof, may be accomplished or for the price paid.

Where Contractor's services have been so terminated by City, the termination will not affect any rights or remedies of City against Contractor or Surety then existing or which may thereafter accrue. Any retention or payment of moneys due Contractor by City will not release Contractor from liability.

- C. Termination Notice. Upon receipt of a termination notice, whether for convenience or cause, the Contractor shall immediately: discontinue all services affected (unless the notice directs otherwise), and deliver to the City all data, drawings, specifications, reports, estimates, summaries, and other information and materials accumulated in performing this Contract, whether completed or in process.
- D. Removal of Equipment. Except as provided above, in the case of termination of this Contract before completion from any cause whatever, the Contractor, if notified to do so by the City,



shall promptly remove any part or all of Contractor's equipment and supplies from the property of the City, failing which the City shall have the right to remove such equipment and supplies at the expense of the Contractor.

24. BOOKS OF ACCOUNT AND AUDITING

The Contractor shall make available to the City if requested, true and complete records, which support billing statements, reports, performance indices, and all other related documentation. The City's authorized representatives shall have access during reasonable hours to all records, which are deemed appropriate to auditing billing statements, reports, performance indices, and all other related documentation. The Contractor agrees that it will keep and preserve for at least seven years all documents related to the Contract which are routinely prepared, collected or compiled by the Contractor during the performance of this Contract.

The City's Auditor and the Auditor's authorized representatives shall have the right at any time to audit all of the related documentation. The Contractor shall make all documentation available for examination at the Auditor's request at either the Auditor's or Contractor's offices, and without expense to the City.

25. COMPLIANCE WITH IMMIGRATION REFORM AND CONTROL ACT OF 1986

Contractor certifies that Contractor has complied with the United States Immigration Reform and Control Act of 1986. All persons employed by Contractor for performance of this Contract have completed and signed Form I-9 verifying their identities and authorization for employment.

26. LABOR

The Contractor shall employ only competent and skilled workmen and foremen in the conduct of work on this Contract. The Contractor shall at all times enforce strict discipline and good order among Contractor's employees. The Project Manager shall have the authority to order the removal from the work of any person, including Contractor's or any subcontractor's employees, who refuses or neglects to observe any of the provisions of these Plans or Specifications, or who is incompetent, abusive, threatening, or disorderly in conduct and any such person shall not again be employed on the Project.

In accord with the Keep Jobs in Colorado Act, codified at sections 8-17-101, et seq., C.R.S., Colorado labor shall be employed to perform the work to the extent of not less than eighty percent (80%) of each type or class of labor in the several classifications of skilled and common labor employed on this Project et seq.; provided however, that this paragraph shall not apply if the Project receives federal funding.

In no event shall the City be responsible for overtime pay.

27. GRATUITIES

- A. This Contract may be terminated if the Mayor, the Mayor's designee, and/or the Procurement Services Manager determine, in their sole discretion, that the Contractor or any officer, employee, agent, or other representative whatsoever, of the Contractor offered or gave a gift or hospitality to a City officer, employee, agent or Contractor for the purpose of influencing



any decision to grant a City contract or to obtain favorable treatment under any City contract.

- B. The terms "hospitality" and "gift" include, but are not limited to, any payment, subscription, advance, forbearance, acceptance, rendering or deposit of money, services, or anything of value given or offered, including but not limited to food, lodging, transportation, recreation or entertainment, token or award.
- C. Contract termination under this provision shall constitute a breach of contract by the Contractor, and the Contractor shall be liable to the City for all costs of reletting the contract or completion of the project. Further, if the Contractor is terminated under this provision, or violates this provision but is not terminated, the Contractor shall be subject to debarment under the City's Procurement Regulations. The rights and remedies of the City provided in this clause shall not be exclusive and are in addition to any other rights and remedies provided by law or under this Contract.

28. NON-DISCRIMINATION

- A. In accord with section 24-34-402, C.R.S., Title VII of the Civil Rights Act of 1964, Americans with Disabilities Act of 1990 as amended, all applicable federal and state laws, the Contractor will not discriminate against any employee or applicant for employment because of disability, race, creed, color, sex, sexual orientation, gender identity, gender expression, religion, age, national origin, or ancestry.
- B. The Contractor agrees to post in conspicuous places, available to employees and applicants for employment, notices to be provided setting forth the provisions of this nondiscrimination clause.
- C. The Contractor will, in all solicitations or advertisements for employees placed by or on behalf of the Contractor, state that all qualified applicants will receive consideration for employment without regard to disability, race, creed, color, sex, sexual orientation, gender identity, gender expression, religion, age, national origin, or ancestry.

29. ORDER OF PRECEDENCE

Any inconsistency in this Contract shall be resolved by giving precedence in the following order:

- A. This Contract document with its terms and conditions
- B. Specific Construction Terms and Conditions
- C. General Construction Terms and Conditions
- D. The Statement of Work
- E. Specific Specifications
- F. General Specifications
- G. Other Appendices, Attachments, Exhibits, or Schedules

30. HEADINGS

The section headings contained in this Contract are for reference purposes only and shall not affect the meaning or interpretation of this Contract.



31. DISPUTES

- A. All administrative and contractual disputes arising from or related to this Contract other than those arising under Unanticipated Circumstances provisions (in section 107.27 of Schedule B General Construction Terms and Conditions) shall be addressed in the following manner:
1. If either Party disputes or disagrees with a Contract term or the other Party's interpretation of a Contract term or has any other administrative or contractual dispute not addressed in the Unanticipated Circumstances provisions, such Party shall promptly give the other Party written notice of said dispute.
 2. The Parties shall hold a meeting as soon as reasonably possible, but in no event later than thirty (30) calendar days from the initial written notice of the dispute, attended by persons with decision-making authority regarding the dispute, to attempt in good faith to negotiate a resolution of the dispute; provided, however, that no such meeting shall be deemed to vitiate or reduce the obligations and liabilities of the Parties or be deemed a waiver by a Party of any remedies to which such Party would otherwise be entitled unless otherwise agreed to by the Parties in writing.
 3. If, within thirty (30) calendar days after such meeting, the Parties have not succeeded in negotiating a resolution of the dispute, they agree to submit the dispute to non-binding mediation and to bear equally the costs of the mediation.
 4. The Parties will jointly appoint a mutually acceptable mediator. If they fail to do so within twenty (20) calendar days from the conclusion of the negotiation period, they shall each select a mediator. The two mediators will then appoint a third mediator who shall conduct mediation for the Parties as the sole mediator.
 5. The Parties agree to participate in good faith in the mediation and negotiations for a period of thirty (30) calendar days. The substantive and procedural law of the State of Colorado shall apply to the proceedings. If the Parties are not successful in resolving the dispute through mediation, then the Parties shall be free to pursue any other remedy afforded by the laws of the State of Colorado.
 6. Until final resolution of any dispute hereunder, the Contractor shall diligently proceed with the performance of this Contract as directed by the City. For purposes of this Contract, termination for convenience shall not be deemed a dispute. The City of Colorado Springs and the Contractor agree to notify each other in a timely manner of any claim, dispute, or cause of action arising from or related to this Contract, and to negotiate in good faith to resolve any such claim, dispute, or cause of action. To the extent that such negotiations fail, the City of Colorado Springs and the Contractor agree that any lawsuit or cause of action that arises from or is related to this Contract shall be filed with and litigated only by the Colorado District Court for El Paso County, CO.

32. DELIVERY

The City may cancel this Contract or any portion thereof if delivery is not made when and as specified, time being of the essence in this Contract. Contractor shall pay the City for any loss or damage sustained by the City because of failure to perform in accordance with this Contract.

33. PAYMENTS

All invoices shall be sent to the Project Manager identified in this Contract.



The City will pay the Contractor, upon submission of proper invoices, the prices stipulated in the Contract for services rendered and accepted, less any deductions provided in this Contract within 30 days (Net 30). The City will not pay late fees or interest. Any discount payment terms offered on the invoice may be taken by the City.

All payments for Construction will be made in accordance with the Payment provisions found in Schedule B – General Construction Terms and Conditions.

Each invoice must contain at least the following information:

Contract number, issued purchase order number, invoice number, invoice date, timeframe covered by invoice, type and amount of labor and materials used for that time period, dollar amount in unit price, extended price, and total value of invoice.

34. INSPECTION OF SERVICES

The Contractor is responsible for performing or having performed all inspections and tests necessary to substantiate that the services furnished under this Contract conform to Contract requirements, including any applicable technical requirements for specified manufacturers' parts. This clause takes precedence over any City inspection and testing required in the Contract's specifications, except for specialized inspections or tests specified to be performed solely by the City.

- A. Definition of "services", as used in this clause, includes services performed, workmanship, and material furnished or utilized in the performance of services.
- B. The Contractor shall provide and maintain an inspection system acceptable to the City covering the services under this Contract. Complete records of all inspection work performed by the Contractor shall be maintained and made available to the City during Contract performance and for as long afterwards as the Contract requires.
- C. The City has the right to inspect and test all services called for by the Contract, to the extent practicable at all times and places during the term of the Contract. The City will perform inspections and tests in a manner that will not unduly delay the work.
- D. If the City performs inspections or test on the premises of the Contractor or a subcontractor, the Contractor shall furnish, and shall require subcontractors to furnish, at no increase in Contract price, all reasonable facilities and assistance for the safe and convenient performance of these duties.

35. SECURITY

The City maintains security requirements regarding access to City buildings and other City workplaces and worksites on City property. All Contractor personnel accessing City buildings, workplaces, or worksites, may be required to produce a valid, Government issued picture identification. Contractor personnel lacking such identification may not be allowed access to such sites. No costs incurred by the Contractor due to City security requirements shall be allowable or payable under this Contract.



36. TIME IS OF THE ESSENCE

In as much as the Contract concerns a needed or required service, the terms, conditions, and provisions of the Contract relating to the time of performance and completion of work are of the essence of this Contract. The Contractor shall begin work on the day specified and shall prosecute the work diligently so as to assure completion of the work within the number of calendar days or date specified, or the date to which the time for completion may have been extended.

37. EMPLOYMENT OF LABOR

The Contractor shall comply with, and defend and hold the City harmless from any violation of all laws and lawful rules and regulations, both of the State of Colorado and of the United States, relating to Workmen's Compensation, unemployment compensation, Social Security, payment for overtime, and all other expenses and conditions of employment under this Contract.

38. SALES TAX

The Contractor must have a tax-exemption certificate from the Colorado Department of Revenue for this project. The certificate does not apply to City of Colorado Springs Sales and Use Tax which shall be applicable. The tax exempt project number and the exemption certificate only applies to County, PPRTA (Pikes Peak Rural Transportation Authority), and State taxes when purchasing construction and building materials **to be incorporated into this project**.

Furthermore, the exemption **does not** include or apply to the purchase or rental of equipment, supplies or materials that **do not become a part of the completed project or structure**. Such purchases and rentals are subject to full applicable taxation.

All contracts with subcontractors must include the City of Colorado Springs Sales and Use Tax on the work covered by the Contract, and other taxes as applicable.

Note: For all equipment, materials and supplies incorporated into the work purchased from vendors or suppliers not licensed to collect City Sales Tax (i.e. out of state suppliers, etc.), City Use Tax is due and payable to the City. The Contractor shall execute and deliver and shall cause the Contractor's subcontractors to execute and deliver to the City Sales Tax Office, the appropriate ST forms as designated by the City Sales Tax Office. These forms shall list all said equipment, materials and supplies and the corresponding use tax due, along with payment for said taxes. Any outstanding taxes due may be withheld from the final payment due the Contractor and may result in suspension of Contractor from bidding on City projects.

Forms and instructions can be downloaded at <https://coloradosprings.gov/sales-tax>. Questions can be directed to the City Sales Tax Division at (719) 385-5903.

Our Registration Numbers are as follows:
City of Colorado Springs
Federal I.D.: 84-6000573
Federal Excise: A-138557
State Sales Tax: 98-03479



The Contractor's payment or exemption of State of Colorado, El Paso County and City Sales and Use Taxes shall be as specified herein.

39. SEVERABILITY

If any terms, conditions, or provisions of this Contract shall be held unconstitutional, illegal, or void, such finding shall not affect any other terms, conditions, or provisions of this Contract.

40. LIABILITY OF CITY EMPLOYEES

All authorized representatives of the City are acting solely as agents and representatives of the City when carrying out and exercising the power or authority granted to them under the Contract. There shall not be any liability on them either personally or as employees of the City.

41. USE OF CITY NAME OR LOGO

Except as otherwise provided in this Contract, the Contractor shall not refer to this Contract or the City of Colorado Springs in any advertising or promotions in such a manner as to state or imply that the product or service provided is endorsed or preferred by the City of Colorado Springs, its employees, or its Departments, or is considered by these entities to be superior to other products or services. Any use of the name or logo of the City of Colorado Springs in advertising or promotions must be approved in writing by the City of Colorado Springs Contracts Specialist assigned to the Contract prior to such use.

42. TRAVEL

If travel expenses are included as a line item in this Contract, all travel expenses incurred and billable by the Contractor are subject to City approval. Air travel shall be limited to the round trip "economy coach" fare. Travel from the Colorado Springs Airport is encouraged. Unless there are extenuating circumstances, the Contractor should take advantage of lower airfares by purchasing tickets more than 14 days in advance of travel. In-state travel by air must be more economical than travel by private vehicle. Use of a private vehicle may be reimbursed per mile at the current rate published by the IRS annually. Short-term parking, long-term parking or cab fare associated with airport departure and arrival may be allowable expenses. Valet parking will not be allowed unless it is the least expensive or only option. Car rental rates may be reimbursed for car rentals no greater than the intermediate or standard classification. The City will not reimburse any other travel methods or expenses. The City will pay for lodging, meals, and miscellaneous expenses on a per diem basis only, in accordance with the current per diem rates published by the IRS annually. The City will not pay for Contractor expenses exceeding the per diem rates. Receipts for all reimbursable expenses must be provided with the Contractor's invoice.

43. ELECTRONIC SIGNATURE

This Agreement and all other documents contemplated hereunder may be executed using electronic signature with delivery via facsimile transmission, by scanning and transmission of electronic files in Portable Document Format (PDF) or other readily available file format, or by copy transmitted via email, or by other electronic means and in one or more counterparts, each of which shall be (i) an original, and all of which taken together shall constitute one and the same



agreement, (ii) a valid and binding agreement and fully admissible under state and federal rules of evidence, and (iii) enforceable in accordance with its terms

44. APPENDICES

The following Appendices are made a part of this Agreement:

1. Schedule A – Price Sheet
2. Schedule B – General Construction Terms and Conditions
3. Schedule C – Special Contract Terms and Conditions
4. Schedule D – General Specifications
5. Schedule E – Special and Technical Specifications
6. Schedule F – Scope of Work
7. Exhibit 1 – Performance, Labor and Material Payment, and Maintenance Bonds
8. Exhibit 2 – Minimum Insurance Requirements



CONTRACT SIGNATURE PAGE

IN WITNESS WHEREOF, the parties have caused these presents to be executed on the day and the year first above written.

This Contract is executed in one (1) original copy.

THE CITY OF COLORADO SPRINGS, COLORADO:

SECOND PARTY:	
Corporate Name	
Signature	Date
Title	



EXHIBIT 3 – EVALUATION SCORESHEET

RFP EVALUATION CRITERIA DESCRIPTION	SCORE
<p>1. TECHNICAL AREA</p> <p>The Offeror must explain its overall solution, considering the scope of work or statement of work provided. The content must include, but not necessarily be limited to, the following information.</p>	
<p>A. Understanding of and compliance with technical requirements</p>	
<p>In the Technical Area, the Offeror should address each work area in sufficient detail to demonstrate a clear and full understanding of the work. The proposal should not merely parrot the requirements of the RFP. Further, the Offeror should provide evidence of sufficient planning to ensure the work is completed on schedule and within budget.</p> <p>Consider the following questions.</p> <ol style="list-style-type: none"> 1. Does the proposal demonstrate a firm understanding of the requirements and goals of the Statement of Work, as well as industry standards and reasonable expectations for a company in the industry? 2. Does the proposal fully and completely address each requirement and goal of the Statement of Work? 3. Does the proposal provide solutions to indicate that requirements and goals will be met on schedule? 4. Does the technical solution seem realistic? 5. Does it generally appear that the Offeror knows and thoroughly understands the business and requirement? <p>COMMENTS:</p>	<p>5 – Exceptional 4 – Very Good 3 – Satisfactory 2 – Marginal 1 – Unacceptable</p> <p>Rating: _____</p>
<p>B. Project Approach</p>	
<p>In the Technical Area, the Offeror should clearly present proposed solutions and indicate that it has performed adequate planning to accomplish tasks as defined in the Statement of Work. Innovations, efficiencies, and detailed specifics are all encouraged.</p> <p>The Offeror must at least address the following areas:</p> <ol style="list-style-type: none"> 1. Construction phasing and traffic control for the project. Explain the phases, traffic control for each phase, and the logic in the construction phasing. 2. Erosion and sediment control during all phases of construction as well as post construction efforts through permit closure. 	<p>5 – Exceptional 4 – Very Good 3 – Satisfactory 2 – Marginal 1 – Unacceptable</p> <p>Rating: _____</p>



<p>3. Coordination with utilities. Discuss your understanding of the key utility relocations required for this project and how you will coordinate and phase your construction to both facilitate and accommodate those relocations and the constraints that they impose.</p> <p>4. Schedule Management. Discuss your approach to schedule management including updating and reporting progress of the work.</p> <p>5. Quality Control. Discuss your quality control plan, processes and approach to ensure that the City receives a quality product.</p> <p>6. Safety. Discuss the contractor's approach and commitment to safety for both construction workers and the public traveling through the construction site.</p> <p>7. Potential issues that your firm foresees with this project and how you would make adjustments if encountered. Describe factors limiting construction phasing flexibility and potential remedies.</p> <p>Consider the following questions.</p> <ol style="list-style-type: none"> 1. Does the proposal include a complete plan to accomplish each requirement, including subcontracting (if applicable)? 2. Does the proposal demonstrate that appropriate and qualified personnel and equipment will be provided to carry out the requirement? 3. Is the proper level of effort directed toward each requirement? Does the level of effort look unrealistically low or unreasonably high? <p>COMMENTS:</p>	
Sum of Ratings in Technical Area (Add numbers in Section 1.A. and 1.B):	
Evaluation Factor:	.20
Technical Area Evaluation Score (Multiply the sum of ratings in Technical Area by the evaluation factor):	
<p>2. MANAGEMENT AREA</p> <p>The Offeror must explain its method of managing the work to be performed. The content must include, but no necessarily be limited to, the following information.</p>	
<p>A. Program Management Controls</p>	
In the Management Area, the Offeror should provide a plan of operation, to include management of personnel, workload, schedule, and budget. It should also include	5 – Exceptional 4 – Very Good



<p>an organization chart which demonstrates clear and effective lines of authority, responsibility, and communication for management, supervisory, and technical personnel. The plan should address which job classification or personnel will be assigned to each task and how that determination is made. Basic human resource management concepts should be addressed, including hiring, firing, discipline, incentive plans, etc. If the Offeror plans to subcontract more than 10% of the work, include information on how the Offeror plans to manage its subcontractors.</p> <p>The Offeror shall provide a detailed construction schedule for the project showing the key construction activities and how they will meet or better the County's timeframe and maximize construction efficiency to provide the best value to the City and minimize impacts to the public. The schedule shall be based on the Offeror's understanding and approach to the work as addressed above.</p> <p>Consider the following questions.</p> <ol style="list-style-type: none"> 1. Does the proposal address the issues above in sufficient detail to demonstrate a sophisticated and mature management control system? 2. Are program management controls consistent with the technical portion of the proposal, especially regarding schedule and level of effort? 3. Does the plan and controls indicate that the Offeror will obtain, keep, and efficiently utilize high quality personnel? 4. Does the offer address corrective actions? 5. Does the proposal explain how the Offeror will remain within schedule and budget? <p>COMMENTS:</p>	<p>3 – Satisfactory 2 – Marginal 1 – Unacceptable</p> <p>Rating: _____</p>
<p>B. Past Performance/Relevant Experience and Key Personnel</p>	
<p>In the Management Area, the Offeror should provide at least three references or contracts demonstrating that it successfully provided services/products same or similar to those required in the RFP. The proposal should adequately explain how the projects were completed on schedule and within budget.</p> <p>Consider the following questions.</p> <ol style="list-style-type: none"> 1. Does the proposal include at least three references or past performance citations? 2. Are the references or past performance citations relevant to the requirements of the Statement of Work of the RFP? 3. Does the Offeror explain how they were successful on the projects provided as past performance? 4. Does the Offeror apply the past performance to the City requirement in such a way as to demonstrate added value due to experience? 	<p>5 – Exceptional 4 – Very Good 3 – Satisfactory 2 – Marginal 1 – Unacceptable</p> <p>Rating: _____</p>



<p>In the Management Area, resumes must be provided for all personnel considered key, as required by the RFP. It is highly recommended that the Offeror provide sufficient content and detail to answer completely the following questions. Resumes do not count toward the page limitation. Explain how the key personnel were related to the projects cited as relevant past performance.</p> <p>Consider the following questions.</p> <ol style="list-style-type: none"> 1. Does the Offeror provide complete resumes, including education, experience, background information, accomplishments, and other pertinent information? 2. Does the Offeror provide resumes for all key personnel, as required by the RFP? 3. Do the resumes demonstrate adequate professional, technical, and management levels to accomplish the work effectively and efficiently? <p>COMMENTS:</p>	
<p>Sum of Ratings in Management Area (Add numbers in Sections 2.A. and 2. B.)</p>	
<p>Evaluation Factor:</p>	.15
<p>Management Area Evaluation Score (Multiply the sum of ratings in Management Area by the evaluation factor):</p>	
3. PRICE/COST AREA	
<p>In the Price Area, the Offeror should provide a detailed breakdown of the price for each year of performance. The price must be fully loaded/all-inclusive and include unit cost for material, labor, other direct costs (e.g. travel), indirect costs (i.e. overhead and general and administrative costs), and profit/fee. Offers must include sufficient detail to allow insight into the fairness and reasonableness of the price. If the contract type will be T&M, labor categories, labor rates, separated profit, and estimated material costs must be included in detail.</p> <p>In addition, although price may not be the most important factor, it is still very important to the City of Colorado Springs. The Offeror's pricing must be competitive as compared to the budget amount, market pricing in the industry, and the pricing of the other Offerors.</p> <p>Consider the following questions:</p> <ol style="list-style-type: none"> 1. How does the price compare to the industry competition? 2. If low, is it unrealistically low? 3. If high, is there demonstrated added value for the additional cost? 	<p>5 – Exceptional 4 – Very Good 3 – Satisfactory 2 – Marginal 1 – Unacceptable</p> <p>Rating: _____</p>



COMMENTS:	
Total Price/Cost Area (Insert number from Section 3 evaluation above):	
Evaluation Factor:	.60
Price/Cost Area Evaluation Score (Multiply the Total Price/Cost Area by the evaluation factor):	
4. PROPOSAL PRESENTATION	
<p>Presentation is an important factor. Offerors should provide a highly professional product, which is complete, accurate, easily understood, and effectively presented.</p> <p>COMMENTS:</p>	<p>5 – Exceptional 4 – Very Good 3 – Satisfactory 2 – Marginal 1 – Unacceptable</p> <p>Rating: ____</p>
Total Proposal Presentation Area (Insert number from Section 4 evaluation above):	
Evaluation Factor:	.05
Proposal Presentation Area Evaluation Score (Multiply the Total Proposal Presentation Area score by the evaluation factor):	
EXCEPTIONS PROPOSED	
<p>What (if any) exceptions (redlines to our terms and conditions) were proposed? Are they acceptable?</p> <p>COMMENTS:</p>	Pass/Fail
TOTAL SCORE – Add Evaluation Scores from Sections 1-4 and location bonus (if applicable). The sum is the total score.	Total Score:



EXHIBIT 4 – SAMPLE BONDS

CITY OF COLORADO SPRINGS PERFORMANCE BOND

1. KNOW BY ALL MEN BY THESE PRESENTS, THAT

(Name)

(Address)

As Principal, hereinafter called “Principal,” and

(SURETY Name)

(SURETY Address)

A corporation organized and existing under the laws of the State of _____

And AUTHORIZED TO DO BUSINESS IN THE STATE OF COLORADO, as Surety, hereinafter called “Surety,” are held firmly bound to the CITY OF COLORADO SPRINGS, COLORADO as Obligee, hereinafter called “Obligee,” in the sum of WRITTEN DOLLAR AMOUNT (\$x, xxx, xxx. xx Dollars) lawful money of the United States of America, for payment of which sum well and truly to be made, the Principal and the Surety bind themselves, their heirs, executors, successors, and assigns, jointly and severally, firmly by these presents:

2. WHEREAS, the Principal and the Obligee have entered into a contract dated the XX day of XX, 2024 for the following project: Project Name Contract # C0XXXX, which contract is by reference made a part hereof, and referred to as “Contract.”
3. NOW THEREFORE, THE CONDITION OF THIS OBLIGATION IS SUCH THAT if the Principal shall promptly and faithfully perform all terms, conditions, and other obligations of the Contract, and any modifications or extensions thereof granted by the Obligee, then this obligation shall be null and void: otherwise, this obligation shall remain in full force and effect.
4. The Surety for value received agrees that no extension of time, change in, addition to, or other alteration or modification of the terms, conditions, or obligations of the Contract or work to be performed thereunder, or any forbearance on the part of either the Obligee or the Principal to the other shall in any way release or affect the liability or obligation of this Bond, and the Surety hereby waives notice of any such extension of time, change, addition, modification, alteration or forbearance.



Page Two (2) of Performance Bond

Signed and Sealed on the dates set forth below:

	FOR:	_____
_____ (Witness)		(PRINCIPAL'S Name)
	BY:	_____
	ITS:	_____
_____ (Seal)	This	_____ Day of _____, 2024
	FOR:	_____
_____ (Witness)	FOR:	(SURETY'S Name)
	BY:	_____
	ITS:	_____
_____ (Seal)	This	_____ Day of _____, 2024
Bond #:	_____ This Bond <input type="checkbox"/> (is) <input type="checkbox"/> (is not) an SBA Guaranteed Bond.	



CITY OF COLORADO SPRINGS LABOR & MATERIAL PAYMENT BOND

1. KNOW BY ALL MEN BY THESE PRESENTS, THAT

(Name)

(Address)

As Principal, hereinafter called "Principal," and

(SURETY Name)

(SURETY Address)

A corporation organized and existing under the laws of the State of _____

And AUTHORIZED TO DO BUSINESS IN THE STATE OF COLORADO, as Surety, hereinafter called "Surety," are held firmly bound to the CITY OF COLORADO SPRINGS, COLORADO as Obligee, hereinafter called "Obligee," in the sum of WRITTEN DOLLAR AMOUNT (\$x, xxx, xxx. xx Dollars) lawful money of the United States of America for payment of which sum well and truly to be made, the Principal and the Surety bind themselves, their heirs, executors, successors, and assigns, jointly and severally, firmly by these presents:

2. WHEREAS, the Principal and the Obligee have entered into a contract dated the XX day of XX, 2024 for the following project: Project Name Contract # C0XXXX, which contract is by reference made a part hereof, and referred to as "Contract."

3. NOW THEREFORE, THE CONDITION OF THIS OBLIGATION IS SUCH THAT, if the Principal shall promptly make payments of all amounts lawfully due to all persons supplying or furnishing the Principal or the Principals subcontractors with labor, materials, rental machinery, tools, or equipment used or performed in the prosecution of the work provided for in the Contract; and if the Principal shall indemnify and save harmless the Obligee to the extent of any payments in connection with the carrying out of the Contract which the Obligee may be required to pay under the law, all in accord with Colorado State Law, Section 38-26-105 C.R.S., then this obligation shall be null and void; otherwise this obligation shall remain in full force and effect.

AND FURTHER, should the Principal or the Principal's subcontractors fail to duly pay for any labor, materials, team hire, sustenance, provisions, provender, or other supplies used or consumed by the Principal or the Principal's subcontractors in the performance of the work contracted to be done, or fails to pay any person who supplies rental machinery, tools or equipment, all amounts due as the result of the use of such machinery, tools, or equipment, in the prosecution of the work under the Contract, the Surety shall pay the same in an amount



not exceeding the sum specified in this Bond together with interest at the rate of eight percent per annum, in accordance with Colorado State Law, Section 38-26-106 C.R.S.

In accordance with Colorado State Law, Section 38-26-105 C.R.S., actions against the Principal and Surety under this Bond shall be brought within six months after the final completion of the Contract as defined by the ordinances, rules, and regulations of the City of Colorado Springs, Colorado, a home rule City, and not afterwards.

4. The Surety for value received agrees that no extension of time, change in, addition to, or other alteration or modification of the terms, conditions, or obligations of the Contract or work to be performed thereunder, or any forbearance on the part of either the Obligee or the Principal to the other shall in any way release or affect the liability or obligation of this Bond, and the Surety hereby waives notice of any such extension of time, change, addition, modification, alteration or forbearance.



Page Two (2) of Labor and Material Payment Bond

Signed and Sealed on the dates set forth below:

	FOR:	_____
_____ (Witness)		(PRINCIPAL'S Name)
	BY:	_____
	ITS:	_____
_____ (Seal)	This	_____ Day of _____, 2024
	FOR:	_____
_____ (Witness)	FOR:	(SURETY'S Name)
	BY:	_____
	ITS:	_____
_____ (Seal)	This	_____ Day of _____, 2024
Bond #:	_____	This Bond <input type="checkbox"/> (is) <input type="checkbox"/> (is not) an SBA Guaranteed Bond.



CITY OF COLORADO SPRINGS MAINTENANCE BOND

1. KNOW BY ALL MEN BY THESE PRESENTS, THAT

(Name)

(Address)

As Principal, hereinafter called "Principal," and

(SURETY Name)

(SURETY Address)

A corporation organized and existing under the laws of the State of _____

And AUTHORIZED TO DO BUSINESS IN THE STATE OF COLORADO, as Surety, hereinafter called "Surety," are held firmly bound to the CITY OF COLORADO SPRINGS, COLORADO as Obligee, hereinafter called "Obligee," in the sum of WRITTEN DOLLAR AMOUNT (\$x, xxx, xxx. xx Dollars) lawful money of the United States of America for payment of which sum well and truly to be made, the Principal and the Surety bind themselves, their heirs, executors, successors, and assigns, jointly and severally, firmly by these presents:

2. WHEREAS, the Principal and the Obligee have entered into a contract dated the XX day of XX, 2024 for the following project: Project Name Contract # C0XXXX, which contract is by reference made a part hereof, and referred to as "Contract."
3. NOW THEREFORE, THE CONDITION OF THIS OBLIGATION IS SUCH THAT, if the Principal shall promptly, properly, and without cost to Obligee perform all maintenance and other guarantee obligations under the terms of the Contract, including any modifications or extensions thereof granted by the Obligee, for a period of TWO (2) year(s) from the date of final payment upon the Contract by the Obligee, and in the case of each correction or repair, during a period of ONE (1) year after the date of said correction or repair or for the remaining period of years set forth herein, whichever is longer, then this obligation shall be null and void; otherwise this obligation shall remain in full force and effect.
4. The Surety for value received agrees that no extension of time, change in, addition to, or other alteration or modification of the terms, conditions, or obligations of the Contract or work to be performed thereunder, or any forbearance on the part of either the Obligee or the Principal to the other shall in any way release or affect the liability or obligation of this Bond, and the Surety hereby waives notice of any such extension of time, change, addition, modification, alteration or forbearance.



Page Two (2) of Maintenance Bond

Signed and Sealed on the dates set forth below:

	FOR:	_____
_____		(PRINCIPAL'S Name)
(Witness)		
	BY:	_____
	ITS:	_____
_____	This	_____ Day of _____, 2024
(Seal)		
	FOR:	_____
_____	FOR:	(SURETY'S Name)
(Witness)		
	BY:	_____
	ITS:	_____
_____	This	_____ Day of _____, 2024
(Seal)		
Bond #:	_____ This Bond <input type="checkbox"/> (is) <input type="checkbox"/> (is not) an SBA Guaranteed Bond.	



ORIGINAL COPY
POWER OF ATTORNEY ON ALL BONDS



SCHEDULES

Schedule A	Bid Tab
Schedule B	General Construction Terms and Conditions
Schedule C	Scope of Work
Schedule D	City Stormwater Management Plan (CSWMP)
Schedule E	Project Specific Special Provisions
Schedule F	Project Special Technical Specifications
Schedule G	Drawings
Schedule H	GEC Drawings



SCHEDULE A – BID TAB

Will follow this page. Submit Schedule A – Bid Tab in Excel Format

ITEM	DESCRIPTION OF BID ITEM	QUANTITY	PAY	UNIT PRICE	BID ITEM
Capital Improvement Costs					
1	Mobilization	1	LS		\$ -
2	Traffic Control	1	LS		\$ -
3	Water Control and Dewatering	1	LS		\$ -
4	Clearing and Grubbing	22.1	AC		\$ -
5	Erosion Control	1	LS		\$ -
6	Removal of Structures and Obstructions	1	LS		\$ -
7	Cut Soil Cement	6,300	SF		\$ -
8	Remove Concrete Structure	1	LS		\$ -
9	Topsoil, Excavation and Stockpile	28,771	CY		\$ -
10	Topsoil, Replace	16,207	CY		\$ -
11	Earthwork, Excavation	28,522	CY		\$ -
12	Earthwork, Fill With Onsite Material	28,522	CY		\$ -
13	Earthwork, Fill with Stockpiled Material	16,647	CY		\$ -
14	Upland Seed and Mulch	470,000	SF		\$ -
15	Wetland/Riparian Seed and Mulch	345,000	SF		\$ -
16	Wetland Plugs (10 cu in plug)	60,564	EA		\$ -
17	Cottonwood Poles (harvest and install)	6	EA		\$ -
18	Deciduous Trees (2" cal. B&B)	31	EA		\$ -
19	Deciduous Shrubs (#5 container)	703	EA		\$ -
20	Void-Permeated Type L Riprap	897	CY		\$ -
21	Harvest, Restore, and Replace Void-Permeated Type M Riprap	41	CY		\$ -
22	Void-Permeated Type M Riprap	1,321	CY		\$ -
23	Harvest, Amend, and Replace Type H Void-Permeated Riprap	102	CY		\$ -
24	Void-Permeated Type H Riprap	249	CY		\$ -
25	Harvest, Restore, and Replace Soil Type L Riprap	544	CY		\$ -
26	Soil Type L Riprap	1,573	CY		\$ -
27	Grouted Boulders	687	CY		\$ -
28	Structural Concrete	306	CY		\$ -
29	Structural Concrete With Integral Color	440	CY		\$ -
30	Backfill Concrete	356	CY		\$ -
31	Remove 18" RCP	100	LF		\$ -
32	Remove FES 18" Diameter	5	EA		\$ -
33	Sheet Pile	1,408	SF		\$ -
34	Sheet Pile Cap	176	LF		\$ -
35	Granite Sand Aggregate (Maintenance Access)	2,204	LF		\$ -
36	Remove Tree (>8")	1	EA		\$ -
37	Removable Stop Logs System	1	LS		\$ -
38	Structural Aesthetic Treatments	1	LS		\$ -
39	Railing	354	LF		\$ -
40	Water Feature Boulder	17	EA		\$ -
41	TrueGrid Pavers	2,005	SY		\$ -
42	Muck Excavation	7,200	CY		\$ -
43	Flood Warning Sign	3	EA		\$ -
44	Force Account	1	EA	\$150,000.00	\$ 150,000.00
Grand Total					\$ 150,000.00



SCHEDULE B – GENERAL CONSTRUCTION TERMS AND CONDITIONS

SECTION 100 DEFINITIONS AND TERMS

Titles used in these specifications having a masculine gender, such as “workmen” and the pronouns “he” or “his”, are for the sake of brevity and are intended to refer to persons of any gender.

The titles or headings of the sections and subsections herein are intended for convenience of reference and shall not have any bearing on their interpretation.

When the Contract indicates that something “shall” be done, the action is required and is not discretionary.

Calendar Day Each and every day shown on the calendar, beginning and ending at midnight.

Change Order A written order issued to the Contractor by the City covering contingencies, extra work, increases or decreases in Contract quantities, and additions or alterations to the plans or specifications, within the scope of the Contract, and establishing the basis of payment and time adjustments for the work affected by the changes. The Change Order is the only method authorized for changing the Contract.

City The City of Colorado Springs, Colorado.

Contract Documents Contract Documents include the Request for Proposal, Instructions to Offerors, Proposal, Amendments, the signed Contract, surety bonds, insurance documents, all terms, conditions, and provisions, and the Specifications, including all modifications thereof incorporated in any of the documents before execution of the agreement.

Contract The executed written agreement between the City and the Contractor setting forth the obligations of the parties for the performance of the work and the basis of payment. The Contract includes the Contract Documents, Notice to Proceed, and executed Change Orders, all of which constitute one instrument.

Contractor The person, persons, firm, or corporation to whom a Contract is awarded by the City and who is subject to the terms of said Contract. Contractor shall include the agents, employees, workmen, subcontractors and any assignees of said Contract.

Engineer An engineer of the City of Colorado Springs.



Notice	<p>Any written notice served pursuant to the terms of the Contract. Notice shall be deemed to have been duly served if delivered in person or by registered mail to:</p> <p>The Project Manager assigned to the Contract, City of Colorado Springs, City Engineering, 30 South Nevada Ave., Room 403, Colorado Springs, CO 80903.</p> <p>Notice to the Contractor will be to the Authorized Representative of the Contractor at the site of the Project in person; or by registered mail to the Contractor's principal place of business as indicated in the Contractor's proposal certifications; or as to the Surety on the performance bond by registered mail to the Surety at the home office of such surety.</p>
Plans	<p>The drawings, or reproductions, provided by the City that show the location, character, dimensions, and details of the work to be done.</p>
Project Manager	<p>An individual representing the City responsible for managing and oversight of the Contract. .</p>
Project	<p>The entire improvement outlined in the Scope of Services which is to be constructed in whole or in part pursuant to the Contract.</p>
Subcontractor	<p>A person, firm, or corporation, other than the Contractor, supplying labor or materials, or both, or equipment furnished at the site of the project under an Agreement with the Contractor.</p>
Surety	<p>The person, firm, or corporation that has executed as surety the Contractor's Proposal, Performance, Payment and Maintenance Bonds.</p>
Work	<p>Work performed under the Contract.</p>
Working Days	<p>Days of the week, not including weekends and City holidays, unless otherwise stated.</p>

SECTION 101 CONTRACT DOCUMENT INTERPRETATION

101.00 INTENT OF CONTRACT DOCUMENTS

The sections of the Contract Documents are complementary, and what is called for by any one shall be as binding as if called for by all. The intent of the Contract Documents is to include the cost of all labor and materials, water, fuel, tools, plants, equipment, light, transportation, and all other expenses as may be necessary for the proper execution of the work. If the Contract Documents should be contradictory in any part, the order of precedence shall be as described in the Contract.



Any work shown on the Plans and not covered in the specifications, or included in the Specifications and not shown on the Plans, shall be executed by the Contractor as though shown both on the Plans and included in the Specifications.

If the Contractor, in the course of the work, finds any discrepancy between the Plans and the physical layout, or any errors or omissions in Plans or layout, he shall immediately so inform the Project Manager and the Project Manager will promptly verify them. Any work done after such discovery without written consent of the Project Manager authorizing the same shall be done at the Contractor's risk and sole expense.

Any incidental and/or appurtenant items not specifically called for in the Plans and Specifications, but which are necessary to complete the work in accordance with the requirements of good practice, as determined by the Project Manager, shall be included as a part of the Contractor's proposal price and furnished at no additional cost to the City.

In interpreting the Contract Documents, words describing materials or work which have a well-known technical or trade meaning, unless otherwise specifically defined in the Contract documents, shall be construed in accordance with such well known meaning recognized by architects, engineers, and the trade.

101.01 SPECIAL PROVISIONS, SPECIAL SPECIFICATIONS

Special Provisions or Special Specifications may be written to expand upon, modify or cancel these general provisions or the standard specifications.

101.02 STANDARD MANUFACTURER

Wherever the terms "standard", "recognized" or "reputable" manufacturers are used, they shall be construed as meaning manufacturers who have been engaged in the business of fabricating materials, equipment, or supplies of the nature called for by the Specifications for a reasonable period of time prior to the date set for submission of proposals, and who can demonstrate to the satisfaction of the City that said manufacturer has successfully installed equipment, materials, or supplies of the type proposed to be furnished in at least three instances and that the performance of such materials, equipment, or supplies for a period of over twelve months prior to the date fixed for submission of proposals shall, prima facie, be deemed to have been engaged in such business for a reasonable length of time.

101.03 "OR EQUAL" CLAUSE

Whenever in any section of the Contract documents, any article, material, or equipment is defined by describing a proprietary product, or by using the name of manufacturer or vendor, the term "or equal" if not inserted, shall not be construed in such a manner as to exclude manufacturers' products of comparable quality, design, and efficiency, subject to review and approval by the Project Manager. The Project Manager may require that proposed equals be submitted for review and approval.

SECTION 102 COMPLIANCE WITH LAWS



102.00 PUBLIC IMPROVEMENT ASSESSMENT

If the cost of the improvement to be constructed under the Contract is to be assessed upon the owners of land benefited by such improvement, upon complaint of any such landowner that the improvement is not being constructed in accordance with the Contract, the City Council may consider the complaint and make such order in the premises as shall be just to ensure compliance with the Contract.

102.01 ALL LEGAL PROVISIONS INCLUDED

It is the intention and agreement of the parties to this Contract that all legal provisions of law required to be inserted, shall be and are inserted. However, if by mistake or otherwise, some such provision is not inserted, or is not inserted in proper form, then upon application of either party, the Contract shall be amended so as to strictly comply with the law and without prejudice to the rights of either party.

102.02 LICENSES AND PERMITS

It shall be the responsibility of the Contractor to obtain, at its expense, all necessary licenses and permits to do the Project, in accordance with applicable Federal, State and local laws, regulations and ordinances. Typical permits and fees include, but are not limited to, Excavation/Boring Permits, Concrete Construction Permits, Fugitive Dust Permits, Regional Building Permits, Pavement Degradation fees, as well as Traffic Control and Barricade Plans to be approved by the City Traffic Division for all work within public rights-of-way and easements i.e. (curb and gutter, sidewalks, pedestrian ramps and cross pans).

SECTION 103 AWARD AND EXECUTION OF CONTRACT

103.00 CONTRACT EXECUTED

A single original Contract to include the Contractor's Performance, Labor and Material Payment and Maintenance Bonds may be executed and maintained in the official Contract file located in the City Contracts office. The original copy of the Contract maintained in the City Procurement Services file shall take precedence for purposes of interpretation or determining what the Contract says. After all required signatures are obtained; photocopy counterparts (copies) will be made and distributed to the following, as applicable:

- (a) Contractor
- (b) Project Manager
- (c) City Finance Department
- (d) Inspector

Each Bond shall have an original Power of Attorney attached. The Contractor shall provide compensation insurance and public liability and property damage insurance as outlined in the Contract. The costs of executing the bonds, Contract, and insurance, including all notaries' fees and expense, are to be paid by the Contractor to whom the Contract is awarded. Bonds shall be furnished on forms prepared by the City. Copies of the City's Bond Forms are included in the Exhibits Section of the Request for Proposal, if applicable.



103.01 VERBAL AGREEMENTS

No verbal agreements or conversations with any agent or employee of the City either before or after execution of the Contract shall affect or modify any of the terms or obligations contained in any of the documents comprising the Contract.

103.02 CONTRACT SECURITY

The Contractor shall furnish good and sufficient Performance, Labor and Material Payment and Maintenance Bonds on the form attached hereto in an amount not less than the full amount of the Contract price as security for the faithful performance of the Contract, for the payment of all persons performing labor and furnishing material in connection with the work, and for all guarantees of materials and workmanship required in the Contract. If at any time during the continuance of the Contract a surety on the Contractor's bond or bonds becomes irresponsible, as determined in the City's sole and absolute discretion, the City shall have the right to require additional and sufficient sureties which the Contractor shall furnish within ten (10) days after written notice to do so. Any additional surety bonds shall cover the entire original Contract amount and any increases thereto.

103.03 INDEPENDENT CONTRACTOR

In the performance of the Contractor's obligations under this Contract, it is understood, acknowledged and agreed between the parties that the Contractor is at all times acting and performing as an Independent Contractor, and the City shall neither have nor exercise any control or direction over the manner and means by which the Contractor performs the Contractor's obligations under this Contract, except as otherwise stated within the Contract terms. The City shall not provide any direction to the Contractor on the work necessary to complete the Project. Contractor understands that it is an independent contractor responsible for knowing how to perform all work or tasks necessary to complete Project. The Contractor understands and agrees that the Contractor and the Contractor's employees, agents, servants, or other personnel are not City employees. The Contractor shall be solely responsible for payment of salaries, wages, payroll taxes, unemployment benefits or any other form of compensation or benefit to the Contractor or any of the Contractor's employees, agents, servants or other personnel performing services or work under this Contract, whether it be of a direct or indirect nature. Further in that regard, it is expressly understood and agreed that for such purposes neither the Contractor nor the Contractor's employees, agents, servants or other personnel shall be entitled to any City payroll, insurance, unemployment, worker's compensation, retirement or any other benefits whatsoever.

SECTION 104 THE CONTRACT: FOLLOWING EXECUTION

104.00 MATERIALS

Unless otherwise stipulated in the Contract, the Contractor shall provide and pay for all materials, labor, water, tools, equipment, light power, transportation, and other facilities necessary for the execution and completion of the work. The Contractor shall, if required, furnish satisfactory evidence as to the kind and quality of materials.

104.01 SCHEDULE



In the event of contradictions or inconsistencies, this clause shall take precedence over any language relevant to scheduling included anywhere else in this Contract.

The Contractor shall be responsible for planning, scheduling, and reporting the progress of the work to ensure timely completion of the work as called for in the Contract Documents. The Contractor shall prepare a detailed Project schedule (“Project Schedule”) that shall be used for coordination, for evaluation of progress, and for the evaluation of changes to the Contract. The Project Schedule shall include all activities, including those of subcontractors, Contractor’s engineers and surveyors, and suppliers. Seasonal and weather constraints, utility coordination, railroad restrictions, right of way restrictions, traffic constraints, environmental constraints, other project interfaces, expected job learning curves and other constraints shall be considered when preparing the Project Schedule, including any phasing or sequencing of the work specified in the Contract Documents. Days scheduled as no work days shall be indicated. The Project Schedule shall consist of a Methods Statement as defined in subsection (a) below and a progress schedule consisting of (1) a Critical Path Method (“CPM”) schedule as defined in subsection (b) below, or (2) a Bar Chart schedule as defined in subsection (c) below. A CPM Schedule shall be required if the Contract exceeds \$250,000 or if the construction period exceeds 150 Calendar Days, unless the Contract Documents stipulate otherwise. The CPM Schedule shall utilize Primavera’s Suretrak Project Manager software (or other software designated by the Project Manager), or be capable of being read and manipulated by Suretrak Project Manager software (or other software designated by the Project Manager). The Project Schedule shall show all work completed within the Contract Period of Performance. The City reserves the right to approve or disapprove any proposed schedule. If disapproved, the Contractor must make requested changes and resubmit the schedule for approval within five working days of the disapproval by the City.

After award, the Contractor shall submit two copies of all required schedule information as described below. Schedules, schedule updates, diagrams and reports using CPM shall also be submitted electronically in the appropriate software format. All schedules, diagrams, and reports shall include a title, project number, date of preparation, and the name of the Contractor.

The Bar Chart or CPM 90-day schedule shall be submitted at least 14 Calendar Days prior to the start of the work. The Project Manager’s review will not exceed five working days. Work shall not begin until the Project Schedule is accepted in writing, unless otherwise approved by the Project Manager.

(a) Methods Statement. A Methods Statement shall be prepared for the prominent features listed in the Contract Documents, and for any feature not listed in the Contract Documents that the Contractor considers a controlling factor for timely completion. The Methods Statement shall be a detailed narrative describing each feature and all work necessary to complete the feature. The Methods Statement shall be submitted with the Contractor’s schedule. The following format is required:

1. Feature: Name of the feature;
2. Responsibility: Contractor, subcontractor, supplier, utility, etc. responsible for the feature;
3. Procedures: Procedures to be used to complete the work. The procedure to be used shall include general information regarding methods such as forming, excavation, pouring, heating and curing, backfill and embankment, trenching, protecting the work, etc. When separate or different procedures are to be



employed by the Contractor due to seasonal or Project phasing requirements, such differing procedures shall be described in the procedure statement;

4. Production Rates: The planned quantity of work per day for each feature;
5. Labor Force: The labor force planned to do the work;
6. Equipment: The number, types, and capacities of equipment planned to do the work;
7. Work Times: The planned time for the work to include:
 - (a) number of work days per week
 - (b) number of shifts per day
 - (c) number of hours per shift

At the Project Manager's request, the Contractor shall update the Methods Statement, or any part thereof, and submit it with the Job Progress Narrative Report or Schedule Update, whichever is earlier.

- (b) Critical Path Method. CPM is a scheduling method which shows the interdependencies between work activities. The critical path is that path through the schedule which, if delayed, will cause a delay to project completion.

The progress schedule shall include as a minimum the prominent features of this Project as listed in the Contract Documents. The progress schedule shall include all activities for all work on the Project, including subcontracted work, delivery dates for critical material, submittal and review periods, milestone requirements and no work periods. Where the Project has specific phases, each phase shall be described separately for each applicable prominent feature.

Construction activity duration shall not exceed 15 Calendar Days unless approved by the Project Manager. Series of activities that have aggregate durations of five Calendar Days or less may be grouped in a single activity. For example, "form, reinforce, and pour pier" could be defined as a single activity rather than three. Single activities or a series of grouped activities of at least one Calendar Day duration may also need to be included in the Project Schedule as determined by the Project Manager (e.g. same activities but noted separately by location).

Time Scaled Logic Diagram: This diagram shall show the logical progression of all activities required to complete the work defined in the Contract Documents. Activity information shall include activity ID, description, duration, early start and finish dates, late start and finish dates, total float, and responsibility.

1. 90-Day Schedule. The 90-Day Schedule shall provide all necessary detail for procurement, construction and submittal activities required during the first 90 days of the Period of Performance. This submittal shall include a Time Scaled Logic Diagram.
2. Project Schedule, as described above.

The Project Schedule shall cover the entire Period of Performance.
3. Schedule Updates. The Contractor shall update the 90-Day Schedule or the Project Schedule to reflect actual construction progress of all work activities on the project. Updates shall show the previous 30 days progress and a 60-day



projection for all work started, completed, or in progress during this three month window.

The Project Schedule shall be updated as of the cutoff date for the monthly progress pay estimate and submitted to the Project Manager before the payment of the progress pay estimate is approved.

Each of the diagrams, charts, and reports shall comply with the requirements for the Project Schedule above, except that they shall also include the actual completion dates and percentages of completion for the appropriate activities.

(c) Bar Chart. The Bar Chart shall be time scaled and shall show the following:

1. The prominent features, as listed in the Contract Documents.
2. Any feature not listed in the Contract Documents that the Contractor considers a controlling factor for timely completion.
3. The number of days required to complete each feature and its relationship in time to other features.
4. Sufficient space for each feature to permit two additional plots parallel to the original time span plot.
5. The anticipated delivery dates for equipment or materials in any feature that could affect timely completion of the project.
6. Critical completion dates for any activity within any feature that could affect timely completion of the project.
7. Connecting lines between features that show the intended progression of activities.

The Project Schedule shall cover the time from the Day of Notice to Proceed to the predicted completion date. The Project Schedule shall be updated as of the cutoff date for the monthly progress pay estimate and submitted to the Project Manager before the payment of the progress pay estimate is approved. The Contractor shall provide a copy of the original bar chart showing, for each feature, the days actually worked and the anticipated days required to complete.

(d) Project Coordination. The Contractor shall coordinate and schedule its work to include anticipated utility work. Various City and private utility entities may be working to install and/or inspect their utilities within the Project area. Reasonable delays should be expected for utility lowering, relocations and placement. These delays shall not be reason for granting any monetary change or performance time alteration to the Contract. As a minimum, the Contractor's Project Schedule shall reflect coordination with the following:

1. City of Colorado Springs City Engineering Division
2. City of Colorado Springs Traffic Engineering Division
3. Colorado Springs Utilities (water, wastewater, gas, electric)
4. City of Colorado Springs Parks, Recreation and Cultural Services Department
5. Private Utility and Telecommunication Companies

(e) Contractor Early Finish or Voluntary Acceleration. Early finish or voluntary acceleration of the schedule by the Contractor is acceptable provided:



1. At the time the Contractor submits the Project Schedule indicating an early finish or voluntary acceleration, the City is notified in writing of actions on the City's part necessary to accommodate the change(s).
2. The City agrees to such change(s) in writing.
3. The City is compensated by the Contractor for any inconvenience or expense associated with the change(s).
4. There is no increase to Contract cost.

A Job Progress Narrative Report shall be submitted bi-weekly as a minimum and with all Project Schedule updates. It shall detail the description of job progress, problem areas, current and anticipated delaying factors and their anticipated effects, impacts to job milestones or Project completion, any corrective action proposed or taken, and any minor revisions to the Project Schedule. If the Job Progress Narrative Report indicates problem areas and impacts to job milestones or Project completion, a revised Project Schedule shall also be submitted as specified below.

Revision of the Project Schedule may be required, as determined by the Project Manager, for: a major revision in the schedule logic or methods of construction; the addition, deletion, or revision of activities required by Contract modification; delays in milestones or the completion of the Project; or for prosecution of work that revises the phasing or staging which is represented on the plans or on the progress schedule. If in the opinion of the Project Manager, the Contractor falls behind the approved Project Schedule, the Contractor shall take steps necessary to improve Project progress, including those steps that may be required by the Project Manager, without additional costs to the City. In those circumstances where the Contractor is behind schedule, the City may require the Contractor to increase the number of shifts, overtime operations, days of work, and/or the amount of construction planned and to submit such changes and revisions to the Project Schedule to the Project Manager for approval that will demonstrate how the approved rate of required progress will be regained. Failure of the Contractor to comply with the requirements of the Project Manager under this subsection shall be grounds for a determination by the City that the Contractor is not prosecuting the work with sufficient diligence to ensure timely completion of the Contract as required.

If it is determined that a revision to the Project Schedule is required, it shall be provided to the Project Manager for review within 15 Calendar Days of Contractor receiving written notification of the requirement from the Project Manager. The Project Manager's review of the revised schedule will not exceed 5 working days. Revisions required as a result of the Project Manager's review shall be submitted within 5 working days. When accepted by the Project Manager in writing, the revised schedule shall become the Project Schedule.

The Contractor shall participate in the Project Manager's review and evaluation of the submittals. Meetings will be held to review progress and planning when requested by the Project Manager or Contractor. The Project Manager may request additional project scheduling information and documentation as deemed necessary, including reports and other information that may be reasonably generated using CPM software if required by the Contract.

The Contractor shall prosecute the work according to the Project Schedule. The Contractor shall be responsible for assuring that its subcontractors, suppliers, and engineers/surveyors, at any tier, also prosecute the work according to the Project Schedule. The City shall be entitled to rely on the Project Schedule for planning and coordination.



Acceptance of the Contractor's Project Schedule by the Project Manager is not to be construed as relieving the Contractor of obligation to complete the Contract work within the Contract time allowed for the portion of the work or the entire Contract, or granting, rejecting or in any other way acting on the Contractor's request for extension of Contract time, or claims for additional compensation.

All costs relating to preparation, submittal, and acceptance of the Project Schedule, reports and revisions, and all requirements of this subsection will not be paid for separately, but shall be included in the work.

Failure of the Contractor to comply with the requirements of this subsection may be grounds for a determination by the Project Manager that no further progress payments are to be made until the Contractor is in full compliance.

104.02 SCHEDULE OF VALUES

Promptly following the execution of the Contract Documents for all Firm Fixed Price, lump sum Contracts, the Contractor shall prepare and transmit to the Project Manager two copies of an itemized Project cost breakdown showing the unit quantities of each major construction item and the corresponding unit prices. Such unit prices shall contain all costs including profit and overhead of each item complete in place. The total cost of all the items shall equal the Contract price for the Project. This breakdown, once approved by the Project Manager, will be used primarily in determining payment due the Contractor as provided herein. If, in the opinion of the Project Manager, any unit price submitted by the Contractor is unbalanced, a detailed breakdown of the items contained in the unit will be required.

For Contracts executed on a fixed unit price basis, payment shall be made based on the actual number of units installed or performed that are complete, however, payment shall not exceed the total Contract amount unless previously approved by Change Order.

104.03 SURVEYS

Unless otherwise specified in the Contract Documents, the City will furnish all site surveys, easements, pipeline licenses, etc., necessary to authorize construction of any permanent works required in the Contract, where such work is to be done on property other than the City's.

The Project limits of construction shall be within the public right-of-way and/or City easements. The Contractor shall not trespass on premises outside of the limits of construction for this Project, unless permission to do so is granted by the property owner in writing. Copies of any such grant shall be furnished to the City prior to the performance of any work outside the limits of construction.

104.04 SUBCONTRACTS

The Contractor will be permitted to subcontract a portion of the Contract; however, the Contractor shall perform work amounting to 30 percent or more of the original total cost of proposal items. Any items designated in the Contract as "specialty items" may be performed by subcontractor. The cost of "specialty items" so performed by subcontractor may be deducted from the original



total cost of proposal items before computing the amount of work required to be performed by the Contractor.

The calculation of the percentage of subcontracted work shall be based on the Contract unit prices rather than subcontract unit prices. Proportional value for a subcontracted partial Contract item will be verified by the Project Manager. For the purpose of calculating the value of subcontracted work, the cost of procuring materials and manufactured products can be included in either the Contract or subcontract. However, when a firm both sells material to a Contractor and performs the work of incorporating the materials into the Project, these two phases shall be considered in combination and as constituting a single subcontract.

The Contractor shall as soon as practical after signing the Contract notify the Project Manager in writing, giving the names and qualifications, of all subcontractors proposed to do work on the Project within fifteen (15) business days of notice of award. The City shall have the right to reject subcontractors who are debarred or suspended from doing business with the federal government, State government, or the City of Colorado Springs. The Contractor shall notify the Project Manager of each subcontract he awards, giving:

- (a) Name, address, and telephone number of the subcontractor
- (b) Branch of work covered
- (c) Total price of subcontract
- (d) Date of subcontract

It shall be the responsibility of the Contractor to file with the Project Manager copies of applicable permits and licenses required to do the subcontracted work. Subcontracts or transfer of Contract obligations shall not release the Contractor of liability under the Contract and bonds.

104.05 OTHER CONTRACTS

The City may undertake or award other Contracts for additional work at or near the site of the work under this Contract. The Contractor shall fully cooperate with the other Contractors and with City employees and shall carefully adapt their scheduling and performance of the work to accommodate the additional work, heeding any direction that may be directed by the Project Manager. The Contractor shall not commit or permit any act, which will interfere with the performance of work by any other contractor.

SECTION 105 CONSTRUCTION SITE

105.00 LANDS TO BE USED FOR WORK

The Contractor shall confine the work activities to the area shown in the construction drawings. The Project Manager will furnish the Contractor with copies of all executed right of way (ROW) and easement documents for the Project. The established work zone shall be marked and secured with orange safety fence. Any additional work area required within adjoining private properties must be acquired by the Contractor by written permission from the property owner. The Contractor shall restore any damage or disruption to other properties utilized in the performance of this Project to an equal or better than pre-construction condition at no cost to the City. The Contractor shall indemnify and hold the City harmless from any claims or losses from damage or disruption of private property.



Contractor shall provide, at its expense and without liability to the City, any additional land and access thereto that may be required for temporary construction facilities or for storage of materials. All such costs will be considered incidental to the work and will not result in additional cost to the City. Contractor personnel shall not unnecessarily enter upon private property without the express written consent of the landowner. The Contractor shall provide the Project Manager with a copy of the written permission. The Contractor shall indemnify and hold the City harmless from any claims or losses related to Contractor trespassing.

105.01 STORAGE OF MATERIALS

The Contractor shall confine its equipment, apparatus, the storage of materials and operations of Contractor's workmen to limits indicated by law, ordinances, permits, or directions of the City and shall not encumber the Project site with materials or equipment not necessary for the Project.

105.02 LOADING OF STRUCTURES

The Contractor shall not load or permit any part of a structure to be loaded with a weight that will endanger the structure's safety. The Contractor shall enforce the Project Manager's instructions regarding signs, advertisements, fires, and smoke.

105.03 SANITARY PROVISIONS

The Contractor shall provide and maintain on the construction site at all times suitable sanitary facilities for use of those employed on this Contract without committing any public nuisance. All toilet facilities shall be subject to the approval of the El Paso County Public Health Department. All portable toilet facilities for this Project shall be kept on City or State right-of-way as directed by the Project Manager.

105.04 ACCIDENT PREVENTION

The Contractor shall be solely responsible for initiating, maintaining, and supervising all safety precautions and programs in connection with the Work. The Contractor shall submit to the City an acceptable, comprehensive Safety Plan for review prior to commencement of the Work. The Contractor shall take all necessary precautions for the safety of, and shall provide the necessary protection to prevent damage, injury, or loss to:

- a) All persons on or about the Site or who may be affected by the Work;
- b) All Work and materials and equipment to be incorporated therein, whether in storage on or off the Site; and
- c) Other property at the site or adjacent thereto, including buildings, real property, trees, shrubs, lawns, walks, pavements, roadways, structures, utilities, and underground facilities not designated for removal, relocation, or replacement in the course of the Work.

Notwithstanding the foregoing, the City reserves the right to direct the Contractor to stop work and correct an unsafe condition at any time that any person present at the job site identifies any unsafe condition or action. For this purpose only, any person at the job site is authorized to act on behalf of the City, but such intermittent delay shall not be grounds for an increase in the Contract price or schedule.



Precaution shall be exercised at all times for the protection of persons, including employees, and property. The safety provisions of all Federal, State and Municipal laws and any other codes relating to the public safety, shall be strictly observed, and the Contractor shall, at all times, whether or not so specifically directed by the Project Manager, take the necessary precautions to ensure the protection of the public.

Piling, sheeting and shoring shall be utilized where required to prevent any excessive widening or sloughing of a trench which may be detrimental to human safety, traffic flow, a pipe being placed, trees, or to any existing structure.

Excavated materials shall be placed a safe distance from the sides of the trench. Heavy equipment shall not be used or placed near the sides of a trench unless the trench is adequately braced.

The Contractor shall not load or permit any part of a structure to be loaded with a weight that will endanger the structure's safety.

The Contractor shall designate a qualified and experienced safety representative at the Work site(s) whose duties and responsibilities shall be the prevention of accidents and the maintaining and supervising of safety plans and programs.

105.05 PROTECTION OF THE PUBLIC WORKS AND PROPERTY

The Contractor shall provide and maintain all necessary watchmen, barricades, lights, and warning signs and take all necessary precautions for the protection of the public. The Contractor shall continuously maintain adequate protection of all work from damage, and shall take all reasonable precautions to protect the City's property from injury or loss arising in connection with the Contract. The Contractor shall make good any damage, injury, or loss to their work and to the property of the City resulting from lack of reasonable protective precautions except such as may be due to errors in the Contract Documents, or caused by agents or employees of the City. The Contractor shall check all cautionary signs at least once a day during this Contract.

The Contractor shall continuously maintain adequate protection of all their work from damage and shall protect the City's and adjacent property from injury arising in connection with this Contract.

The Contractor will be responsible for any and all damage to property, public or private, that may be caused by its operations in the performance of this Contract, and the Contractor shall defend any suit that may be brought against itself or the City on account of damage inflicted by its operations, and shall pay any judgments awarded to cover such damage and shall indemnify the City for any losses arising out of such damage or related claims.

The Contractor shall be responsible for the restoration of all existing surface or subsurface improvements damaged as a result of construction at no additional cost to the City.

105.06 PUBLIC ROADS

The Contractor in executing the work on this Project shall not unnecessarily impede or interfere with traffic on public highways or streets. Detours, including surfacing, guard rails, temporary



bridges and culverts, as may be shown on the drawings, or ordered by the Project Manager to accommodate the general public, residents adjacent to the improvements, and the United States mail shall be provided and maintained by the Contractor in a good workmanlike manner. Any call out of City Barricade Crews shall be charged to and paid for by the Contractor.

All work done within the public right-of-way and/or easements requires a Traffic Control Plan approved by the City Traffic Engineering Division.

The Contractor shall provide and maintain in place all barricades, warning signs, lights and other safety devices required to protect the work, divert traffic, and warn pedestrians of open excavation, unfilled trenches, and other areas or conditions which might be hazardous or dangerous. Detour routings must first be submitted to the City Traffic Engineer for review and approval and shall be signed for the entire route of the detour as required to return the traffic to their street or origination. Detours shall be maintained throughout the period of construction in such a manner as to provide the least amount of disruption to normal traffic flow.

All signing and barricading shall conform to the latest editions of the following:

- (a) Manual of Uniform Traffic Control Devices for Street and Highways (MUTCD)
- (b) City of Colorado Springs Traffic Signage and Markings Manual
- (c) City of Colorado Springs Construction Traffic Control Manual

The City Traffic Engineer may require flag persons or off-duty police officers for traffic direction.

105.07 PROTECTION OF EXISTING CURBS, GUTTERS AND DRIVEWAYS

The Contractor shall exercise care in protecting existing curbs, gutters and driveways. Curbs, gutters and driveways damaged by the Contractor's operations shall be removed and replaced by the Contractor at Contractor's expense.

105.08 PROTECTING AND REMOVING PLANTINGS

The Contractor shall protect all existing trees, shrubs and other plantings from above ground and root structure damage during the construction activities. Plantings which are considered to be slightly damaged shall be properly pruned and sealed according to accepted nursery practices. Contractor shall be liable for the costs of any unnecessary damage to plants or trees as determined by the Project Manager. Where plantings are in conflict with new work, as determined by the City Forester (plantings in the public right-of-way) or by the inspector or owner (plantings on private property), the Contractor shall at his expense remove the planting. The Contractor shall coordinate with the City Forester prior to working in the vicinity of plantings in the public right of way.

In all cases, the proper planting season shall be observed to assure proper establishment and growth of the plantings.

Tree branches shall be trimmed back to the trunk, all around, to a minimum height of 8' above the adjacent walkway. Work shall be done only by a licensed Tree Service as provided in City Code Chapter 2, Article 3, Part 3.



105.09 PUBLIC CONVENIENCE AND SAFETY

The Contractor shall make every effort to minimize the inconvenience to property owners and to the traveling and pedestrian public, and shall conduct the Work to minimize obstruction to traffic and inconvenience to property owners affected by the Work.

The Contractor shall notify and coordinate the closing and construction of the driveways, curb, gutter and sidewalks with the Project Manager and the adjoining property owners in advance of Work in writing. The Contractor shall provide 72 hours written notice in advance of any construction that may affect access, parking and/or existing structures, including fences adjacent to that property.

Suitable access and parking will be maintained at all times. Access may be limited to half the existing driveway width for limited periods during concrete driveway and street construction. An additional verbal notice shall be provided to each business or property owner 30 minutes prior to the actual access drive closure.

Relocating of fences and structures shall be coordinated with property owners and shall include miscellaneous items including, but not limited to, utility services, street signs and mailboxes, sod replacement, sprinkler system modifications, control boxes, railroad tie walls, etc. If no such items are specifically included in the Contract, these items will be considered incidental to the work and are to be included in the unit prices. The Contractor shall coordinate the salvaging of any materials suitable for re-use with the City Inspector and, if on private property, with the respective property owners.

Any restrictions on street parking or traffic movement shall be coordinated with the City Traffic Engineer.

105.10 FAILURE TO MAINTAIN SAFE SITE

If the City becomes aware of failure to comply with applicable safety regulations, the Project Manager may inform the Contractor who shall take immediate steps to remedy the noncompliance. The Project Manager shall give written notification to the Contractor directing it to correct the unsafe acts or conditions. If the Contractor fails to comply with such a notification, the Project Manager may issue a Stop Work order in accordance with this Contract, and work shall only be resumed after adequate corrective actions have been taken to correct the safety deficiencies the Contractor has been notified of. Stoppage of work because of noncompliance with prescribed accident precaution measures shall not be considered a changed condition or changes in work, nor reason for extension of completion time.

In case of injury to persons or property by reason of failure to erect and to maintain necessary barricades, safeguards, and signals, or by reason of any act or omission of the Contractor, or Contractor's subcontractors, agents, or employees, during the performance of this Contract, the City may withhold payments due the Contractor so long as shall be reasonably necessary to indemnify the City on account of any such injuries, but the City's payment or failure to pay any sum shall not be considered a waiver of its right to indemnity under the this Contract.



105.11 EROSION AND DRAINAGE CONTROL

Contractor shall provide for the drainage of stormwater and such water as may be applied or discharged on the site in performance of the work per the latest revision of the City of Colorado Springs Drainage Criteria Manual, Volume II. Drainage facilities shall be adequate to prevent damage to the work, the site, and adjacent property.

The Contractor shall prevent the pollution of drains and watercourses by sanitary waste, sediment, debris or other substances resulting from this work. Contractor shall be required to clean up and isolate such materials on a continuing basis to prevent risk of washing into such drainage ways.

Should the affected areas of the Project exceed one acre, a Stormwater Discharge Permit shall be required. Affected area includes excavations, material stockpiles and areas where equipment and vehicles disturb the ground. An exact definition of the affected area should be obtained from the Colorado Department of Public Health and Environment (CDPHE).

105.12 POLLUTION

The Contractor shall at all times ensure compliance with applicable Federal, State, and Municipal air, water, and noise pollution laws and ordinances. The Contractor shall at all times have the proper sprinkling equipment available and shall apply water in the amount determined by each site condition or as directed by the Project Manager. The Contractor shall obtain all necessary permits at Contractor's expense, which may include, but not be limited to, El Paso County or a State Air Emission permit, State of Colorado Construction Activity permit, State of Colorado Dewatering permit and Section 404 Corp of Engineers permit, unless otherwise specified in the RFP.

105.13 TEMPORARY CONSTRUCTION

All temporary facilities, including the Contractor's field office which it may maintain at the site, and additional offices erected by subcontractors, shall be neatly constructed and arranged on the site in an orderly manner. The Contractor shall prepare and submit to the Project Manager, for approval prior to starting work, a construction plan layout, showing arrangement of storage areas, temporary buildings, equipment, and work areas. The Contractor shall provide suitable weather-tight storage sheds of capacity required to contain all materials which might be damaged by storage in the open. The Contractor shall at all times keep copies of all Contract Documents readily accessible at its office at the site.

105.14 TEMPORARY WATER SUPPLY

The Contractor shall provide, at Contractor's own expense, temporary water connections and water supply necessary for the prosecution of the work and permit all contractors on the work to use this supply at a reasonable prorated charge, or by sub-metering. The Contractor shall pay for all water consumed in the work, and shall arrange with Colorado Springs Utilities for temporary connections and payment of service charges. Upon completion of the Contract work, all temporary waterlines shall be removed. The City will devise a method and plan to monitor and enforce the proper use of temporary water. The City will inspect for compliance.



105.15 TEMPORARY ELECTRICITY

The Contractor shall arrange with the Colorado Springs Utilities for temporary electricity necessary for the prosecution of the work. The Contractor shall pay for all electric current consumed, and shall permit all contractors on the work to use this supply at a reasonable prorated charge, or by sub-metering.

105.16 TEMPORARY HEAT

The Contractor shall provide adequate, temporary heat required during construction. Until the building or work area is enclosed, heavy tarpaulin shall be used to enclose any space requiring heating or protection from weather during construction operations. After the heating plant is in operating condition and the building is enclosed, heat may be provided from the permanent heating plant if such is approved by the Project Manager. In such case, the Contractor shall arrange to operate the plant, connect permanent or temporary radiation or unit heaters, and so maintain the plant during operation that it will be turned over to the City undamaged at the completion of the work. The Contractor shall provide all fuel required. In no case shall salamander heating be used in finished or plastered surfaces; instead, gas-steam radiators, unit heaters, or other suitable and approved means shall be used if the permanent heating plant is not available. This applies only to structures. It does not apply to road improvements or other outdoor improvements.

105.17 TEMPORARY ENCLOSURES

The Contractor shall provide and maintain temporary enclosures for the work as may be required to permit continuation of interior work during inclement weather, if wall and roof construction has progressed sufficiently to make interior work possible. This applies only to structures. It does not apply to road improvements or other outdoor improvements.

105.18 CLEAN-UP

The Contractor shall at all times keep the work area including storage and staging areas, free from accumulations of waste materials. The Contractor is also responsible for any costs associated with cleanup of debris from the work site or storage areas that may inadvertently be scattered outside the area by weather or vandalism. Upon completion of the work, the Contractor shall leave the work area in a clean neat and orderly condition satisfactory to the Project Manager.

SECTION 106 ROYALTIES, PATENT INFRINGEMENTS, SPECIAL LICENSES AND PERMITS

106.00 ROYALTIES AND PATENTS

The Contractor shall pay all applicable royalties and license fees. The Contractor shall defend all suits or claims for infringement of any patent rights and save the City harmless from loss on account thereof except that the City may be responsible for any such loss when a particular process, design, or the product of a particular manufacturer or manufacturers is specified, unless the City has notified the Contractor prior to the signing of the Contract that the particular process, design, or product is patented or is believed to be patented.



SECTION 107 WORK PROVISIONS AND RULES

107.00 COMMENCEMENT AND COMPLETION OF WORK

- (a) Preconstruction Conference. After issuance of Notice to Proceed, or as otherwise established by the City, a preconstruction conference (“Preconstruction Conference”) shall be held for review of the construction schedule, Contractor’s written list of subcontractors and suppliers, written list of all required permits, project contracts, utility support plan, water control plan, Traffic Control Supervisor name and telephone number, gradations, test results, certifications, review procedures for handling shop drawings and other submittals, processing applications for payment, and other pertinent items.
- (b) At the Preconstruction Conference, the Contractor shall furnish the Project Manager a written list of all permits required for the proper completion of the Contract. The list shall clearly identify the type of permit or permits that must be obtained before work on any particular phase or phases of work can be started.
- (c) The Contractor shall commence work within ten (10) Calendar Days of the date specified on the Notice to Proceed and complete the Contract within the number of Calendar Days or by the date specified in the proposal form. Unless otherwise noted in the Contract, the number of days are Calendar Days.
- (d) The dates fixed for commencement and completion of the work may be extended by the Project Manager. All requests for extension of time by the Contractor shall be made in writing to the Project Manager and shall set forth the reasons for such requests. The Project Manager may fix the period of extension, if any. In addition, the Project Manager may grant a period of extension upon an execution of a Change Order. Any Project Manager’s decision on extensions of time shall be binding upon the parties hereto. Requests for extension of time received twenty (20) or more days after the occurrence of the delay will not be honored. No requests for extension of time shall be honored if submitted after the completion date.
- (e) If satisfactory execution and completion of the Contract shall require work or materials in greater amounts or quantities other than those set forth in the Contract, then the Contract time may be adjusted at the time of the execution of the Change Order. No allowance will be made for delays or suspension of the prosecution of the work due to the fault of the Contractor.

107.01 FAILURE TO COMPLETE WORK ON TIME, LIQUIDATED DAMAGES

If the Contractor fails to fully perform and complete the work in conformity to the provisions and conditions of the Contract within the specified time limit set forth in the Contract, including any extensions granted hereto, the Contractor may be subject to a stop work order, as provided in this Contract. In addition, the Contractor shall pay to the City for each Calendar Day of delay until such time the Contract is complete, liquidated damages at the applicable daily rate below. The amounts shown are considered to be liquidated damages to reimburse the City for the additional cost of construction engineering and Contract administration services and in no case are considered a penalty.

Original Contract Amount	Amount of Liquidated Damages Per Day
Less than \$50,000	\$300.00



\$50,000 to \$100,000	\$500.00
\$100,000 to \$500,000	\$700.00
\$500,000 to \$1,000,000	\$900.00
Over \$1,000,000	\$1500.00

107.02 WORK IN BAD WEATHER

No construction work shall be done during stormy, freezing, or inclement weather, except such as can be done satisfactorily, and in a manner to secure first class construction throughout, and then only subject to permission of the Project Manager.

The granting of a time extension for inclement weather does not imply or guarantee that additional compensation for incidental and appurtenant work caused by such weather will be approved or authorized by the Project Manager. Weather delays that can be reasonably anticipated shall not result in increased cost to the City. The Project Manager will be the sole judge as to the reasonableness of delays for inclement weather.

107.03 EXCUSABLE DELAYS

The Contractor's right to proceed will not be terminated, and the Contractor will not be charged with damages, for delays in completing the work that arise from unforeseeable causes beyond the control and without the fault or negligence of the Contractor. Examples of such causes include:

- (a) Acts of God or of the public enemy,
- (b) Acts of the government in either its sovereign or Contractual capacity,
- (c) Acts of another contractor in the performance of a contract with the government,
- (d) Fires,
- (e) Floods,
- (f) Epidemics,
- (g) Quarantine restrictions,
- (h) Strikes of employees other than Contractor's employees,
- (i) Freight Embargos,
- (j) Unusually severe weather, or
- (k) Delays of subcontractors or suppliers at any tier arising from unforeseeable causes beyond the control and without the fault or negligence of both the Contractor and the subcontractors or suppliers.

107.04 COMPENSATION FOR COMPENSABLE DELAYS

If the Project Manager determines that a delay is compensable in accordance with the Contract, monetary compensation will be determined in accordance with this subsection.

- (a) These categories represent the only costs that are recoverable by the Contractor. All other costs or categories of costs are not recoverable:
 - 1. Actual, reasonable wages and benefits, including FICA, paid for additional non-salaried labor;
 - 2. Reasonable and actual costs for additional bond, insurance and tax;
 - 3. Increased, reasonable, and actual costs for materials;



4. Reasonable equipment costs calculated in accordance with the current edition of the Rental Rate Blue Book of Rental Rates for Construction Equipment for Contractor-owned equipment and based on invoice costs for rented equipment;
 5. Reasonable and actual costs of extended job site overhead;
 6. Reasonable subcontractor's claims (the same level of detail as specified herein is required for all subcontractors' claims)
 7. An additional 10 percent will be added to the total of items (1), (2), (3), (4), (5), and (6) as compensation for items for which no specific allowance is provided, including profit, overhead, and general and administrative expenses.
- (b) In adjustment for costs as allowed above, the City will have no liability for the following items of damages or expense:
1. Profit in excess of that provided in (a) above;
 2. Loss of profit;
 3. Additional cost of labor inefficiencies in excess of that provided in (a) above;
 4. Home office or other overhead or general and administrative expenses in excess of that provided in (a) above;
 5. Consequential damages, including but not limited to loss of bonding capacity, loss of bidding opportunities, and insolvency;
 6. Indirect costs or expenses of any nature in excess of that provided in (a) above;
 7. Attorney's fees, claim preparation fees, and expert fees.

All costs claimed must be documented and accompanied by a written certification from the Contractor.

107.05 EMERGENCY WORK

In an emergency affecting the safety of life or of the work or of adjoining property, the Contractor is, without special instructions or authorization from the Project Manager, hereby permitted to act at Contractor's discretion to prevent such threatening loss or injury. Contractor shall also act, without appeal, if so authorized or instructed by the Project Manager. Any reasonable compensation claimed by the Contractor on account of emergency work shall be determined by mutual agreement or in accordance with the Changes provision of this Contract.

107.06 VALUE ENGINEERING CHANGE PROPOSALS BY THE CONTRACTOR

The Contractor is encouraged to develop and offer proposals for improved construction techniques, alternative materials and other innovations. Proposals must provide a project comparable to the City's original design either at lower cost, with improved quality, or both. If a Value Engineering Change Proposal (VECP) Proposals shall be submitted only after contract award. If a VECP is rejected, the work shall be completed in accordance with the Contract at the Contract price. The Contractor shall have no claim against the City for compensable or noncompensable delay to the Contract based on the failure to respond to a VECP.

The Contractor may submit either a full VECP or a preliminary Conceptual VECP, followed by a full proposal. The City Engineer will provide timely review of all VECPs and advise the Contractor whether the VECP is complete or incomplete. When the VECP is complete, the Project Manager will advise the Contractor of either the approval of the VECP or the reasons for rejection of the VECP.



Cost savings generated to the Contract as a result of VECPs offered by the Contractor and accepted by the Project Manager shall be shared equally between the Contractor and the City.

If the Project Manager determines that the time for response indicated in the submittal under item (c)5 below is insufficient for review, the Contractor will be promptly notified. Based on the additional time needed by the Project Manager for review and the effect on the Contractor's schedule caused by the added time, the Project Manager will evaluate the need for a non-compensable time adjustment to the Contract.

(a) VECPs that will be considered are those that would produce savings to the City or provide improved Project quality without impairing essential functions and characteristics of the Project. Essential functions include but are not limited to: service life, economy of operation, ease of maintenance, desired appearance, safety, and impacts to the traveling public or to the environment during and after construction.

(b) *Submittal of Conceptual Proposal.* For VECPs that require a significant amount of design or other development resources, the Contractor may submit an abbreviated conceptual proposal for preliminary evaluation. The Project Manager will evaluate the information provided and advise the Contractor if any conditions or parameters of the conceptual proposal are found to be grounds for rejection. Preliminary review of a conceptual proposal reduces the Contractor's risk of subsequent rejection but does not commit the City to approval of the full VECP. The following information shall be submitted for each conceptual proposal.

1. A statement that the proposal is submitted as a conceptual VECP.
2. A general description of the difference between the existing Contract and the proposed change, and the advantages and disadvantages of each, including effects on cost, service life, economy of operation, ease of maintenance, desired appearance, safety, and impacts to the traveling public or to the environment during and after construction.
3. A set of conceptual plans and a description of proposed changes to the Contract specifications.
4. An estimate of the anticipated cost savings or increase.
5. A statement specifying:
 - a. when a response to the conceptual proposal from the City is required to avoid delays to the existing contract prosecution,
 - b. the amount of time necessary to develop the full Proposal,
 - c. the date by which a Change Order must be executed to obtain maximum benefit from the VECP, and
 - d. the VECP's impact on time for completing the Contract.

(c) *Submittal of Full Value Engineering Change Proposal.* The following materials and information shall be submitted with each VECP.

1. A statement that the proposal is submitted as a VECP.
2. A description of the difference between the existing Contract and the proposed change, and the advantages and disadvantages of each, including effects on service life, economy of operation, ease of maintenance, desired appearance, safety, and impacts to the traveling public or to the environment during and after construction.
3. A complete set of plans and specifications showing the proposed revisions relative to the original Contract. This portion of the submittal shall include design notes and



construction details. The proposed plans and specifications shall be signed and sealed by the Contractor's engineer.

4. A complete analysis indicating the final estimated costs and quantities to be replaced by the VECP compared to the new costs and quantities generated by the VECP. All costs and proposed unit prices shall be documented by the Contractor.
5. A statement specifying the date by which a Change Order must be executed to obtain the maximum cost reduction during the remainder of the Contract.
6. A statement detailing the effect the VECP will have on the time for completing the Contract.
7. A description of any previous use or testing of the proposed changes and the conditions and results. If the VECP was previously submitted on another City project, the VECP shall indicate the date, Contract number, and the action taken by the City.
8. An estimate of any effects the VECP will have on other costs to the City.
9. A statement of life cycle costs, when appropriate. Life cycle costs will not be considered as part of cost savings but shall be calculated for additional support of the VECP. A discount rate of four percent shall be used for life cycle calculations.
10. A statement specifying when a response from the City is required to avoid delays to the prosecution of the Contract.

(d) *Evaluation.* VECPs will be evaluated in accordance with the following:

1. The Project Manager will determine if a VECP qualifies for consideration and evaluation. The Project Manager may reject any VECP that requires excessive time or costs for review, evaluation, or investigations. The Project Manager may reject proposals that are not consistent with the City's design policies and criteria for the Project.
2. VECPs, whether or not approved by the City, apply only to this Contract and become the property of the City. VECPs shall contain no restrictions imposed by the Contractor on their use or disclosure. The City has the right to use, duplicate and disclose in whole or in part any data necessary for the utilization of the Proposal. The City retains the right to utilize any accepted VECP or part thereof on other projects without obligation to the Contractor. This provision is subject to rights provided by law with respect to patented materials or processes.
3. If the City is able to demonstrate that it is already considering certain revisions to the Contract, prior to receipt of the VECP, or has approved certain changes in the Contract for general use that are subsequently proposed in a VECP, the Project Manager will reject the VECP and may proceed to implement these changes without obligation to the Contractor.
4. The Contractor shall have no claim against the City for additional costs or delays resulting from the rejection or untimely acceptance of a VECP. These costs include but are not limited to: development costs, loss of anticipated profits, increased material or labor costs, or untimely response.
5. VECP will be rejected if equivalent options are already provided in the Contract.
6. VECP that only reduce or eliminate Contract pay items will be rejected.
7. The savings generated by the VECP must be sufficient to warrant a review and processing, as determined by the Project Manager.
8. A VECP changing the type or thickness of the pavement structure or changing the design of a bridge will be rejected.
9. Additional information needed to evaluate VECPs shall be provided in a timely manner. Untimely submittal of additional information will result in rejection of the VECP. Where



design changes are proposed, the additional information shall include results of field investigations and surveys, design and computations, and changed plan sheets required to develop the design changes.

- (e) *Payment.* If the VECP is accepted, the changes and payment will be authorized by a Change Order. Reimbursement will be made as follows:
1. The changes will be incorporated into the Contract by changes in quantities of unit items, new agreed unit price items, or both, as appropriate, under the Contract.
 2. The Price of the contract will be revised to reflect the changes in the VECP. The City will pay the Contractor 50 percent of the savings to the City upon completion of the Project. The savings to the City shall be the difference between the cost of the revised work and the cost of the related construction required by the original Contract computed at Contract prices.
 3. Costs incurred by the Contractor for development, design, and implementation of the VECPs will not be reimbursed.
 4. When work performed under an approved VECP is modified to fit field or other conditions, the maximum amount paid for the work will be limited to that which would have been paid if the work had been performed under the original Contract provisions. The rejection or limitation of reimbursement shall not constitute the basis of any claim against the City for delay or for other costs except as allowed under the original Contract.

107.07 AUTHORITY OF THE PROJECT MANAGER

The Project Manager will decide all questions regarding the quality and acceptability of materials furnished, work performed, and the rate of progress of the work, all interpretation of the plans and specifications, and the acceptable fulfillment of the Contract. The Project Manager will perform technical inspection of the work and shall have authority to reject all work and materials which do not conform to the Contract.

The Project Manager has authority to stop the work whenever such stoppage may be necessary to insure the proper execution of the Contract or for the convenience of the City. The Project Manager may order the Contractor, by giving ten (10) days written notice, to suspend, delay, or interrupt all or any portion of the work required by the Contract for a period of up to (10) ten Calendar Days at no additional cost to the City. The Project Manager may immediately stop the work when it is determined that the public's safety and welfare is in jeopardy.

The Project Manager will, within a reasonable time after their presentation to the Project Manager, make decisions in writing on all claims submitted to the City by the Contractor and on all other matters relating to the execution and progress of the work or the interpretation of the Contract Documents. The Project Manager's decisions shall be final.

107.08 DUTIES OF THE INSPECTOR

Inspectors employed by the City are authorized to inspect all work done and materials furnished. Any such inspection may extend to all or any part of the work and to the preparation, fabrication or manufacture of the materials to be used. An inspector is not authorized to alter or waive the provisions of the Contract. An inspector is not authorized to issue instructions contrary to the provisions of the Contract or to act as foreman for the Contractor.



107.09 CONSTRUCTION OBSERVATION AND INSPECTION

The Project Manager shall at all times have access to the work, and the Contractor shall provide proper equipment, materials and labor as required for such access and inspection.

All equipment, material, and articles incorporated into the work covered by this Contract shall be new and of the most suitable grade for the purpose intended, unless otherwise specifically provided in this Contract. The Project Manager shall have the right to reject materials and workmanship, which are defective, or require their correction. Rejected workmanship shall be satisfactorily corrected and rejected materials shall be removed from the premises and replaced without charge to the City. If the Contractor does not correct such rejected work and remove rejected materials within a reasonable time fixed by written notice, the City may remove them and charge the expense to the Contractor.

Should it be considered necessary or advisable by the Project Manager at any time before final acceptance of the entire work to make an examination of work already completed, by removing or tearing out same, the Contractor shall on request promptly furnish necessary facilities, labor and materials. If such work is found to be defective in any material respect due to fault of the Contractor or his subcontractors, he shall defray all the expenses of such examination and of satisfactory reconstruction. If, however, such work is found to meet the requirements of the Contract, the actual, reasonable cost of labor and material necessarily involved in the examination and replacement, plus ten (10) percent, will be allowed the Contractor.

All materials to be incorporated in the work, all labor performed, all tools, appliances, and methods used shall be subject to the inspection and approval or rejection of the Project Manager.

If the Project Manager points out to the Contractor, Contractor's foreman, or agent any neglect or disregard of the Contract provisions, such neglect or disregard shall be remedied and further defective work be discontinued immediately.

The Contractor shall execute the work only in the presence of the Project Manager or authorized representative, unless provision has been made for the work to proceed without complete engineering supervision or inspection. The presence of the Project Manager or authorized representative shall in no way relieve the Contractor of any responsibility under this Contract.

The observation of the work by the Project Manager is intended to aid the Contractor in applying labor, materials, and workmanship in compliance with the Contract provisions. Such observation, however, shall not relieve the Contractor from any of Contractor's Contract obligations.

107.10 CONTRACTOR COOPERATION

All work under this Contract shall be performed in a skillful and professional manner. The Project Manager shall have the authority to order the Contractor to remove from the work site any employee the Project Manager deems incompetent, careless, or otherwise objectionable to the general public or the City by notify the Contractor of such order in writing.

(a) Workmen, Methods and Equipment: Permission from the Project Manager to use any particular methods, equipment or appliances shall not be so construed as to relieve the



Contractor from furnishing other equipment or appliances or adopting other methods when those in use prove unsatisfactory to the Project Manager, or as to bind the Project Manager to accept work which does not comply with the Contract.

107.11 CONTRACTOR'S RESPONSIBILITY FOR WORK

Until the work is accepted by the Project Manager as evidenced by the issuance of the Certificate of Completion, the Contractor shall have the charge and care thereof and shall take every necessary precaution against injury or damage to any part thereof by action of the elements or from any other cause, whether arising from the execution or from the non-execution of the work. The Contractor shall rebuild, repair, restore, and make good all injuries or damages to any portion of the work occasioned by any of the above causes before its completion and acceptance and shall bear the expense thereof.

The Contractor shall be responsible for the preservation of all public and private property, trees, fences, monuments, and other property, along and adjacent to the improvements and shall use suitable precautions necessary to prevent damage to pipes, conduits, and other underground structures. When or where any direct or indirect damage or injury is done to public or private property by or on account of any act, omission, neglect or misconduct in the execution of the work, or in consequence of the non-execution thereof on the part of the Contractor, such property will be restored by the Contractor and at Contractor's expense to a condition similar, or equal to that existing before such damage or injury to the satisfaction of the City's Project Manager.

It shall be the responsibility of the Contractor, when moving or operating equipment, to make all arrangements for temporary crossings of telephone, transmission, pipe lines, railroad tracks, and irrigation ditches. This work shall not be paid for as a separate item but shall be considered as incidental to the project.

107.12 PROTECTION OF UTILITIES

The Contractor's attention is directed to the fact that utilities may encroach on the construction of this Project, and also to the importance of protecting all public/private utilities encountered on this project. These may include telecommunications, cablevision, traffic signal lines, power lines, water lines, sewer lines, gas lines, railroad tracks, and other overhead and underground utilities.

The City does not warrant any survey work or location of utilities or other underground apparatuses whether performed by the City, its agent, or an independent contractor. Contractor understands and agrees any survey or location work performed by the City, its agent, or other independent contractor is provided for guidance purposes only, so as to show the approximate location of underground utilities or apparatuses. Contractor understands the existence or exact location of underground utilities or apparatuses may not be known to the City or the design engineer of record. Contractor, therefore, agrees that it shall verify the existence and location of any underground utilities or apparatus along the route of work. Verification shall be done by potholing or using other methods which will detect the exact depth, dimensions, and location of any underground utilities or apparatus.

Contractor shall be liable for any damages, loss, or claims of whatsoever kind caused by its failure to pothole or use other methods of identifying the exact depth, dimensions, and location of any underground utilities or apparatus. Contractor agrees that any claim of any kind whatsoever,



damages, loss, lawsuit, demand, or request for equitable adjustment (“Claims”), shall be waived and the City shall be forever released and discharged from such Claims if Contractor fails to comply with its obligations under this section. Contractor agrees that if it fails to maintain all records or other evidence establishing that it potholed or otherwise determined the exact location, depth, and dimensions of all underground utilities and apparatuses, then it shall not be permitted to make any Claim arising from or related to the location of underground utilities or apparatus.

The size and location of all existing utilities as known to the Project Manager have been noted on the plans for the information and guidance of the Contractor. The Contractor shall be responsible for the location and protection of all utilities located within his working area regardless of whether or not their existence or location is shown or noted on the drawings.

It is the Contractor’s responsibility to complete required work and to schedule inspections during normal working hours. The Contractor is responsible for contacting each affected utility for their inspectors’ working hours. The Contractor is responsible to request an inspection two (2) working days in advance of the inspection. In the case of an overtime inspection, the request must be in writing. All overtime costs for inspection by Colorado Springs Utilities, or other utilities personnel, shall be the Contractor’s expense. The City will not entertain any requests for time extensions for delays caused by the Contractor’s failure to properly notify the affected utility of a required inspection or the Contractor’s failure to complete the required work by the time of the scheduled inspection.

Any information concerning underground utilities shown on the drawings is intended to be merely an aid to the Contractor. The accuracy of information with respect to underground utilities is not guaranteed. The Contractor shall make their own investigation, including exploratory excavations, to determine the locations and type of existing mains or service laterals or appurtenances when their presence can be inferred from the presence of other visible facilities, such as building, manholes, inlets, meters and junction boxes, on or adjacent to the site of the work. If the Contractor discovers utility facilities not identified in the plans or specifications or in a position different from that shown in the plans and specifications, the Contractor shall immediately notify, verbally and in writing, the Project Manager and Owner of the utility facility.

Before any excavation is begun in the vicinity of water lines, railroad tracks, or structures, sewer lines, telecommunication conduits or cablevision line, each utility company, including Colorado Springs Utilities (if applicable), department, or company concerned must be notified in advance of such excavation, and such excavation shall not be made until an authorized representative of the utility concerned is at the site.

All utilities encountered must be kept in operation by the Contractor and must be protected and/or repaired at the Contractor's own expense, unless otherwise specified in the Contract documents. The Contractor shall be held liable for all damages to any and all public utilities encountered on the project, which damages are due to the Contractor's operations. Such damages shall include all physical damages to utilities and also all damages due to interruption of service of such utilities, when such damages and interruptions are caused by the Contractor's operations.

Where alterations or moving of utilities is not required to permit construction of the project, the Contractor shall take such measures as the Project Manager may direct to properly protect these utilities throughout his construction operations and shall cooperate at all times with the proper



authorities and/or owners in maintaining service of railroads, conduits, pole lines, transmission lines, pipe lines, sewers, etc., affected by this project.

The costs of damages due to the Contractor's operation shall not be allowable under this Contract and shall result in no additional cost to the City. The cost of protecting utilities where alteration or relocation is not required to permit construction of the project shall be considered as included in the original Contract price for the project and shall result in no additional cost to the City.

Should any pipe line, water lines, or gas mains, electrical conduits, sewer pipes, overhead wiring, telecommunication lines, power lines, or any other such utilities, not specifically mentioned and provided for elsewhere as a part of this Contract, have to be moved, repaired, reconditioned, or revised due to the construction, or moved temporarily to permit construction of the project the party or parties owning and operating such utilities shall perform the actual work of moving, repairing, reconditioning, or revising such utilities. Any such work would be added via change order, and the cost of this work will be borne by Colorado Springs Utilities, the utility company's involved, or other means arranged by the City.

(a) Existing Utilities

1. Existing Gas Lines: As of April 1, 1983, Federal law requires anyone who uncovers a gas line to report it to the gas company and allow it to be inspected by the gas company personnel before it is backfilled. Colorado Springs Utilities or other provider is to be notified prior to any excavation around gas lines. A Colorado Springs Utilities. or other applicable provider. inspector is to be notified and present on site prior to construction activities around gas lines.
2. Existing Sewer Mains and Services: All relocation, replacement protection shown on the plans or determined necessary by the inspector shall be performed according to the latest Colorado Springs Utilities Wastewater Standard Specifications. Minimum 48 hours' notice must be given to Colorado Springs Utilities prior to any related work.
3. The Contractor shall adjust sanitary sewer manhole rims to an elevation acceptable to Colorado Springs Utilities. The Contractor shall contact Colorado Springs Utilities twenty-four (24) hours prior to manhole rim adjustments.
4. Existing Water Mains and Services: All relocation, replacement or protection shown on the plans or determined necessary by the inspector shall be performed according to the latest Colorado Springs Utilities Water Standard Specifications and the Water Service Standard Specifications. Minimum 48-hour notice must be given to Colorado Springs Utilities prior to any related work. Colorado Springs Utilities reserves the right to schedule any operations at their discretion and to provide for any requirements determined necessary to perform the work. The Contractor shall coordinate with the Colorado Springs Utilities and receive their approval prior to performance of the work.

(b) Utility Support Systems:

1. If required by the Contract documents, or requested by the Project Manager, the Contractor shall submit shop drawings for the method of temporary support for all existing utilities during construction. The temporary support details for existing utilities shall be submitted for review and approval prior to performance of the work. Shop drawings must bear the seal of a Professional Project Manager registered in the State of Colorado, unless so waived by the City.
2. Regardless of City approved shop drawings, the Contractor shall be responsible for the satisfactory support of the utility system and any damages that may occur to the utility involved.



(c) Electric Utility Installation:

1. Any electric facilities unless otherwise noted are to be relocated or modified by Colorado Springs Utilities. The Contractor shall coordinate the work with Colorado Springs Utilities and Colorado Springs Utilities Contractor.
2. Light Pole Installation or Relocation:
 - i. The Contractor is responsible for coordinating with Colorado Springs Utilities, removing existing light pole foundations, constructing new light pole foundations, installing new conduits, and installing lighting junction boxes. The Contractor is responsible for coordinating with Colorado Springs Utilities for the de-energizing and removal of existing light poles.
 - ii. Colorado Springs Utilities will remove the existing light standards, reset the light standards upon completion of the new foundations, conduit and junction boxes, pulling wire, and beginning operations of the lighting within the project limits. The Contractor is responsible for scheduling and coordination with Colorado Springs Utilities crews for reinstallation and re-energizing completed light poles.

(d) Gas Utilities: The Contractor is responsible for coordinating with Colorado Springs Utilities for the relocation of existing Gas lines. Colorado Springs Utilities will relocate the existing gas lines as necessary to install project improvements within the project limits. The Contractor is responsible for scheduling and coordination with Colorado Springs Utilities crews.

(e) Telecommunication Agencies: Any telephone facilities unless otherwise noted are to be relocated or modified by the respective private utility company. The Contractor shall coordinate the work with the respective private utility company.

(f) Cablevision: The television utilities are to be relocated by the cable provider. The Contractor shall coordinate the work with any affected cable provider.

107.13 FEDERAL FUNDS

If this Contract is a federally assisted construction contract all applicable federal requirements, terms and conditions, provisions and forms shall apply. Additionally, during the performance of this Contract, the Contractor agrees as follows:

1. The Contractor will not discriminate against any employee or applicant for employment because of race, color, religion, sex, sexual orientation, gender identity, or national origin. The Contractor will take affirmative action to ensure that applicants are employed, and that employees are treated during employment, without regard to their race, color, religion, sex, sexual orientation, gender identity, or national origin. Such action shall include, but not be limited to the following: employment, upgrading, demotion, or transfer; recruitment or recruitment advertising; layoff or termination; rates of pay or other forms of compensation; and selection for training, including apprenticeship. The Contractor agrees to post in conspicuous places, available to employees and applicants for employment, notices to be provided by the contracting officer setting forth the provisions of this nondiscrimination clause
2. The Contractor will, in all solicitations or advancements for employees placed by or on behalf of the Contractor, state that all qualified applicants will receive consideration for employment without regard to race, color, religion, sex, sexual orientation, gender identity, or national origin.
3. The Contractor will not discharge or in any other manner discriminate against any employee or applicant for employment because such employee or applicant has inquired about, discussed, or disclosed the compensation of the employee or applicant or another employee



or applicant. This provision shall not apply to instances in which an employee who has access to the compensation information of other employees or applicants as a part of such employee's essential job functions discloses the compensation of such other employees or applicants to individuals who do not otherwise have access to such information, unless such disclosure is in response to a formal complaint or charge, in furtherance of an investigation, proceeding, hearing, or action, including an investigation conducted by the employer, or is consistent with the contractor's legal duty to furnish information.

4. The Contractor will send to each labor union or representative of workers with which he has a collective bargaining agreement or other Contract or understanding a notice advising the labor union or workers representative of the Contractor's commitments under Section 202 of Executive Order No. 11246 of September 24, 1965, and shall post copies of the notice in conspicuous places available to employees and applicants for employment.
5. The Contractor will comply with all provisions of Executive Order 11246 of September 24, 1965, and of the rules, regulations, and relevant orders of the Secretary of Labor.
6. The Contractor will furnish all information and reports required by Executive Order 11246 of September 24, 1965, and by the rules, regulations and orders of the Secretary of Labor, or pursuant thereto, and will permit access to his books, records, and accounts by the Secretary of Labor, State of Colorado Civil Rights Commission and any other governmental agency entity which may be assisting with the funding under this Contract for purposes of investigation to ascertain compliance with such rules, regulations and orders.
7. In the event of the Contractor's noncompliance with the nondiscrimination clauses of this Contract or with any such rules, regulations, or orders, this Contract may be cancelled, terminated, or suspended in whole or in part, and the Contractor may be declared ineligible for further government Contracts or Federally assisted construction Contracts in accordance with the procedures authorized in Executive Order No. 11246 of September 24, 1965, and such other sanctions may be imposed and remedies invoked as provided in Executive Order No. 11246 of September 24, 1965, or by rule, regulation, or order of the Secretary of Labor, or otherwise provided by law.
8. The Contractor shall include the provisions of Paragraphs (1) through (8) in every subcontract or purchase order unless exempted by rules, regulations, or orders of the Secretary of Labor issued pursuant to Section 204 of Executive Order No. 11246 of September 24, 1965, so that such provisions will be binding upon each subcontractor or vendor. The Contractor will take such action with respect to any subcontract or purchase order as the city, state, or any federal governmental entity may direct as a means of enforcing such provisions, including sanctions for noncompliance. Provided, however, that in the event the Contractor becomes involved in, or is threatened with, litigation with a subcontractor or vendor as a result of such direction, the Contractor may request the city, the state, or the United States to enter into such litigations to protect the interests of such governmental entity.

107.14 SUPERINTENDENCE

The Contractor shall give the work the constant attention necessary to facilitate the progress thereof and shall cooperate with the Project Manager and with other contractors or Colorado Springs Utilities employees in every way possible. The Contractor shall have at all times, on the work, as Contractor's agent, a competent superintendent capable of reading and thoroughly understanding the Plans and Specifications, and who shall have the necessary authority to receive and promptly execute the instructions and orders from the Project Manager or the Project Manager's authorized representative. Such superintendent shall be furnished irrespective of the amount of work sublet. The Contractor shall supply the Project Manager with a list of phone



numbers at which the Contractor and its superintendent and foreman can be reached at any time. The assigned superintendent must adhere to the cooperation requirements specified in this Contract and is subject to removal if so ordered in writing by the Project Manager.

107.15 PREPARATION

All vegetation, stumps, and debris and other objectionable objects shall be removed from the area staked out by the Project Manager, and where necessary from the area immediately adjacent thereto. Such debris shall be hauled from the site of the construction and wasted as directed by the Project Manager.

107.16 STAKING WORK

The Project Manager may provide reference points (horizontal and vertical control) only, unless otherwise noted in the proposal and project specifications. The Contractor shall engage the services of a licensed surveyor or surveying firm (hereinafter referred to as the Surveyor) to be approved by the Project Manager. The Surveyor shall perform all detailed construction layout and staking including the staking of all storm sewer, street improvements, and utility relocations in accordance with the plans and specifications. The Contractor shall be responsible for the correctness and accuracy of the detailed layout of finished structures.

Any instrument man or survey assistant employed on the work by the Contractor or his subcontractors, who are judged by the Project Manager to be incompetent, shall be removed from the work and replaced by a competent individual.

107.17 DEVIATION ALLOWED

Finished surfaces in all cases shall conform to lines, grades, cross sections and dimensions shown on the approved drawings or described in the Specifications. Deviations from the approved drawings and working drawings as may be required by the expediencies of construction, in all cases, must be determined by the Project Manager and authorized in writing. If the Project Manager deems it inexpedient to correct work injured or done in an unauthorized manner, an equitable deduction from the Contract price of the work done shall be made by the Project Manager subject to approval of the City Procurement Services Manager.

107.18 RIGHT-OF-WAY

The City's right-of-way will in general be adequate for construction purposes. Nothing marked on the drawings shall be interpreted as giving the Contractor exclusive occupancy of the territory provided by the City. The City and its employees for any purpose, and other contractors of the City, for any purpose required by their respective contracts, may enter upon or occupy any portion of the land furnished by the City. When the territory of one contract is a necessary or convenient means of access for the execution of another contract, such privileges of access or any other reasonable privilege shall be granted by the Contractor to the extent, amount, in the manner and at times necessary. No such joint occupancy or use of the territory shall be made as the basis of any claim for delay or damages.

107.19 SHOP DRAWINGS AND SUBMITTALS



The Contractor shall submit to the Project Manager all shop drawings and submittals required for the work, including those pertaining to structural and reinforcing steel within fifteen (15) Calendar Days from the date of the Notice of Award. The Contractor shall make any corrections in the drawings required by the Project Manager and resubmit the same without delay.

Three final copies of all shop drawings (if applicable), submittals (if applicable) and schedules shall be submitted to the Project Manager, who after checking will retain two copies and return one copy to the Contractor. The Project Manager's approval of shop drawings of equipment and material shall extend only to determining the conformity of such equipment and materials with the general features of the design drawings prepared by the Project Manager. It shall be the responsibility of the Contractor to determine the correctness of all dimensions and minor details of such equipment and materials so that when incorporated in the work, correct operations will result.

107.20 RECORD DRAWINGS

The Contractor shall maintain an up-to-date set of Contract drawings and Contract records, legibly marked; depicting all constructed improvements at the site or as otherwise specified and shall submit a complete set labeled "Project Record" to the Project Manager upon completion of the Project.

- 1) Drawings:
 - a) Depths of various elements of foundation in relation to finish floor datum.
 - b) Horizontal and vertical locations of underground utilities and appurtenances, referenced to permanent surface improvements and Project survey control.
 - c) Location of internal utilities and appurtenances concealed in the construction, referenced to permanent surface improvements and project survey control.
 - d) Field changes of dimensions and detail.
 - e) Changes made by Change Order.
 - f) Details not on original Contract drawings.
- 2) Specifications and Addenda:
 - a) Manufacturer, trade name, catalog number, and supplier of each product and item of equipment actually installed.
 - b) Changes made by Change Order.

107.21 MATERIALS

Unless otherwise stipulated in the Specifications, all workmanship, equipment, materials, and articles incorporated in the work covered by this Contract are to be new and of the best grade of their respective kinds for the purpose. The Contractor shall furnish to the Project Manager for the Project Manager's approval, the name of the manufacturer of machinery, mechanical and other equipment, which he contemplates installing, together with their performance capacities and other pertinent information including but not limited to instruction manuals pertaining to the use and operation of such machinery, mechanical and other equipment.

When required by the Specifications, or when called for by the Project Manager, the Contractor shall furnish for approval full information concerning the materials or articles which he contemplates incorporating in the work. Samples of materials shall be submitted for approval



when so directed. Machinery, equipment, materials, and articles installed or used without such approval shall be at the risk of subsequent rejection.

107.22 MATERIAL INSPECTION AT PLANT

If the Project Manager inspects the materials at the source, the following conditions shall be met:

- (a) The Project Manager shall have the cooperation and assistance of the Contractor and the materials producer.
- (b) The Project Manager shall have full entry to all parts of the plant necessary for the manufacture or production of the materials being furnished.
- (c) Adequate safety measures shall be provided and maintained.

The City reserves the right to retest all materials which have been previously tested or inspected. The retesting may be prior to or after incorporation of the materials into the work. Those materials inspected and tested after delivery on the Project or after incorporation into the work that do not meet the requirements of the Contract will be rejected and replaced at no additional cost to the City.

107.23 HANDLING MATERIALS

All materials shall be handled so their quality and fitness for the work is preserved. Aggregates shall be transported to the work in vehicles constructed to prevent loss or segregation of materials.

107.24 CITY FURNISHED MATERIALS

Material furnished by the City will be made available to the Contractor at the points specified in the Contract.

The cost of handling and placing materials after they are made available to the Contractor shall be considered as included in the Contract price for the item, and shall result in no additional cost to the City.

The Contractor will be held responsible for all material received until it is incorporated into the work and accepted.

Demurrage charges resulting from the Contractor's failure to accept the material at the designated time and point of delivery will be deducted from monies due the Contractor.

107.25 BUY AMERICA REQUIREMENTS

All manufacturing processes, including the application of a coating, for all steel and iron products permanently incorporated in the work shall have occurred in the United States of America. All manufacturing processes are defined as "processes required to change the raw ore or scrap metal into the finished, in-place steel or iron product". This requirement will not prevent a minimal use of foreign steel or iron provided the total project delivered cost of all such steel and iron which includes the cost of delivering the steel and iron to the Project, does not exceed one-tenth of one percent of the total Contract cost or \$2,500, whichever is greater.



With every steel or iron product that requires pre-inspection, pretesting, certified test results, or certificate of compliance, the Contractor shall provide a certification by each supplier, distributor, fabricator, and manufacturer that has handled the steel or iron product that every process, including the application of a coating, performed on the steel or iron product either has or has not been carried out in the United States of America. These certifications shall create a chain of custody trail that includes every supplier, distributor, fabricator, and manufacturer that handles the steel or iron product. The lack of these certifications will be justification for rejection of the steel or iron product. Upon completion of the Project, the Contractor shall certify in writing of compliance with this requirement and provide evidence of the Project delivered cost of all foreign steel or iron permanently incorporated into the Project.

107.26 TESTING OF MATERIALS

Tests and Inspections. The City will employ and pay for the services of an approved testing laboratory to perform specified services for the field testing of:

- (a) Soil Compaction Control
- (b) Cast-in-Place Concrete
- (c) Asphalt Concrete Pavement

The Contractor shall perform, or arrange for the performance, and pay all costs in connection therewith, all other tests and inspections required by the Contract documents. The Contractor shall pay for all testing laboratory services in connection with tests verifying conformance of proposed materials and installation with project requirements including, but not limited to, mix designs, riprap, gradation tests for embedment, fill and backfill materials. The City shall pay for testing laboratory services in connection with tests on materials after incorporation into the project, unless retesting of materials is necessary because of the failure of the materials to meet the Project requirements. The Contractor shall obtain the City's written acceptance of the testing laboratory before having services performed.

- 1) Requirements for Independent Testing Consultants.
 - a) Consultants shall comply with "Recommended Requirements for Independent Laboratory Qualifications", latest edition, published by the American Council of Independent Laboratories, and basic requirements of ASTM E-329, "Standards of Recommended Practice for Inspection and Testing Agencies for Concrete, Steel, and Bituminous Materials as Used in Construction", latest edition.
 - b) The Contractor shall submit to the City for prior approval, the name and address of the proposed testing laboratory with description of personnel, facilities, equipment and other qualification data, including certificate of calibration of applicable testing equipment made by an accredited calibrated agency no more than twelve (12) months prior to submittal date.
- 2) Test Reports
 - a) Testing agency shall be instructed to submit directly to the City three (3) copies of all reports of tests or inspections made, showing compliance, irregularities or deficiencies, identifying Project, date of test, location in Project, applicable specification section, applicable standard(s) for compliance, observations relating to compliance, name and signature of inspector.
- 3) Contractor Responsibilities



- a) Furnish access to the work, materials, equipment and labor required to accommodate inspections and tests when testing laboratory is retained by the City. In the event retesting of materials or recompaction is necessary because of the failure of the materials or compaction to meet the Project requirements, the cost of said retesting shall be borne by the Contractor. Cost of said retest will be deducted from the final payment amount due the Contractor, or invoiced directly to the Contractor at the City's discretion.
- 4) Reliance on Technical Data
- Without warranty or representation as to the accuracy or completeness of any information or data, Contractor may rely upon the general accuracy of the "technical data" contained in the reports, specifications and drawings. The "technical data" is identified in the work technical specifications, drawings and reports that are signed and sealed by a registered Professional Engineer, Architect or Landscape Architect in the State of Colorado. Except for the reliance on the general accuracy of the "technical data," Contractor may not rely upon or make any claim against the City with respect to:
- a) the accuracy or completeness of such reports and drawings for Contractor's purposes, including, but not limited to, any aspects of the means, methods, techniques, sequences, and procedures of construction to be employed by Contractor, and safety precautions and programs incident thereto; or
 - b) other data, interpretations, opinions, and information contained in the reports or shown or indicated in such drawings; or
 - c) any Contractor interpretation of or conclusion drawn from any "technical data" or any such other data, interpretations, opinions, or information.

107.27 UNANTICIPATED CIRCUMSTANCES

Contractor understands that this is a firm fixed price contract and so long as there are no changes in the scope of work or unanticipated circumstances as provided in subsection A-C below, Contractor must deliver the project for the agreed price. The parties agree that not every circumstance can be anticipated or known at the time this Contract was executed. Compensation for unanticipated circumstances, limited to subsections A –C, shall, at the City's sole discretion, be provided by the following method(s): (1) Unit prices previously approved; (2) allowing additional compensation on a time and materials method, not to exceed an agreed-to amount; (3) an agreed lump sum; and/or (4) the actual cost of:

- a) labor (including foreman and additional supervision, if necessary);
- b) materials necessary for incorporation into the Project;
- c) rental cost of construction plant and equipment used for work;
- d) Power and fuel required for operation of power equipment necessary to perform work;
- e) Contractor shall provide to the City physical evidence of all costs, including, but limited to, payroll, invoices, vouchers, estimates, bills, accounting records, or other relevant records. Contractor agrees that its failure to provide evidence of a claimed cost shall be a waiver of such cost(s) and the City shall be released and forever discharged from any claim of any kind whatsoever, loss, damages, request for equitable adjustment, or demand related thereto. Contractor further agrees that, at the City's discretion, a fixed fee, not to exceed 10% of the costs of work shall be added to such costs as compensation for the cost of management, insurance, benefits, bond, profit, and any other expenses.

To the extent unanticipated circumstances arise, Contractor shall follow the procedures and processes set forth herein and, if applicable, the Dispute Resolution provisions of this Contract. Contractor agrees that its failure to follow the processes set forth herein and the Dispute



Resolution process shall forever waive, release, and discharge the City from any claim of any kind whatsoever, damages, losses, lawsuits, or demands known or unknown. Additionally, the terms “detail” or “particularity” mean specificity, providing the exact basis and reason therefor with citations to the Contract or Contract Documents. Vague or ambiguous references such as “other matters” or “other costs” shall not be permitted and are not subject to any compensation method whatsoever.

Differing Site Conditions or Changed Conditions: A differing site condition or changed condition means subsurface, latent, or unknown physical site conditions that are materially different than that which is indicated in the contract and which is not ordinarily encountered and generally recognized in the work provided for in the Contract.

Contractor understands the City must be permitted the opportunity to timely investigate all differing site/changed condition matters; document conditions as they existed on the site at the time; take measurements, photographs, witness statements and the like; negotiate a compromise resolution with the Contractor and/or subcontractors; and avoid the cost, expense and delay of formal litigation.

Upon discovering a differing site condition, the Contractor shall not disturb the conditions and immediately contact the Project Manager. Within five days of discovering the condition, the Contractor shall provide written notice to the Project Manager of the condition. The written notice shall describe the condition with particularity; provide the precise material difference of the condition from the Contract, design plans, and/or other Contract Documents; describe, in detail, how the condition is not a condition that would be ordinarily encountered and generally recognized in the work provided for in the Contract; and provide a detailed explanation, including all accounting and other evidence supporting, Contractor’s losses, costs, delays, and changes in time required for performing the work. Contractor agrees that any claim, loss, damage, delay, or change in time that is not supported by evidence shall be disallowed. Contractor waives and forever releases and discharges the City from any claim of whatsoever kind, loss, damages, demand, and/or request for equitable adjustment whether known or unknown by disturbing the condition before notifying the Project Manager and by failing to provide timely detailed written notice as required herein. Any issue which is not provided for, in detail, in the written notice shall also be waived and the City shall be forever released and discharged from any claim whatsoever, loss, damage, or request for equitable adjustment, or demand arising therefrom.

After Contractor fully complies with the provisions in this section and after receiving the written notice, the Project Manager shall promptly investigate the condition and determine whether such condition materially differs from that indicated in the Contract Documents and whether it is a condition that would not ordinarily be encountered and generally recognized in the work provided for in the Contract. If the Project Manager determines the condition is a “differing site condition,” then a Change Order shall be issued describing the differing site condition and compensation method agreed to by the parties. By signing the Change Order, Contractor agrees the City shall be released and fully discharged from any claim whatsoever, loss, damage, request for equitable adjustment, or demand arising from the matters described in the Change Order. The parties shall also sign a document which describes in detail each condition and each claim, loss, damage, delay, or change in time related to that particular condition which was agreed to and fully resolved as well as any condition and each claim loss, damage, delay, or change in time related to that particular condition which is disputed.



If the Contractor disputes, disagrees with, or otherwise considers unfair any decision or ruling by the City, then Contractor shall, within 10 Calendar Days, provide the City with written notice of the dispute as set forth in the dispute section of this Contract and shall follow the dispute resolution process provided therein.

Defective or Deficient Construction Plans or Documents: A defective or deficient construction plan or document means a material error, mistake, oversight, or omission in the design plans or documents providing the specifications depicting the general and detail features of the work to be performed.

Upon discovering a defect or deficiency, the Contractor shall immediately contact the Project Manager. Within five days of initially advising the Project Manager of the defect or deficiency, the Contractor shall provide written notice to the Project Manager. The written notice shall describe the defect or deficiency with particularity explaining why it is a material defect or deficiency; provide precise detail explaining why the defect or deficiency is not something Contractor should know how to do or why the defect or deficiency is not a condition that would be ordinarily encountered and generally recognized in the work provided for in the Contract; and provide a detailed explanation, including all accounting and other evidence supporting, Contractor's losses, costs, delays, and changes in time required for performing the work. Contractor agrees that any claim, loss, damage, delay, or change in time that is not supported by evidence shall be disallowed. Contractor agrees that it shall waive and forever release and discharge the City from any claim of whatsoever kind, loss, damages, demand, and/or request for equitable adjustment whether known or unknown by failing to immediately notifying the Project Manager and by failing to provide timely detailed written notice as required herein. Any issue which is not provided for in the written notice shall also be waived and the City shall be forever released and discharged from any claim whatsoever, loss, damage, or request for equitable adjustment, or demand arising therefrom.

After Contractor fully complies with the provisions in this section and after receiving the written notice, the Project Manager shall promptly investigate the condition and determine whether such matter is a "defective or deficient design plan or document" as defined herein. If the Project Manager determines the matter is a "defective or deficient design plan or document," then a Change Order shall be issued describing the defective or deficient design plan or document, the correction and compensation method agreed to by the parties. By signing the Change Order, Contractor agrees the City shall be released and fully discharged from any claim whatsoever, loss, damage, request for equitable adjustment, or demand arising from the matters described in the change order. The parties shall also sign Form A of this Contract which describes in detail each condition and each claim, loss, damage, delay, or change in time related to that particular condition which was agreed to and fully resolved as well as any condition and each claim loss, damage, delay, or change in time related to that particular condition which is disputed.

If Contractor disputes, disagrees with, or otherwise considers unfair any decision or ruling by the City, then Contractor shall, within 10 Calendar Days, provide the City with written notice of the dispute as set forth in the Dispute Resolution section of this Contract and shall follow the dispute resolution process provided therein.

Changes in Work and Additional/Extra Work (fixed price contract): When additional information through excavation, testing, site investigation, differing site conditions, or otherwise is obtained the City shall have the right to alter, change the location, re-design, change the work, add to the



work, accelerate work, or reduce work, change the method or manner of performance, change services, and/or change materials described in the Contract (collectively “Changed Work”).

If the City changes work, then a Change Order shall be issued by the Project Manager. Contractor shall not be required to perform any Changed Work without a Change Order issued by the Project Manager. Such Changed Work shall be performed under the terms set forth in the original Contract and compensated as agreed in this section of the Contract.

If Contractor disputes any Changed Work or compensation method for such Changed Work requested by the City or set forth in a Change Order, Contractor shall, without delay, perform such work. Within 10 Calendar Days of receiving the Change Order, Contractor shall provide the City with written notice of the dispute as set forth in the Dispute Resolution section of this Contract and shall follow the dispute resolution process provided therein. Contractor further agrees that any issue not provided for, in detail, in the written notice shall also be waived and the City shall be forever released and discharged from any claim whatsoever, loss, damage, or request for equitable adjustment, or demand arising therefrom. Any matter resolved through the Dispute Resolution process shall be set forth in Form A of this Contract which describes in detail each Changed Work, including the compensation method, which was agreed to and fully resolved. By signing Form A, Contractor agrees that the City shall be released and fully discharged from any claim whatsoever, loss, damage, request for equitable adjustment, or demand arising from the matters described in Form A.

If Contractor does not dispute any Changed Work or the compensation method for such work, then Contractor shall sign the Change Order and agrees that the City shall be released and fully discharged from any claim whatsoever, loss, damage, request for equitable adjustment, or demand arising from the matters described in the Change Order.

Contractor agrees that the Project Manager shall have the authority to make minor changes in the work which do not involve additional costs and are not inconsistent with the purpose and scope of the work.

If the City finds it necessary or advisable, the City may omit, increase, or decrease any items as it may deem necessary or desirable without changing the unit prices in the proposal, provided such increase or decrease does not exceed 15% of the total monetary value of the original Contract. If material or labor involved in such change is not included in the unit prices of the Contract, but forms an inseparable part of the work to be done under this Contract, and the delay involved in asking for the bids or proposals and the letting of a new contract therefore might result in damage, injury, or impairment of the plant, work system, or other property belonging to the City, the City may in its discretion declare an emergency and require Contractor to proceed with such alterations and additions. The Contract shall not be required to perform such work or furnish extra materials without a Change Order issued by the Project Manager.

107.28 DISPUTE RESOLUTION

Mindful of the high cost of litigation, not only in dollars, but also in time and energy, the parties intend to and do hereby establish the following out-of-court alternate dispute resolution procedure to be followed in the event any dispute, claim of any kind, loss, damage, demand, request for equitable adjustment, or controversy should arise out of, or relating to this Contract or relating to any Change Order or other changes or addendums to this Contract. During the dispute resolution



procedure provided in this section, Contract shall continue to perform the work as provided for in this Contract as modified by any Change Order or Contract amendment. Nothing in this section precludes the parties from pursuing any other remedy afforded by the laws of the State of Colorado once the remedies afforded under this Contract have been complied with and exhausted.

- D. Disputes Arising from Unanticipated Circumstances: If Contractor disputes, disagrees with, or considers any decision, order, ruling, demand, request, directive, Change Order, or Contract amendment, related to the Unanticipated Circumstances provision of this Contract, and issued by the City, whether verbally or in writing, then Contractor shall:
1. Within 10 days of the City issuing any written or verbal decision, order, ruling, demand, request, directive, Change Order, or Contract amendment, Contractor shall provide written notice to the Project Manager identifying, with specific detail, each disputed matter. Any Unanticipated Circumstance dispute or matter of any kind or nature whatsoever, which Contractor does not identify in detail shall be waived and the City is released and fully discharged from any claim whatsoever, loss, damage, request for equitable adjustment, or demand arising from any matter not explicitly set forth in the written notice and described in detail;
 2. Contractor shall provide to the City all evidence of any claim of whatsoever kind, loss, damages, delay cost, or other costs, including, but not limited to payroll reports, daily logs, invoices, accounting file, receipts, email, or other relevant record or document. Any item claimed by Contractor shall be supported by verifiable evidence described herein. If Contractor requires additional time to obtain or compile such evidence, then the Contractor shall have an additional 30 days, but must identify the exact document(s) or other evidence needed, where it is maintained, and explain why it is not available. The City shall not be responsible for any delay or other damage arising from Contractor's request for additional time to obtain documents. Any item unsupported by verifiable evidence shall be waived and Contractor agrees to release and fully discharge the City from any claim of whatsoever kind, loss, damage, request for equitable adjustment, or demand related to such unsupported item.
 3. Upon receipt of Contractor's written notice, the Project Manager will investigate the disputed matter(s) and issue a written decision, ruling, order, and/or directive to Contractor. If Contractor does not dispute the Project Manager's decision, ruling, order, or directive, or a compromise has been reached, then Contractor shall sign Form A. If Contractor disputes or disagrees with the Project Manager's Ruling, then within 20 days of receiving the Project Manager's decision, ruling, order, and/or directive, Contractor must file with the City a written request for review to the City Engineer or City's Manager of the Procurement Services Division. The written request for review shall (a) state in detail the exact issue raised to the Project Manager and the issue(s) related to those matters raised to be reviewed by the City Engineer or Procurement Services Manager; (b) provide an analysis, detailing the basis, reason therefor and the how and why Contractor disagrees with the Project Manager's decision, ruling, order, or directive; and (c) attach all evidence supporting Contractor's dispute. If Contractor fails to provide a timely written request for review to the City Engineer or Procurement Services Manager, then Contractor agrees that it waives, releases, and forever discharges the City from any claim of whatsoever kind, loss, damage, request for equitable adjustment, or demand arising from or related to the Project Manager's decision, ruling, order, or directive.
 4. The City Engineer's or Procurement Services Manager's decision shall be final and conclusive for the City of Colorado Springs. If Contractor disputes, disagrees with, or



considers such decision unfair, then Contractor shall be free to pursue any other remedy afforded by the laws of the State of Colorado. If Contractor does not dispute the City Engineer's or Procurement Services Manager's decision, ruling, order, or directive or a compromise is reached, then Contractor shall sign Form A.

5. Contractor shall pay the City reasonable attorney's fees and costs associated with its failure to comply with any part of this alternate dispute process.

E. All Other Claims: If a dispute, disagreement, or controversy of any kind, other than those covered in the Unanticipated Circumstances section of this Contract, arises from or is related to the Contract, shall be resolved under the Disputes section in the Contract.

107.29 REMOVAL AND SUSPENSION FOR DEFECTIVE WORK

All work or material which has been rejected shall be remedied or removed and replaced in an acceptable manner. Additional compensation will not be allowed for such removal and replacement. Any work done beyond the lines and grades shown on the drawings, except as herein provided, will be considered as unauthorized and will not be measured or paid for. Work so done may be ordered removed at the Contractor's expense. Should the Contractor fail to comply promptly with any order of the Project Manager made under the provisions of this paragraph, the Project Manager shall have the authority to cause said work to be removed and to deduct the cost from any money due, or to become due, from the Contractor. At any time during the course of construction of this project if the provisions of the Plans, Specifications, or Contract provisions are being violated by the Contractor or his employees, the Project Manager shall have the right and authority to order all construction to cease or material to be removed, until arrangements satisfactory to the Project Manager are made by the Contractor for resumption of the work in compliance with the provisions of the Contract.

The Contractor shall promptly remove from the premises all materials and work rejected by the Project Manager as failing to meet Contract requirements, whether incorporated in the work or not, and the Contractor shall promptly replace and re-execute Contractor's own work in accordance with the Contract and without expense to the City and shall bear the expense of making good all work of other Contractors destroyed or damaged by such removal or replacement.

All removal and replacement work shall be done at the Contractor's expense. If the Contractor does not take action to remove such rejected work and materials within ten (10) days' time thereafter, the City may, upon ten (10) days written notice, sell such materials at auction or at private sale and retain the proceeds without compensation to the Contractor.

107.30 CLEANING UP AND FINAL INSPECTION

The Contractor shall at the completion of the work, remove all rubbish from and about the work and all tools, equipment, scaffolding, and surplus materials and shall leave the work clean and ready for use. If not completed by Contractor, the City may remove the rubbish and surplus materials and charge the cost to the Contractor.

All sewers, conduits, pipes, and appurtenances and all tanks, pump wells, chambers, buildings, and other structures shall be kept clean during construction and as the work or any part thereof approaches completion, the Contractor shall systematically and thoroughly clean and make any



needed repairs to them. Contractor shall furnish at Contractor's own expense, suitable tools and labor for removing all water and cleaning out all dirt, mortar, and foreign substances. Any undue leakage of water into the structures such as to make the work, in the opinion of the Project Manager, fall short of first class work, shall be promptly corrected by the Contractor at Contractor's own expense.

Cleaning and repairs shall be arranged, so far as practicable, to be completed upon finishing the construction work. Notice to begin the final cleaning, and repairing, if such is needed, will be given by the Project Manager, who at the same time will make his final inspection of the work. The Project Manager will not approve the final estimate of any portion of the work until after the final inspection is made and the work is found to be satisfactory.

107.31 CUTTING AND PATCHING

The Contractor shall do all cutting, fitting, or patching of work that may be required to make its several parts fit together or to receive the work of other contractors shown upon, or reasonably implied by the Plans and Specifications for the completed Project.

Cold or wet weather conditions that do not permit a permanent asphalt pavement replacement will require a minimum 2" bituminous pavement patch prior to opening the area to traffic as a temporary measure until the permanent asphalt pavement replacement can be installed. This item shall be incidental to any work requiring such removal of asphalt and will be considered to be included in the unit price of the related item of work.

Any cost caused by defective or ill-timed work shall be borne by the Contractor.

The Contractor shall not endanger any work by cutting, digging, or otherwise and shall not cut or alter the work of any other Contractor without the consent of the Project Manager.

107.32 FINAL TESTS

After completion of the work, the Contractor shall make any and all tests required by the Specifications or by municipal, state, or federal regulations, and where so provided in said regulations shall furnish the City with certificates of inspection by the applicable regulatory bodies. The Contractor shall also make all tests required by the National Board of Fire Underwriters for the purpose of determining insurance rates or other protection of the City or the public.

107.33 CORRECTION OF WORK AFTER FINAL PAYMENT

Neither the final payment nor any provision in the Contract Documents shall relieve the Contractor of the responsibility for negligence or faulty materials or workmanship within the extent and periods provided by law and by this Contract.

107.34 NO WAIVER OF LEGAL RIGHTS

Upon written notice that the Contractor considers all work complete, the Project Manager will make a pre-final inspection with the Contractor and will notify the Contractor in writing of incomplete or defective work revealed by the inspection. The Contractor shall promptly remedy such deficiencies.



After the Contractor has remedied all deficiencies to the satisfaction of the Project Manager and delivered all construction records including record drawings, maintenance and operating instructions, schedules, guarantees, bonds, certificates of inspection and other documents (all as required by the Contract Documents), the Contractor will be promptly issued a Certificate of Completion by the Project Manager stating that the work is acceptable.

Upon completion of the Contract, the City will make final inspection and notify the Contractor of acceptance. Final acceptance shall not preclude the City from correcting any measurement, estimate, or certificate made before or after completion of the Contract, nor from recovering from the Contractor or Surety, or both, overpayments sustained because the Contractor failed to fulfill the obligations under the Contract.

The Contractor shall be liable to the City for latent defects, fraud, or such mistakes as may amount to fraud, or as regards the City's rights under any warranty or guarantee.

For all non-federally funded projects, the following additional requirements shall apply:

- (a) All work shall be constructed in compliance with standard construction codes, and all materials and workmanship must be guaranteed for a period of two years from the date of final acceptance. If any defect in the work in violation of the foregoing warranty arises, Contractor shall, upon receipt of written notice of such defect, promptly furnish, at no cost to the City, design and engineering, labor, equipment, and materials necessary to correct such defect and cause the Work to comply fully with the foregoing warranty and Contract Documents. This obligation shall survive both final completion of and final payment for the Work. The City shall not be invoiced for any of costs of warranty work, and Contractor shall not be entitled to submit any claim for an increased fee arising therefrom. The Contractor guarantee period (two-year warranty period) will not begin until the Contract is 100 percent complete, as determined by the Project Manager. Acceptance of the 100 percent complete work shall be requested in writing by the Contractor. Any item requiring repair and/or replacement prior to expiration of the two-year warranty period shall be guaranteed for a period of one-year after the date of said correction or repair or for the remainder of the two-year warranty period, whichever is longer.
- (b) In placing orders for equipment, the Contractor shall purchase such equipment only under a written guarantee from the respective manufacturers that the equipment supplied will function satisfactorily as an integral part of the completed Project in accordance with the Plans and Specifications. Furthermore, the Contractor shall require that the manufacturer agree in writing at the time an order of equipment is placed that manufacturer will be responsible for the proper functioning of the equipment in cooperation with the Contractor, and that whenever necessary during the installation period or tuning up period following construction period, the manufacturer will supply without additional cost to the City, such superintendence and mechanical labor and any adjustments and additional parts and labor needed to make the equipment function satisfactorily, even if the same was not shown on approved shop drawings.

107.35 ACCEPTANCE

- (a) *Partial Acceptance.* If, during the performance of the project, the Contractor satisfactorily completes a unit or portion of the Project, such as a structure, an interchange, or a section of



road or pavement that can be used advantageously for traffic, the Project Manager may make final inspection of that unit. If the Project Manager finds that the unit has been satisfactorily completed in compliance with the Contract, the Contractor may be relieved of further responsibility for that unit except as otherwise provided in these general provisions. Partial acceptance shall not void or alter any of the terms of the Contract.

- (b) *Final Acceptance*. Upon notice from the Contractor of presumptive completion of the entire Project, the Project Manager will make an inspection. If the work provided for by the Contract has been satisfactorily completed, that inspection shall constitute the final inspection and the Project Manager will notify the Contractor in writing of final acceptance indicating the date on which the Project was inspected and accepted.

If the inspection discloses any unsatisfactory work, the Project Manager will give the Contractor a written list of the work needing correction. Upon correction of the work, another inspection will be made. If the work has been satisfactorily completed, the Project Manager will notify the Contractor in writing of the date of final inspection and acceptance. Final acceptance under this subsection does not waive any legal rights contained in the No Waiver of Legal Rights section of this Contract.

SECTION 108 PAYMENTS AND ACCEPTANCE OF WORK

108.00 PAYMENTS AND RETAINAGE

Payments will be made, and required retainage withheld if applicable, in accordance with this section as the work progresses at the end of each month or as soon thereafter as practicable in compliance with C.R.S. Title 24, Article 91, on statements made and approved by the Project Manager. In preparing statements, only completed work will be taken into consideration. No payment will be made for materials in storage and/or delivered to the site, unless otherwise approved by the City.

Payment for work performed by the Contractor under the Contract Documents will be made at the approved unit price or lump sum price for each of the several items as listed in the proposal and measured as hereinafter specified. Such payment shall compensate the Contractor for all costs in connection with furnishing all labor, equipment and material required and performing the operations necessary to complete the item in accordance with the Contract Documents. All incidental work essential to the completion of the Project in a workmanlike manner, and including cleanup and disposal of waste or surplus material, shall be accomplished by the Contractor without additional cost to the City. The cleanup and disposal of waste or surplus material shall be performed during construction or as soon after as is reasonably possible in order to better maintain the aesthetics and safety of the construction area. Payment will be made for the actual quantities constructed or installed, unless otherwise noted in these Contract Documents. However, any changes to plan quantity must be approved through proper Change Order procedures, said quantities being measured as specified in the Contract Documents.

- (1) If the Contract exceeds one hundred fifty thousand dollars (\$150,000.00), and is for the construction, alteration, or repair of any highway, public work, or public improvement, structure, and the Contractor has provided Performance and Payment Bonds: the City shall authorize partial progress payments of the amount due under this Contract monthly, or as soon thereafter as practicable, to the Contractor, if the Contractor is satisfactorily performing



the Contract. If the City finds that satisfactory progress is being achieved during any period for which progress is to be made, the City may authorize payment to be made in full without withholding retainage. However, if satisfactory progress has not been made, the City may retain a maximum of ten percent (10%) of the amount of the requested payment until satisfactory progress is achieved. When the work is substantially complete, the City may retain from the remaining unpaid balance that amount the City Procurement Services Manager, at the advice of the Project Manager, considers adequate for protection of the City, suppliers, subcontractors, laborers, vendors, etc., provided that such retainage shall not exceed five percent (5%) of the amount due, and shall release to the Contractor all the remaining funds associated with completed and acceptable work.

If satisfactory progress has not been made the withheld percentage of the Contract price of any such work, improvement, or construction shall be retained on an invoice-to-invoice basis and shall not be cumulative. In other words, if the Contractor is not performing satisfactorily the City will hold ten percent (10%) of what is actually due to the Contractor. For example, if the Contractor is behind schedule and has successfully completed fifty percent (50%) of the work, the City will only pay forty percent (40%) of the invoice, withholding ten percent (10%) of what is due until the Contractor gets back on schedule.

- (2) Whenever a Contractor receives payment pursuant to this section, the Contractor shall make payments to each of the subcontractors of any amount actually received which were included in the Contractor's request for payment to the City for such subcontracts. The Contractor shall make such payments within seven (7) Calendar Days of receipt of payments from the City in the same manner as the City is required to pay the Contractor under this section if the subcontractor is satisfactorily performing under the Contract with the Contractor. The subcontractor shall pay all suppliers, sub-subcontractors, laborers, and any other persons who provide goods, materials, labor, or equipment to the subcontractor any amounts actually received which were included in the subcontractor's request for payment to the Contractor for such persons, in the same manner set forth in this subsection (2) regarding payments by the Contractor to the subcontractor. If the subcontractor fails to make such payments in the required manner, the subcontractor shall pay those suppliers, sub-subcontractors, and laborers interest in the same manner set forth in this subsection (2) regarding payments by the Contractor to the subcontractor.

At the time a subcontractor submits a request for payment to the Contractor, the subcontractor shall also submit to the Contractor a list of the subcontractor's suppliers, sub-subcontractors and laborers. The Contractor shall be relieved of the requirements of this subsection (2) regarding payment in seven (7) days and interest payment until the subcontractor submits such list. If the Contractor fails to make timely payments to the subcontractor as required by this section, the Contractor shall pay the subcontractor interest as specified by Contract or at the rate of fifteen percent (15%) per annum, whichever is higher, on the amount of the payment which was not made in a timely manner. The interest shall accrue for the period from the required payment date to the date on which payment is made. Nothing in this subsection (2) shall be construed to affect the retention provisions of any Contract.

- (3) If the Contractor is not progressing in accordance with the Project Schedule or not performing quality work in accordance with the specifications, the City Procurement Services Manager, at the advice of the Project Manager may withholding retainage up to and including ten percent (10%) of the total contract amount.



108.01 PAYMENTS WITHHELD PRIOR TO FINAL ACCEPTANCE OF WORK

The City may withhold or nullify the whole or part of any certificate of payment to such extent as may be necessary to protect it from loss caused by:

- (a) Defective work not remedied.
- (b) Claims filed or reasonable evidence indicating probable filing of claims by other parties against the Contractor.
- (c) Failure of the Contractor to make payments properly to subcontractors or for material or labor.
- (d) Damage to another contractor.

When the above grounds are removed, payment will be made for amounts withheld because of them.

108.02 ACCEPTANCE OF FINAL PAYMENT

If the work is finally accepted by Project Manager under the terms and conditions of the Contract the entire balance found by the Project Manager to be due the Contractor, including the retained percentage, less any retention based on; (1) the Project Manager's estimate of the fair value of the claims against the Contractor; and (2) the cost of completing the incomplete or unsatisfactory items of work with specified amounts for each incomplete or defective item of work; and (3) retentions required by law, shall be due and payable to the Contractor. The date of completion is the date as specified in the Certificate of Completion issued by the Project Manager.

Upon completion of the work under the Contract and before the Contractor will receive or be paid for the Project Manager's final statement, the City Procurement Services Division shall post a notice in the Colorado Springs Gazette that the City has accepted such work as completed according to the Plans and Specifications and rules set forth in the Contract; that the Contractor is entitled to final settlement; that after the date specified in the Notice, the City will pay the full balance due under the Contract; and that persons having claims for labor or material furnished the Contractor must present their claim to the City Procurement Services Division prior to the date specified for such payment. Nothing herein shall be construed as relieving the Contractor and the Sureties on the Contractor's bonds from any claim or claims for work or labor done or materials or supplies furnished in the execution of the Contract.

The making and acceptance of the final payment shall constitute a waiver of all claims by the Contractor against the City.

If, after the work has been substantially completed, full completion thereof is materially delayed through no fault of the Contractor, and the Project Manager so certifies, the City may, upon Certificate of Completion by the Project Manager, and without terminating the Contract, make payment of the balance due for that portion of the work fully completed and accepted. Such payment shall be made under the terms and conditions governing final payment, and acceptance of the payment shall constitute a waiver of all claims by the Contractor but acceptance of the work shall not constitute a waiver of City claims against the Contractor.



Advertising for Final Payment and processing of the Final Pay Request shall not take place until after the Contractor has submitted Sales and Use Tax Forms to the City and said forms have been reviewed and approved by the City Sales Tax Office.



SCHEDULE C – SCOPE OF WORK

The project consists of construction of pond improvements including multiple low flow channels, mass grading and revegetation plan, revised outlet structure, riprap, Truegrid Pavers, granite sand access roads, aesthetic improvements, planting and/or seeding and restoration of areas disturbed during construction. The work is being completed to modify an existing flood control pond within the project site.

A location approximately 0.6 miles from the project site has been designated for long-term stockpiling of excess cut material. This area is called “Sand Creek Stockpile area.” The stockpiled material will be used for future projects including Stand Creek Detention Pond No. 2 Restoration, Pond 2 to Barnes Road Sand Creek Restoration, and Coleman Park.

Construction is to begin as soon as possible and the Contractor will have 300 calendar days to complete all construction activities.



SCHEDULE D – CITY STORMWATER MANAGEMENT PLAN (CSWMP)

Will follow this page.

CITY STORMWATER MANAGEMENT PLAN (CSWMP)

SAND CREEK DETENTION POND NO. 2 RESTORATION

Prepared for:

City of Colorado Springs Stormwater Enterprise
30 S Nevada Ave
Suite 403
Colorado Springs, CO 80903



2480 West 26th Avenue, Suite B225
Denver, CO 80211

Prepared by:



August 2024

Merrick Project Number 65420975

Table of Contents

CAPITAL PROJECT GEC PLAN (CONSULTANT) SIGNATURE PAGE	1
ENGINEER’S STATEMENT	1
CONTRACTOR’S STATEMENT	1
CITY PROJECT MANAGER’S STATEMENT	1
City of Colorado Springs Grading and Erosion Control Review	2
STATE STORMWATER DISCHARGE PERMIT REQUIREMENTS	3
STORMWATER MANAGEMENT PLAN OBJECTIVES	3
State Permit Applicant	4
CSWMP Terms	5
Contractor Required Items	5
CONSTRUCTION STORMWATER MANAGEMENT PLAN	6
NAME, ADDRESS, PHONE NUMBER:.....	6
PERMITTEE	6
OWNER/DEVELOPER	6
ENGINEER	6
SUBDIVISION/PROJECT NAME:	6
ADJACENT AREAS.....	6
EXISTING SITE CONDITIONS	8
PROPOSED IMPROVEMENTS	9
RECEIVING WATERS	11
CONSTRUCTION PHASING	11
SOIL BORINGS/TESTS AND GROUNDWATER	11
OWNER INSPECTIONS.....	12
GEC ADMINISTRATOR CERTIFICATION	12
COLORADO DEPARTMENT OF PUBLIC HEALTH AND ENVIRONMENT CONSTRUCTION GENERAL PERMIT REQUIREMENTS	13
CSWMP/GEC ADMINISTRATOR	13
MATERIALS HANDLING AND SPILL PREVENTION.....	13
WASTE MANAGEMENT AND DISPOSAL.....	14
CCM IMPLEMENTATION	14
Installation of Initial CCMs	14
Site Clearing	14
Site Grading	14
Landscaping	15
Final Stabilization	15
STRUCTURAL PRACTICES	15
Vehicle Tracking Control (VTC)	15
Stabilized Staging Area (SSA)	15
Concrete Washout Area (CWA)	15
CULVERT INLET PROTECTION (cip)	15
PORTABLE TOILET (PT)	15
construction fence (CF)	15
Erosion Control Blanket (ECB) and Turf Reinforced Mat (TRM)	15
Seeding and Mulching (SM)	15
Temporary Outlet Protection (TOP)	15
Rock Check Dam	15
SEDIMENT CONTROL LOGS (scl)	15
Silt Fence (SF)	16
Stockpile Protection (SP)	16
NON-STRUCTURAL PRACTICES	16



TIMING SCHEDULE.....	18
FINAL STABILIZATION.....	18
CCM OPERATION AND MAINTENANCE.....	19
INSPECTION AND MAINTENANCE.....	19
Minimum Inspection Schedule	19
GROUNDWATER AND STORMWATER DEWATERING	20
REFERENCES	21



Figures

Figure 1. Project Vicinity Map	7
Figure 2. Project Location Map	7

Tables

Table 1. Identification of Potential Pollutant Sources.	17
--	----

Appendices

- APPENDIX A– CONSTRUCTION DRAWINGS
- APPENDIX B– GEOTECHNICAL EVALUATION REPORT
- APPENDIX C – GEC ADMINISTRATOR CERTIFICATION
- APPENDIX D – HYDRAULIC CALCULATIONS



CAPITAL PROJECT GEC PLAN (CONSULTANT) SIGNATURE PAGE

ENGINEER'S STATEMENT

This CSWMP was prepared under my direction and supervision and is correct to the best of my knowledge and belief. If such work is performed in accordance with the CSWMP, the work will not become a hazard to life and limb, endanger property, or adversely affect the safety, use, or stability of a public way, drainage channel, or other property.

Printed Name: Walter Pennington Date: 9/04/2024

Phone Number: 720-330-3210



CONTRACTOR'S STATEMENT

I will comply with the requirements of the Grading and Erosion Control Plan/CSWMP including Construction Control Measure inspection requirements and final stabilization requirements. I acknowledge the responsibility to determine whether the construction activities on these plans require Colorado Discharge Permit System (CDPS) permitting for stormwater discharges associated with construction activity.

Name of Contractor: _____

Authorized Signature: _____ Date: _____

Title: _____ Phone Number: _____

Address: _____

Email Address: _____

CITY PROJECT MANAGER'S STATEMENT

I hereby certify that the drainage, grading, and erosion control for Sand Creek Detention Pond No. 2 shall be constructed according to the design presented in this CSWMP. I further understand that field changes must be reviewed by the SWENT Review Engineer to ensure conformance with the original design intent. I am employed by and perform engineering services solely for the City of Colorado Springs, and therefore am exempt from Colorado Revised Statute Title 12, Article 25, Part 1 according to § 12-25-103(1), C.R.S.

Name of City Project Manager: Beau Thompson, PE

Signature:  Date: 9-19-24



City of Colorado Springs Grading and Erosion Control Review

This CSWMP is filed in accordance with City Code. This plan is reviewed in accordance with the Stormwater Construction Manual; latest revisions.

_____ Date: _____

For the SWENT Manager

Notes: _____



STATE STORMWATER DISCHARGE PERMIT REQUIREMENTS

At least ten days prior to the anticipated start of construction activities (i.e. the initial disturbance of soils associated with clearing, grading, excavation activities, installation of structural Best Management Practices, or other activities), for projects that will disturb one (1.0) acre or more, the owner or operator of the construction activity must submit an application as provided by the Colorado Department of Public Health and Environment, Water Quality Control Division (Division). This form may be reproduced and is also available from the Division's web site. Applications received by the Division are processed and a permit certification and other relevant materials will be sent to the attention of the legally responsible person. The application contains a certification of completion of a City Storm Water Management Plan (CSWMP). Do not include a copy of the City Stormwater Management Plan, unless requested by the Division.

For information or application materials contact:

Colorado Department of Public Health and Environment
Water Quality Control Division
WQCD-P-B2
4300 Cherry Creek Drive South Denver, Colorado 80246-1530
<https://www.colorado.gov/pacific/cdphe/wq-construction-permits>

Electronic Application - CDPHE website:

<https://www.colorado.gov/pacific/cdphe/WQ%20permits%20construction%20electronic%20application>

STORMWATER MANAGEMENT PLAN OBJECTIVES

The objective of the City Stormwater Management Plan (CSWMP) is "to identify possible pollutant sources that may contribute pollutants to stormwater and identify Construction Control Measures (CCMs) that, when implemented, will reduce or eliminate any possible water quality impacts. The CSWMP must be completed and implemented at the time the project breaks ground and revised as construction proceeds, to accurately reflect the conditions and practices at the site (CDPHE *Stormwater Management Plan Preparation Guidance*)". A general schedule or phasing of CCMs will be determined by construction schedule and ground disturbances necessitating required erosion control methods/CCMs. The CSWMP shall be implemented until expiration or inactivation of permit coverage. Evaluations of and modifications to this plan may be necessary during the length of the construction project until the site is finally stabilized.

CSWMP Plan Availability: A copy of the Stormwater Discharge Permit from the State of Colorado, CSWMP Report, CSWMP Site Map, CSWMP Notes and Details, and inspection reports shall be kept on site by the GEC Administrator at all times, as to be available for use by the operator/GEC Administrator and to be available for inspection by federal, state and local agencies. If an office location is not available at the site, the CSWMP must be managed so that it is available at the site when construction activities are occurring (for example: by keeping the CSWMP in the superintendent's vehicle). The permittee shall retain copies of the CSWMP and all reports required by the Permit and records of all data used to complete the Permit application for three (3) years minimum after expiration or inactivation of permit coverage, unless the community requires a longer period.

This CSWMP should be viewed as a "living document" that is continuously being reviewed and modified as a part of the overall process of evaluating and managing stormwater quality issues at the site. The GEC Administrator shall amend the CSWMP when there is a change in design, construction, operation or maintenance of the site which would require the implementation of new or revised CCMs or if the CSWMP proves to be ineffective in achieving the



general objectives of controlling pollutants in stormwater discharges associated with construction activity or when CCMs are no longer necessary and are removed. If the GEC Administrator feels that modifications to the CCMs shown on the CSWMP are necessary to provide for a more effective plan, the process will include: 1) Evaluate pollutant sources, 2) Select CCMs, 3) Document CCMs, 4) Implement CCMs.

CSWMP revisions must be made prior to changes in the site conditions, except for "Responsive CSWMP Changes" as follows:

- CSWMP revision must be made immediately after changes are made in the field to address CCM installation and/or implementation issues; or
- CSWMP revisions must be made as soon as practicable, but in no case more than 72 hours, after change(s) in CCM installation and/or implementation occur at the site that require development of materials to modify the CSWMP
 - A notation must be included in the CSWMP prior to the site change(s) that includes the time and date of the change(s) in the field, and identification of the CCM(s) removed or added and the location(s) of the CCM(s). Modifications to the CSWMP shall be submitted to the City within seven days.

A City of Colorado Springs Grading Permit is required along with a Colorado Discharge Permit System (CPS), Stormwater Discharge Associated with Construction Activities Permit from the Colorado Department of Public Health and Environment for this project. The general conditions associated with the permits must be followed through the duration of the land disturbing activities at the site. For additional details or more specific information on the CDPS permit, consult the CDPS General Permit No. COR-030000. City Grading Permit: Signoff and acceptance of the Grading, Erosion and Stormwater Quality Control Plan by the City constitutes a Grading Permit authorizing the approved land disturbance and implementation of the approved erosion and stormwater quality control measures.

STATE PERMIT APPLICANT

The State Permit applicant (also referred to as the Permittee) must be a legal entity that meets the definition of the owner and/or operator of the construction site, in order for this application to legally cover the activities occurring at the site. The applicant must have day-to-day supervision and control over activities at the site and implementation of the CSWMP. Although it is acceptable for the applicant to meet this requirement through the actions of a contractor, as discussed in the examples below, the applicant remains liable for violations resulting from the actions of their contractor and/or subcontractors. Examples of acceptable applicants include:

Owner or Developer - An owner or developer who is operating as the site manager or otherwise has supervision and control over the site, either directly or through a contract with an entity such as those listed below.

General Contractor or Subcontractor - A contractor with contractual responsibility and operational control (including CSWMP implementation) to address the impacts construction activities may have on stormwater quality,

Other Designated Agents/Contractors - Other agents, such as a consultant acting as construction manager under contract with the owner or developer, with contractual responsibility and operational control (including CSWMP implementation) to address the impacts construction activities may have on stormwater quality,

Refer to the CDPHE, Stormwater Management Plan Preparation Guidance for additional information.

The Permittee shall be legally responsible for compliance with the State Permit.



CSWMP TERMS

Construction Control Measures (CCMs): CCMs encompass a wide range of erosion and sediment control practices, both structural and non-structural in nature, that are intended to reduce or eliminate any possible water quality impacts from stormwater leaving a construction site. The individual CCMs appropriate for a particular construction site are largely dependent of the types of potential pollutant sources present, the nature of the construction activity, and specific-site conditions.

Nonstructural CCMs such as preserving natural vegetation, preventive maintenance and spill response procedures, schedules of activities, prohibition of specific practices, education, and other management practices are mainly operational or managerial techniques.

Structural CCMs include treatment processes and practices ranging from diversion structures and silt fences to retention ponds and inlet protection.

Construction Start Date: This is the day when ground disturbing activities are expected to begin, including grubbing, stockpiling, excavating, demolition, and grading activities.

Disturbance Area Determination: Aside from clearing, grading and excavation activities, disturbed areas also include areas receiving overburden (e.g., stockpiles), demolition areas, and areas with heavy equipment/vehicle traffic and storage that disturb existing *vegetative cover*.

Final Stabilization Date: In terms of permit coverage, this is when the site is finally stabilized. This means that all ground surface disturbing activities at the site have been completed, and all disturbed areas have been either built on, paved, or a uniform vegetative cover has been established with an individual plant density of at least 70 percent of pre-disturbance levels (refer to Final Stabilization Section). Noxious weeds will not be counted towards the necessary plant density. Permit coverage must be maintained until the site has reached Final Stabilization. Even if only one part of the project is being done, the estimated final stabilization date must be for the overall project. If permit coverage is still required once your part is completed, the permit certification may be transferred or reassigned to a new responsible entity(s).

CSWMP Drawings: Also known as the CSWMP Site Map.

CONTRACTOR REQUIRED ITEMS

The Contractor shall include and/or provide the following items prior to beginning land disturbing activities:

- Add the GEC Administrator and Alternate with phone numbers to this plan.
- Construction Dates - Verify the construction dates indicated in this report. Update as necessary to reflect the planned schedule.
- Material Handling and Spill Prevention procedures - See Section 3.5. Review and modify as necessary.



CONSTRUCTION STORMWATER MANAGEMENT PLAN

NAME, ADDRESS, PHONE NUMBER:

PERMITTEE

Name: _____

Address: _____

Primary Contact: _____

Phone: _____

OWNER/DEVELOPER

City of Colorado Springs
30 S Nevada Ave, Suite 401
Colorado Springs, CO 80903
Adam Copper, PE
(719) 385-5436

ENGINEER

Merrick & Company
2480 W 26th Ave, Suite 225B
Denver, CO 80211
Walter Pennington, PE, CFM
(720) 330-3210

SUBDIVISION/PROJECT NAME:

Sand Creek Detention Pond No. 2 Restoration

ADJACENT AREAS

The project site is located generally between North Carefree Circle and Barnes Road, approximately 0.3 miles north-northeast of the intersection of North Carefree Circle and Tutt Boulevard in the City of Colorado Springs in El Paso County, Colorado. The site lies within the NW1/4 and NE1/4 of Section 30 Township-13-South Range-65-West of the Sixth Principal Meridian in El Paso County, Colorado. Sand Creek flows from the north to the south through the site, draining into Fountain Creek approximately nine miles downstream of the project reach. The project site is located in unplatted parcels (No. 5330200040 and 5330100018), which are owned by the City of Colorado Springs. Adjacent properties are owned by Greenways Investments LLC, Sky Sox Stadium Inc, Freeman & Kallaher Colorado Property LLC, 4089 Tutt LLC, Tutt Commercial Center LLC, Salvation Army, and Delegation Group LLC. Adjacent land is a mix of residential, commercial and parks. Property ownership information is included on Sheet 4 Existing Conditions in the 95% Construction Drawings included in Appendix A of this document. Two easements provide access to the site. A drainage easement provides access west of the project from Tutt Blvd and a public access easement (known as Tract D) provides access through the Greenways development on the east side of the project. The project site is shown on the Vicinity and Location Maps (Figure 1 and Figure 2). The total area of disturbance will be 22.1 acres.



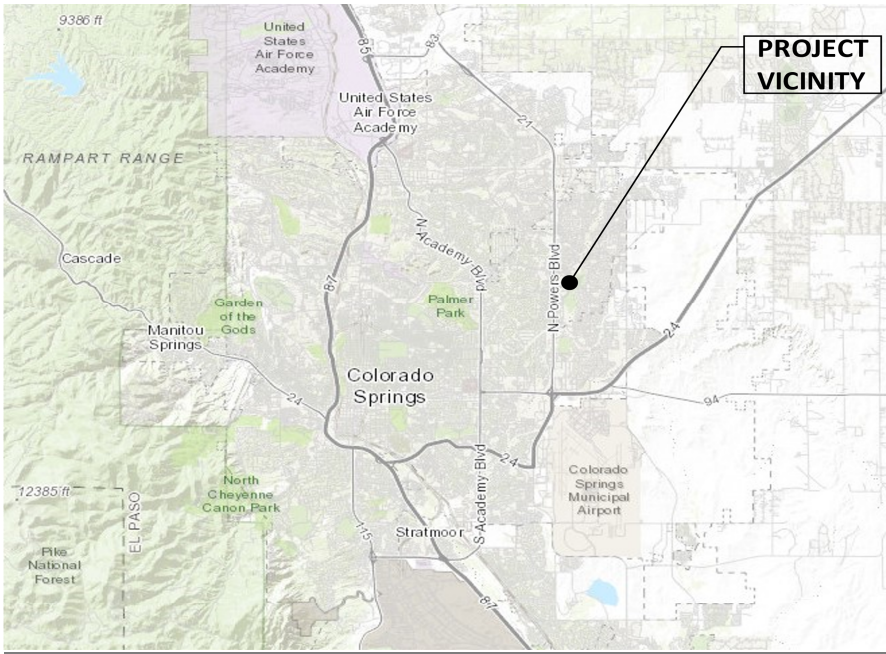

Figure 1. Project Vicinity Map



NTS

Figure 2. Project Location Map



EXISTING SITE CONDITIONS

Pond 2 was originally constructed in 2009 along with soil cement drop structures located 300 feet upstream of the pond. The original project was called “Sand Creek Detention Basin No. 2” and was designed by Kiowa Engineering Corporation in 2006. Sand Creek enters the pond from the north and passes over a soil cement flow spreader prior to entering the pond. The flow spreader was designed to have a physical drop of 4.4 feet. Due to sedimentation, the current physical drop at the flow spreader is about 1 foot. In addition to the flow spreader, approximately 850-feet of soil cement lining with a buried toe was constructed around approximately two-thirds of the pond as shown in the drawings. Some of the soil cement lining is used for a maintenance access path. The total height of the lining, including the buried toe, varies from 10 feet at the flow spreader to 13 feet outside the main channel.

In addition to flood control, the pond was intended to capture sediment and was designed without a low flow channel. Although a low flow channel has formed in the eastern portion of the pond, it is not continuous and significant sedimentation, ponding, and dense vegetation has occurred in the pond bottom. The average slope from the flow spreader to the outlet structure is 0.8%. The open nature of the pond has resulted in dense vegetation of primarily cattails. The channel upstream of the pond is a highly eroded trapezoid channel with steep banks. The channel downstream of the pond contains several grade control structures.

The pond outlet has two stages. Low flows are controlled by five (5) 18-inch reinforced concrete pipes that drain the pond under a soil cement access road. High flows are controlled by three (3) 8-foot-high by 12-foot-wide concrete box culverts (CBC) downstream of the soil cement access road. The pond embankment is approximately 14.2 feet in height and classified as a Class III (Low-Hazard) Dam by the State Engineer’s Office.

Due to deeply incised outfall channels between the Security Service Field parking lot and the pond, as well as development on the east side of the pond, significant maintenance has not been feasible for the past three to four years. As a result, captured sediment has not been removed.

Barnes Outfall Water Quality Pond is expected to be constructed by others before the beginning of Pond 2 restoration. Barnes Pond will have receive flow from 2 existing storm outfalls near Security Service Field and Barnes Pond will discharge into Pond 2. Barnes Outfall Water Quality Pond Final Drainage report, approved March 2024, was used in the design of Pond 2.

Most of the Pond 2 bottom is comprised of wetlands. Approximately 13.1 acres of wetlands are present in the vicinity of Pond 2. These wetlands are dominated by narrowleaf and broadleaf cattail, with the margins of the wetland community hosting a slightly more diverse wetland palette including rushes (*Juncus* spp.) bulrushes (*Schoenoplectus* spp.), sedges (*Carex* spp.), and various facultative or wetter herbaceous species. Introduced/non-native species that are dominant in portions of the wetland communities includes reed canary grass (*Phalaris arundinacea*), and redtop (*Agrostis gigantea*). Noxious and/or nuisance vegetation present in the wetland communities include Colorado Noxious Weed List A hairy willowherb (*Epilobium hirsutum*), List B Canada thistle (*Cirsium arvense*) and common teasel (*Dipsacus fullonum*), and List C species common mullein (*Verbascum thapsus*) and field bindweed (*Convolvulus arvensis*).

The Study Area is vegetated with trees and shrubs in the riparian to upland zones. Dominant species present include coyote willow (*Salix exigua*), Siberian elm (*Ulmus pumila*), eastern plains cottonwood (*Populus deltoides*), and Russian olive (*Elaeagnus angustifolia*). Based on visual inspection, the project area has 95% vegetation coverage.

Weedy herbaceous species are present in the uplands, such as cheatgrass (*Bromus tectorum*), kochia (*Kochia scoparia*), diffuse knapweed (*Centaurea diffusa*), and yellow sweetclover (*Melilotus officinalis*). Other dominant species observed in the uplands include smooth brome (*Bromus inermis*), western ragweed (*Ambrosia psilostachya*), blue grama (*Bouteloua gracilis*), purple three-awn (*Aristida purpurea*), orchard grass (*Dactylis glomerata*), side-oats grama (*Bouteloua curtipendula*), and intermediate wheatgrass (*Thinopyrum intermedium*).



PROPOSED IMPROVEMENTS

MAIN POND IMPROVEMENTS

The purpose of the proposed improvements is to pass active sediment through the pond, prevent unintended ponding, and to promote vegetative diversity. To achieve this, a proposed channel slope of 0.3% with two (2) 1-foot riffle drops located approximately 400 feet apart is recommended. The slope of the riffle drops will be 2.0%. The channel design is generally a trapezoidal section with a 30-foot-wide bottom, side slopes of 4:1, and a depth of 2 feet. The channel bottom will be lined with void-permeated riprap at the riffle locations. Channel banks will be lined with soil riprap to the bank full depth (2-feet).

Except where flat grades are proposed to establish wetlands and enhance vegetation, the pond bottom is proposed to drain toward the low flow channels with a minimum of slope of 1%.

Pond embankments will be graded to slopes of 4:1 (H:V) or flatter where possible. Above Tutt Blvd. Outfall, the existing embankment is nearly 2:1 and confined to the west by private property. A retaining wall will be necessary to allow the construction of a maintenance path in this location.

Two modifications to the existing upstream drop structure are proposed. A low flow notch will be cut 1 foot into the sill downstream of the pool. Though this may result in a small increase to the hydraulic drop over the structure, it will decrease the channel slope between the pool and the proposed crest of the downstream flow spreader from 1% to approximately 0.65%. A cutoff wall is also proposed at the upstream end of the drop structure to reduce seepage and the likelihood of undermining.

The proposed pond outlet structure is designed to convey bankfull flows (200 cfs) without detention. Flows will be conveyed from the proposed Sand Creek Channel through a 25-foot-wide by 2.5-foot-high orifice into a concrete channel of similar dimensions. The concrete channel will lead directly into two of the three existing 12-foot-wide by 8-foot-high culverts with a 2-foot-high concrete curb. At flows greater than bankfull, detention will begin. As flows increase, the orifice will detain flow until the water surface elevation reaches 6508.0. At that elevation, flow will be conveyed over a multi-tiered weir structure that is sized to pass the 100-year design flow defined by the Sand Creek DBPS (2,500 cfs). The weir begins to overtop above the 10-year storm event. Flow will fall freely over the weir into the concrete basin below before being conveyed through the three large CBCs. The orifice and weir control the flow for flows up to 2,500 cfs. The maximum anticipated 100-year water surface elevation is 6511.0. At this elevation, the existing Pond 2 dam embankment will not overtop.

Maintenance access will be provided into the proposed outlet structure through five removable stop logs and an approximately 12% ramp.

FEMA regulatory 100-year flow, 4,500 cfs, is controlled by the three CBCs. The regulatory 100-year flow is not detained.

The existing dam embankment will not be modified.

The total disturbed area for the project is 22 acres.

There are no allowable non-stormwater discharges at the site, including no discharges under applicable low-risk discharge guidance policy.

TUTT BLVD. OUTFALL

The Tutt Blvd. Outfall is a 6-foot-high by 10-foot-wide box culvert that enters the pond from the west. The existing outfall consists of a riprap apron confined by concrete wingwalls and a soil cement access road. The access road is 1 foot above the riprap apron to provide a settling basin, however, there is no drainage path for the flow that enters the basin until it overtops the access road and the outfall experiences significant ponding in the existing condition. According to the construction drawings for the outfall, the 100-year design flow for the culvert is 780 cfs, however



the Sand Creek DBPS identifies the 100-yr flow for the contributing sub-basin to be 111 cfs. There are no known upstream treatment facilities.

Per City guidance, no forebay will be provided at the Tutt Blvd. Outfall. The culvert will outfall directly onto a riprap apron to protect against erosive forces.

The Tutt Outfall Channel design is generally a trapezoidal section at an average of 0.41% slope with a 20-foot-wide bottom, side slopes of 4:1, and a depth of 1 foot. The channel bottom will be lined with void-permeated riprap to the bank full depth (1 foot).

The confluence of the Tutt Outfall Channel with Sand Creek Channel will occur upstream of the proposed outlet structure.

SPRINGS RANCH OUTFALL

The Springs Ranch Outfall consists of three (3) 30-inch PVC culverts and is located in the northeast corner of the pond. These culverts pass flow below the existing gravel access road. The Sand Creek DBPS identified the 100-yr flow for the contributing sub-basin to be 132 cfs. The channel was sized for this flow with 1 foot of freeboard.

The Springs Ranch Channel design is generally a trapezoidal section at an average of 2.5% slope with a 18-foot-wide bottom, side slopes of 2.4:1, and a depth of 2.5 feet. The channel will be lined with grouted boulders.

BARNES WATER QUALITY POND OUTFALL

A 54" RCP outfall with a headwall, wingwalls, and concrete apron leaving the Barnes Water Quality Pond is to be constructed by others before Sand Creek Detention Pond No. 2 Restoration project. A channel sized for the Barnes Water Quality Pond 2-year discharge (33cfs) will convey flow from the 54-inch RCP to the Sand Creek Main Channel. Outlet protection for the 54-inch RCP will be a low-tailwater basin. Calculations for these design components can be found in Appendix D.

BARNES WATER QUALITY POND EMERGENCY SPILLWAY

An emergency spillway for Barnes Pond is to be constructed as part of the Barnes Pond project, then altered during the restoration of Pond No. 2. As constructed in the Barnes Pond project, the upper portion of the spillway will be lined with articulated concrete mat, the middle portion with existing soil cement lining, and the lower portion with type L soil riprap. Pond No. 2 restoration will lower the bottom of the pond, therefore the grades of the lower portion of the spillway will need to be altered.

Analysis was done to show that the type L soil riprap on the lower portion of the emergency spillway will be stable when the emergency spillway is activated with and without a high flow event occurring in Pond No 2. To show the riprap is stable when the emergency spillway conveys the Barnes Pond 100-year inflow and no tailwater is present in Pond No. 2, Colorado Springs DCM Chapter 13 Section 5.12 and equation 13-9 was used. HEC-RAS 2D modeling was used to show how flows interact when the emergency spillway conveys the Barnes Pond 100-year inflow and Pond No. 2 experiences a 25-year flow event. Table 7-3 of the Urban Drainage Design Manual (HEC-22) was used to choose the recurrence interval of the concurrent flow event in Pond No. 2.

The type L riprap lines the embankment of Pond No. 2 at the location of the emergency spillway and extends 15-feet onto the bottom of Pond No. 2. The stability of the sloped portion of the riprap was analyzed using Colorado Springs DCM Chapter 13 Section 5.12 and equation 13-9 with localized unit discharge results from the 2D model. It is not appropriate to use the same approach to evaluate the stability of the riprap on the bottom of Pond No. 2 because detention in Pond No. 2 causes much greater depth and lower velocity than anticipated in Section 5.12. Instead, USDCM Volume 1 Chapter 8 Section 8.1.1 "Mild Slope Conditions" was used with localized velocity results from the 2D model. The analysis of the sloped and flat portions of the spillway riprap show type L will be stable when the spillway conveys the 100-year Barnes inflow and there is a 25-year event in Sand Creek. Calculations and HEC-RAS 2D model results can be found in Appendix D.



RECEIVING WATERS

The receiving waters include the downstream reach of Sand Creek, which then flows into Fountain Creek (approximately 9 miles downstream of the project site).

CONSTRUCTION PHASING

Initial and final phasing of construction control measures are shown in the Grading and Erosion Control (GEC) Plans. CCMs include, but may not be limited to, construction fence, silt fence, vehicle tracking control, stabilized staging area, materials storage area, concrete washout area, portable toilet, erosion control blanket, seeding and mulching, rock check dams, sediment control logs, silt fence, rock sock, stockpile protection and inlet/outlet protection. Construction is planned to commence in October 2024, with an anticipated completion date of February 2025. It is anticipated that construction will begin with site preparation including clearing and grubbing, removal of structures and obstructions, and installation of initial erosion control measures. Surface water control will be established by routing the flow to one side of the pond while half of the pond is constructed, and then to the completed side of the pond while the remainder of the pond is constructed. Construction dewatering may be required and will be conducted in accordance with the construction dewatering permit for the project groundwater removed from work areas will be treated prior to discharging into receiving waters. A temporary stream crossing may be required to traverse from the western side of the pond from the construction staging area to the eastern side of the pond during construction. This temporary stream crossing may be removed and relocated during construction as required to provide access to the full site. Rough grading will be completed first, followed by placement of riprap and bedding channel toe protection. Fine grading and riprap will be placed after completion of the structures. Initial erosion control measures will be removed as they are no longer required, and final measures, seeding and blanketing, will be installed as the contractor demobilizes from the site. The construction staging area will be returned to pre-construction conditions prior to final acceptance.

SOIL BORINGS/TESTS AND GROUNDWATER

A geotechnical investigation has been completed and a copy of the report is included in Appendix B.

VIVID Engineering Group explored the subsurface conditions by drilling, logging, and sampling three (3) exploratory borings located near the pond outlet structure, just inside the southern embankment of the pond, and in the middle of the pond (as close to the proposed channel as was safe to bore). The borings were drilled to depths ranging between approximately 24.5 to 29.5 feet below the existing ground surface and borings terminated within the claystone/sandstone bedrock unit. Groundwater was encountered at each boring location at a depth of 3 feet to 8 feet. The general profile encountered in the borings consisted of the following soil types.

Existing Fill

Existing fill was encountered at the ground surface in borings near the existing pond outlet (Borings B-1 and B-2) and extended to approximately 8 feet below the existing ground surface. The fill material consisted of silty sand, was grayish brown in color and hard to very hard based on drilling observations and field penetration resistance testing (blow counts). VIVID believes the fill material may be cement-treated soil that was placed during the construction of the southern embankment.

Alluvium

Native soils comprised predominately of silty to clayey sand, poorly graded sand with silt and gravel as well as thin layers of elastic silt with sand were encountered at the ground surface or below the unit described above and extended to depths of approximately 9 to 14 feet below the ground surface. The materials were generally grayish brown, light brown, and light gray in color, moist to wet, and field penetration testing (blow counts) indicated the relative density of the sand soils was generally loose to medium dense and the silt soils were stiff.

Bedrock

Weathered to comparatively unweathered bedrock of the Dawson Formation was encountered at 12 feet below existing grade in Boring B-1, 14 feet below existing grade in Boring B-2, and 9 feet below existing grade in Boring B-3.



The bedrock extended to the maximum depth explored in each of these borings. The bedrock consisted predominantly of interbedded sandstone and claystone. The sandstone and claystone bedrock were generally gray, grayish brown and yellowish brown, moist to wet, and hard to very hard. The boring logs in the geotechnical investigation report can be reviewed for more detailed descriptions of the subsurface conditions at each of the boring locations explored.

OWNER INSPECTIONS

The GEC Administrator shall, at a minimum, make a thorough inspection at least once every 14 calendar days. Also, post-storm event inspections must be conducted within 24 hours following the end of any precipitation or snowmelt event that causes surface erosion. Provided the timing is appropriate, the post-storm inspections may be used to fulfill the 14-day routine inspection requirement. Alternatively, the GEC Administrator may choose to perform self-inspections every 7 calendar days and forego post-storm event inspections. The self-inspection schedule must be identified in the GEC Administrator's most recent self-inspection. A more frequent inspection schedule than the minimum described may be necessary to ensure that control measures continue to operate as needed to comply with the GEC Plan. Site conditions such as steep grades and close proximity to a state water are reasons for increasing the frequency of self-inspections.

The GEC Administrator shall submit documentation of the self-inspections by uploading the document to the City's electronic permitting management system. Completed self-inspection forms must be submitted electronically within 5 business days of the self-inspection. The self-inspections must also be available either physically or electronically at the construction site at all times throughout the duration of the project. GEC Inspectors will review self-inspections during City Compliance Inspections. The use of a third-party inspection program does not remove this requirement. Additionally, the use of a third-party inspection program does not relieve the Permittee of the requirement to comply with all compliance inspections. For sites or portions of sites where construction activities have been completed and final stabilization measures installed but final stabilization has not yet been achieved, the GEC Administrator shall make a thorough inspection of their stormwater control measures at least once every month. Post-storm event inspections must continue to be conducted within 24 hours following the end of any precipitation or snowmelt event that causes surface erosion. The GEC Plan must be amended to indicate those areas where construction activities have been completed but final stabilization has not yet been achieved that will be inspected once a month. When site conditions make the schedule required in this section impractical, the permittee may petition the City to grant an alternate inspection schedule. The alternative inspection schedule may not be implemented prior to written approval by the City and incorporation into the CSWMP.

GEC ADMINISTRATOR CERTIFICATION

Included in Appendix C a copy of the Grading and Erosion Control Administrator's certification of completion for the City of Colorado Springs GEC-Training Class or approved equivalent.



COLORADO DEPARTMENT OF PUBLIC HEALTH AND ENVIRONMENT CONSTRUCTION GENERAL PERMIT REQUIREMENTS

GEC ADMINISTRATOR

The Permittee shall designate the GEC Administrator, who can be the same as the Contractor. The GEC Administrator is typically the Contractor or his/her designated representative and is responsible for developing, implementing, maintaining and revising the CSWMP. The GEC Administrator is the contact person with the City and State for all matter pertaining to the CSWMP. The GEC Administrator is the person responsible for the CSWMP accuracy, completeness and implementation. Therefore, the GEC Administrator should be a person with authority to adequately manage and direct day to day stormwater quality management activities at the site. The GEC Administrator shall have the authority to act on behalf of the Permittee(s) to ensure the site remains in compliance with the CDPS Stormwater Discharge Associated with Construction Activities Permit and the City's Grading Permit. An Alternate GEC Administrator who is able to serve in the same capacity as the GEC Administrator shall also be selected.

The GEC Administrator shall be present at the project site a majority of the time and (along with the Alternate GEC Administrator) shall provide the City with a 24-hour emergency contact number.

If the GEC Administrator or Alternate changes for any reason, it shall be noted/redlined on this Plan. The City shall be notified in writing of any change.

GEC Administrator: _____

Phone: _____

Alternate GEC Administrator: _____

Phone: _____

MATERIALS HANDLING AND SPILL PREVENTION

The GEC Administrator will inspect daily to ensure proper use and disposal of materials on-site including solvents, fertilizers, chemicals, waste materials and equipment maintenance or fueling procedures. All materials stored on-site will be stored in a neat and orderly manner in the original containers with the original manufacturer's label, and if possible under a roof or other enclosure to prevent contact with stormwater. Chemicals should be stored within berms or other secondary containment devices to prevent leaks and spills from contacting stormwater runoff. Before disposing of the container, all of a product will be used up whenever possible and manufacturer's recommendations for proper disposal will be followed according to state and local regulations.

Material and equipment necessary for spill cleanup will be kept in the material storage area on-site. Manufacturer's recommendations for spill cleanup will be posted and site personnel will be made aware of the procedures along with the location of the information and cleanup supplies.

The contractor shall have spill prevention and response procedures that include the following:

- a) Notification procedures to be used in the event of an accident. At the very least, the GEC Administrator should be notified. Depending on the nature of the spill and the material involved, the Colorado Department



of Public Health and Environment (24-hour spill reporting line - 877-518-5608), downstream water users or other agencies may also need to be notified.

- b) Instructions for clean-up procedures and identification of spill kit location(s).
- c) Provisions for absorbents to be made available for use in fuel areas and for containers to be available for used absorbents
- d) Procedures for properly washing out concrete truck chutes and other equipment in a manner and location so that the materials and wash water cannot discharge from the site and never into a storm drain system or stream.

WASTE MANAGEMENT AND DISPOSAL

A concrete washout area is specified on the CSWMP. Concrete wash water shall not be discharged to state waters, to storm sewer systems or from the site as surface runoff. The washout area shall be an approved portable concrete washout system or a shallow excavation with a small perimeter berm to isolate concrete truck washout operations. At the end of construction, all concrete shall be removed from the site and disposed of at an approved waste site. Signs shall be placed at the washout to clearly indicate the concrete washout area to operators of concrete trucks and pump rigs. Refer to the standard detail for requirements.

All construction site waste both liquid and solid must be contained in approved waste containers and disposed of off-site according to state and local regulations. Portable sanitary facilities shall be provided at the site throughout the construction phase and must comply with state and local sanitary or septic system.

CCM IMPLEMENTATION

The GEC Administrator shall update the CCM Implementation if necessary to meet and/or address the Contractor's schedule. The CSWMP shall be updated as necessary to reflect the CCMs installed.

INSTALLATION OF INITIAL CCMs

Prior to any construction activities, erosion control facilities shall be installed. Minimal clearing and grubbing may be necessary prior to installing the initial erosion control features. Stabilization of cleared or grubbed areas to be completed the same day if possible. The "initial" CCMs include, but may not be limited to, construction fence, silt fence, vehicle tracking control, stabilized staging area, materials storage area, concrete washout area, and inlet/outlet protection. Designate areas for construction trailer (if used), trash container, portable toilets, vehicle and equipment parking and material storage. If these areas are not indicated on the plan, the contractor must "red line" the plan with the locations. Provide a confined area for maintenance and fueling of equipment from which runoff will be contained and filtered. CCM / Erosion Control facility waste shall be disposed of properly.

SITE CLEARING

The measures included in the previous sequence shall be maintained and continued. The removed cleared and grubbed items, soil, storm sewer pipe, and concrete rubble shall be stored or disposed of properly. If a soil stockpile area is needed, the area shall be protected as shown in the Details and the stockpile area shall be redlined onto the plan. Existing vegetation to remain shall be protected. Wind erosion shall be controlled on the site by sprinkling and other appropriate means.

SITE GRADING

The measures included in the previous sequence shall be maintained and continued. The area of disturbance within these areas shall be minimized especially along the toe of slopes that may be subject to precipitation event flows. The contractor shall not leave any equipment in the bottom of the drainageways, especially in times when precipitation is expected or when the contractor is not on site. Dewatering is expected. A CDPHE construction dewatering permit is required prior to performing the dewatering activities. Materials associated with the channel construction shall be stored in the designated areas delineated on the plan. If an area is not delineated on the plan, the contractor shall "red line" the plan to show the location. Material waste from the construction shall be disposed of properly. Solvents, paints, and chemicals shall be stored and disposed properly.



LANDSCAPING

The measures included in the previous sequence shall be maintained and continued, unless the work requiring the measure is completed. Seeding, mulching, and blanketing shall be installed. Avoid excess watering and placing fertilizers and chemicals.

FINAL STABILIZATION

The necessary erosion control measures included in the previous sequence shall continue until Final Stabilization is reached. Refer to the Final Stabilization section for requirements.

STRUCTURAL PRACTICES

A list of the Structural CCMs for erosion and sediment control implemented on the site to minimize erosion and sediment are as follows: refer to the GEC Plan for Installation and Maintenance requirements for each structural CCM and the location of the CCMs.

VEHICLE TRACKING CONTROL (VTC)

Consists of a rock pad that is intended to help strip mud from tires prior to vehicles leaving the construction site. Installed at the entrance/exit point to the site.

STABILIZED STAGING AREA (SSA)

Consists of stripping topsoil and spreading a layer of granular material in the area to be used for a trailer, parking, storage, unloading, and loading. The stabilized staging area shall include a material storage area.

CONCRETE WASHOUT AREA (CWA)

An approved concrete washout system. See Erosion and Sediment Control Details.

CULVERT INLET PROTECTION (CIP)

Permeable sediment barrier installed upstream of a flared end section entrance to a culvert or storm sewer.

PORTABLE TOILET (PT)

Used to mitigate the possibility of contamination to adjacent waters. Remove prior to end of construction.

CONSTRUCTION FENCE (CF)

Construction fence restricts site access to designate entrances and exits, delineates construction site boundaries, and keeps construction out of sensitive areas.

EROSION CONTROL BLANKET (ECB)

Areas shall be protected with an erosion control blanket or turf reinforced mat as indicated on the CSWMP drawings.

INLET PROTECTION

Consists of a permeable sediment barrier installed around a storm inlet.

SEEDING AND MULCHING (SM)

Temporary seeding and mulching can be used to stabilize disturbed areas that will be inactive for an extended period of time. Permanent seeding should be used to stabilize areas at final grade that will not otherwise be stabilized.

TEMPORARY OUTLET PROTECTION (TOP)

A temporary riprap apron to reduce erosion immediately downstream of the outlets.

ROCK CHECK DAM

A temporary grade control structure to limit erosion due to stormwater flows during construction. Also, serves as a sediment barrier.

ROCK SOCK

Consists of gravel that has been wrapped by wire mesh or a geotextile to form an elongated cylindrical filter.



SEDIMENT CONTROL LOGS (SCL)

A temporary sediment barrier consisting of a linear roll of natural materials such as straw, coconut, excelsior or coconut fiber.

SILT FENCE (SF)

A temporary sediment barrier constructed of woven fabric stretched across supporting posts.

STOCKPILE PROTECTION (SP)

An area for excess excavated material and stockpiles for imported materials. Slopes shall not be greater than 2:1 if stabilized, and otherwise shall not be greater than 3:1.

Minimal clearing and grubbing may be necessary prior to installing the initial erosion control features.

No clearing, grading, excavation, filling or other land disturbing activities shall be permitted until signoff and acceptance of the Grading, Erosion and Stormwater Quality Control Plan is received from the City.

Once signoff and acceptance are received, the approved erosion and sediment control measures must be installed before land-disturbing activities are initiated so that no adverse effect of site alteration will impact surrounding property.

NON-STRUCTURAL PRACTICES

Seeding and mulching in areas that will not be hard surfaced. Minimize the amount of existing vegetation to be removed during construction, leaving native vegetation in place when possible. Only the existing vegetation that is specified or requiring removal shall be disturbed or removed. If possible, leave existing ground cover in place or remove just prior to grading to minimize the length of soil exposure.



IDENTIFICATION OF POTENTIAL POLLUTANT SOURCES

Could it contribute?	Potential Pollutant Sources	CCM Implemented to Control Source
Yes	All disturbed and stored soils	Silt fence, seeding, temporary outlet protection, rock check dams, sediment control log, erosion control blanket
Yes	Vehicle tracking of sediments	Vehicle tracking control
No	Management of contaminated soils	
Yes	Loading and unloading operations	Stabilized staging area, materials storage area, silt fence, vehicle tracking control
Yes	Outdoor storage activities (building materials, fertilizers, chemicals, etc.)	Stabilized staging area, materials storage area, silt fence, sediment control log
Yes	Vehicle equipment maintenance and fueling	Stabilized staging area, materials storage area, silt fence
Yes	Significant dust or particulate generating processes	Controlled by sprinkling with water and other appropriate means
Yes	Routine maintenance activities involving fertilizers, pesticides, detergents, fuels, solvents, oils, etc.	Use as recommended by manufacturer and in areas specified, silt fence
Yes	Off-site waste management practices (waste piles, liquid wastes, dumpsters, etc.)	Stabilized staging area, silt fence, non-structural CCMs
Yes	Concrete truck/equipment washing, including the concrete truck chute and associated fixtures and equipment	Concrete washout area, stabilized staging area, vehicle tracking control, silt fence
No	Dedicated asphalt and concrete batch plants	
Yes	Non-industrial waste sources such as worker trash and portable toilets	Stabilized staging area, construction fence, non-structural CCMs
Yes	Other areas or procedures where potential spills can occur	Non-structural CCMs, construction fence

Table 1. Identification of Potential Pollutant Sources.



TIMING SCHEDULE

The anticipated start date to construction is in the Fall of 2023. **Construction sequence and timing for major construction activities will be added to this section upon selection of Contractor.**

FINAL STABILIZATION

As stated in the City of Colorado Springs Stormwater Enterprise Stormwater Construction Manual (Chapter 6, Section 2.6), "Final stabilization is reached when all ground surface disturbing activities at the site have been completed and uniform vegetative cover has been established with an individual plant density of at least 70 percent of pre-disturbance levels, or equivalent permanent, physical erosion reduction methods have been employed." Noxious weeds will not be counted towards the necessary plant density.

When vegetation is used to achieve final stabilization, the 70% vegetation requirement applies to a uniform plant density, which means that all areas of the site that rely on a vegetative cover to achieve stabilization must be uniformly vegetated. The contractor will be responsible for providing the documentation to make this comparison to the City and the State of Colorado, Water Quality Control Division. The stormwater permit allows the permittee to use alternatives to vegetation to achieve final stabilization. All alternatives to vegetation must meet specific criteria to be considered equivalent to vegetation, specifically: stabilization must be permanent, all disturbed areas must be stabilized, and alternatives must follow good practices as described in City of Colorado Springs Drainage Criteria Manual.

Temporary seeding for the project site shall include seeding and mulching. For the application methods, soil preparation and seeding and mulching requirements, refer to CSWMP Drawings. All slopes of three-to-one (3:1) or steeper must be covered with an erosion control blanket.

Management of storm water after completion of construction will be accomplished by utilizing the practices listed below.

1. Upon completion of construction, the site shall be inspected to ensure that all equipment, waste materials and debris have been removed.
2. The site will be inspected to make certain that all graded surfaces have been landscaped or seeded with an appropriate ground cover.
3. All silt fence, rock socks, etc. and all other control practices and measures that are to remain after completion of construction will be inspected to ensure their proper functioning.
4. The contractor shall remove erosion control measures that are not required to remain.

After all construction activities are completed on the site, but final stabilization has not been achieved, the contractor shall make a thorough inspection of the stormwater management system at least once every month.

The contractor shall be responsible for maintaining the CCMs and stormwater controls in good working order and shall also be responsible for the costs incurred until such time as final stabilization is reached. Once final stabilization has been achieved the contractor shall be responsible for removal of the erosion control measures.

Should any of the erosion control facilities (CCMs) become in disrepair prior to the establishment of the native or natural erosion control measures, the Contractor is responsible for the cost of such maintenance. The Contractor is also responsible for the clean-up of offsite areas affected by any sediment that may leave the site. Control of erosion from areas disturbed by channel or storm sewer construction will be the responsibility of the respective contractor. All erosion control measures shown on the plan shall be installed and maintained in accordance with Best Management Practices.



Inactivation of permit coverage: Coverage under the Stormwater Construction Permit may be inactivated by the permittee when the site has attained final stabilization, all temporary erosion and sediment control measures have been removed, and all components of the CSWMP are complete.

CCM OPERATION AND MAINTENANCE

The GEC Administrator is responsible for operation and maintenance of construction CCMs. The GEC Administrator will inspect the site per inspection and monitoring protocol outlined above and will make any necessary repairs to construction CCMs immediately after a defect or other need for repair is discovered. The project site and the adjacent streets impacted by the construction shall be kept neat, clean, and free of debris. The erosion control measures and facilities will be maintained in good working order until final stabilization. Any items that are not functioning properly or are inadequate will be promptly repaired or upgraded. Records of inspections must be kept and be available for review by the State of Colorado Water Quality Control Division or the City.

INSPECTION AND MAINTENANCE

MINIMUM INSPECTION SCHEDULE

1. Frequency: Contractor should inspect and document Construction CCM's as outlined in the Owner Inspections section, above.
2. Consult State Permit No. COR-030000 for alternate inspection requirements at temporarily idle sites, at completed sites, or for winter conditions.
3. Refer to the Standard Details for the maintenance procedures associated with each CCM.
4. Inspection Procedures: The inspection must include observation of:
 - a. The construction site perimeter and discharge points (including discharges into a storm sewer system).
 - b. All disturbed areas.
 - c. Areas used for material/waste storage that are exposed to precipitation.
 - d. Other areas determined to have a significant potential for stormwater pollution, such as concrete washout locations, or locations where vehicles enter or leave the site.
 - e. Erosion and sediment control measures identified in the CSWMP; and any other structural CCMs that may require maintenance, such as secondary containment around fuel tanks, or the condition of spill response kits.

The inspection must determine if there is evidence of, or the potential for, pollutants entering the drainage system. CCMs should be reviewed to determine if they still meet the design and operational criteria in the CSWMP, and if they continue to adequately control pollutants at the site. Any CCMs not operating in accordance with the CSWMP must be addressed as soon as possible, immediately in most cases, to minimize the discharge of pollutants, and the CSWMP must be updated as described.

5. Record Keeping and Documenting Inspections: Keeping accurate and complete records serves several functions. First, keeping records of spills, leaks, inspections, etc. is a requirement of the State Stormwater Construction Permit; therefore, enforcement action, including fines, could result if records are not adequate. Second, by keeping accurate and detailed records, you will have documentation of events which could prove invaluable should complications arise concerning the permit, lawsuits, etc.
6. Inspection Checklist/Report: The Permittee must document inspection results and maintain a record of the results for a period of 3 years following expiration or inactivation of permit coverage. These records must be made available to CDPHE, the City or EPA upon request. The GEC Administrator should record the inspection



results on a site-specific standardized inspection report or City Inspection Checklist to be maintained and kept on the construction site. An example template for the inspection report format is included in Appendix. The GEC Administrator should develop a site-specific inspection report that itemizes the selected Construction CCM's for their site. At a minimum the following information from each inspection should be recorded on the site-specific report:

- a. Date of inspection.
- b. Name and title of inspector.
- c. Location(s) of discharges of sediment or other pollutants from the site.
- d. Location(s) of CCMs that need to be maintained.
- e. Location(s) of CCMs that failed to operate as designed or proved inadequate for a particular location.
- f. Location(s) where additional CCMs are needed that were not in place at the time of inspection.
- g. Deviations from the minimum inspection schedule as provided in the permit.
- h. Descriptions of corrective actions for any item above, date(s) of corrective actions taken, and measures taken to prevent future violations, including requisite changes to the CSWMP, as necessary.

After adequate corrective action(s) has been taken, or where a report does not identify any incidents requiring corrective actions, the report shall contain a signed statement indicating the site is in compliance with the permit to the best of the signer's knowledge and belief.

7. Inspection Checklists/Reports to City: Completed Inspection Checklists will be submitted electronically to the assigned City Engineering inspector within 5 business days of the inspection. The inspections checklists must also be kept on-site.

GROUNDWATER AND STORMWATER DEWATERING

Groundwater dewatering is anticipated on the site for the channel construction. Locations and practices to be implemented to control stormwater pollution from excavations, etc. will be noted by the contractor. A separate CDPHE construction discharge (dewatering) permit will be required for groundwater dewatering and shall be obtained by the GEC Administrator. Construction dewatering water cannot be discharged to surface water or to storm sewer systems without separate permit coverage. The discharge of Construction Dewatering water to the ground, under specific conditions, may be allowed by the Stormwater Construction Permit when appropriate CCMs are implemented. Refer to USDCM Volume III (MHFD) for City acceptable means of dewatering.



REFERENCES

CDPHE. *Stormwater Discharges Associated with Construction Activity. Stormwater Management Plan Preparation Guidance*. April 2011.

City of Colorado Springs. *Drainage Criteria Manual Volumes 1 and 2*. May 2014.

City of Colorado Springs. *Stormwater Construction Manual*. December 2020.

Mile High Flood District. *Urban Storm Drainage Criteria Manual Volume 3*. Rev. October 2019

Vivid Engineering Group. *Geotechnical Evaluation Report, Sand Creek*, April 2022.



APPENDIX A- Construction Drawings



THE CITY OF COLORADO SPRINGS, COLORADO, IS AN INSTRUMENTALITY OF THE STATE OF COLORADO. THE CITY ENGINEER HAS REVIEWED THESE PLANS AND SPECIFICATIONS AND HAS FOUND THEM TO BE IN ACCORDANCE WITH THE CITY CHARTER AND ORDINANCES. THE CITY ENGINEER'S REVIEW IS LIMITED TO THE TECHNICAL ASPECTS OF THE PROJECT AND DOES NOT CONSTITUTE A GUARANTEE OF THE ACCURACY OF THE INFORMATION PROVIDED HEREON. THE CITY ENGINEER'S REVIEW IS LIMITED TO THE TECHNICAL ASPECTS OF THE PROJECT AND DOES NOT CONSTITUTE A GUARANTEE OF THE ACCURACY OF THE INFORMATION PROVIDED HEREON.

APPROVED BY: _____

CITY OF COLORADO SPRINGS _____ DATE
ENGINEERING DIVISION

CITY OF COLORADO SPRINGS _____ DATE
STORMWATER ENTERPRISE

COLORADO SPRINGS _____ DATE
PARKS AND RECREATION DEPARTMENT

COLORADO SPRINGS UTILITIES _____ DATE
WATER RESOURCES - WATER

COLORADO SPRINGS UTILITIES _____ DATE
WATER RESOURCES - WASTEWATER

COLORADO SPRINGS UTILITIES _____ DATE
ELECTRIC DEPARTMENT

COLORADO SPRINGS UTILITIES _____ DATE
GAS DEPARTMENT

"I HEREBY CERTIFY THAT THE DRAINAGE IMPROVEMENTS FOR SAND CREEK DETENTION POND NO. 2 SHALL BE CONSTRUCTED ACCORDING TO THE DESIGN PRESENTED IN THESE PLANS. I FURTHER UNDERSTAND THAT FIELD CHANGES MUST BE REVIEWED BY THE CITY REVIEW ENGINEER TO ENSURE CONFORMANCE WITH THE ORIGINAL DESIGN INTENT. I AM EMPLOYED BY AND PERFORM ENGINEERING SERVICES SOLELY FOR THE CITY OF COLORADO SPRINGS, AND THEREFORE AM EXEMPT FOR COLORADO REVISED STATUTE TITLE 12, ARTICLE 25, PART 1 ACCORDING TO § 12-25-103(1) C.R.S.

NAME OF CITY PROJECT MANAGER _____
AUTHORIZED SIGNATURE _____ DATE _____

CAUTION - NOTICE TO CONTRACTOR
THE CONTRACTOR IS SPECIFICALLY CAUTIONED THAT THE LOCATION AND/OR ELEVATION OF EXISTING UTILITIES SHOWN ON THESE PLANS IS BASED ON RECORDS OF THE VARIOUS UTILITY COMPANIES, AND WHERE POSSIBLE, MEASUREMENTS TAKEN IN THE FIELD.

THE INFORMATION IS NOT TO BE RELIED UPON AS BEING EXACT OR COMPLETE. THE CONTRACTOR MUST CALL THE APPROPRIATE UTILITY COMPANIES AT LEAST 72 HOURS BEFORE ANY EXCAVATION TO REQUEST EXACT FIELD LOCATION OF UTILITIES. IT SHALL BE THE RESPONSIBILITY OF THE CONTRACTOR TO RELOCATE ALL EXISTING UTILITIES WHICH CONFLICT WITH THE PROPOSED IMPROVEMENTS SHOWN ON THE PLANS.

SAND CREEK DETENTION POND NO. 2 RESTORATION FINAL DESIGN

PREPARED FOR:
**CITY OF COLORADO SPRINGS, COLORADO
STORMWATER ENTERPRISE
PROJECT NO. R010097**

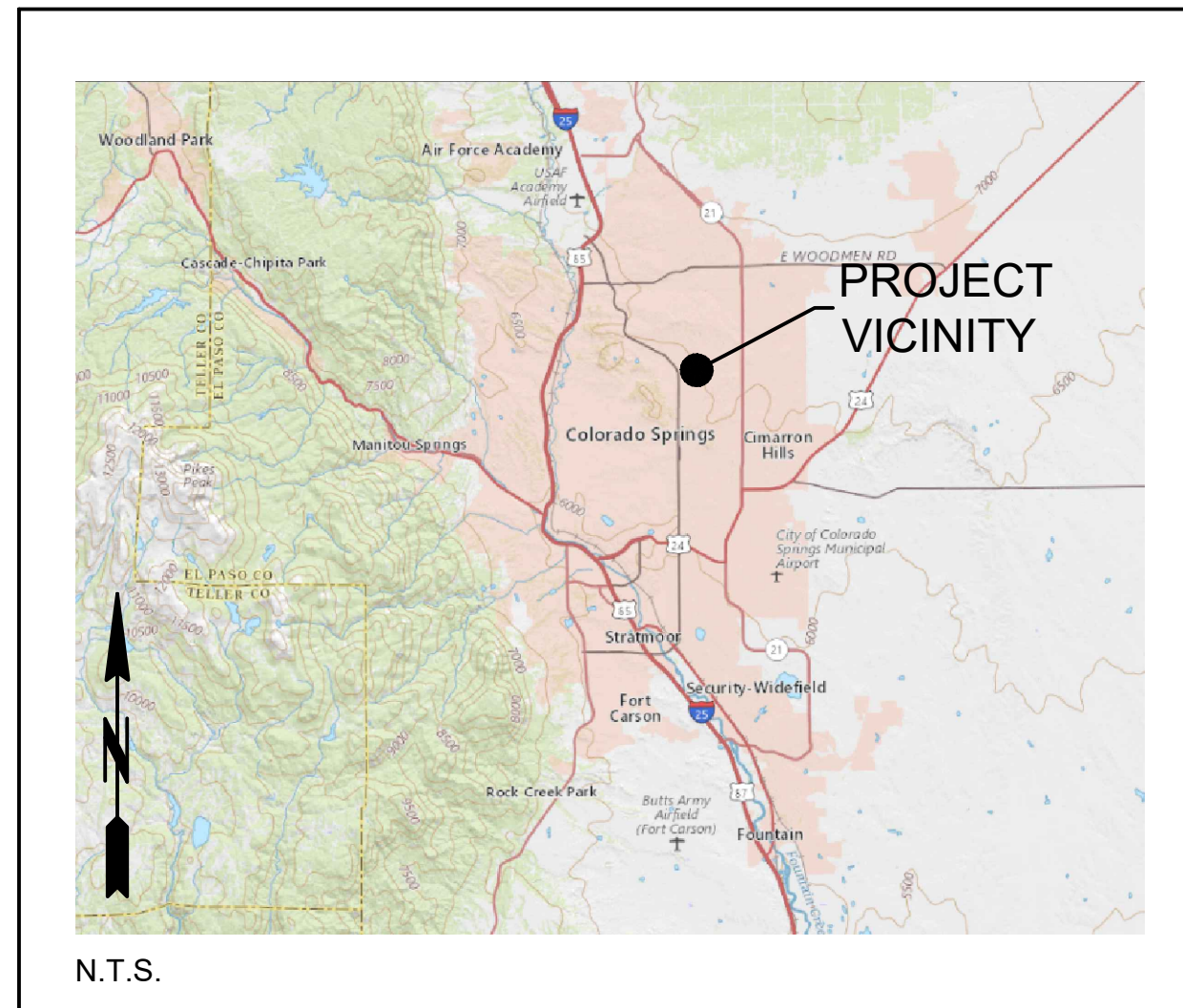

VICINITY MAP

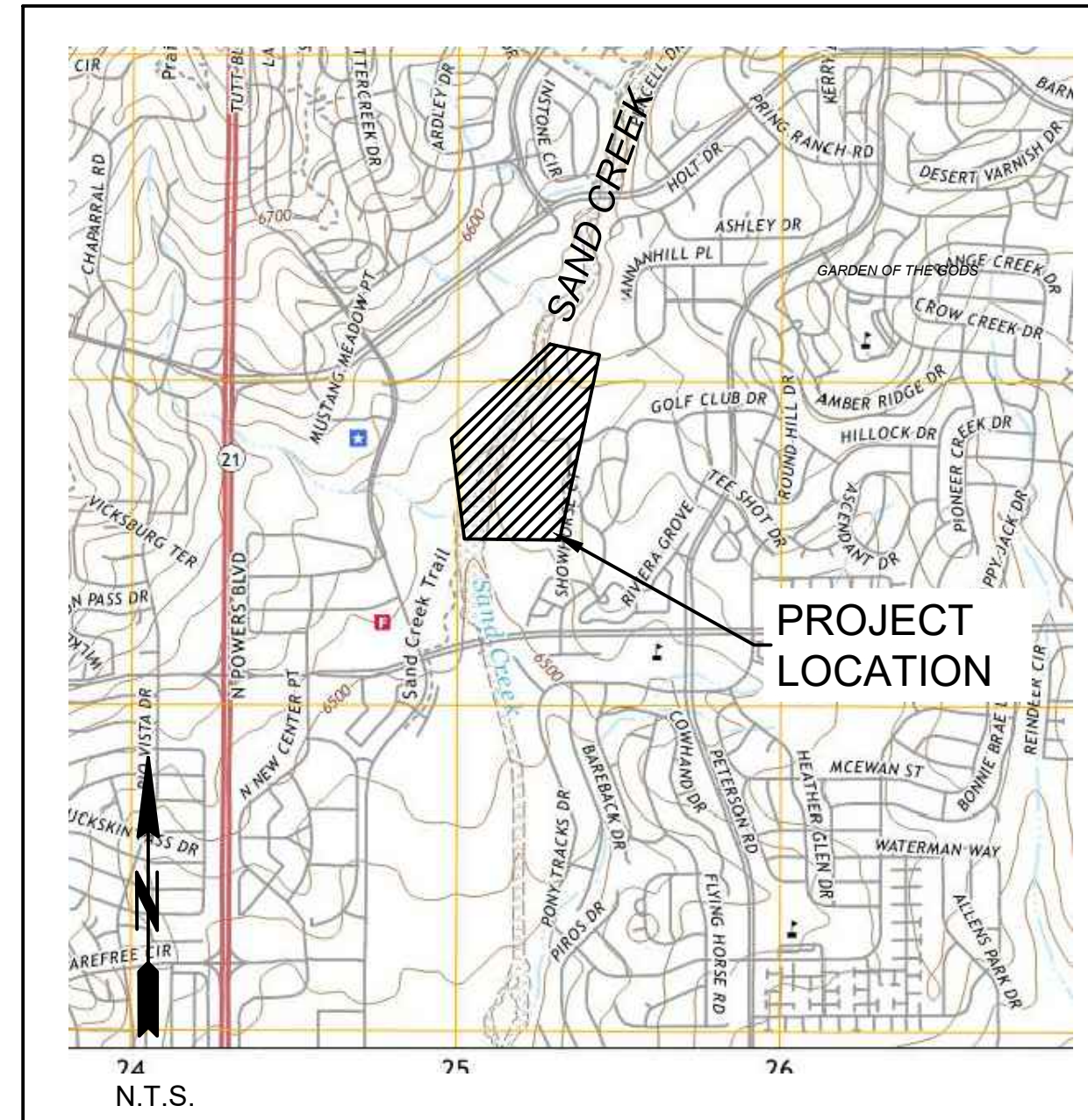

LOCATION MAP

SHEET INDEX		
DWG	SHEET TITLE	SHEET
ID-101	COVER SHEET	1
ID-202	GENERAL NOTES AND LEGEND	2
C-101	SUBSURFACE UTILITY ENGINEERING PLAN	3
C-102	PROJECT CONTROLS (SOUTH)	4
C-103	PROJECT CONTROLS (NORTH)	5
C-201	EXISTING CONDITIONS, PROPERTY OWNERSHIP, AND DEMOLITION PLAN	6
C-301	CONSTRUCTION ACCESS, STAGING, AND GENERAL TRAFFIC CONTROL	7
C-401	OVERALL GRADING PLAN AND KEY MAP	8
C-402	GRADING PLAN (SOUTH)	9
C-403	GRADING PLAN (NORTH)	10
C-404	POND SECTIONS	11
C-405	POND SECTIONS	12
C-501	SAND CREEK CHANNEL PLAN AND PROFILE 0+00 TO 7+50	13
C-502	SAND CREEK CHANNEL PLAN AND PROFILE 7+50 TO 15+45	14
C-503	TUTT OUTFALL PLAN AND PROFILE	15
C-504	SPRINGS RANCH WETLAND CHANNEL PLAN AND PROFILE	16
C-505	SPRINGS RANCH PLAN AND PROFILE	17
C-506	BARNES WQ POND OUTFALL PIPE AND CHANNEL PLAN AND PROFILE	18
C-507	POND PERIMETER ACCESS ROAD PROFILE	19
C-508	OUTLET STRUCTURE AND TUTT OUTFALL ACCESS ROAD PROFILES	20
C-601	POND OUTLET STRUCTURE	21
C-602	RIPRAP DETAILS	22
C-603	CIVIL DETAILS	23
C-604	CIVIL DETAILS	24
L-100	SEEDING AND WETLAND PLUGS PLAN	25
L-101	PLANTING PLAN	26
L-102	PLANTING PLAN	27
L-201	PLANTING DETAILS	28
L-301	OUTFALL STRUCTURE AESTHETIC DETAILS	29
L-302	OUTFALL STRUCTURE AESTHETIC DETAILS	30
L-303	OUTFALL STRUCTURE AESTHETIC DETAILS	31
L-304	TUTT OUTFALL AND RETAININGWALL AESTHETIC DETAILS	32
S-100	LEGEND, ABBREVIATIONS, AND GENERAL NOTES SHEET 1	33
S-101	LEGEND, ABBREVIATIONS, AND GENERAL NOTES SHEET 2	34
S-102	POND 2 OUTLET ISOMETRIC VIEW	35
S-103	POND 2 OUTLET OUTLINE PLAN	36
S-104	POND 2 OUTLET SECTIONS	37
S-105	POND 2 OUTLET REINFORCEMENT PLAN	38
S-106	POND 2 OUTLET REINFORCEMENT SECTIONS	39
S-107	POND 2 OUTLET REINFORCEMENT SECTIONS	40
S-108	POND 2 OUTLET REINFORCEMENT SECTIONS	41
S-109	POND 2 OUTLET DOWEL ANCHOR PLAN AND DETAILS	42
S-110	POND 2 OUTLET UNDER DRAIN PLAN AND DETAILS	43
S-111	POND 2 OUTLET CONCRETE STANDARD DETAILS	44
S-112	TUTT WALL ISOMETRIC	45
S-113	TUTT WALL OUTLINE PLAN AND ELEVATIONS	46
S-114	TUTT WALL REINFORCEMENT PLAN AND SECTION	47
S-115	TUTT WALL REINFORCEMENT PLAN AND SECTION	48
S-116	TUTT WALL REINFORCEMENT PLAN AND SECTION	49
S-117	TUTT WALL REINFORCEMENT PLAN AND SECTION	50
S-118	POND 2 OUTLET & TUTT RETAINING WALL STEEL HANDRAIL DETAILS	51

ENGINEER'S STATEMENT:
THIS PERMANENT CONTROL MEASURE (PCM) PLAN WAS PREPARED UNDER MY DIRECTION AND SUPERVISION, WAS DESIGNED IN ACCORDANCE WITH THE CITY OF COLORADO SPRINGS DRAINAGE CRITERIA MANUAL (MAY 2014), AND IS CORRECT TO THE BEST OF MY KNOWLEDGE AND BELIEF. I ACCEPT RESPONSIBILITY FOR ANY LIABILITY CAUSED BY ANY NEGLIGENT ACTS, ERROR OR OMISSIONS ON MY PART IN PREPARATION OF THIS PCM PLAN.

SIGNATURE: *Walter C. Pennington*

DATE: _____
SEAL:

PRINTED NAME: WALTER PENNINGTON, PE
EMAIL ADDRESS: WALT.PENNINGTON@MERRICK.COM

CITY OF COLORADO SPRINGS STATEMENT:
FILED IN ACCORDANCE WITH SECTION 7.7.906 OF THE CODE OF THE CITY OF COLORADO SPRINGS, 2001, AS AMENDED.

FOR CITY ENGINEER _____ DATE _____

CONDITIONS:

CIVIL ENGINEER	LANDSCAPE ARCHITECT	STRUCTURAL ENGINEER	GEOTECHNICAL ENGINEER	SURVEYOR	ENVIRONMENTAL
MERRICK & COMPANY 2480 W. 26TH AVENUE, SUITE B225 DENVER, CO 80211 (303) 964-3333 CONTACT: WALTER PENNINGTON, P.E.	THE ARCHITERRA GROUP 5881 SOUTH DEFRAME ST. LITTLETON, COLORADO 80127 (303) 948-0766 CONTACT: MARK TAYLOR, PLA, ASLA	SM&R STRUCTURAL ENGINEERS INC. 215 S. WADSWORTH BLVD, SUITE 320 LAKEWOOD, CO 80226 (303) 274-8656 CONTACT: DAVID BLANCHETTE, P.E.	VIVID ENGINEERING GROUP INC. 1053 ELKTON DRIVE COLORADO SPRINGS, CO 80907 (719) 896-4356 CONTACT: BRYSEN MUSTAIN	MERRICK & COMPANY 5970 GREENWOOD PLAZA BLVD GREENWOOD VILLAGE, CO 80111 (303) 751-0741 CONTACT: TODD BEERS, P.L.S.	CORVUS ENVIRONMENTAL CONSULTING, LLC. 6429 S. MARION PLACE CENTENNIAL, CO 80121 (303) 250-2118 CONTACT: TIM DEMASTERS



CITY OF COLORADO SPRINGS
30 S. NEVADA AVE., SUITE 401
COLORADO SPRINGS, CO 80903
(719) 385-5980

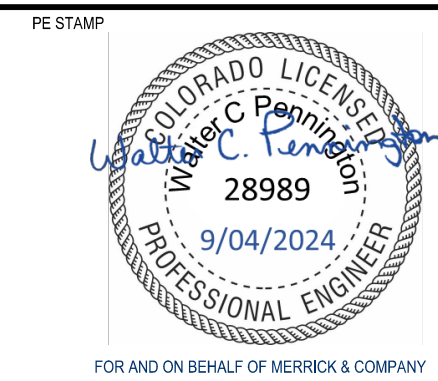

SAND CREEK DETENTION POND NO. 2

COVER SHEET

JOB NUMBER: 65420975
DATE: AUGUST 2024
DWG: ID-101
SHEET 1 of 51

THIS PLAN, SPECIFICATIONS, CONTRACT DOCUMENTS, AND INSTRUMENTS OF SERVICE, PREPARED BY MERRICK & COMPANY, ARE A PART OF THE PROJECT. IT IS NOT INTENDED OR REPRESENTED TO BE SUITABLE FOR REUSE IN WHOLE OR IN PART OR FOR EXTENSION OF THE PROJECT OR ON ANY OTHER PROJECT. REUSE OR MODIFICATION OF ANY INSTRUMENT WITHOUT A WRITTEN INSTRUMENT, WITHOUT THE PROPER EXPRESSION OF THE PROJECT OR ON ANY OTHER PROJECT, SHALL BE AT THE USER'S RISK. THE USER ASSUMES ALL LIABILITY FOR SUCH REUSE OR MODIFICATION.

File Location: Q:\Denver_North\Projects\City of Colorado Springs\Sand Creek Pond No. 2\CAD\CDS\0975 - Cover.dwg Plot Date: 8/26/2024 4:23 PM Last Saved By: TMM, MCMULLEN

GENERAL NOTES

- ALL CONSTRUCTION SHALL BE IN ACCORDANCE WITH THE PROJECT SPECIFICATIONS, THE CITY OF COLORADO SPRINGS STANDARD SPECIFICATIONS, AND CITY OF COLORADO SPRINGS STORMWATER ENTERPRISE DRAINAGE CRITERIA MANUAL AND STORMWATER CONSTRUCTION MANUAL, THE UNLESS OTHERWISE NOTED ON THE DRAWINGS OR IN THE CONTRACT DOCUMENTS.
- DIMENSIONS AND NOTATIONS SUPERSEDE SCALE OF THE DRAWINGS.
- MONUMENTS AND PROJECT SURVEY CONTROL INFORMATION ARE INCLUDED IN THESE DRAWINGS. CONTRACTOR SHALL BE RESPONSIBLE FOR REPLACING OR FIXING ANY MONUMENTS DISTURBED BY THE CONTRACTOR.
- THE CONTRACTOR SHALL BE RESPONSIBLE FOR THE ACCEPTANCE, CONVEYANCE, AND CONTROL OF ALL SURFACE AND SUBSURFACE WATER FLOWS IN AND ENTERING SAND CREEK DRAINAGE FACILITIES AFFECTED BY THIS PROJECT. THE CONTRACTOR SHALL BE RESPONSIBLE FOR OPERATIONS OR ANY OTHER ACCEPTABLE MEANS TO PREVENT POLLUTION OF SAND CREEK IN ACCORDANCE WITH THE COLORADO DEPARTMENT OF PUBLIC HEALTH AND ENVIRONMENT PERMIT REQUIREMENTS. THE CONTRACTOR SHALL SUBMIT A WATER MANAGEMENT PLAN AND CANNOT BEGIN CONSTRUCTION UNTIL THE PLAN IS APPROVED BY THE OWNER. THE CONTRACTOR SHALL BE RESPONSIBLE FOR ALL DAMAGE INCLUDING DAMAGE TO STRUCTURES, LOSS OF TOPSOIL, AND LOSS OF SEED CAUSED BY FLOWS UNTIL THE PROJECT IS ACCEPTED BY THE OWNER. ALL WORK SHALL BE DONE IN A DRY CONDITION.
- UNDERGROUND UTILITIES IN THE AREA OF CONSTRUCTION WERE LOCATED FROM FIELD INVESTIGATION AND THE AVAILABLE UTILITY RECORDS. THE CONTRACTOR SHALL ASSUME FULL RESPONSIBILITY FOR THE LOCATION AND PROTECTION OF ANY UTILITIES AFFECTED BY THE EXECUTION OF THIS CONTRACT. THE CONTRACTOR SHALL BE RESPONSIBLE FOR CONTACTING 811 CENTRAL LOCATES AND AGENCIES AND FOR THE COORDINATION OF ALL WORK IN THE PROXIMITY OF THE UTILITIES.
- THE CONTRACTOR SHALL NOTE ALL UTILITIES MAY NOT APPEAR ON THESE PLANS AND THE POTENTIAL CONFLICT WITH UTILITIES SHALL BE CONSIDERED IN THE PREPARATION OF COST ESTIMATES AND BIDS.
- THE CONTRACTOR SHALL CONTACT ALL UTILITY OWNERS FOR INSPECTION WHEN WORK IS SCHEDULED ADJACENT TO THE UTILITIES. THE CONTRACTOR IS RESPONSIBLE FOR PROTECTING AFFECTED UTILITIES IN ACCORDANCE WITH THE PLANS, SPECIFICATIONS, AND THE REQUIREMENTS OF THE UTILITY OWNER. THE CONTRACTOR SHALL BE RESPONSIBLE FOR ANY DAMAGE AND COSTS ASSOCIATED WITH INTERRUPTED OR LOST SERVICE DUE TO DAMAGE TO THESE FACILITIES AND SHALL HOLD THE OWNER AND THE OWNER'S REPRESENTATIVES HARMLESS FOR DAMAGE ARISING FROM FAILURE TO PROTECT UTILITIES. IT SHALL BE THE RESPONSIBILITY OF THE CONTRACTOR TO SCHEDULE UTILITY ADJUSTMENTS TO ELIMINATE CONFLICT WITH PROGRESS OF WORK.
- ALL MATERIALS AND WORKMANSHIP SHALL BE SUBJECT TO INSPECTION BY THE OWNER. THE OWNER RESERVES THE RIGHT TO ACCEPT OR REJECT ANY SUCH MATERIALS AND WORKMANSHIP THAT DOES NOT CONFORM TO THE STANDARDS AND SPECIFICATIONS SHOWN IN THE CONTRACT DOCUMENTS.
- THE CONTRACTOR SHALL HAVE ONE (1) SIGNED COPY OF THE APPROVED PLANS, ONE (1) COPY OF THE APPROPRIATE STANDARDS AND SPECIFICATIONS, AND A COPY OF ANY PERMITS NEEDED AT THE JOB SITE AT ALL TIMES.
- THE CONTRACTOR IS RESPONSIBLE FOR ANY AND ALL PERMITS, LICENSE FEES, AND BONDS THAT ARE NECESSARY TO COMPLETE THE CONSTRUCTION OF THIS PROJECT. PERMITS REQUIRED FOR THIS PROJECT INCLUDE, BUT ARE NOT LIMITED TO: CITY GRADING, EROSION AND SEDIMENT QUALITY CONTROL PERMIT, STATE OF COLORADO DEPARTMENT OF PUBLIC HEALTH AND ENVIRONMENT STORMWATER MANAGEMENT PERMITS, DEWATERING AND TRAFFIC CONTROL/ACCESS PERMITS, AND EL PASO COUNTY DUST PERMIT.
- THE CONTRACTOR IS REQUIRED TO OBTAIN ALL NECESSARY PERMITS. FOR CITY PERMITS THE CONTRACTOR SHALL USE ACCELA ONLINE PERMIT SYSTEM.
- A PLAN FOR TRAFFIC CONTROL DURING CONSTRUCTION SHALL BE SUBMITTED TO THE CITY FOR APPROVAL WITH THE PERMIT APPLICATION.
- PRIOR TO COMMENCING CONSTRUCTION ACTIVITIES THE CONTRACTOR SHALL MEET WITH THE OWNER'S REPRESENTATIVE AND RECORD EXISTING CONDITIONS OF THE SITE AND ADJACENT PROPERTY.
- THE CONTRACTOR SHALL REFER TO THE CONTRACT SPECIFICATIONS FOR DESCRIPTION OF MATERIALS REFERRED TO BY SIZE, CLASS, TYPE, DESCRIPTION, OR OTHERWISE SPECIFIED ON THE DRAWINGS.
- THE CONTRACTOR IS RESPONSIBLE FOR SAVING AND PROTECTING ALL EXISTING TREES AND VEGETATION WHERE REMOVAL FOR CONSTRUCTION IS NOT MANDATORY, ALL TREES TO BE REMOVED SHALL BE CONFIRMED BY THE OWNER PRIOR TO REMOVAL. TREES APPROVED FOR REMOVAL SHALL BE REMOVED BY A LICENSED ARBORIST AND STUMPS GROUND DOWN BELOW FINISHED GRADE IF ROOTS ARE NOT REMOVED BY EXCAVATION ACTIVITIES.
- EXISTING TREES OR SHRUBS, NOT SHOWN ON THE DRAWINGS, SHALL BE COORDINATED WITH THE CITY FOR PROTECTION OR REMOVAL.
- UNAUTHORIZED CHANGES AND USES: THE ENGINEER WHO PREPARED THESE PLANS WILL NOT

- BE RESPONSIBLE OR LIABLE FOR UNAUTHORIZED CHANGES TO OR USES OF THESE PLANS. ALL CHANGES TO THE PLANS AND SPECIFICATIONS MUST BE IN WRITING AND MUST BE APPROVED BY THE OWNER AND THE PREPARER OF THESE PLANS.
- THE CONTRACTOR SHALL NOTIFY THE OWNERS REPRESENTATIVE IMMEDIATELY OF ANY FIELD CONDITION NOT CONSISTENT WITH THE CONSTRUCTION DOCUMENTS.
- THE CONTRACTOR SHALL PERFORM ALL WORK WITHIN THE WORK LIMITS AS SHOWN ON THE DRAWINGS AND DISCUSSED IN THE CONTRACT DRAWINGS. IF THE CONTRACTOR DAMAGES ANY EXISTING SITE OR PUBLIC AMENITIES (PAVEMENTS, CURBS, CURB AND GUTTER, SOD, TREES, FENCES, UTILITIES, ETC) OUTSIDE OR WITHIN THE EASEMENTS OR CONSTRUCTION LIMITS, THEY SHALL REMOVE AND REPAIR SUCH TO THE SATISFACTION OF THE INDIVIDUAL PROPERTY OWNERS AT THE CONTRACTOR'S EXPENSE.
- ITEMS TO BE REMOVED SHALL BECOME THE PROPERTY OF THE CONTRACTOR, UNLESS NOTED OTHERWISE IN THE PLANS.
- THE CONTRACTOR SHALL BE RESPONSIBLE FOR PROVIDING THE TEMPORARY EROSION CONTROL MEASURES (WIND AND WATER) DURING THE FULL TERM OF CONSTRUCTION IN ACCORDANCE WITH THESE PLANS AND SPECIFICATIONS.
- ALL DISTURBED AREAS SHALL BE SEEDED IN ACCORDANCE WITH THE PROJECT SPECIFICATIONS. EROSION CONTROL BLANKET SHALL BE INSTALLED ON ALL AREAS WITH SLOPES 3H TO 1V OR STEEPER.
- THE EXACT LIMITS OF THE CONTRACTOR'S PARKING AND STAGING AREA FOR MATERIAL STOCKPILING, AND OFFICE TRAILERS, IF DIFFERENT THAN SHOWN ON THE PLANS, SHALL BE SUBMITTED BY THE CONTRACTOR FOR THE REVIEW AND THE APPROVAL OF THE OWNER'S REPRESENTATIVE.
- ALL REQUIRED UTILITIES FOR THE CONTRACTOR'S STAGING AREA SHALL BE ARRANGED BY THE CONTRACTOR DIRECTLY WITH THE APPROPRIATE UTILITY AGENCY. UTILITY ARRANGEMENTS SHALL BE SUBJECT TO THE APPROVAL OF THE CONTRACTOR TO ENCLOSE AND SET UP HIS OPERATIONAL AREA. ADDITIONALLY, THE CONTRACTOR SHALL RESTORE THE SITE TO ITS ORIGINAL CONDITION TO THE SATISFACTION OF THE OWNER'S REPRESENTATIVE UPON COMPLETION OF THE CONTRACT WORK.
- WASTE MATERIAL PRODUCED AS A RESULT OF THE CONTRACTOR'S OPERATIONS SHALL BE LEGALLY DISPOSED OF OFF THE PROJECT SITE OR AS DIRECTED BY THE OWNER'S REPRESENTATIVE AT THE CONTRACTOR'S EXPENSE.
- THE CONTRACTOR SHALL COMPLY WITH ALL LOCAL, STATE, AND FEDERAL LAWS AND REGULATIONS THAT ARE PERTINENT TO THIS WORK.
- THE CONTRACTOR SHALL BE RESPONSIBLE FOR CONTINUOUS CLEANUP OF ANY TRASH ON THE SITE OR ADJACENT PROPERTIES AND STREETS AS A RESULT OF CONSTRUCTION ACTIVITIES.
- ANY CONSTRUCTION DEBRIS OR MUD TRACKING ONTO THE PUBLIC RIGHT-OF-WAY, RESULTING FROM THE PROJECT, SHALL BE IMMEDIATELY REMOVED BY THE CONTRACTOR. THE CONTRACTOR SHALL IMMEDIATELY FIX ANY EXCAVATION, OR PAVEMENT FAILURE CAUSED BY THE PROJECT, AND SHALL PROPERLY BARRICADE THE SITE UNTIL CONSTRUCTION IS COMPLETE.
- THE CONTRACTOR SHALL BE SOLELY AND COMPLETELY RESPONSIBLE FOR THE CONDITIONS AT, AND ADJACENT TO THE JOB SITE, INCLUDING BUT NOT LIMITED TO TRENCH EXCAVATIONS AND SHORING, TRAFFIC CONTROL, SECURITY, AND SAFETY OF ALL PERSONS AND PROPERTY, DURING THE PERFORMANCE OF THE WORK. THIS REQUIREMENT SHALL APPLY CONTINUOUSLY, AND SHALL NOT BE LIMITED TO NORMAL WORKING HOURS. THE DUTY OF THE OWNER TO CONDUCT CONSTRUCTION REVIEW OF THE CONTRACTOR'S PERFORMANCE IS NOT INTENDED TO INCLUDE REVIEW OF THE ADEQUACY OF THE CONTRACTOR'S SAFETY MEASURES IN OR NEAR THE CONSTRUCTION SITE.
- THE CONTRACTOR SHALL BE RESPONSIBLE FOR ANY NEEDED DEWATERING OPERATIONS INCLUDING ANY REQUIRED PERMITS FOR DEWATERING OPERATIONS.
- ALL GRADES SHOWN ARE FINISHED GRADES, UNLESS OTHERWISE NOTED ON THE DRAWINGS.
- ALL SLOPES SHOWN ARE DIAGRAMMATIC AND SHALL BE ROUNDED AT TOP AND BOTTOM.
- THE CONTRACTOR SHALL BE RESPONSIBLE FOR PROVIDING THE CITY WITH A MARKED SET OF (REDLINES) CONSTRUCTION DRAWINGS SHOWING ALL CHANGES MADE DURING CONSTRUCTION.

SURVEY NOTES:
 SURVEY COMPLETED BY MERRICK & COMPANY IN FALL 2021 AND SUMMER 2022.
 VERTICAL DATUM: NAVD88
 HORIZONTAL DATUM: NAD83 STATE PLANE COLORADO CENTRAL ZONE,
 MODIFIED GROUND (COMBINED SCALE FACTOR = 0.99963449)

LEGEND

---	6515	---	EXISTING CONTOUR MAJOR
---	6501	---	EXISTING CONTOUR MINOR
---	6515	---	PROPOSED CONTOUR MAJOR
---	6501	---	PROPOSED CONTOUR MINOR
---	E	---	EXISTING ELECTRICAL
---	SS	---	EXISTING SANITARY SEWER
---	SS	---	ABANDONED SANITARY SEWER
---	ST	---	EXISTING STORM SEWER
---	WL	---	EXISTING WATER
---	G	---	EXISTING GAS
---	---	---	ALIGNMENT CENTERLINE
---	---	---	PROPOSED STORM SEWER
---	---	---	PROPERTY LINE
---	---	---	EASEMENT
---	---	---	PROJECT BOUNDARY
---	---	---	REGULATORY 100-YEAR FLOODPLAIN
---	---	---	PROPOSED 100-YEAR WSE
---	---	---	PROPOSED 2-YEAR WSE
---	---	---	PROPOSED WETLAND SWALE
---	---	---	PROPOSED SOIL RIPRAP (PLAN)
---	---	---	PROPOSED SOIL RIPRAP (SECTION)
---	---	---	PROPOSED VOID-PERMEATED RIPRAP (PLAN)
---	---	---	PROPOSED VOID-PERMEATED RIPRAP (SECTION)
---	---	---	PROPOSED GROUTED BOULDER (PLAN)
---	---	---	PROPOSED AGGREGATE ACCESS ROAD
---	---	---	TRUEGRID PAVERS
---	---	---	PROPOSED ARTICULATED CONCRETE MAT
---	---	---	PROPOSED CONCRETE
---	---	---	EXISTING SOIL CEMENT (PLAN)
---	---	---	EXISTING SOIL CEMENT (SECTION)
---	---	---	EXISTING CONCRETE
---	---	---	EXISTING CONCRETE RUBBLE/ EXISTING RIPRAP
---	---	---	EXISTING WETLANDS
---	---	---	EXISTING ASPHALT
---	---	---	EXISTING TREE
---	---	---	FLOW DIRECTION

ABBREVIATIONS

AVG	AVERAGE
BW	BOTTOM OF WALL (ELEV)
CBC	CONCRETE BOX CULVERT
CDPHE	COLORADO DEPARTMENT OF PUBLIC HEALTH AND ENVIRONMENT
CFS	CUBIC FEET PER SECOND
CL	CENTERLINE
CLR	CLEAR
CMP	CORRUGATED METAL PIPE
CONC	CONCRETE
CP	CONTROL POINT
D	DEPTH
D/S	DOWNSTREAM
DBPS	DRAINAGE BASIN PLANNING STUDY
DEMO	DEMOLISH
DET	DETAIL
DIA	DIAMETER
DWG	DRAWING
E	EACH
EA	EASTING
EG	EXISTING GROUND
ELE/ELEV	ELEVATION
EOR	EDGE OF ROAD
EX/EXIST	EXISTING
FES	FLARED END SECTION
FG	FINISHED GRADE
FO	FIBER OPTIC
FT	FEET
H	HEIGHT
HDPE	HIGH DENSITY POLYETHYLENE PIPE
HOR	HORIZONTAL
HP	HIGH POINT
IN	INCH
INV	INVERT
LF	LINEAL FEET
MAX	MAXIMUM
MAINT	MAINTENANCE
MH	MANHOLE
MIN	MINIMUM
N	NORTHING
NO.	NUMBER
NTS	NOT TO SCALE
P&P	PLAN AND PROFILE
PR 100-YR	PROPOSED 100-YEAR FLOODPLAIN
PVC	POLYVINYL CHLORIDE PIPE
QL	UTILITY QUALITY LEVEL
RCP	REINFORCED CONCRETE PIPE
RD	ROAD
REG 100-YR	REGULATORY 100-YEAR FLOODPLAIN
ROW	RIGHT-OF-WAY
SAN	SANITARY [SEWER]
SHT	SHEET
SS	SANITARY SEWER
STA	STATION
STR	STRUCTURE
STRM	STORM SEWER
SWMP	STORM WATER MANAGEMENT PLAN
TOB	TOP OF BOULDER
TOG	TOP OF GROUT
TOS	TOP OF SLAB
TW	TOP OF WALL (ELEV)
TYP	TYPICAL
U/S	UPSTREAM
USBR	UNITED STATES BUREAU OF RECLAMATION
VERT	VERTICAL
W	WIDTH/WITH
WSEL/WSE	WATER SURFACE ELEVATION
WTR	WATER LINE
YR	YEAR

DETAIL

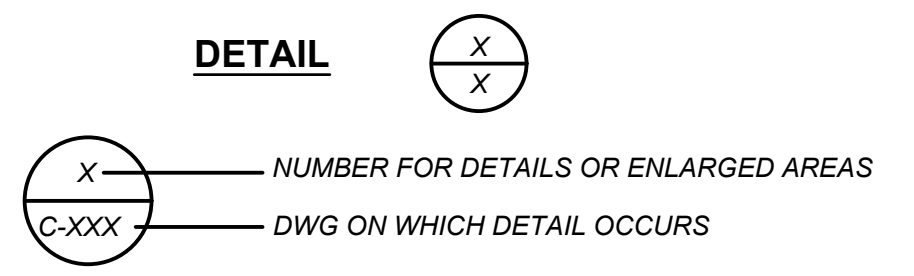

SECTION

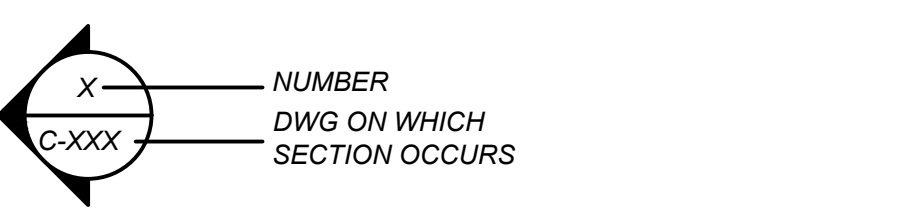

REV	REVISION DESCRIPTION	DATE	CHND	CHKD	APPR

CALL BEFORE YOU DIG

Know what's below.
Call before you dig.

CITY OF COLORADO SPRINGS
 30 S. NEVADA AVE., SUITE 401
 COLORADO SPRINGS, CO 80903
 (719) 385-5980

Engineering | Architecture | Design-Build | Surveying | Planning | Geospatial Solutions
 2480 W. 26TH AVE., UNIT B225 - DENVER COLORADO 80211
 TEL. 303-751-0741, FAX 303-751-2581
 www.merrick.com

PE STAMP

FOR AND ON BEHALF OF MERRICK & COMPANY

TITLE

SAND CREEK DETENTION POND NO. 2

GENERAL NOTES AND LEGEND

JOB NUMBER: 65420975
 DATE: AUGUST 2024
 DWG: ID-102
 SHEET 2 of 51

THE USER SHALL BE RESPONSIBLE FOR OBTAINING ALL NECESSARY PERMITS AND APPROVALS FROM ALL APPLICABLE AGENCIES AND AUTHORITIES. THE USER SHALL BE RESPONSIBLE FOR OBTAINING ALL NECESSARY PERMITS AND APPROVALS FROM ALL APPLICABLE AGENCIES AND AUTHORITIES. THE USER SHALL BE RESPONSIBLE FOR OBTAINING ALL NECESSARY PERMITS AND APPROVALS FROM ALL APPLICABLE AGENCIES AND AUTHORITIES.

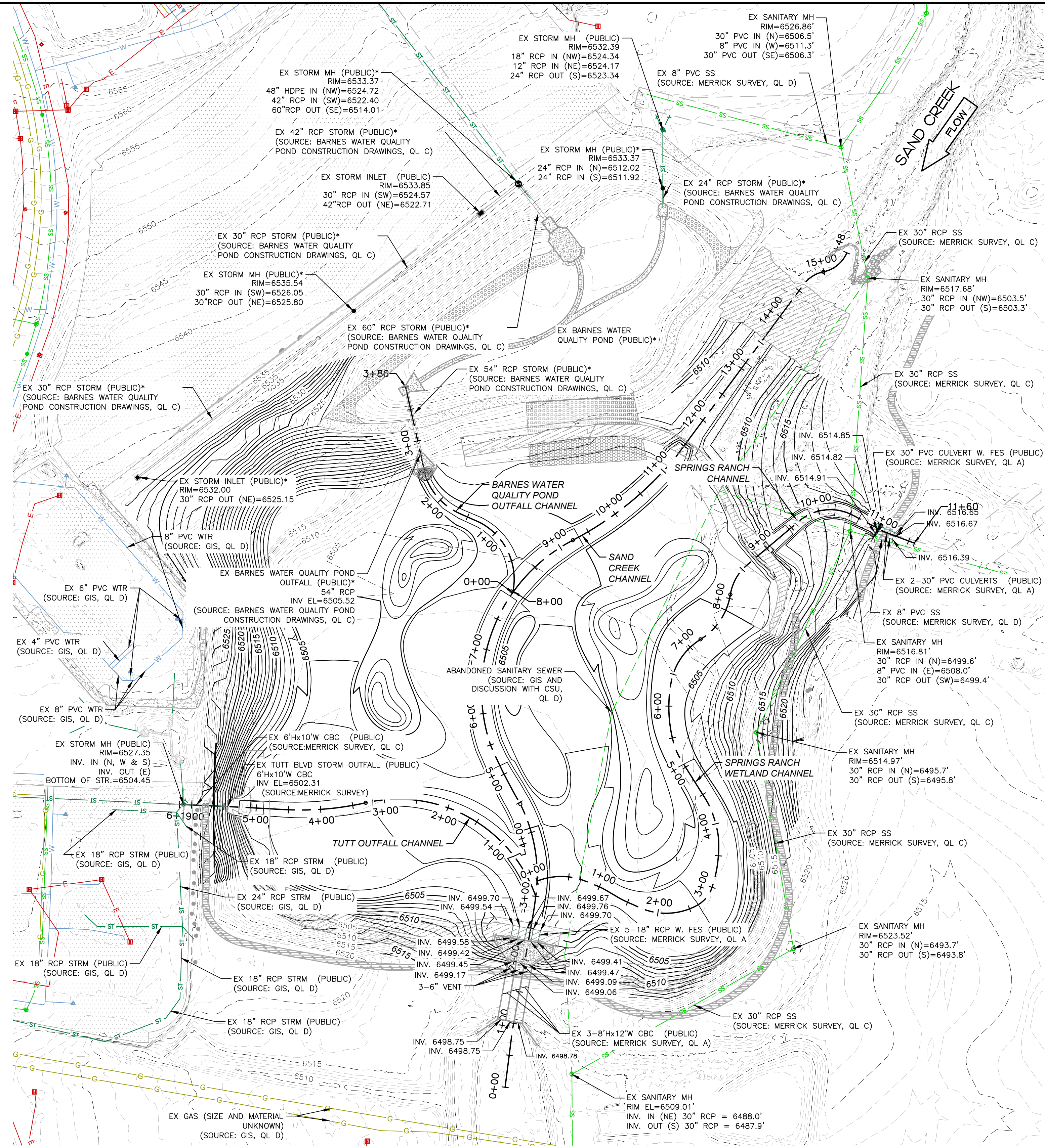

PLAN
SCALE: 1" = 100'

UTILITY NOTES:

- UTILITY LINES AS SHOWN ON THE PLANS ARE PLOTTED FROM THE BEST AVAILABLE INFORMATION. SUBSECTION 105.10 OF THE COT STANDARD SPECIFICATIONS FOR ROAD AND BRIDGE CONSTRUCTION, 2017 (AS REVISED) SHALL APPLY FOR THIS CONTRACT.
- THE INFORMATION SHOWN ON THESE PLANS CONCERNING TYPE AND LOCATION OF UTILITIES IS NOT GUARANTEED TO BE ACCURATE OR ALL INCLUSIVE. SERVICES TO INDIVIDUAL RESIDENCES, PLACES OF BUSINESS, AND OTHER PRIVATELY-OWNED UTILITIES ARE NORMALLY NOT SHOWN ON THE DRAWINGS. IT SHALL BE THE CONTRACTOR'S RESPONSIBILITY TO VERIFY ALL LOCATIONS OF EXISTING STRUCTURES AND UTILITIES SHOWN ON THE DRAWINGS AND TO ASCERTAIN WHETHER ANY OTHER STRUCTURES AND UTILITIES MAY EXIST. EVERY REASONABLE MEANS SHALL BE USED, INCLUDING FIELD LOCATION OF THE UTILITY. THE CONTRACTOR ASSUMES RESPONSIBILITY FOR THE PROTECTION OF ALL UTILITIES DURING THE WORK. REPAIR OF DAMAGE TO EXISTING UTILITIES DURING CONSTRUCTION SHALL BE THE RESPONSIBILITY OF THE CONTRACTOR. PRIOR TO ANY EXCAVATION, CONTACT THE UTILITY NOTIFICATION CENTER OF COLORADO (UNCC) AT: 1 (800) 922-1987 AT LEAST TWO WORKING DAYS PRIOR TO DIGGING.
- THE CONTRACTOR SHALL VERIFY AND DOCUMENT THE CONDITION OF EXISTING UTILITIES (VISIBLE FACILITIES) WITH THE ENGINEER AND REPRESENTATIVES FROM THE UTILITY COMPANIES PRIOR TO COMMENCEMENT OF CONSTRUCTION.
- IT IS SUGGESTED THAT THE CONTRACTOR INITIATE A REQUEST TO XCEL ENERGY FOR ANY CONSTRUCTION-RELATED TEMPORARY ELECTRICAL POWER SOURCES AS SOON AS POSSIBLE. IN SOME INSTANCES UP TO 30 DAYS MAY BE REQUIRED TO PROVIDE THE SOURCES.

DISCLAIMER REGARDING UNDERGROUND UTILITIES:

EXISTING UTILITIES ARE DEPICTED ON THESE DRAWINGS AND IN ACCORDANCE WITH THE ACHIEVED "QUALITY LEVELS" FOR EACH UTILITY AS DEFINED IN THE AMERICAN SOCIETY OF CIVIL ENGINEERS' DOCUMENT ASCE 38" STANDARD GUIDELINE FOR THE COLLECTION AND DEPICTION OF EXISTING SUBSURFACE UTILITY DATA" AND AS REQUIRED BY C.R.S. 9-1.5-101 ET. SEQ.

AS IT APPLIES TO THE DEPICTION OF EXISTING UNDERGROUND UTILITY INFORMATION, THE STAMP AND SEAL ON THIS UTILITY PLAN REFLECT ONLY THAT DEPICTION OF THE EXISTING UNDERGROUND UTILITY MEETS THE NOTED ASCE 38 QUALITY LEVEL, AND DOES NOT SERVE AS A GUARANTEE, REPRESENTATION, OR WARRANTY THAT THE DEPICTED UTILITIES EXIST IN THE NOTED LOCATIONS.

RELIANCE UPON THIS DATA FOR RISK MANAGEMENT PURPOSES DURING BIDDING DOES NOT RELIEVE THE EXCAVATOR OR UTILITY OWNER FROM FOLLOWING ALL APPLICABLE UTILITY DAMAGE PREVENTION STATUTES, POLICIES, AND/OR PROCEDURES DURING EXCAVATION. IT IS IMPORTANT THAT THE CONTRACTOR INVESTIGATES AND UNDERSTAND THE SCOPE OF WORK AND CONSULTS WITH THAT PROJECT OWNER AND THE ENGINEER REGARDING THE SCOPE AND LIMITS OF THE INVESTIGATIONS LEADING TO THESE UTILITY DEPICTIONS.

UTILITY QUALITY LEVEL DESCRIPTIONS:

- QUALITY LEVEL A:** PRECISE HORIZONTAL AND VERTICAL LOCATION OF UTILITIES OBTAINED BY THE ACTUAL EXPOSURE (OR VERIFICATION OF PREVIOUSLY EXPOSED AND SURVEYED UTILITIES) AND SUBSEQUENT MEASUREMENT OF SUBSURFACE UTILITIES, USUALLY AT A SPECIFIC POINT. MINIMALLY INTRUSIVE EXCAVATION EQUIPMENT IS TYPICALLY USED TO MINIMIZE THE POTENTIAL FOR UTILITY DAMAGE. A PRECISE HORIZONTAL AND VERTICAL LOCATION, AS WELL AS OTHER UTILITY ATTRIBUTES, IS SHOWN IN PLAN DOCUMENTS. ACCURACY IS USUALLY SET TO 15-MM VERTICAL AND TO APPLICABLE HORIZONTAL SURVEY AND MAPPING ACCURACY AS DEFINED OR EXPECTED BY THE PROJECT OWNER.
- QUALITY LEVEL B:** INFORMATION OBTAINED THROUGH THE APPLICATION OF APPROPRIATE SURFACE GEOPHYSICAL METHODS TO DETERMINE THE EXISTENCE AND APPROXIMATE HORIZONTAL POSITION OF SUBSURFACE UTILITIES. QUALITY LEVEL B DATA SHOULD BE REPRODUCIBLE BY SURFACE GEOPHYSICS AT ANY POINT OF THEIR DEPICTION. THIS INFORMATION IS SURVEYED TO APPLICABLE TOLERANCES DEFINED BY THE PROJECT AND REDUCED ONTO PLAN DOCUMENTS.
- QUALITY LEVEL C:** INFORMATION OBTAINED BY SURVEYING AND PLOTTING VISIBLE ABOVE-GROUND UTILITY FEATURES AND BY USING PROFESSIONAL JUDGMENT IN CORRELATING THIS INFORMATION TO QUALITY LEVEL D INFORMATION.
- QUALITY LEVEL D:** INFORMATION DERIVED FROM EXISTING RECORDS OR ORAL RECOLLECTIONS.

*THIS INFRASTRUCTURE ELEMENT IS PROPOSED AS PART OF THE BARNES WATER QUALITY POND PROJECT, WHICH IS TO BE COMPLETED BEFORE CONSTRUCTION OF SAND CREEK POND NO. 2 RESTORATION BEGINS.

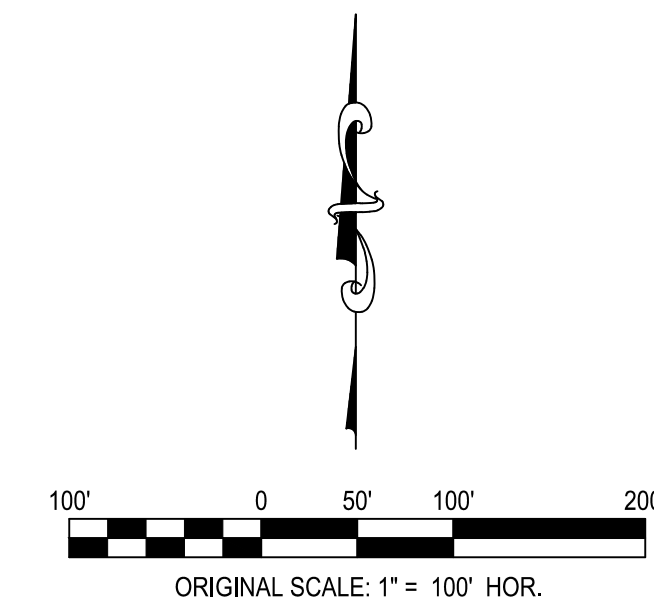

File Location: D:\Denver_North\Projects\City of Colorado Springs\Sand Creek Pond No. 2\CAD\CDS\0975-SUE.dwg Plot Date: 8/26/2024 4:24 PM Last Saved By: TIM.MCWULLEN

REV	REVISION DESCRIPTION	DATE	CHND	CHKD	APPR

CALL BEFORE YOU DIG

Know what's below.
Call before you dig.

CITY OF COLORADO SPRINGS
30 S. NEVADA AVE., SUITE 401
COLORADO SPRINGS, CO 80903
(719) 385-5980

MERRICK
Engineering | Architecture | Design-Build | Surveying | Planning | Geospatial Solutions
2480 W. 26TH AVE., UNIT B225 - DENVER COLORADO 80211
TEL. 303-751-0741, FAX 303-751-2581
www.merrick.com

PE STAMP

FOR AND ON BEHALF OF MERRICK & COMPANY

TITLE

SAND CREEK DETENTION POND NO. 2

SUBSURFACE UTILITY ENGINEERING PLAN

JOB NUMBER	65420975
DATE	AUGUST 2024
DWG	C-101
SHEET	3 of 51

THE CITY OF COLORADO SPRINGS IS PROVIDING THIS INFORMATION AS A SERVICE TO THE PUBLIC. IT IS NOT INTENDED TO BE USED FOR ANY OTHER PURPOSE. THE CITY OF COLORADO SPRINGS DOES NOT WARRANT THE ACCURACY OF THE INFORMATION PROVIDED. THE CITY OF COLORADO SPRINGS DOES NOT ASSUME ANY LIABILITY FOR ANY DAMAGE TO PERSONS OR PROPERTY THAT MAY OCCUR AS A RESULT OF THE USE OF THIS INFORMATION.

File Location: D:\Denver_North\Projects\City of Colorado Springs\Sand Creek Pond No. 2\CAD\03\0975-PROJECT_CONTROL.SDWG Plot Date: 8/26/2024 4:27 PM Last Saved By: TIM.MCMULLEN

MATCHLINE SEE DWG C-103

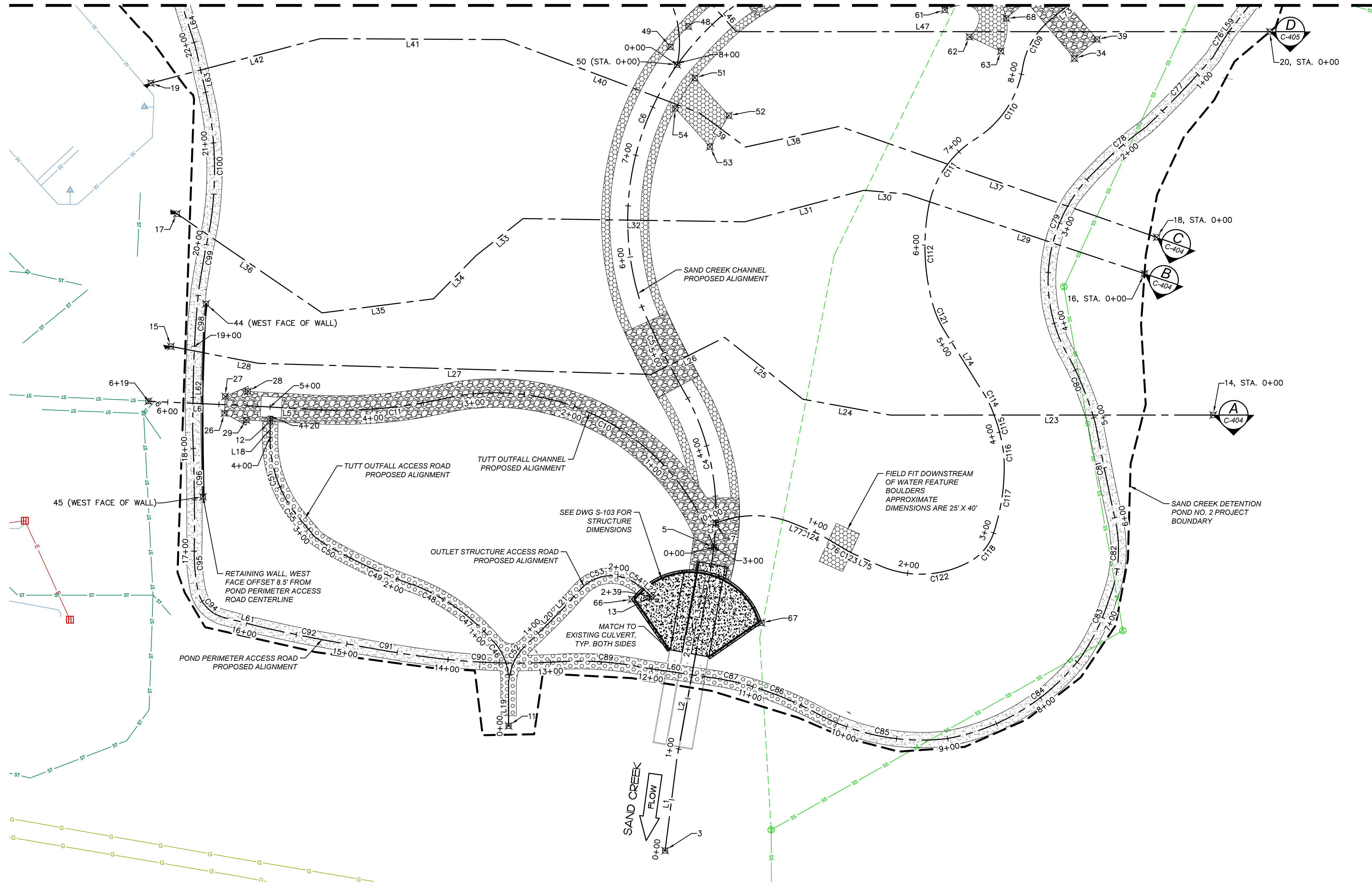

- NOTES:**
- SEE LINE, CURVE, AND POINT TABLES ON THE NEXT DRAWING, DWG C-103.
 - POINTS 66 AND 67 ARE APPROXIMATE LOCATIONS. FOLLOW DIMENSIONS ON DWG S-103, USING THE CORNERS OF THE EXISTING CONCRETE BOX CULVERT AS REFERENCE LOCATIONS.

PLAN
SCALE: 1" = 50'

REV	REVISION DESCRIPTION	DATE	CHND	CHKD	APPR

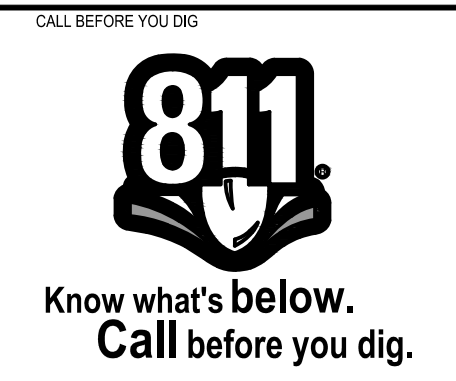

CITY OF COLORADO SPRINGS
 30 S. NEVADA AVE., SUITE 401
 COLORADO SPRINGS, CO 80903
 (719) 385-5980

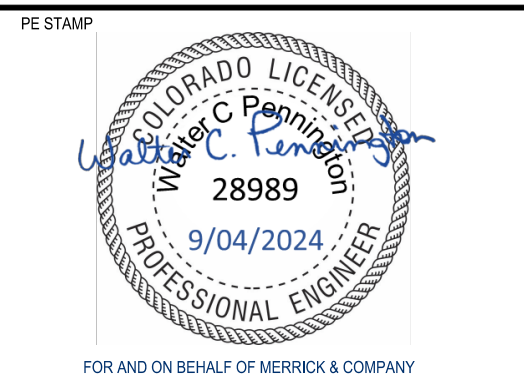

TITLE: SAND CREEK DETENTION POND NO. 2
 PROJECT CONTROLS (SOUTH)

JOB NUMBER	65420975
DATE	AUGUST 2024
DWG	C-102
SHEET	4 of 51

THE CITY OF COLORADO SPRINGS IS PROVIDING THIS INFORMATION AS AN INSTRUMENT OF SERVICE. SERVICES BY MERRICK AND COMPANY, INC. ARE THE PROPERTY OF MERRICK AND COMPANY, INC. AND ARE NOT TO BE REPRODUCED OR TRANSMITTED IN ANY FORM OR BY ANY MEANS, ELECTRONIC OR MECHANICAL, INCLUDING PHOTOCOPYING, RECORDING, OR BY ANY INFORMATION STORAGE AND RETRIEVAL SYSTEM, WITHOUT THE PRIOR WRITTEN CONSENT OF MERRICK AND COMPANY, INC. THIS INFORMATION IS PROVIDED AS IS AND WITHOUT WARRANTY OF ANY KIND, EXPRESS OR IMPLIED, INCLUDING BUT NOT LIMITED TO THE WARRANTIES OF MERCHANTABILITY, FITNESS FOR A PARTICULAR PURPOSE, AND NONINFRINGEMENT OF THIRD PARTY RIGHTS. ALL RIGHTS RESERVED.

File Location: D:\Denver_North\Projects\City of Colorado Springs\Sand Creek Pond No. 2\CAD\CDS\0975- EXISTING CONDITIONS.dwg Plot Date: 9/26/2024 4:27 PM Last Saved By: TIMMCMULLEN

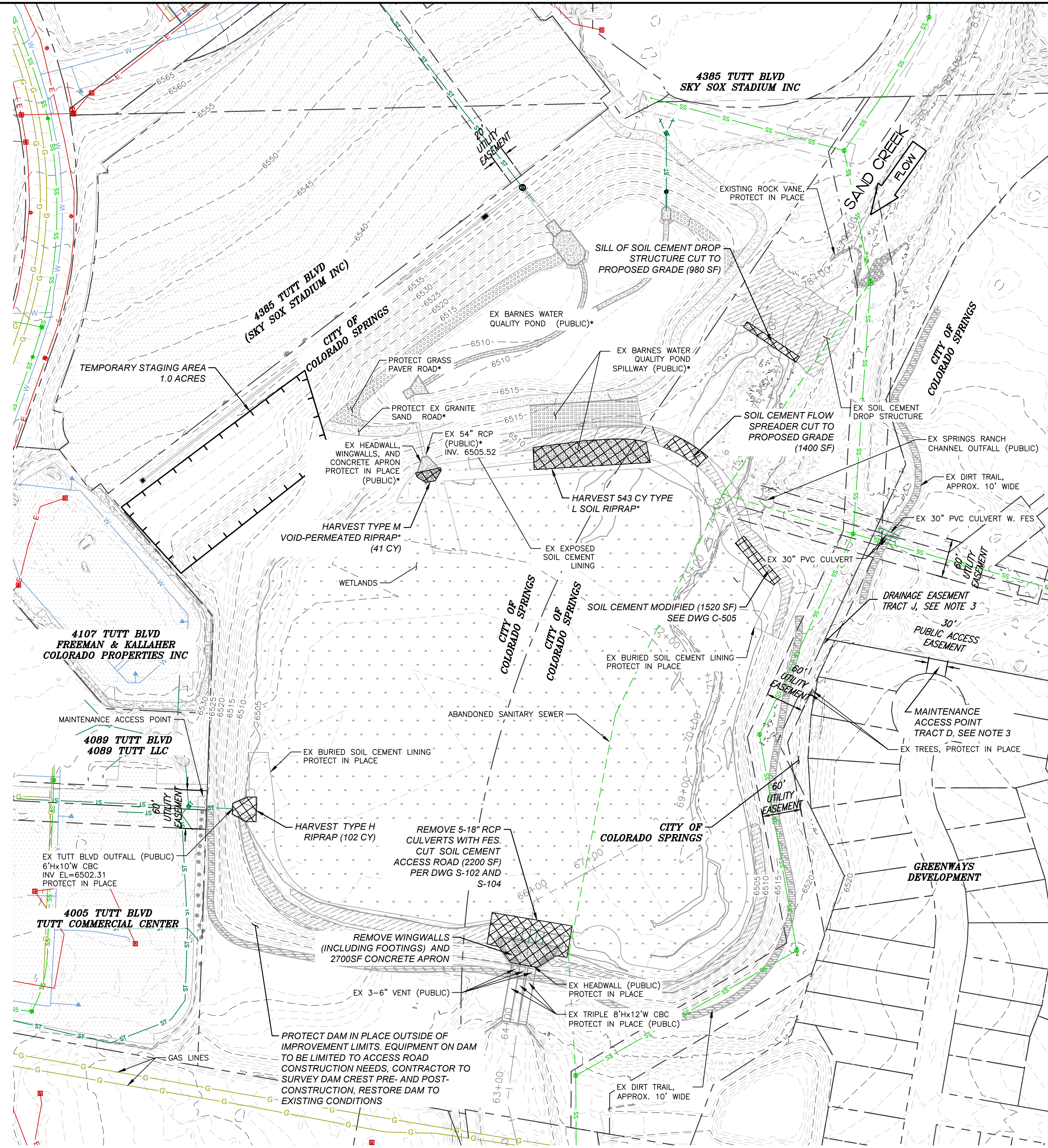

- NOTES:**
- PROPERTY OWNERSHIP INFORMATION RETRIEVED FROM CITY OF COLORADO SPRINGS SPRINGVIEW WEBSITE
 - EASEMENT INFORMATION PROVIDED BY GREENWAYS DEVELOPMENT AND DRAINAGE REPORTS
 - TRACT D FROM THE GREENWAYS DEVELOPMENT IS USED FOR PUBLIC ACCESS, OPEN SPACE, LANDSCAPING, PUBLIC UTILITIES, PUBLIC IMPROVEMENTS, TRAILS, FENCES AND SIGNAGE. TRACT J IS USED FOR PUBLIC DRAINAGE, PUBLIC UTILITIES, AND TRAILS/OPEN SPACE.

THIS INFRASTRUCTURE ELEMENT IS PROPOSED AS PART OF THE BARNES WATER QUALITY POND PROJECT, WHICH IS TO BE COMPLETED BEFORE CONSTRUCTION OF SAND CREEK POND NO. 2 RESTORATION BEGINS.

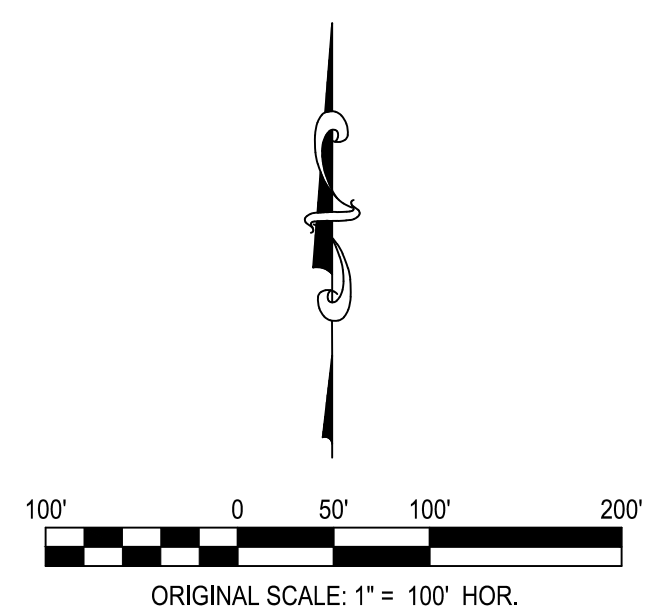

PLAN
SCALE: 1" = 100'

REV	REVISION DESCRIPTION	DATE	CHND	CHKD	APPR

CALL BEFORE YOU DIG

Know what's below.
Call before you dig.

CITY OF COLORADO SPRINGS
 30 S. NEVADA AVE., SUITE 401
 COLORADO SPRINGS, CO 80903
 (719) 385-5980

MERRICK
 Engineering | Architecture | Design-Build | Surveying | Planning | Geospatial Solutions
 2480 W. 26TH AVE., UNIT B225 - DENVER COLORADO 80211
 TEL. 303-751-0741, FAX 303-751-2581
 www.merrick.com

PE STAMP

FOR AND ON BEHALF OF MERRICK & COMPANY

TITLE

SAND CREEK DETENTION POND NO. 2

EXISTING CONDITIONS, PROPERTY OWNERSHIP,
AND DEMOLITION PLAN

JOB NUMBER: 65420975
 DATE: AUGUST 2024
 DWG: C-201
 SHEET: 6 of 51

THE NEW ORANGE ENGINEERING DESIGN CENTER IS AN INSTRUMENT OF SERVICE PROVIDED BY MERRICK AND COMPANY, INC. A SERVICE CENTER OF MERRICK AND COMPANY, INC. ALL INFORMATION IS FOR INFORMATION ONLY AND DOES NOT CONSTITUTE A CONTRACT. THE PROJECT, REUSE OR MODIFICATION OF ANY INFORMATION NOT A FINISHED INSTRUMENT WITHOUT THE PRIOR EXPRESS WRITTEN CONSENT OF MERRICK AND COMPANY SHALL BE AT THE USER'S RISK FOR THE USER'S USE WITHOUT LIABILITY TO MERRICK AND COMPANY.

File Location: D:\Denver_North\Projects\City of Colorado Springs\Sand Creek Pond No. 2\CAD\03\0975-CONSTRUCTION-ACCESS.dwg Plot Date: 8/26/2024 4:28 PM Last Saved By: TIM MCWULLEN

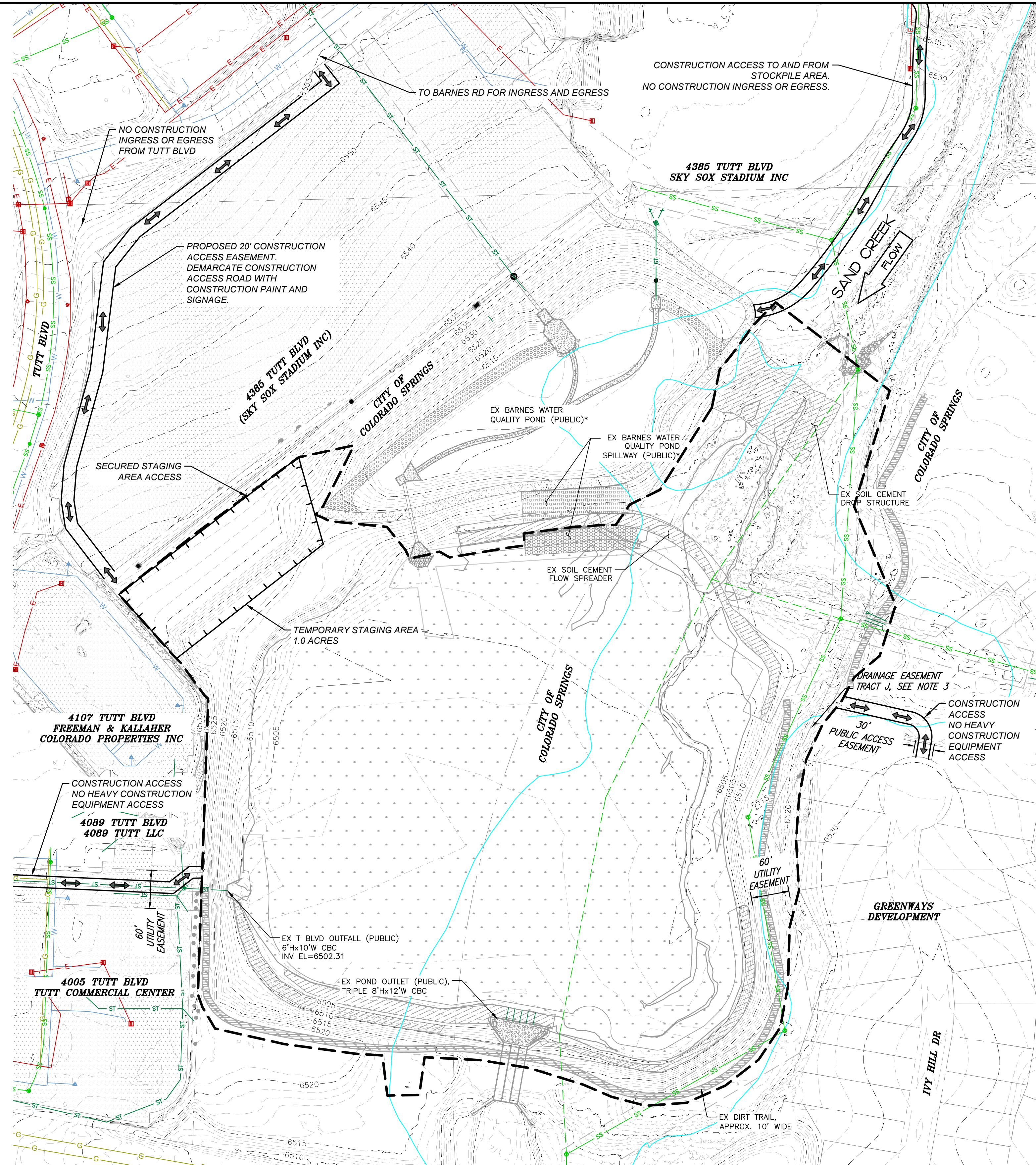

- NOTES:
1. PROPERTY OWNERSHIP INFORMATION RETRIEVED FROM CITY OF COLORADO SPRINGS SPRINGSVIEW WEBSITE
 2. EASEMENT INFORMATION PROVIDED BY GREENWAYS DEVELOPMENT AND DRAINAGE REPORTS
 3. TRACT D FROM THE GREENWAYS DEVELOPMENT IS USED FOR PUBLIC ACCESS, OPEN SPACE, LANDSCAPING, PUBLIC UTILITIES, PUBLIC IMPROVEMENTS, TRAILS, FENCES AND SIGNAGE. TRACT J IS USED FOR PUBLIC DRAINAGE, PUBLIC UTILITIES, AND TRAILS/OPEN SPACE.

*THIS INFRASTRUCTURE ELEMENT IS PROPOSED AS PART OF THE BARNES WATER QUALITY POND PROJECT, WHICH IS TO BE COMPLETED BEFORE CONSTRUCTION OF SAND CREEK POND NO. 2 RESTORATION BEGINS.

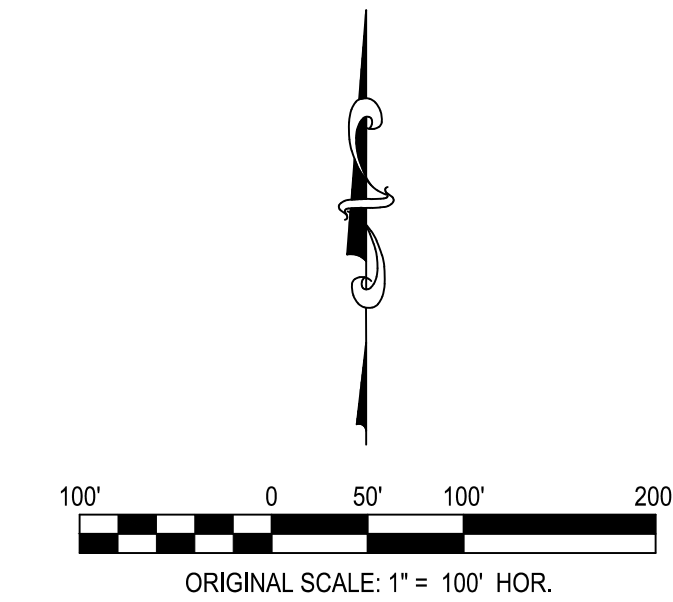

PLAN
SCALE: 1" = 100'

REV	REVISION DESCRIPTION	DATE	CHND	CHKD	APPR

CALL BEFORE YOU DIG

Know what's below.
Call before you dig.

CITY OF COLORADO SPRINGS
30 S. NEVADA AVE., SUITE 401
COLORADO SPRINGS, CO 80903
(719) 385-5980

Engineering | Architecture | Design-Build | Surveying | Planning | Geospatial Solutions
2480 W. 26TH AVE., UNIT B225 - DENVER COLORADO 80211
TEL. 303-751-0741, FAX 303-751-2581
www.merrick.com

PE STAMP

FOR AND ON BEHALF OF MERRICK & COMPANY

TITLE

SAND CREEK DETENTION POND NO. 2

CONSTRUCTION ACCESS, STAGING, AND GENERAL TRAFFIC CONTROL

JOB NUMBER 65420975

DATE AUGUST 2024

DWG C-301

SHEET 7 of 51

THE CITY OF COLORADO SPRINGS, COLORADO, HAS REVIEWED THIS PLAN AND FOUND IT TO BE IN ACCORDANCE WITH THE CITY ENGINEERING DEPARTMENT'S STANDARDS AND SPECIFICATIONS FOR THE DESIGN OF POND RESTORATION PROJECTS. IT IS NOT INTENDED OR REPRESENTED TO BE SUITABLE FOR REUSE IN WHOLE OR IN PART FOR ANY OTHER PROJECT WITHOUT THE WRITTEN CONSENT OF THE PROJECTOR OR ANOTHER ENGINEER. THE CITY OF COLORADO SPRINGS, COLORADO, DOES NOT WARRANT THE ACCURACY OF THE INFORMATION PROVIDED HEREON. THE USER SHALL BE RESPONSIBLE FOR OBTAINING ALL NECESSARY PERMITS AND APPROVALS FROM THE APPROPRIATE AGENCIES.

File Location: D:\Denver_North\Projects\City of Colorado Springs\Sand Creek Pond No. 2\CAD\CDS\0875-SITE_PLAN\KEY.dwg Plot Date: 8/26/2024 5:22 PM Last Saved By: TIM.MCMULLEN

NOTE: HARVEST AND STOCKPILE 1-FOOT DEPTH OF TOPSOIL FROM THE POND BOTTOM. THIS STOCKPILE IS REFERRED TO AS TOPSOIL STOCKPILE #1. THE POND BOTTOM IS APPROXIMATELY DEFINED AS THE AREA SHOWN AS WETLANDS ON DWG. C-201. HARVEST AND STOCKPILE AN ADDITIONAL 6-INCH DEPTH OF TOPSOIL FROM THE POND BOTTOM. THIS STOCKPILE IS REFERRED TO AS TOPSOIL STOCKPILE #2. DO NOT MIX TOPSOIL STOCKPILE #1 AND TOPSOIL STOCKPILE #2. PLACE TOPSOIL FROM TOPSOIL STOCKPILE #1 AS THE TOP 6-INCHES OF FINISHED GRADE ON ALL AREAS WITH UPLAND SEED SHOWN ON DWG. L-100. HAUL ALL REMAINING TOPSOIL FROM TOPSOIL STOCKPILE #1 TO THE OFFSITE STOCKPILE LOCATION. DO NOT MIX WITH OTHER OFFSITE STOCKPILES. PLACE TOPSOIL FROM TOPSOIL STOCKPILE #2 AS THE TOP 6-INCHES OF FINISHED GRADE ON ALL AREAS WITH WETLAND/RIPARIAN SEED OR WETLAND PLUGS SHOWN ON DWG. L-100. HAUL ALL REMAINING TOPSOIL FROM TOPSOIL STOCKPILE #2 TO THE OFFSITE STOCKPILE LOCATION. DO NOT MIX WITH OTHER OFFSITE STOCKPILES.

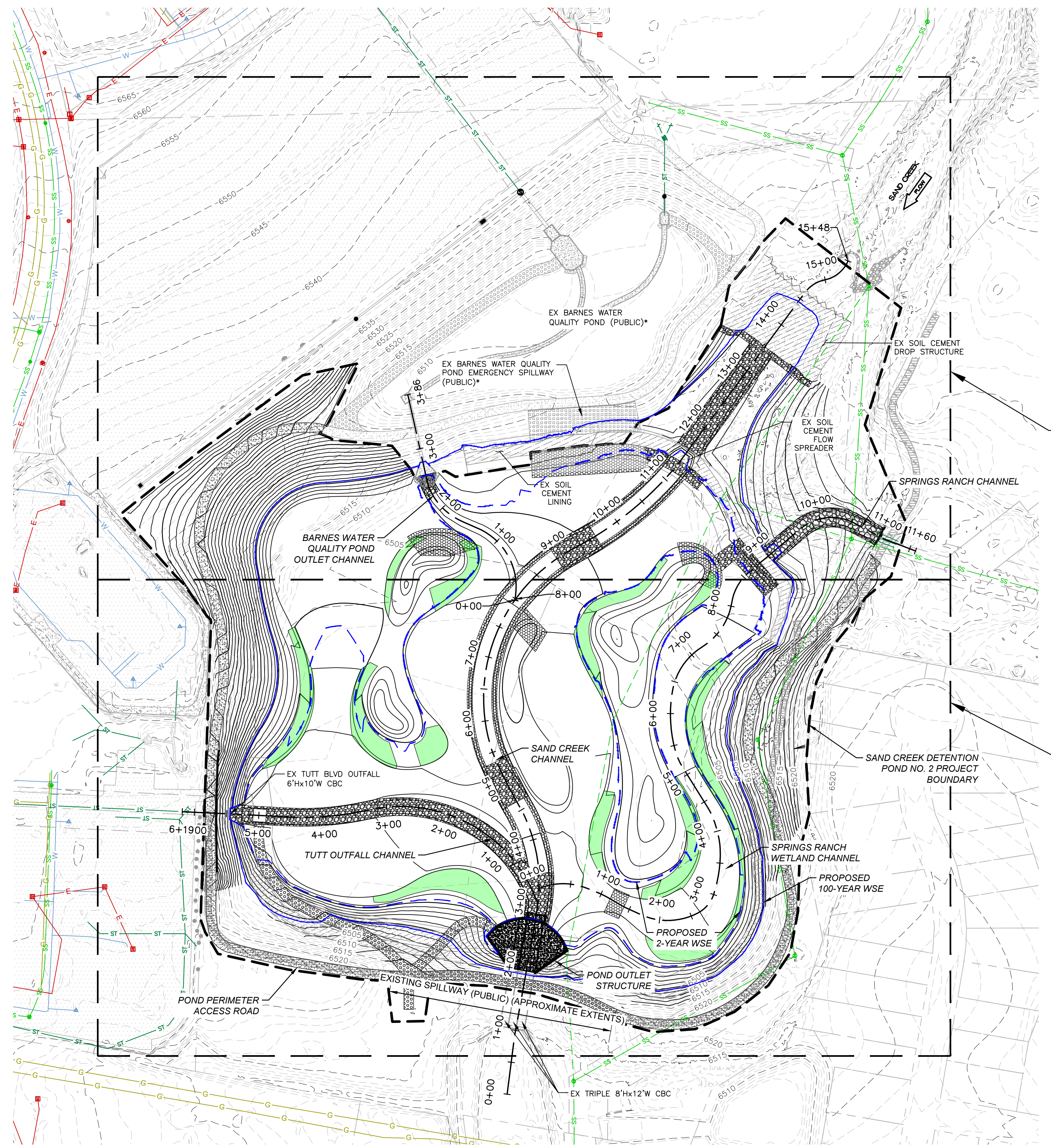

PLAN
 SCALE: 1" = 100'

**SAND CREEK POND NO. 2
 STAGE-STORAGE TABLE**

ELEVATION (FT)	AREA (AC)	STORAGE (AC-FT)	RELEASE RATE (CFS)
6499.6	0.0	0.0	0
6500	0.1	0.0	20
6501	0.3	0.2	150
6502	1.0	0.9	345
6503	2.9	2.8	375
6504	5.1	6.8	490
6505	7.3	13.0	815
6506	10.3	21.8	890
6507	11.6	32.7	955
6508	12.5	44.8	1025
6509	13.5	57.8	1150
6510	14.6	71.8	1265
6511	15.9	87.1	2895
6512	17.1	103.6	3680
6513	17.9	121.1	4000

DBPS 100-YR FLOW RATE = 2489 CFS

SEE DWG C-403 - GRADING PLAN (NORTH)

*THIS INFRASTRUCTURE ELEMENT IS PROPOSED AS PART OF THE BARNES WATER QUALITY POND PROJECT, WHICH IS TO BE COMPLETED BEFORE CONSTRUCTION OF SAND CREEK POND NO. 2 RESTORATION BEGINS.

SEE DWG C-402 - GRADING PLAN (SOUTH)

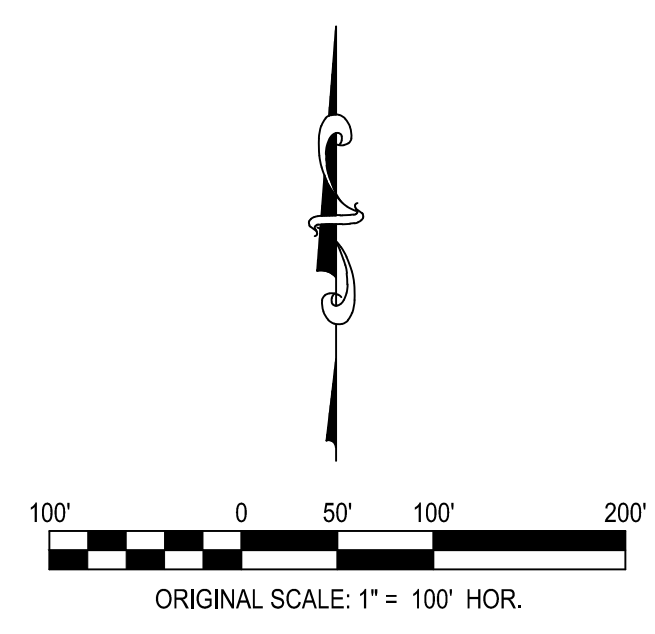

REV	REVISION DESCRIPTION	DATE	CHND	CHKD	APPR

CALL BEFORE YOU DIG

 Know what's below.
 Call before you dig.

CITY OF COLORADO SPRINGS
 30 S. NEVADA AVE., SUITE 401
 COLORADO SPRINGS, CO 80903
 (719) 385-5980

MERRICK
 Engineering | Architecture | Design-Build | Surveying | Planning | Geospatial Solutions
 2480 W. 26TH AVE., UNIT B225 - DENVER COLORADO 80211
 TEL. 303-751-0741, FAX 303-751-2581
 www.merrick.com

PE STAMP

 FOR AND ON BEHALF OF MERRICK & COMPANY

TITLE
SAND CREEK DETENTION POND NO. 2
 OVERALL GRADING PLAN AND KEY MAP

JOB NUMBER
 65420975
 DATE
 AUGUST 2024
 DWG
C-401
 SHEET
 8 of 51

THE NEW OR EXISTING ELEVATION INFORMATION IS AN INSTRUMENT OF SERVICE PROVIDED BY MERRICK & COMPANY, INC. FOR THE PROJECT. IT IS NOT INTENDED OR REPRESENTED TO BE SUITABLE FOR REUSE IN WHOLE OR IN PART OR FOR THE EXTENSION OF THE PROJECT OR FOR ANY OTHER PROJECT. REUSE OR MODIFICATION OF ANY INFORMATION NOT A PART OF THIS INSTRUMENT WITHOUT THE WRITTEN CONSENT OF MERRICK & COMPANY SHALL BE AT THE USER'S RISK. THE USER ASSUMES ALL LIABILITY FOR ANY SUCH REUSE OR MODIFICATION.

File Location: D:\Denver_North\Projects\City of Colorado Springs\Sand Creek Pond No. 2\CAD\CDS\0975-SITE_PLAN.dwg Pk1 Date: 8/26/2024 4:30 PM Last Saved By: TIM.MCMULLEN

MATCHLINE SEE DWG C-403

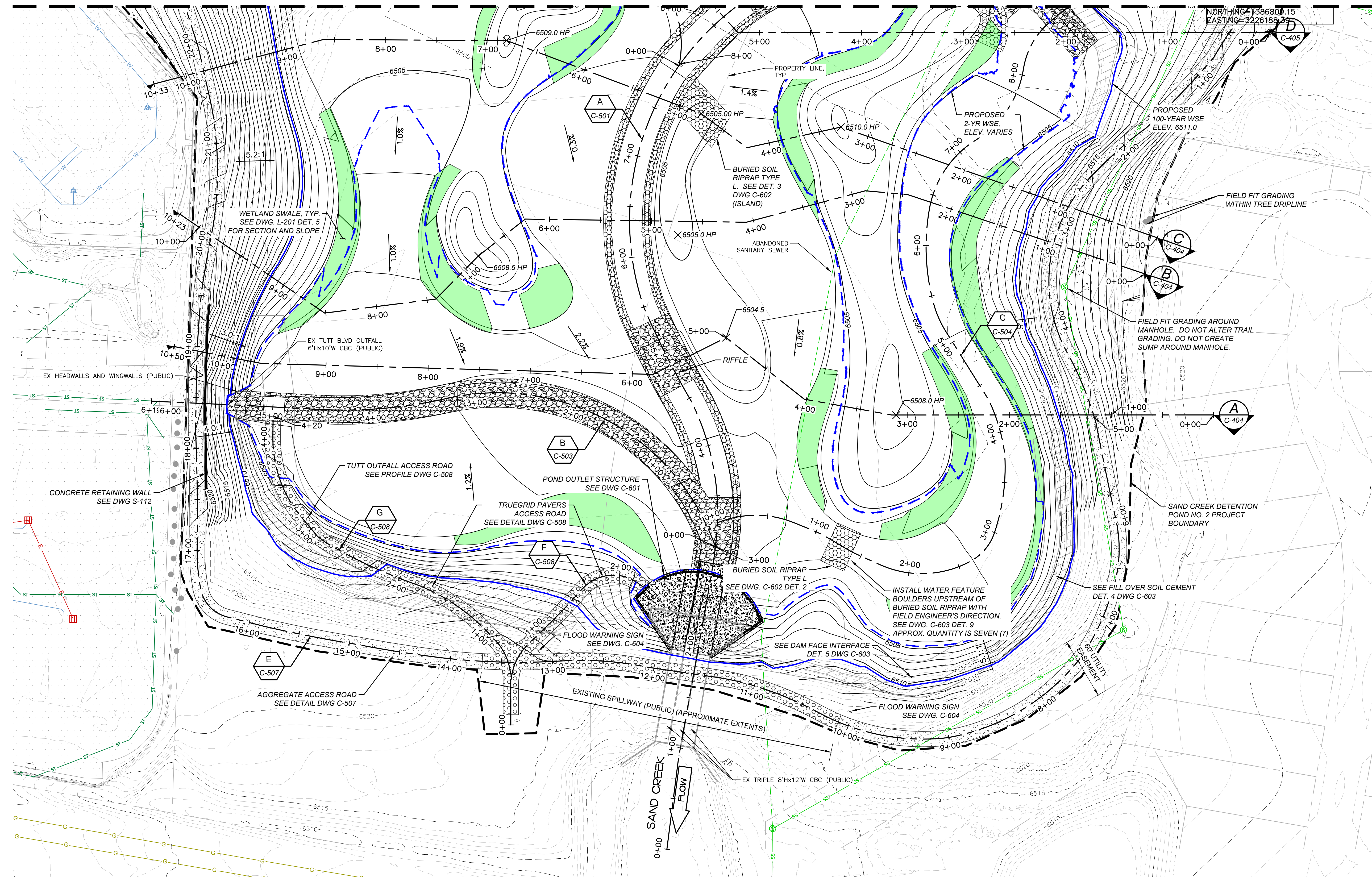

- NOTE:
- SEE LANDSCAPE SHEETS FOR PLANTING PLAN
 - SEE DWG C-603 FOR WATER FEATURE BOULDER DETAIL
 - SEE DWG C-602 FOR RIPRAP DETAILS

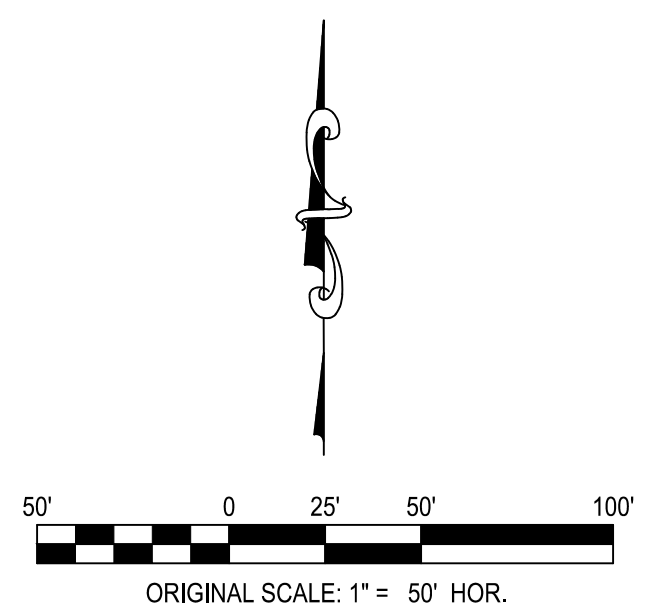

PLAN
SCALE: 1" = 50'

REV	REVISION DESCRIPTION	DATE	CHND	CHKD	APPR

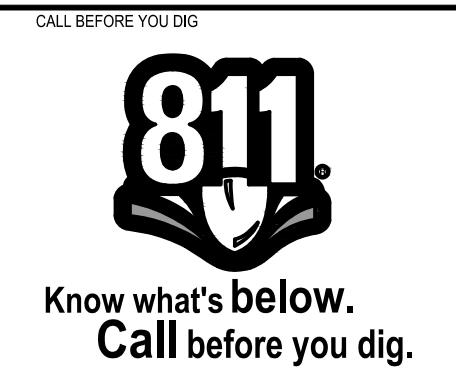

CITY OF COLORADO SPRINGS
 30 S. NEVADA AVE., SUITE 401
 COLORADO SPRINGS, CO 80903
 (719) 385-5980

MERRICK
 Engineering | Architecture | Design-Build | Surveying | Planning | Geospatial Solutions
 2480 W. 26TH AVE., UNIT B225 - DENVER COLORADO 80211
 TEL. 303-751-0741, FAX 303-751-2581
 www.merrick.com

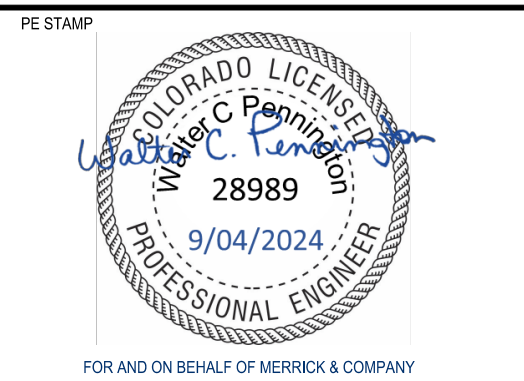

TITLE: **SAND CREEK DETENTION POND NO. 2**
GRADING PLAN (SOUTH)

JOB NUMBER	65420975
DATE	AUGUST 2024
DWG	C-402
SHEET	9 of 51

THE CITY OF COLORADO SPRINGS IS PROVIDING THIS INFORMATION AS AN INSTRUMENT OF SERVICE. SERVICES BY MERRICK AND COMPANY, INC. ARE THE PROPERTY OF MERRICK AND COMPANY, INC. AND ARE NOT TO BE REPRODUCED OR TRANSMITTED IN ANY FORM OR BY ANY MEANS, ELECTRONIC OR MECHANICAL, INCLUDING PHOTOCOPYING, RECORDING, OR BY ANY INFORMATION STORAGE AND RETRIEVAL SYSTEM, WITHOUT THE PRIOR WRITTEN PERMISSION OF MERRICK AND COMPANY, INC. THIS INFORMATION IS PROVIDED AS IS AND WITHOUT WARRANTY OF ANY KIND, INCLUDING MERCHANTABILITY AND FITNESS FOR A PARTICULAR PURPOSE. THE USER SHALL BE RESPONSIBLE FOR OBTAINING NECESSARY PERMITS AND APPROVALS FROM THE APPROPRIATE AGENCIES.

File Location: D:\Denver_North\Projects\City of Colorado Springs\Sand Creek Pond No. 2\CAD\CDS\0975-SITE_PLAN.dwg Pklt Date: 9/4/2024 10:59 AM Last Saved By: TIM.MCKMULLEN

NOTE: DO NOT FILL OVER SOIL CEMENT. CONTACT OWNER'S REPRESENTATIVE IF EX. SOIL CEMENT IS 0.5' LOWER THAN PROPOSED GRADE.

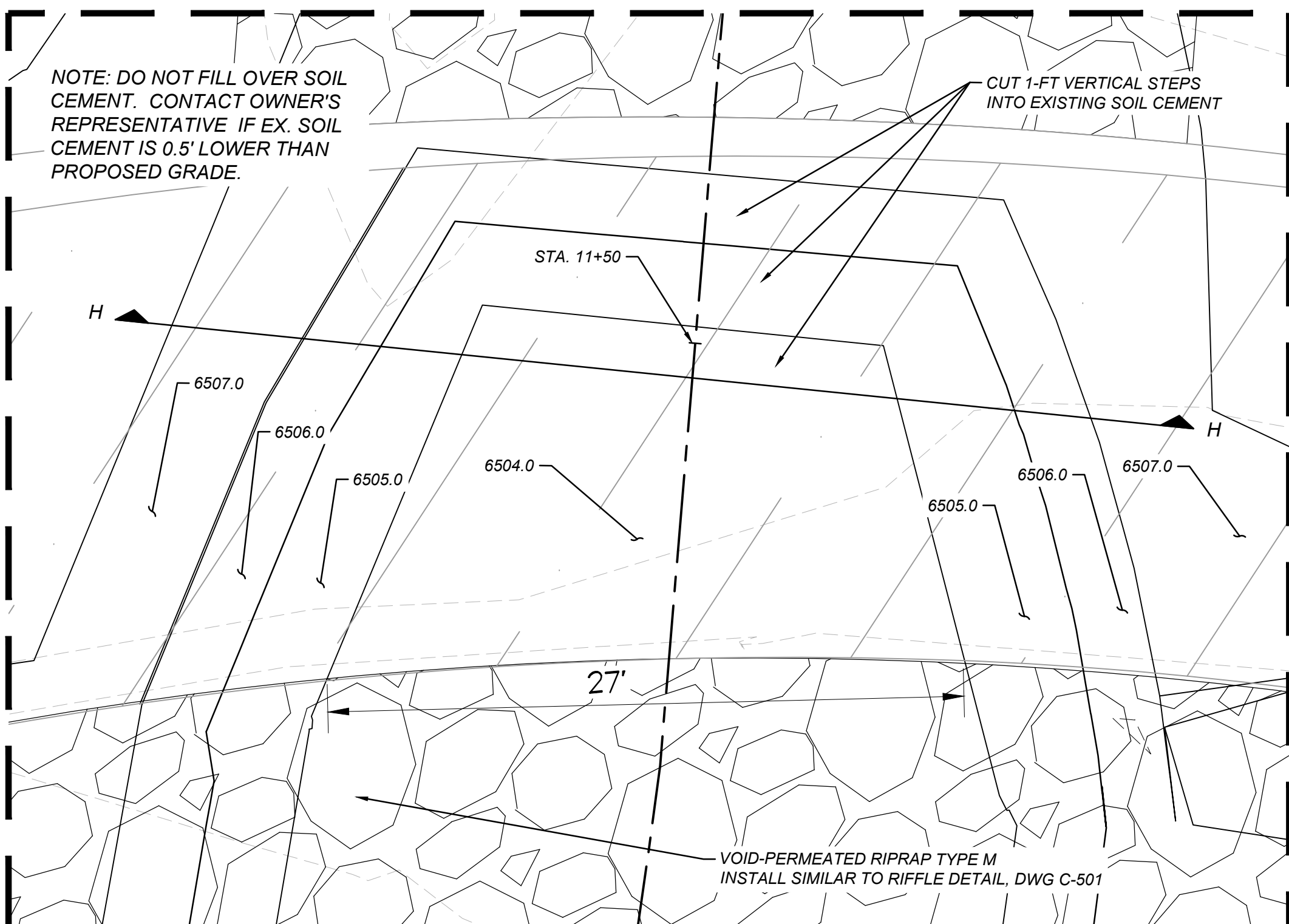

SOIL CEMENT MODIFICATION PLAN ENLARGEMENT
SCALE: 1" = 5'

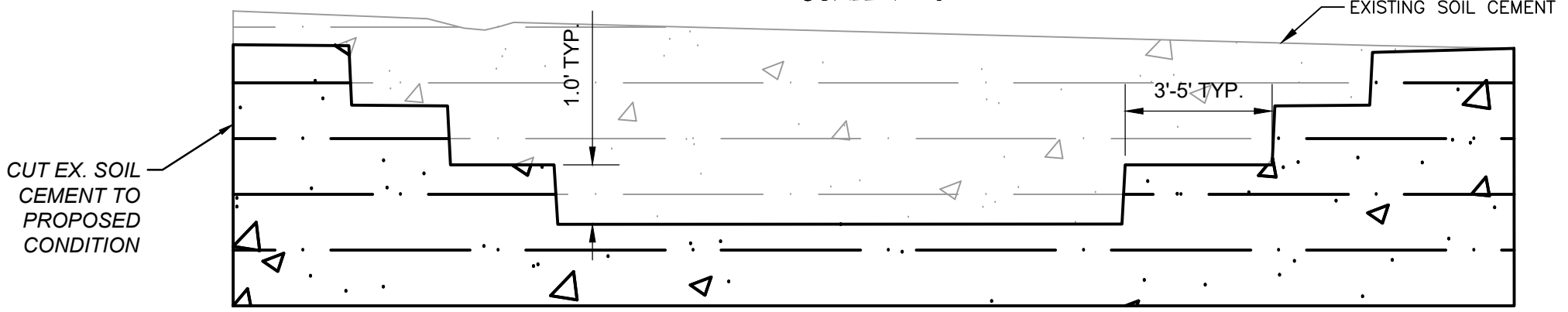

SOIL CEMENT MODIFICATION SECTION H-H (NTS)

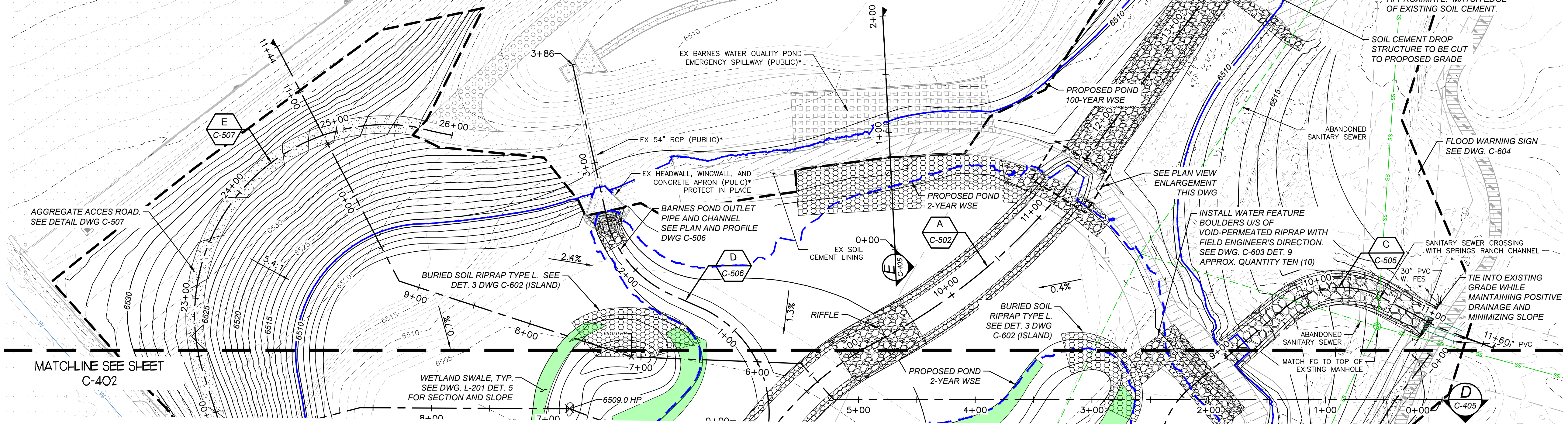
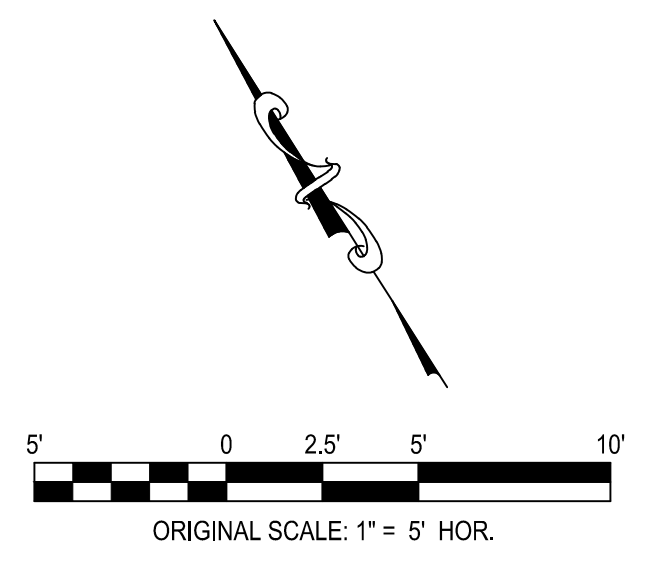

PLAN
SCALE: 1" = 50'

- NOTE:
1. SEE LANDSCAPE SHEETS FOR PLANTING PLAN
 2. SEE DWG C-603 FOR WATER FEATURE BOULDER DETAIL
 3. SEE DWG C-602 FOR RIPRAP DETAILS

*THIS INFRASTRUCTURE ELEMENT IS PROPOSED AS PART OF THE BARNES WATER QUALITY POND PROJECT, WHICH IS TO BE COMPLETED BEFORE CONSTRUCTION OF SAND CREEK POND NO. 2 RESTORATION BEGINS.

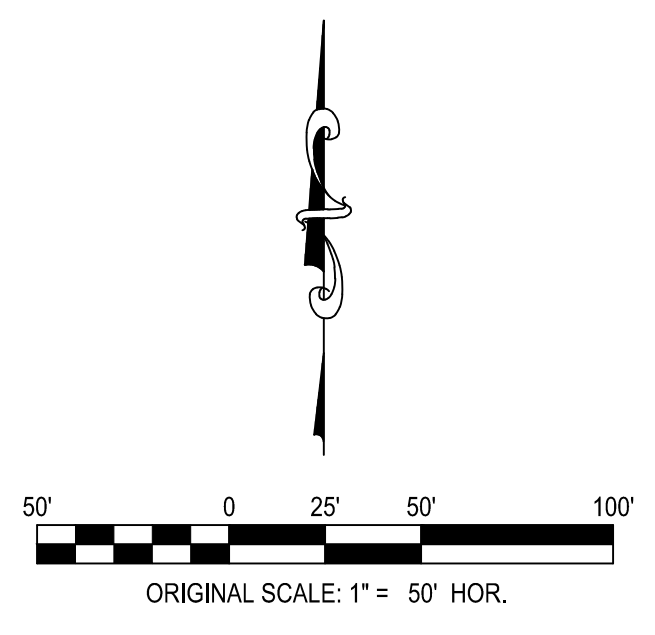

REV	REVISION DESCRIPTION	DATE	CHND	CHKD	APPR

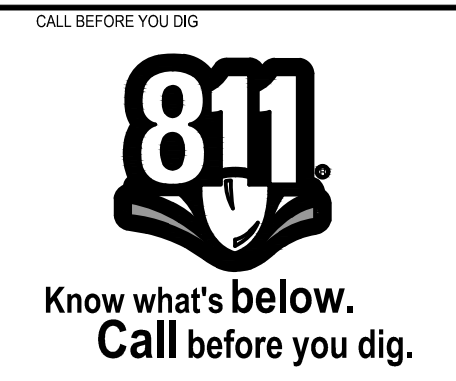

CITY OF COLORADO SPRINGS
30 S. NEVADA AVE., SUITE 401
COLORADO SPRINGS, CO 80903
(719) 385-5980

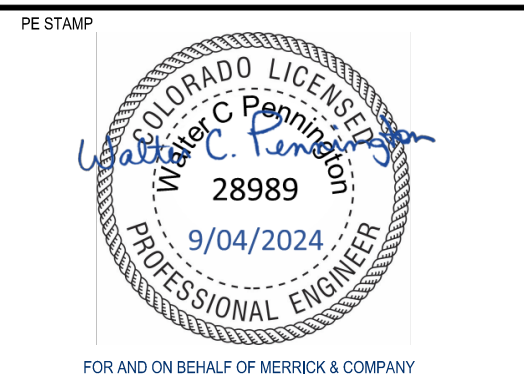

TITLE
SAND CREEK DETENTION POND NO. 2
GRADING PLAN (NORTH)

JOB NUMBER	65420975
DATE	AUGUST 2024
DWG	C-403
SHEET	10 of 51

THE CITY OF COLORADO SPRINGS HAS REVIEWED THIS INSTRUMENT OF SERVICE PREPARED BY MERRICK AND COMPANY FOR A SERVICE PROJECT. IT IS NOT INTENDED OR REPRESENTED TO BE A SUBSTITUTE FOR A PROFESSIONAL ENGINEER'S DESIGN OR FOR ANY OTHER PROJECT. REUSE OR MODIFICATION OF ANY INSTRUMENT WITHOUT THE WRITTEN CONSENT OF THE PROJECTOR OR ANOTHER PARTY IS PROHIBITED. MERRICK AND COMPANY SHALL BE AT THE SOLE RISK FOR THE QUALITY OF THE SERVICE PROVIDED TO THE CLIENT.

File Location: D:\Denver_North\Projects\City of Colorado Springs\Sand Creek Pond No 2\CAD\CDS\0975-SITE_PLAN.dwg Pk1 Date: 8/26/2024 4:31 PM Last Saved By: TIM.MCMULLEN

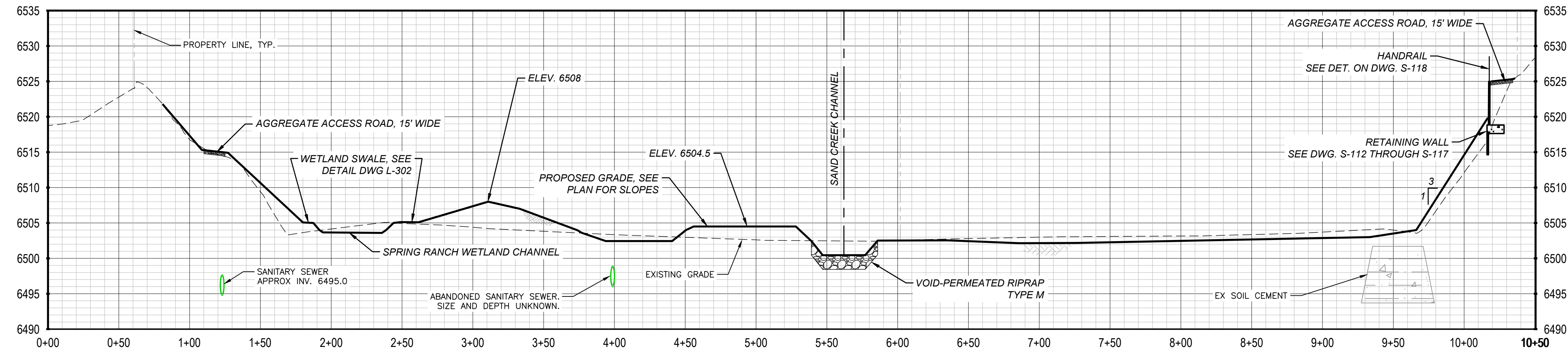

SECTION A
 HOR. SCALE 1" = 50'
 VER. SCALE 1" = 10'

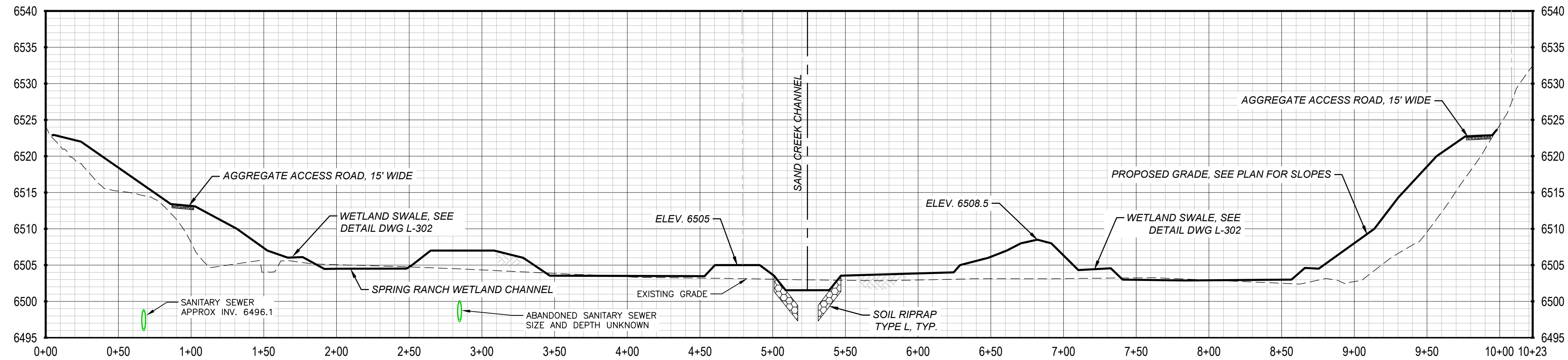

SECTION B
 HOR. SCALE 1" = 50'
 VER. SCALE 1" = 10'

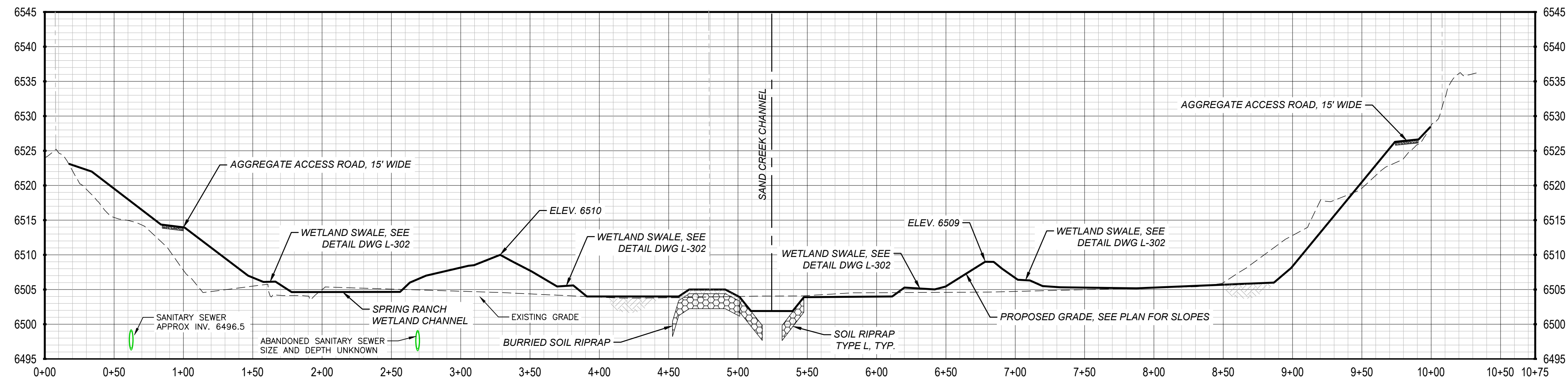

SECTION C
 HOR. SCALE 1" = 50'
 VER. SCALE 1" = 10'

ALL SECTIONS LOOKING DOWNSTREAM

REV	REVISION DESCRIPTION	DATE	CHND	CHKD	APPR



CITY OF COLORADO SPRINGS
 30 S. NEVADA AVE., SUITE 401
 COLORADO SPRINGS, CO 80903
 (719) 385-5980

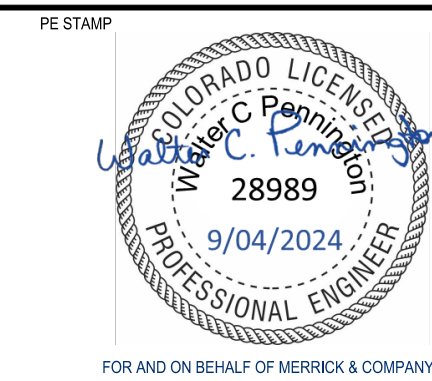

SAND CREEK DETENTION POND NO. 2

POND SECTIONS

JOB NUMBER	65420975
DATE	AUGUST 2024
DWG	C-404
SHEET	11 of 51

THE CITY OF COLORADO SPRINGS IS PROVIDING THIS INFORMATION AS AN INSTRUMENT OF SERVICE. SERVICES BY MERRICK AND COMPANY, INC. ARE PROVIDED AS PART OF THE INSTRUMENT OF SERVICE. MERRICK AND COMPANY, INC. IS NOT PROVIDING ANY GUARANTEE OR WARRANTY FOR THE PROJECT. REUSE OR MODIFICATION OF ANY INFORMATION NOT A PART OF THE INSTRUMENT OF SERVICE WITHOUT THE WRITTEN CONSENT OF MERRICK AND COMPANY, INC. SHALL BE AT THE USER'S RISK. THE USER SHALL BE RESPONSIBLE FOR OBTAINING ALL NECESSARY PERMITS AND APPROVALS.

File Location: D:\Denver_North\Projects\City of Colorado Springs\Sand Creek Pond No. 2\CAD\09\0975-SITE_PLAN.dwg Pk1 Date: 8/26/2024 4:31 PM Last Saved By: TIM.MCMULLEN

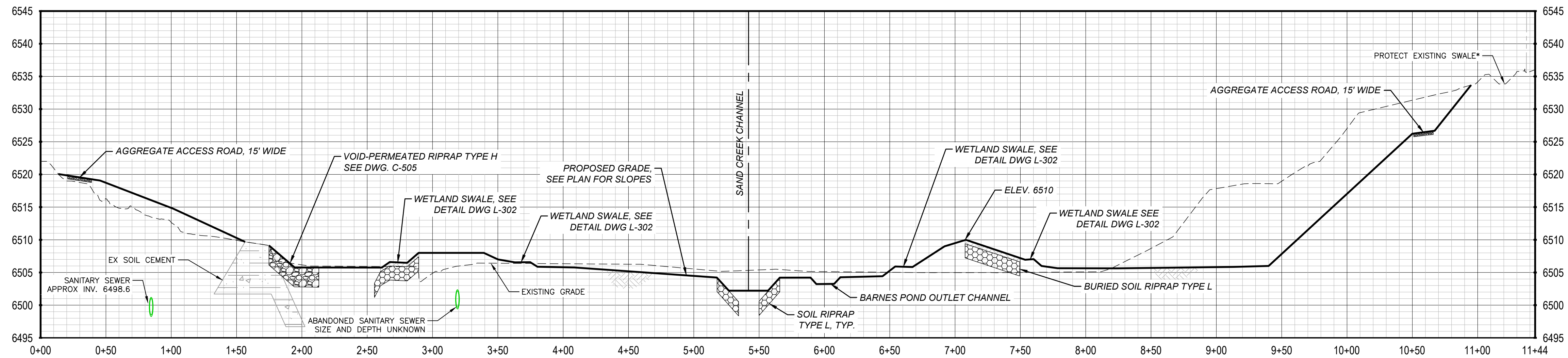

SECTION D
 HOR. SCALE: 1" = 50'
 VER. SCALE: 1" = 10'

*THIS INFRASTRUCTURE ELEMENT IS PROPOSED AS PART OF THE BARNES WATER QUALITY POND PROJECT, WHICH IS TO BE COMPLETED BEFORE CONSTRUCTION OF SAND CREEK POND NO. 2 RESTORATION BEGINS.

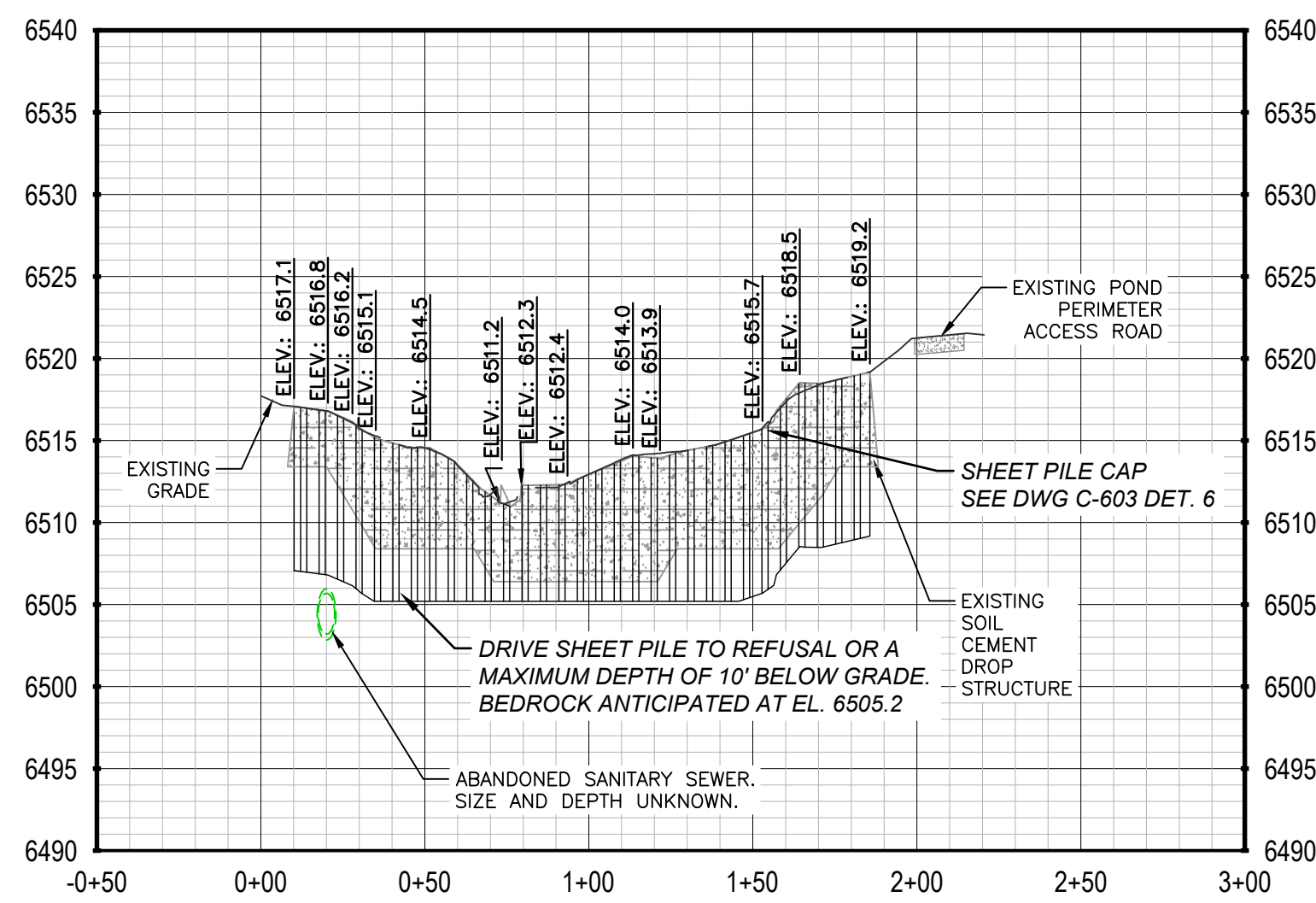

SECTION F
 HOR. SCALE: 1" = 30'
 VER. SCALE: 1" = 5'

NOTE: CREST ELEVATIONS ARE APPROXIMATE. MATCH EXISTING GRADE.

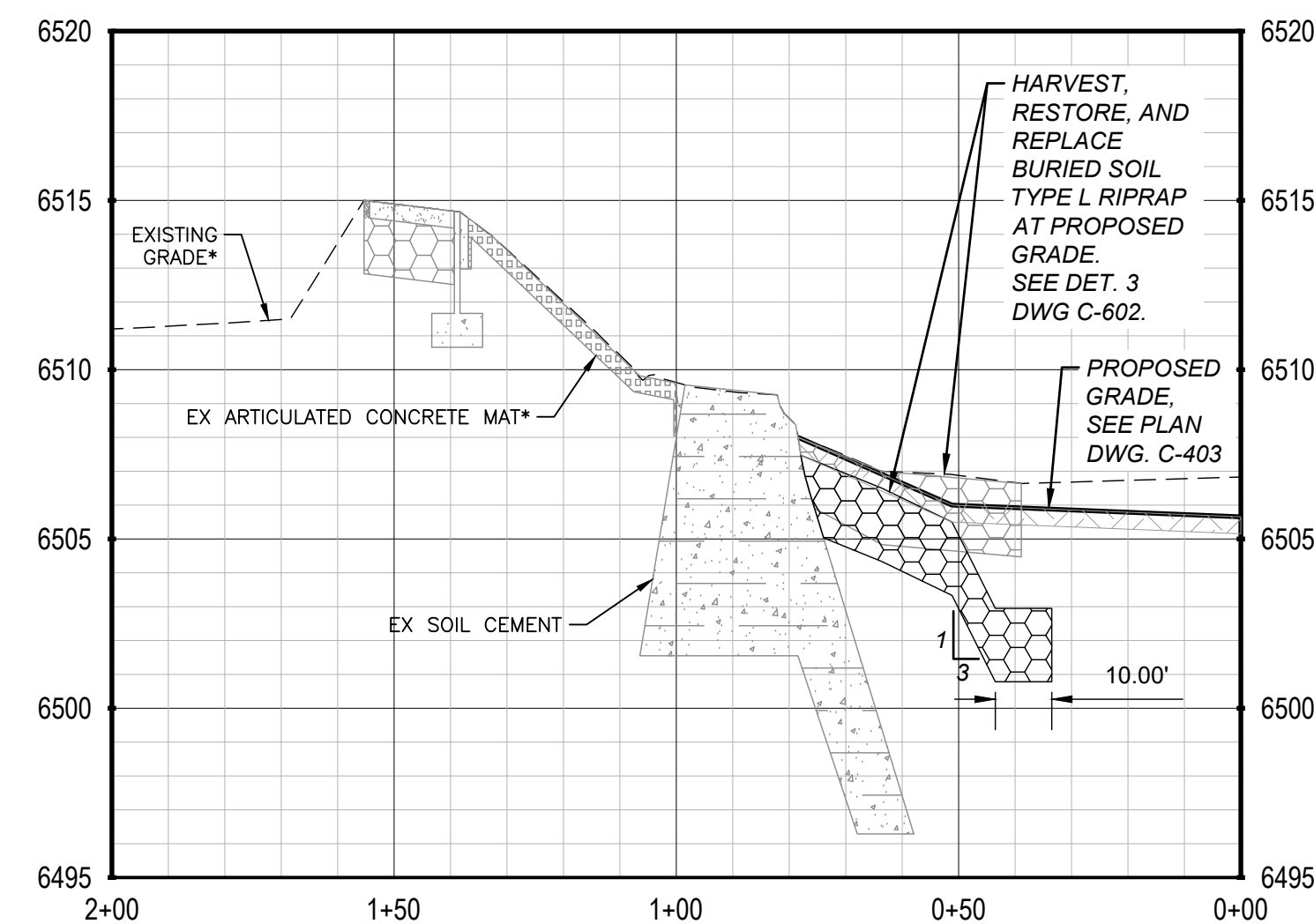

SECTION E
 HOR. SCALE: 1" = 30'
 VER. SCALE: 1" = 5'

REV	REVISION DESCRIPTION	DATE	CHND	CHKD	APPR



CITY OF COLORADO SPRINGS
 30 S. NEVADA AVE., SUITE 401
 COLORADO SPRINGS, CO 80903
 (719) 385-5980

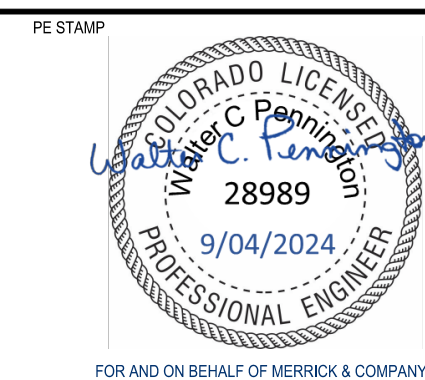

SAND CREEK DETENTION POND NO. 2

POND SECTIONS

JOB NUMBER	65420975
DATE	AUGUST 2024
DWG	C-405
SHEET	12 of 51

THE CITY OF COLORADO SPRINGS IS PROVIDING THIS INFORMATION AS AN INSTRUMENT OF SERVICE. SERVICES BY MERRICK AND COMPANY, INC. ARE FOR THE PROJECT. REUSE OR MODIFICATION OF ANY INFORMATION OR REPRESENTATION IS AT THE USER'S RISK. MERRICK AND COMPANY, INC. DOES NOT WARRANT THE ACCURACY OF ANY INFORMATION OR REPRESENTATION. WITHOUT THE WRITTEN CONSENT OF MERRICK AND COMPANY, NO PART OF THIS DRAWING SHALL BE REPRODUCED OR TRANSMITTED IN ANY FORM OR BY ANY MEANS, ELECTRONIC OR MECHANICAL, INCLUDING PHOTOCOPYING, RECORDING, OR BY ANY INFORMATION STORAGE AND RETRIEVAL SYSTEM.

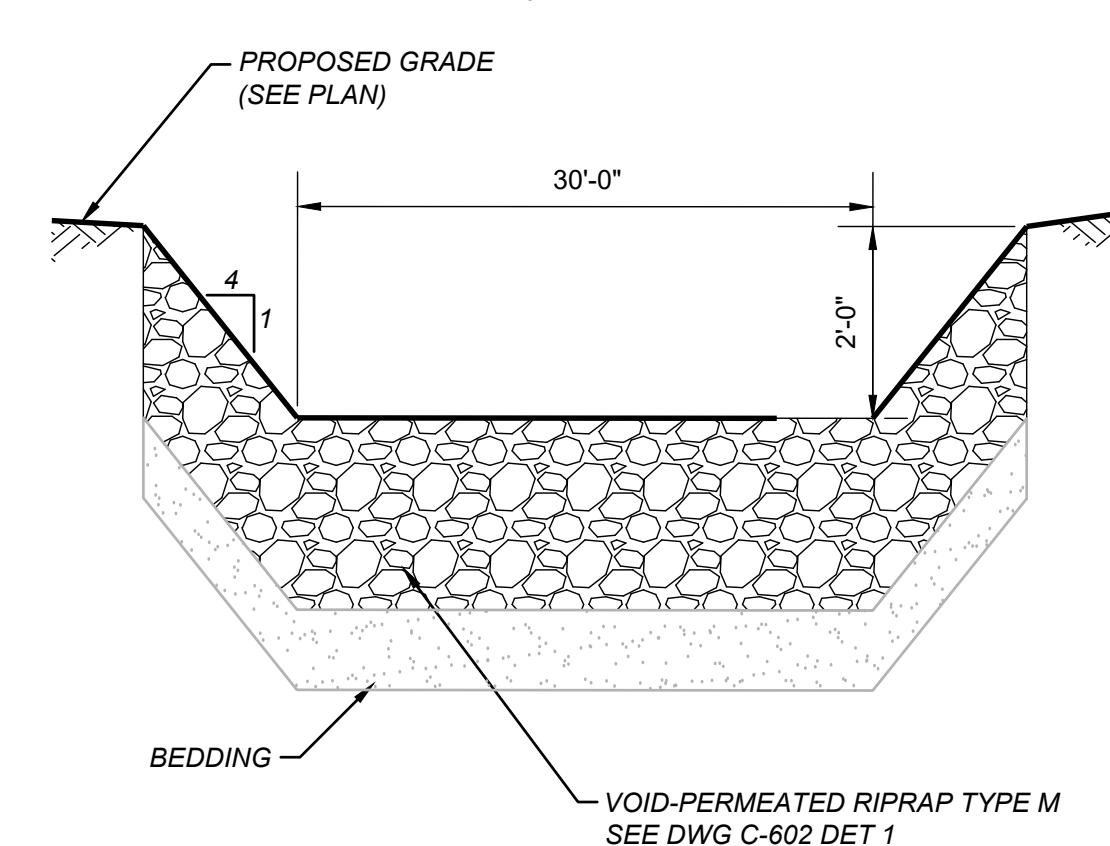
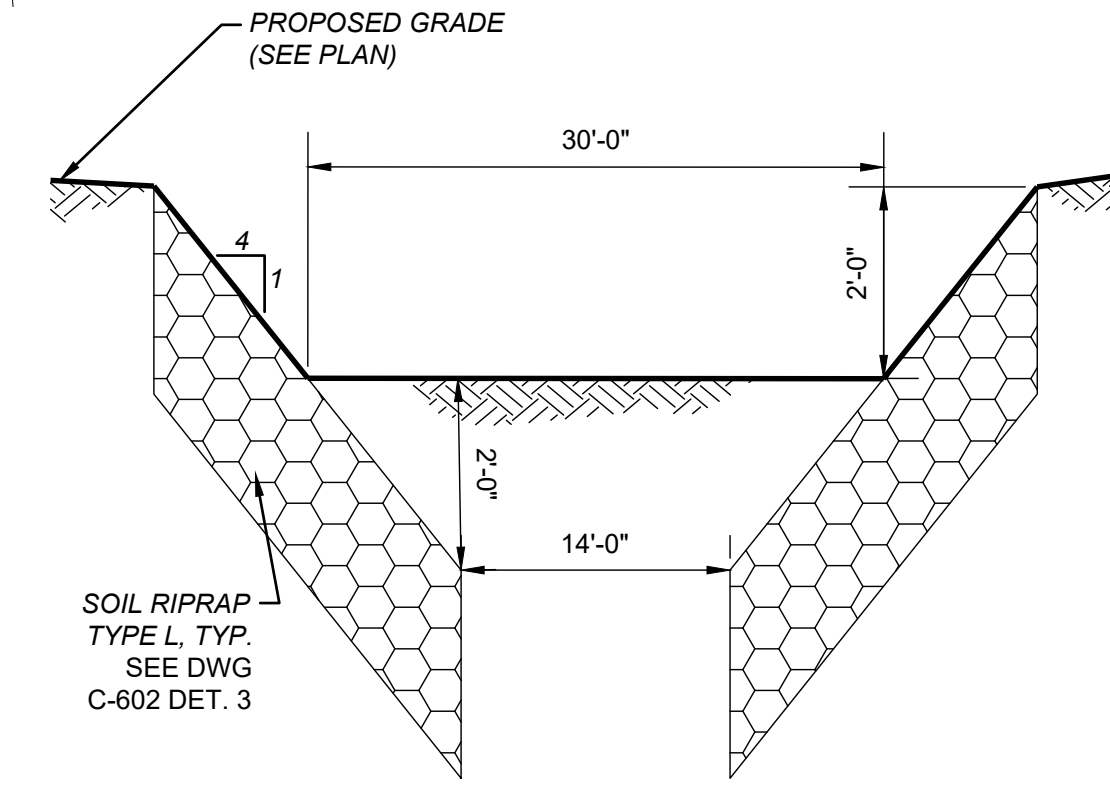
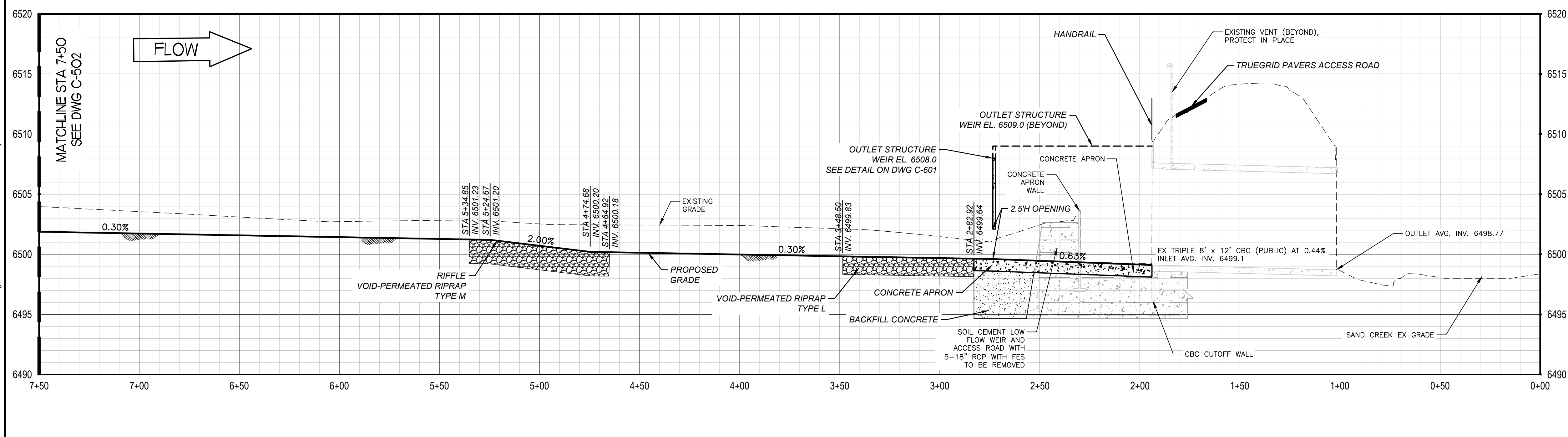
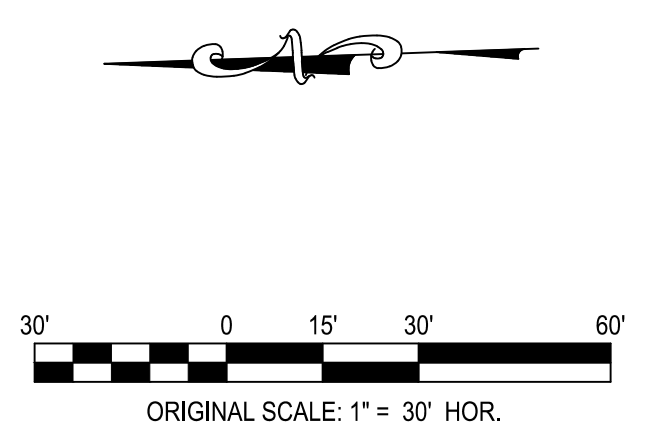
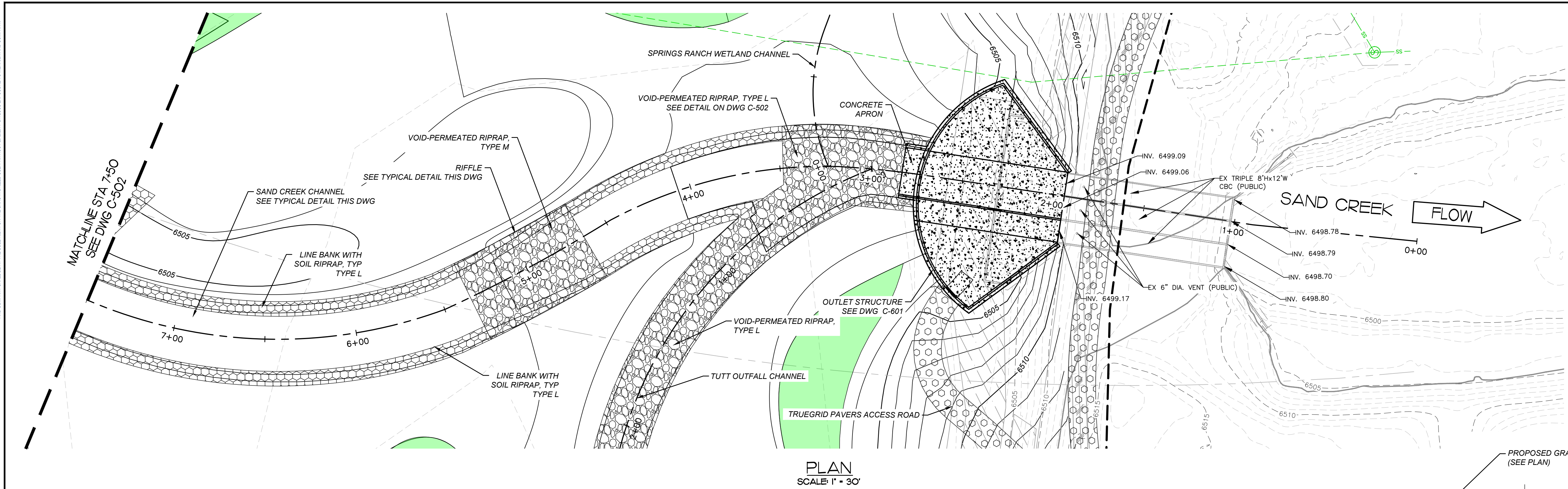

REV	REVISION DESCRIPTION	DATE	CHND	CHKD	APPR



CITY OF COLORADO SPRINGS
 30 S. NEVADA AVE., SUITE 401
 COLORADO SPRINGS, CO 80903
 (719) 385-5980



SAND CREEK DETENTION POND NO. 2
SAND CREEK CHANNEL PLAN & PROFILE
 STA 0+00 TO STA. 7+50

JOB NUMBER	65420975
DATE	AUGUST 2024
DWG	C-501
SHEET	13 of 51

THE NEW SAND CREEK DETENTION POND CONSTRUCTION IS AN INSTRUMENT OF SERVICE PROVIDED BY MERRICK & COMPANY, P.C. A SERVICE PROJECT. IT IS NOT INTENDED OR REPRESENTED TO BE A FINAL DESIGN OR PART OF THE DESIGN OF THE PROJECT OR ON ANY OTHER PROJECT. REUSE OR MODIFICATION OF ANY INFORMATION NOT A PART OF THE INSTRUMENT OF SERVICE WITHOUT THE WRITTEN CONSENT OF MERRICK & COMPANY SHALL BE AT THE USER'S RISK. THE USER SHALL BE RESPONSIBLE FOR OBTAINING ALL NECESSARY PERMITS AND APPROVALS.

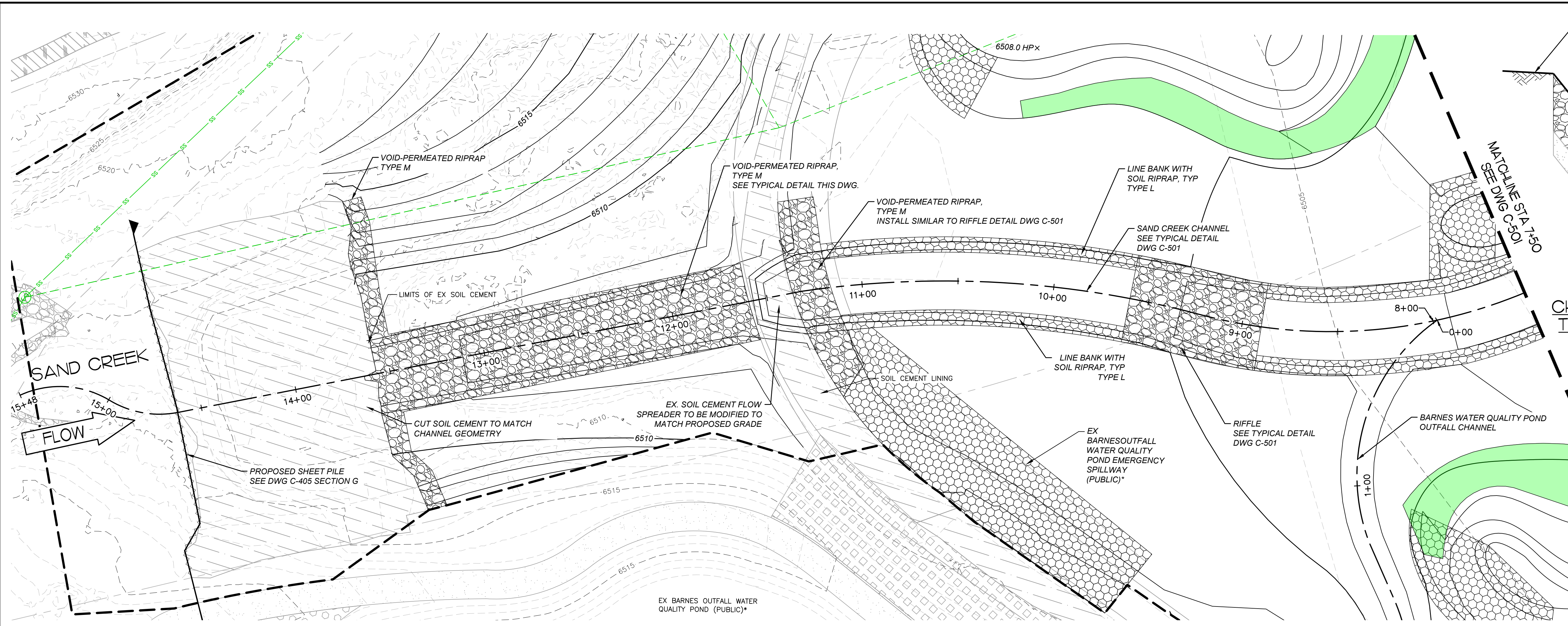

TYPICAL SAND CREEK CHANNEL SECTION STA. 2+83 TO 3+49 AND 11+58 TO 13+68
 HOR. SCALE: 1" = 10'
 VER. SCALE: 1" = 2'

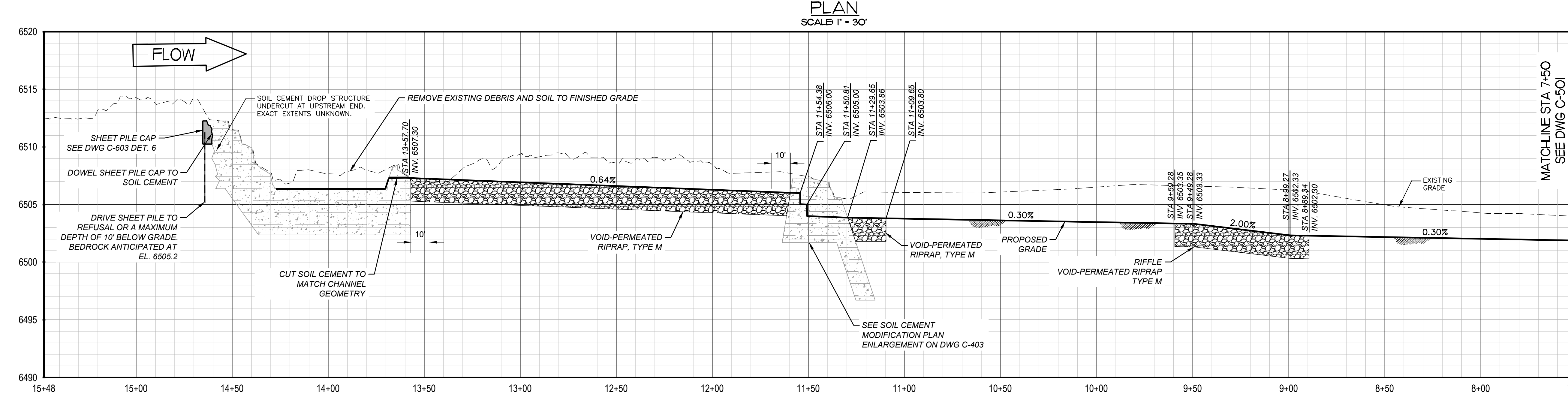
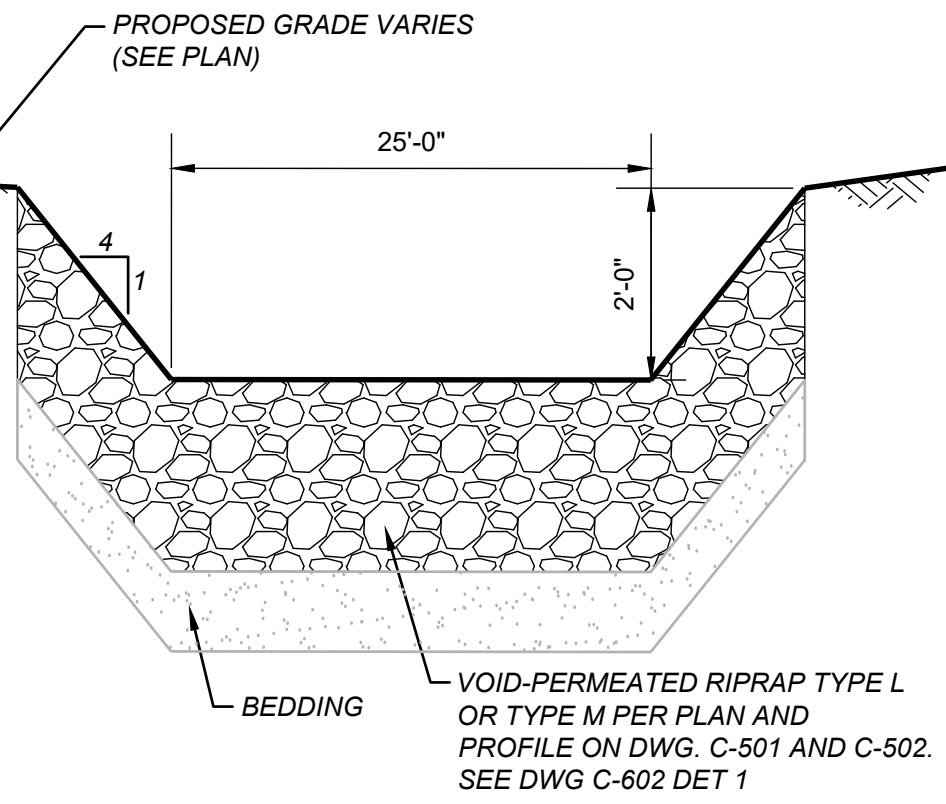

A PROFILE
 C-502 HOR. SCALE: 1" = 30'
 VER. SCALE: 1" = 5'



*THIS INFRASTRUCTURE ELEMENT IS PROPOSED AS PART OF THE BARNES WATER QUALITY POND PROJECT, WHICH IS TO BE COMPLETED BEFORE CONSTRUCTION OF SAND CREEK POND NO. 2 RESTORATION BEGINS.

File Location: D:\Denver_North\Projects\City of Colorado Springs\Sand Creek Pond No. 2\CAD\C502\0975-P&P.dwg Plot Date: 8/26/2024 4:33 PM Last Saved By: TIM.MCMULLEN R24-1285

REV	REVISION DESCRIPTION	DATE	CHND	CHKD	APPR

CALL BEFORE YOU DIG

Know what's below.
Call before you dig.

CITY OF COLORADO SPRINGS
 30 S. NEVADA AVE., SUITE 401
 COLORADO SPRINGS, CO 80903
 (719) 385-5980

MERRICK
 Engineering | Architecture | Design-Build | Surveying | Planning | Geospatial Solutions
 2480 W. 26TH AVE., UNIT B225 - DENVER COLORADO 80211
 TEL. 303-751-0741, FAX 303-751-2581
 www.merrick.com

PE STAMP

FOR AND ON BEHALF OF MERRICK & COMPANY

SAND CREEK DETENTION POND NO. 2
SAND CREEK CHANNEL PLAN & PROFILE
 STA. 7+50 TO STA. 15+45

JOB NUMBER: 65420975
 DATE: AUGUST 2024
 DWG: **C-502**
 SHEET: 14 of 51

THE CITY OF COLORADO SPRINGS IS PROVIDING THIS INFORMATION AS AN INSTRUMENT OF SERVICE. MERRICK & COMPANY, INC. IS THE ENGINEER OF RECORD FOR THIS PROJECT. IT IS NOT INTENDED OR REPRESENTED TO BE SUITABLE FOR REUSE OR FOR REUSE IN WHOLE OR IN PART FOR ANY OTHER PROJECT. REUSE OR MODIFICATION OF ANY INFORMATION NOT A PART OF THIS INSTRUMENT OF SERVICE WITHOUT THE WRITTEN CONSENT OF MERRICK & COMPANY SHALL BE AT THE USER'S RISK. THE USER SHALL BE RESPONSIBLE FOR OBTAINING ALL NECESSARY PERMITS AND APPROVALS FROM ALL APPLICABLE AGENCIES.

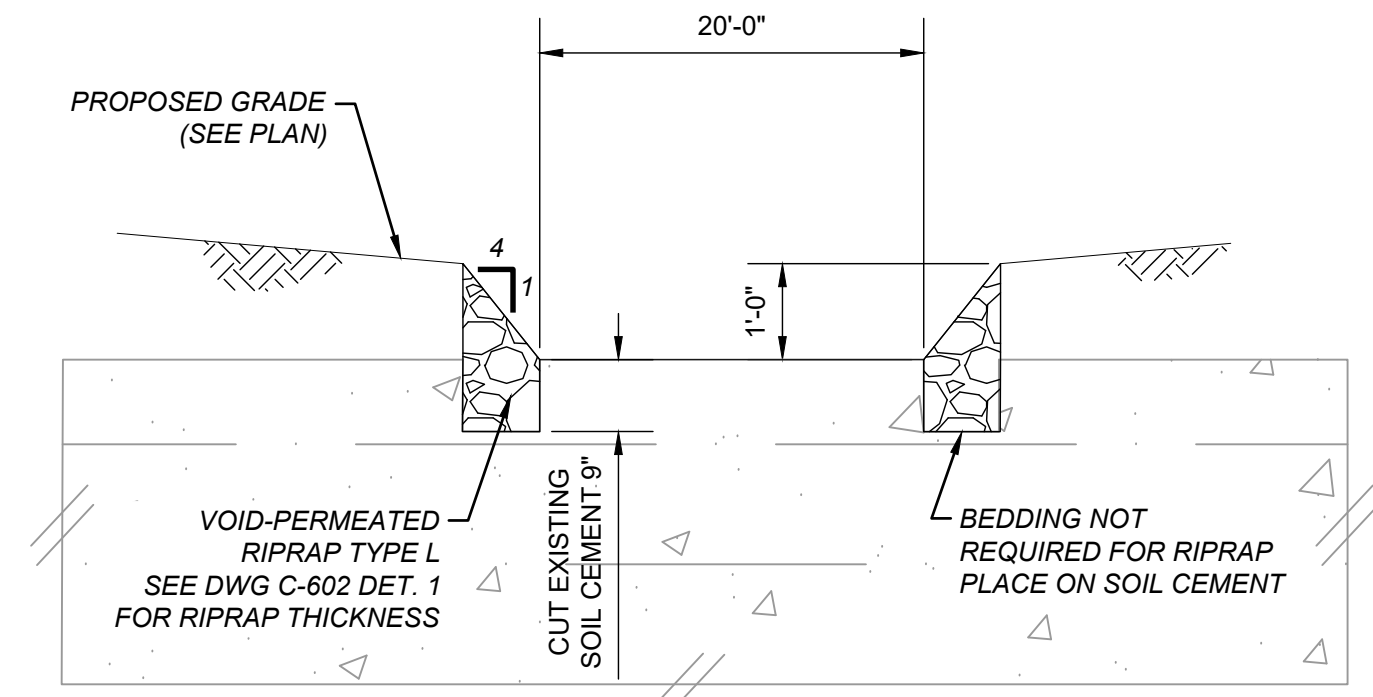
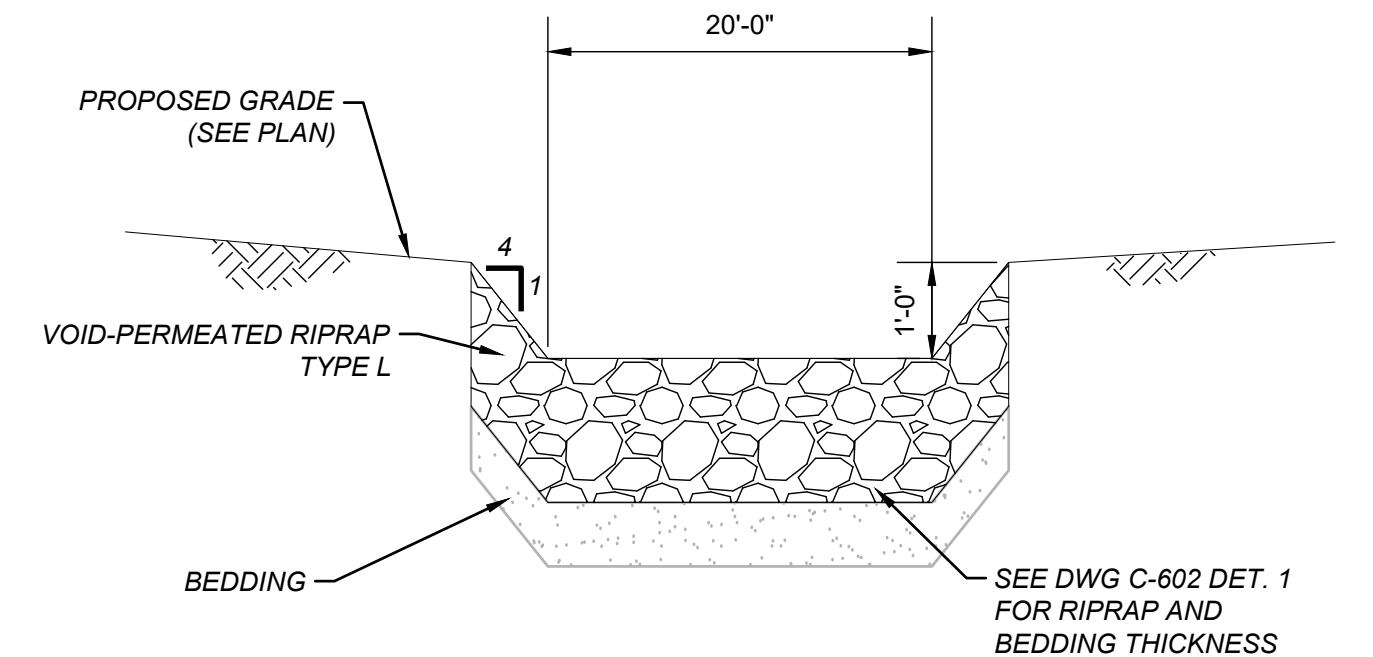
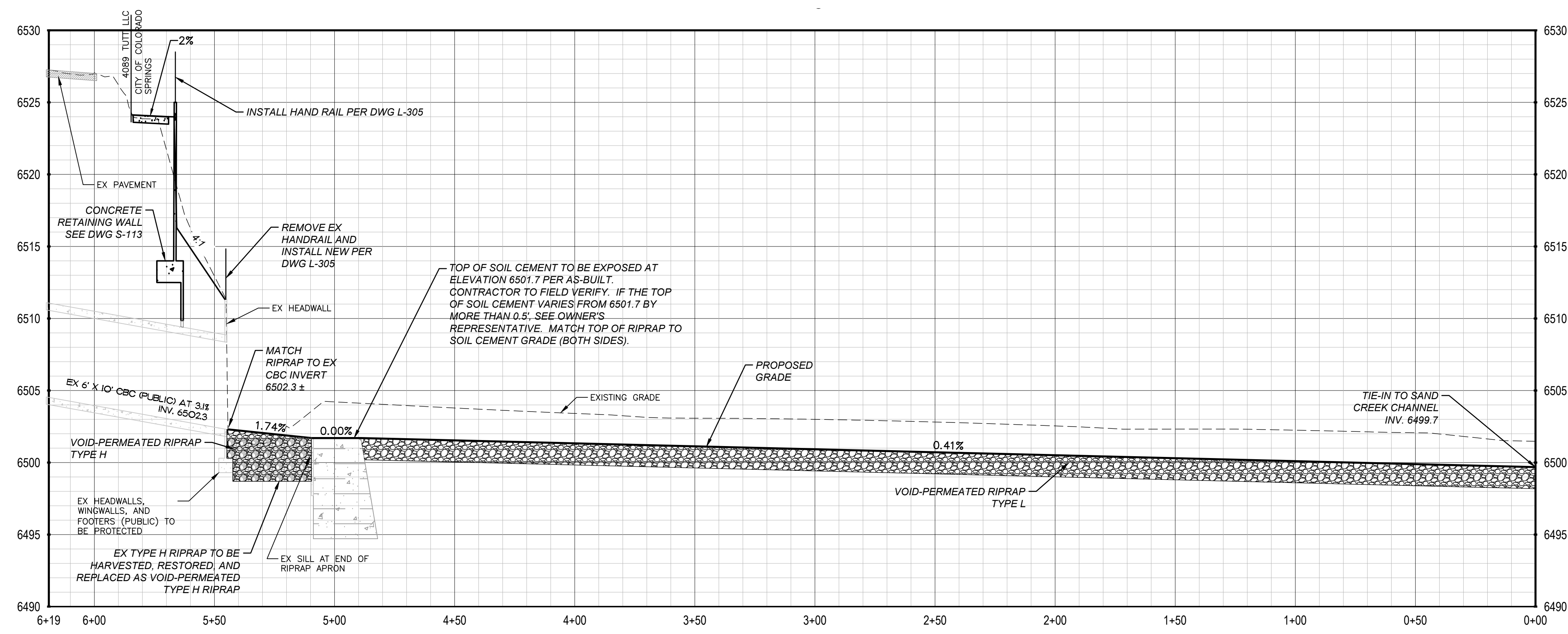
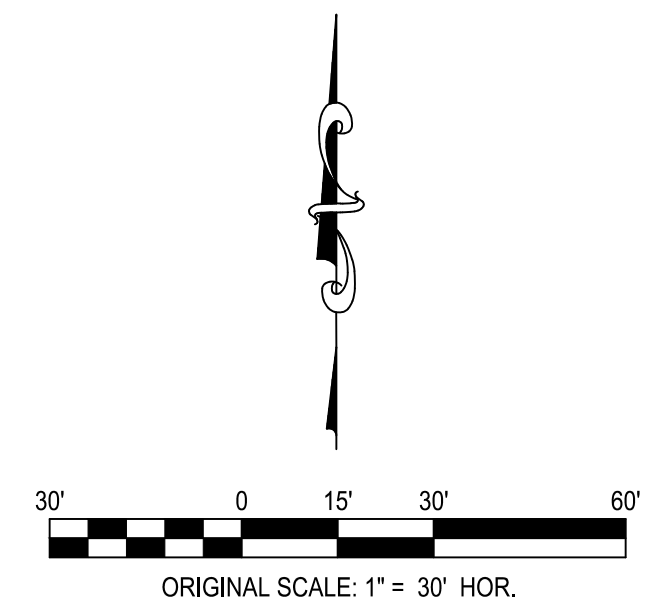
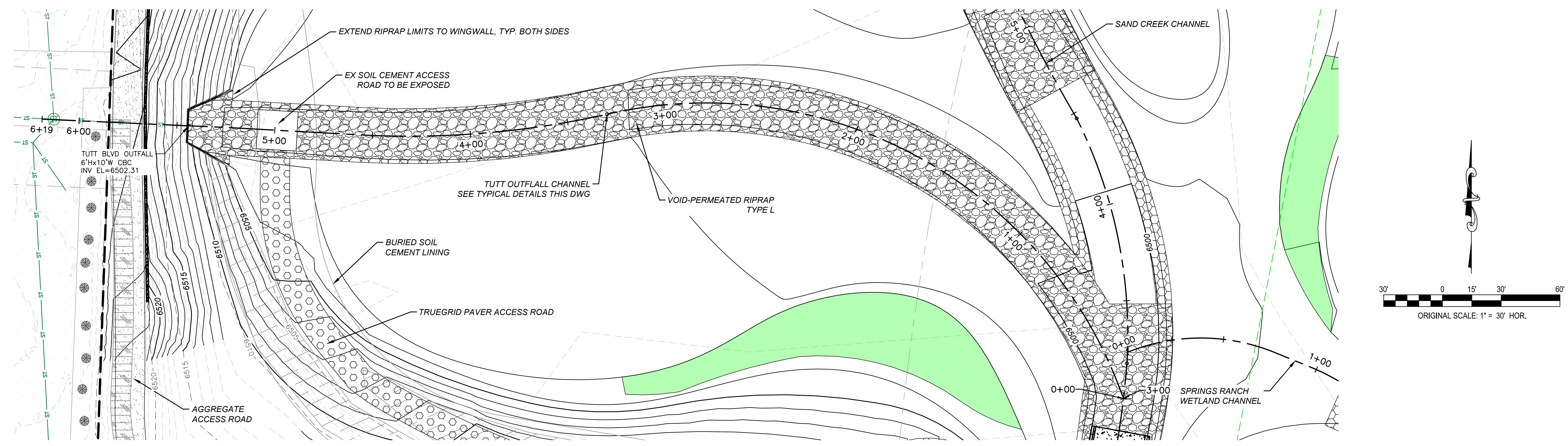

File Location: D:\Denver_North\Projects\City of Colorado Springs\Sand Creek Pond No. 2\CAD\CDS\0975-Tutt-P&P.dwg Plot Date: 8/26/2024 4:34 PM Last Saved By: TIM.MCMULLEN

REV	REVISION DESCRIPTION	DATE	CHND	CHKD	APPR

CALL BEFORE YOU DIG

 Know what's below.
 Call before you dig.

CITY OF COLORADO SPRINGS
 30 S. NEVADA AVE., SUITE 401
 COLORADO SPRINGS, CO 80903
 (719) 385-5980

Engineering | Architecture | Design-Build | Surveying | Planning | Geospatial Solutions
 2480 W. 26TH AVE., UNIT B225 - DENVER COLORADO 80211
 TEL. 303-751-0741, FAX 303-751-2581
 www.merrick.com

PE STAMP

 FOR AND ON BEHALF OF MERRICK & COMPANY

TITLE
 SAND CREEK DETENTION POND NO. 2
 TUTT OUTFALL PLAN AND PROFILE

JOB NUMBER: 65420975
 DATE: AUGUST 2024
 DWG: C-503
 SHEET: 15 of 51

THE CITY OF COLORADO SPRINGS HAS REVIEWED THIS PLAN FOR CONFORMANCE WITH THE CITY ENGINEERING DEPARTMENT'S STANDARDS AND SPECIFICATIONS FOR WETLANDS AND CHANNELS. THIS REVIEW IS LIMITED TO THE TECHNICAL ASPECTS OF THE PLAN AND DOES NOT CONSTITUTE AN ENDORSEMENT OF THE PROJECT OR AN ASSURANCE OF THE ACCURACY OF THE INFORMATION PROVIDED. THE CITY ENGINEERING DEPARTMENT IS NOT RESPONSIBLE FOR THE DESIGN OR CONSTRUCTION OF THE PROJECT OR FOR ANY DAMAGE TO PERSONS OR PROPERTY THAT MAY OCCUR AS A RESULT OF THE PROJECT. THE CITY ENGINEERING DEPARTMENT IS NOT RESPONSIBLE FOR THE DESIGN OR CONSTRUCTION OF THE PROJECT OR FOR ANY DAMAGE TO PERSONS OR PROPERTY THAT MAY OCCUR AS A RESULT OF THE PROJECT.

File Location: D:\Denver_North\Projects\City of Colorado Springs\Sand Creek Pond No. 2\CAD\03\0975-SPRING_RANCH_P&P.dwg Plot Date: 8/26/2024 4:35 PM Last Saved By: TIM.MCMILLEN

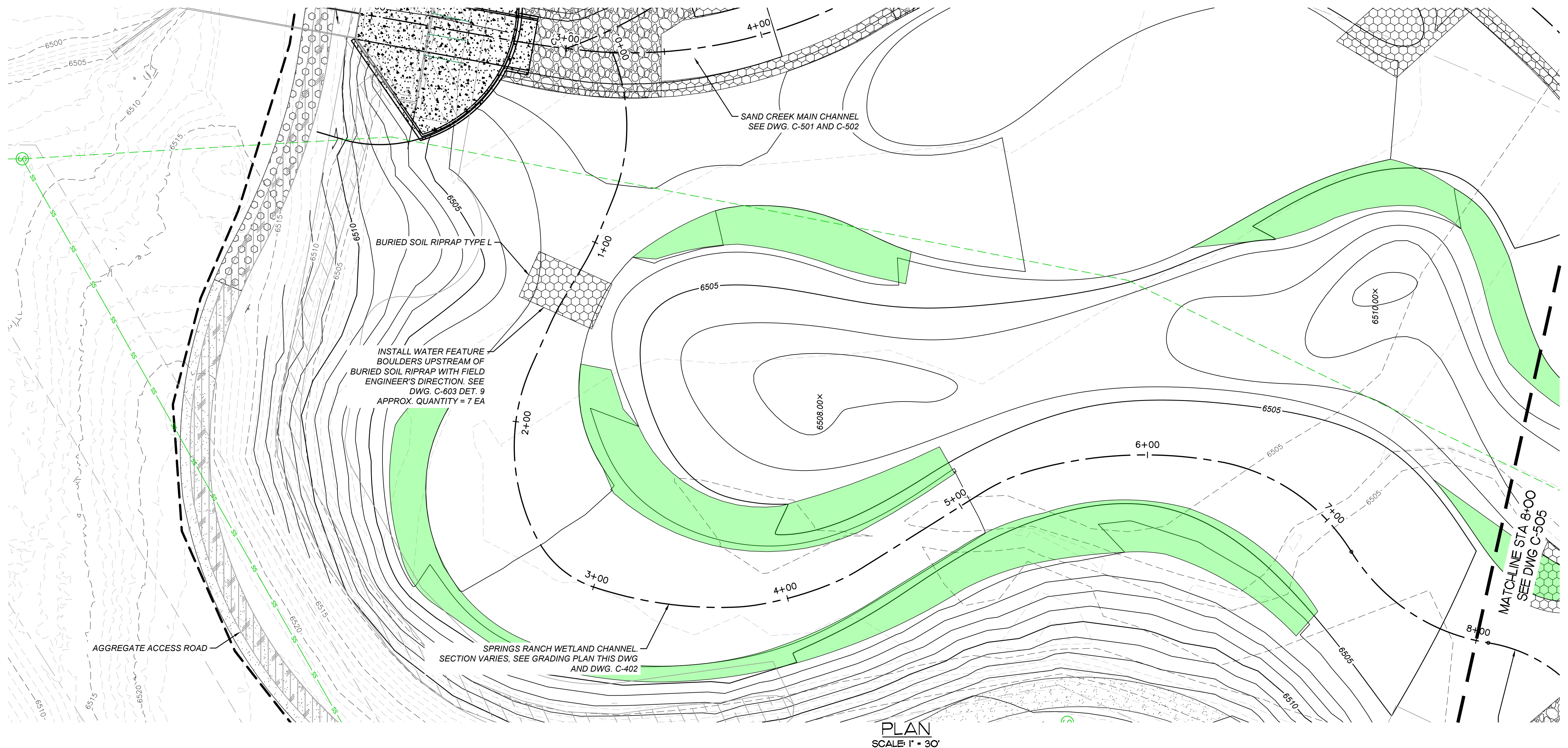

PLAN
SCALE: 1" = 30'

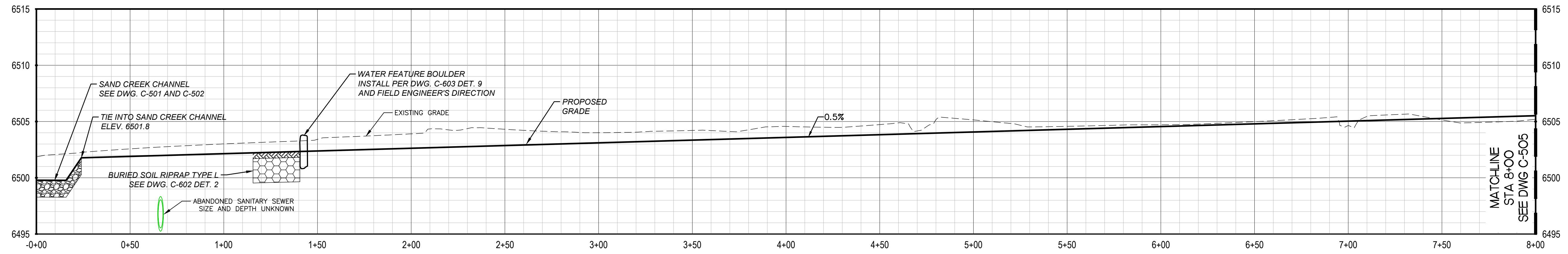

C PROFILE
C-504 HOR. SCALE: 1" = 30'
VER. SCALE: 1" = 5'

REV	REVISION DESCRIPTION	DATE	CHND	CHKD	APPR

CALL BEFORE YOU DIG

Know what's below.
Call before you dig.

CITY OF COLORADO SPRINGS
30 S. NEVADA AVE., SUITE 401
COLORADO SPRINGS, CO 80903
(719) 385-5980

Engineering | Architecture | Design-Build | Surveying | Planning | Geospatial Solutions
2480 W. 26TH AVE., UNIT B225 - DENVER COLORADO 80211
TEL. 303-751-0741, FAX 303-751-2581
www.merrick.com

PE STAMP

FOR AND ON BEHALF OF MERRICK & COMPANY

TITLE

SAND CREEK DETENTION POND NO. 2

SPRINGS RANCH WETLAND CHANNEL PLAN AND PROFILE

JOB NUMBER 65420975
DATE AUGUST 2024
DWG C-504
SHEET 16 of 51

THE CITY OF COLORADO SPRINGS IS PROVIDING THIS INFORMATION AS AN INSTRUMENT OF SERVICE. SERVICES BY MERRICK AND COMPANY FOR THIS PROJECT ARE NOT INTENDED OR REPRESENTED TO BE A FINISHED INSTRUMENT WITHOUT THE PRIOR WRITTEN CONSENT OF MERRICK AND COMPANY. SHALL BE AT THE SAME RISK FOR THE QUALITY OF THE INFORMATION PROVIDED TO MERRICK AND COMPANY.

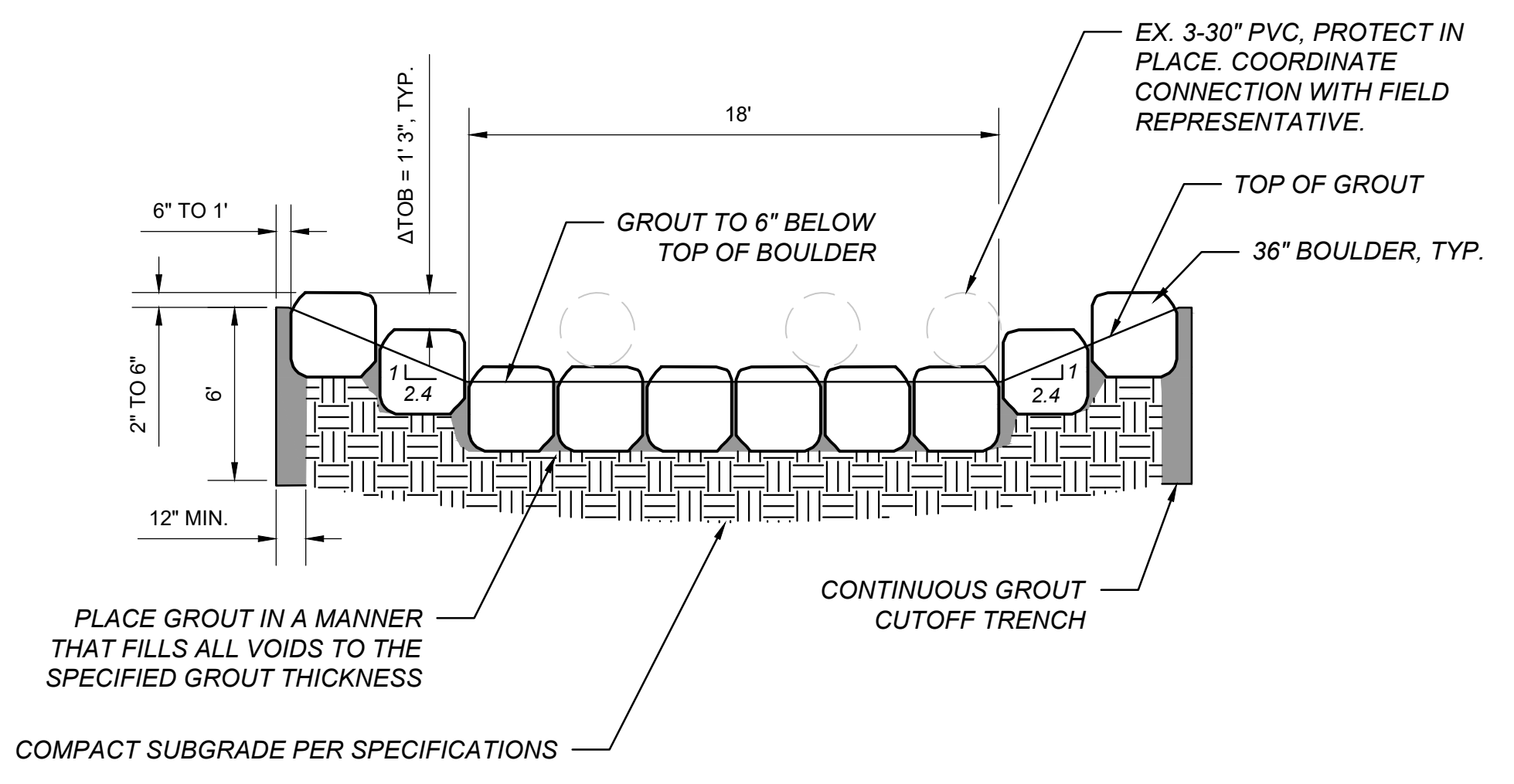
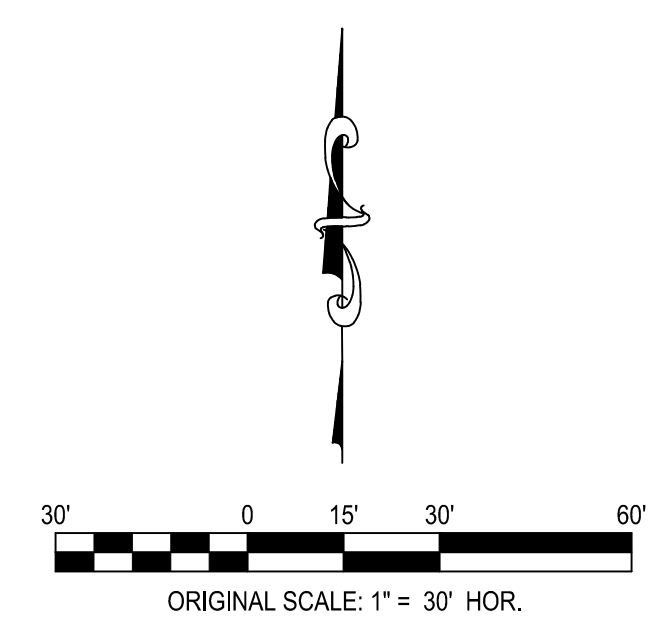
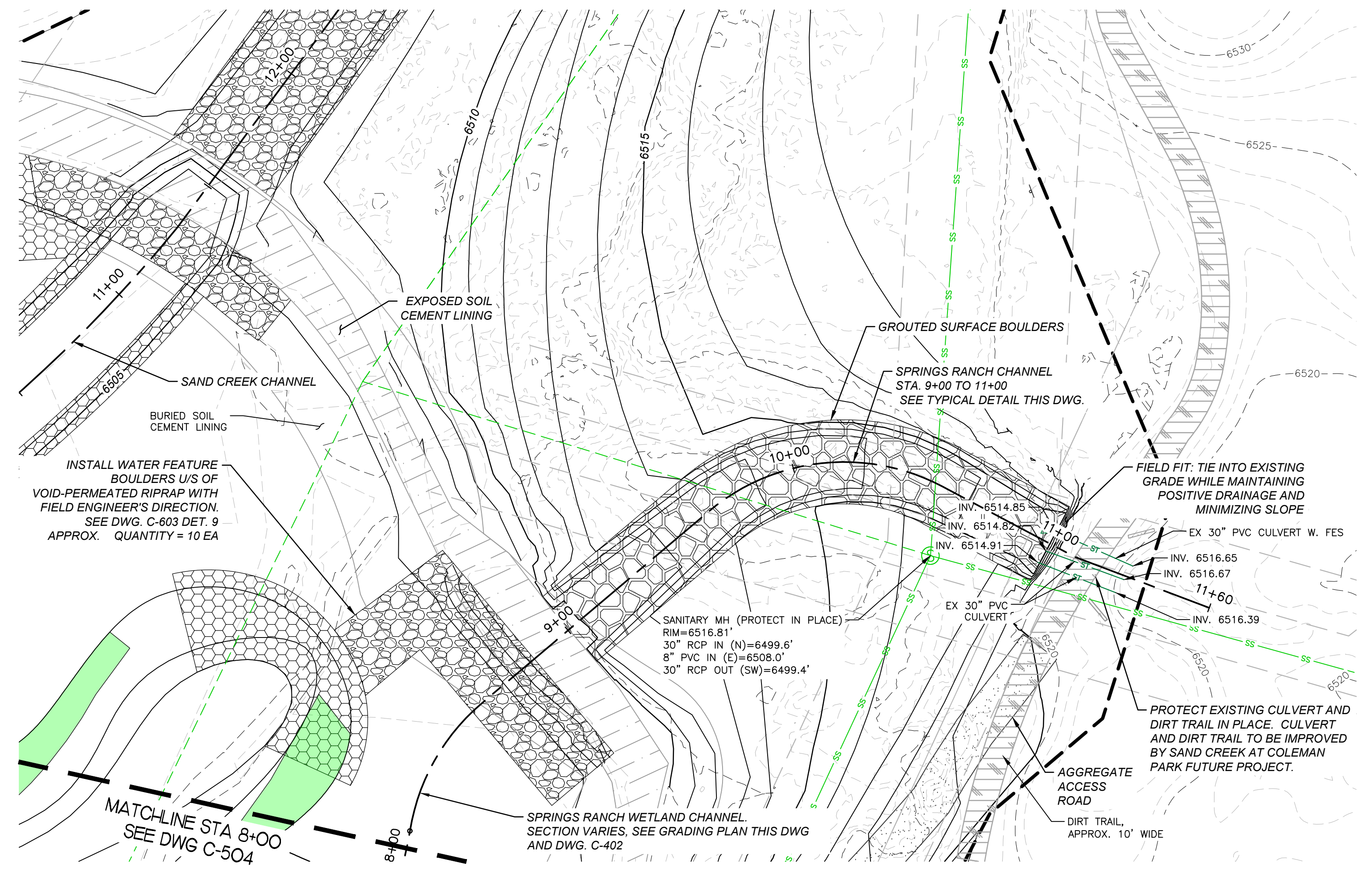

**SPRINGS RANCH CHANNEL
TYPICAL SECTION**
HOR. SCALE: 1" = 5'
VER. SCALE: 1" = 5'

NOTE: PLACE ONE ROW OF BOULDERS THAT TRANSITIONS BETWEEN THE TWO SECTIONS. FOR THE TRANSITION ROW, ΔTOB = 8", AND GROUT TO 4" BELOW TOP OF BOULDER.

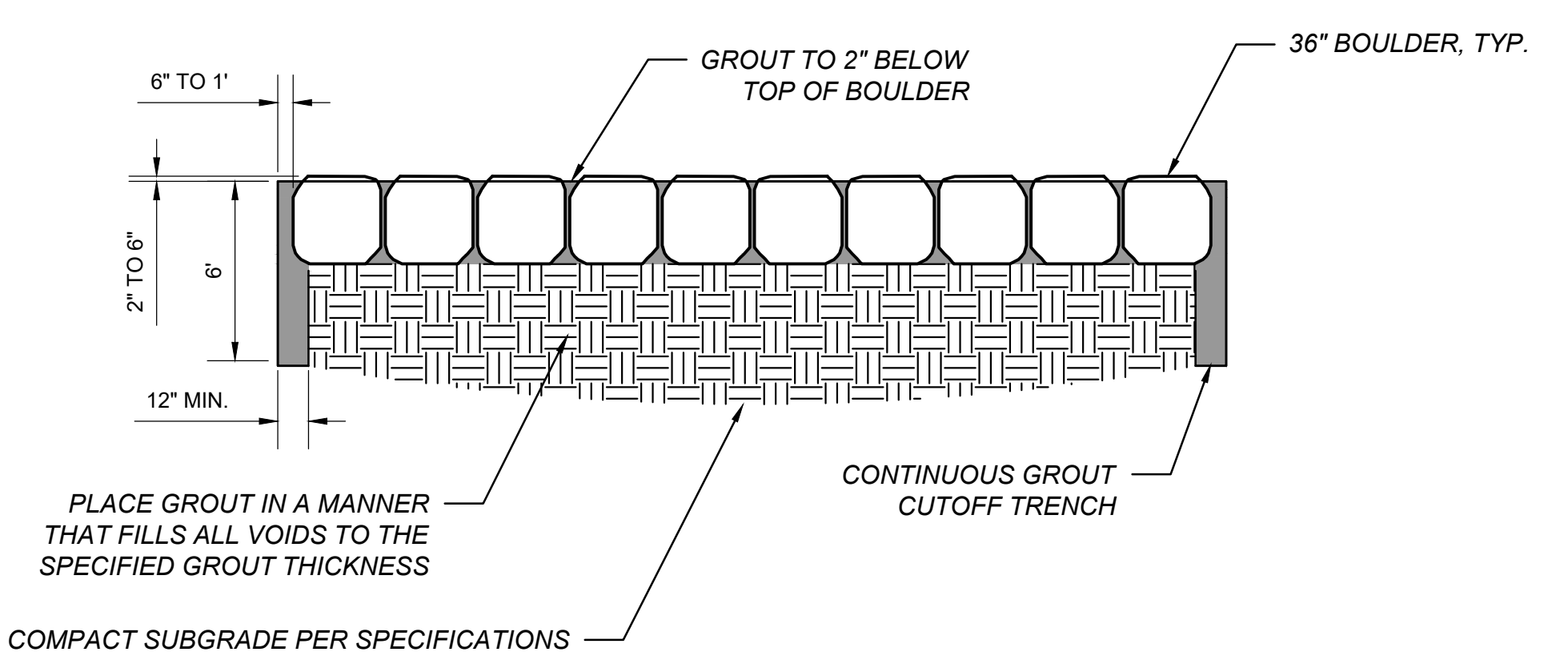

**SPRINGS RANCH CHANNEL
SECTION - DOWNSTREAM MOST ROW OF BOULDERS (STA. 9+00 +/-)**
HOR. SCALE: 1" = 5'
VER. SCALE: 1" = 5'

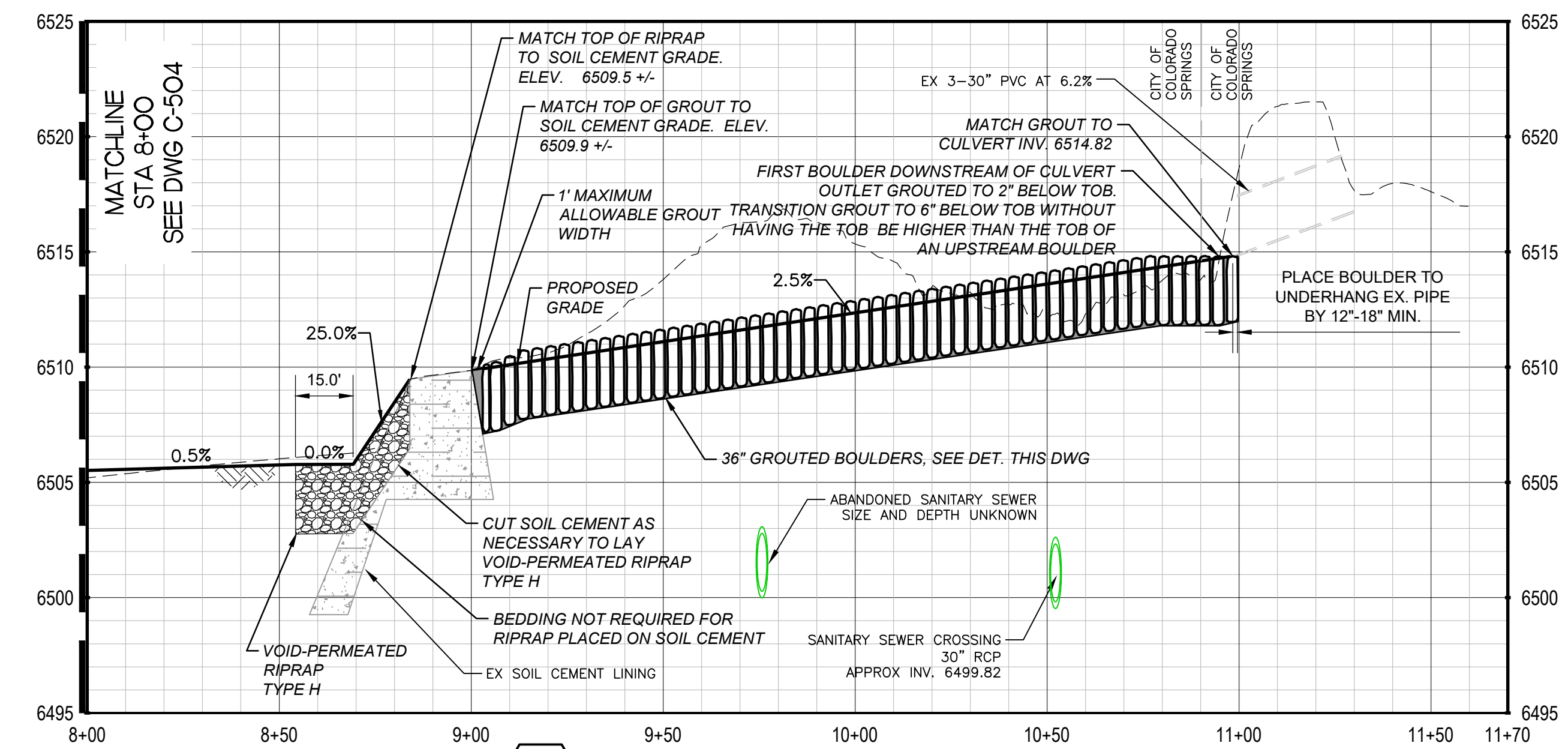

C PROFILE
HOR. SCALE: 1" = 30'
VER. SCALE: 1" = 5'

REV	REVISION DESCRIPTION	DATE	CHND	CHKD	APPR

CALL BEFORE YOU DIG

Know what's below.
Call before you dig.

CITY OF COLORADO SPRINGS
30 S. NEVADA AVE., SUITE 401
COLORADO SPRINGS, CO 80903
(719) 385-5980

MERRICK
Engineering | Architecture | Design-Build | Surveying | Planning | Geospatial Solutions
2480 W. 26TH AVE., UNIT B225 - DENVER COLORADO 80211
TEL. 303-751-0741, FAX 303-751-2581
www.merrick.com

PE STAMP

PROFESSIONAL ENGINEER
28989
9/04/2024

TITLE

SAND CREEK DETENTION POND NO. 2

SPRINGS RANCH CHANNEL PLAN AND PROFILE

JOB NUMBER: 65420975
DATE: AUGUST 2024
DWG: C-505
SHEET: 17 of 51

THE CITY OF COLORADO SPRINGS IS PROVIDING THIS INFORMATION AS AN INSTRUMENT OF SERVICE. SERVICES BY MERRICK AND COMPANY, INC. ARE THE PROPERTY OF MERRICK AND COMPANY, INC. AND ARE NOT TO BE REPRODUCED OR TRANSMITTED IN ANY FORM OR BY ANY MEANS, ELECTRONIC OR MECHANICAL, INCLUDING PHOTOCOPYING, RECORDING, OR BY ANY INFORMATION STORAGE AND RETRIEVAL SYSTEM, WITHOUT THE WRITTEN PERMISSION OF MERRICK AND COMPANY, INC. THIS INFORMATION IS PROVIDED AS AN INSTRUMENT OF SERVICE AND IS NOT TO BE USED FOR ANY OTHER PURPOSE. MERRICK AND COMPANY, INC. SHALL BE AT THE SOLE RISK FOR THE QUALITY OF ANY INFORMATION PROVIDED TO ANY USER OF THIS INFORMATION.

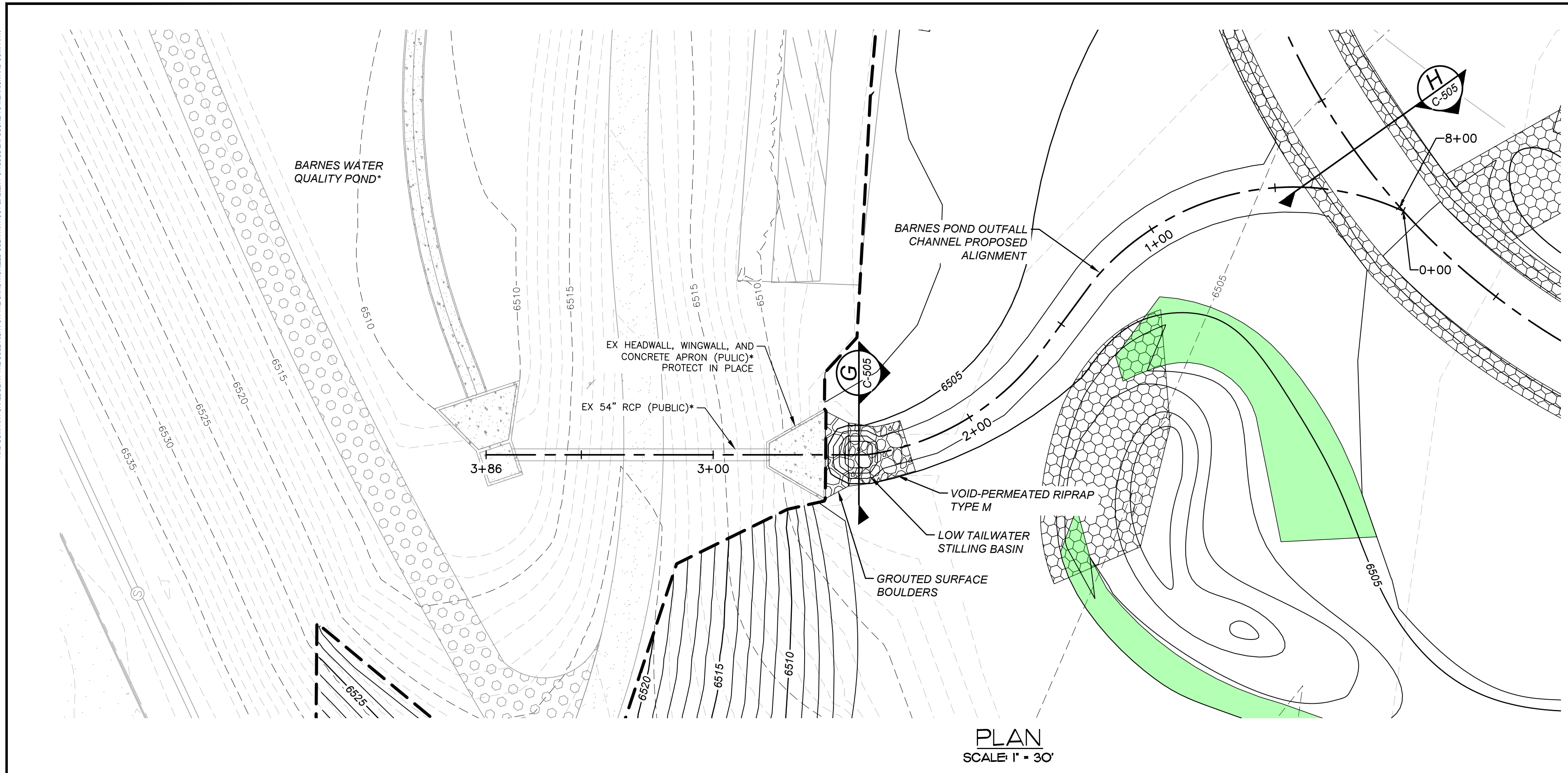

PLAN
SCALE 1" = 30'

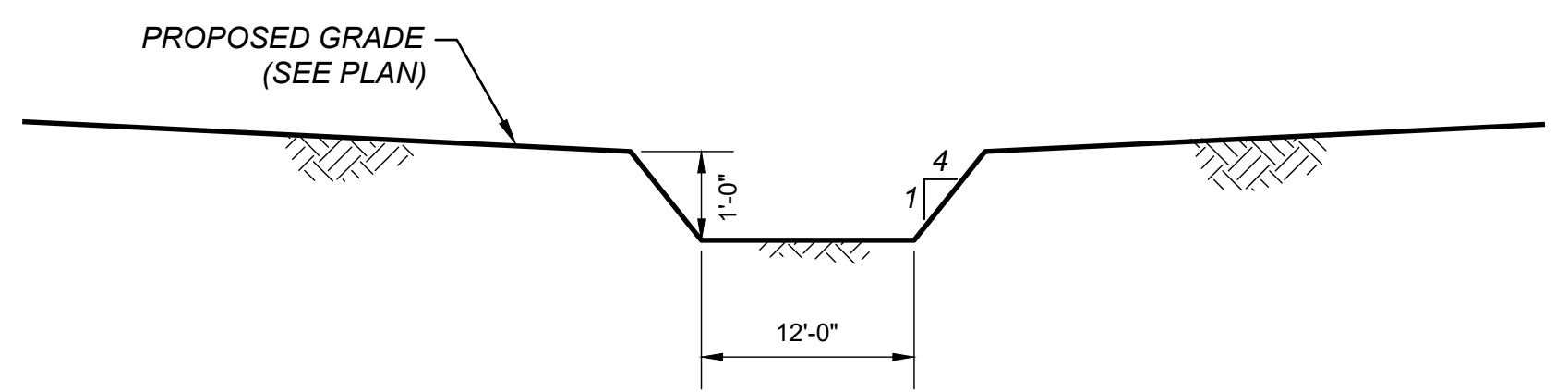

BARNES POND OUTFALL CHANNEL
TYPICAL SECTION
HOR. SCALE: 1" = 10'
VER. SCALE: 1" = 2'

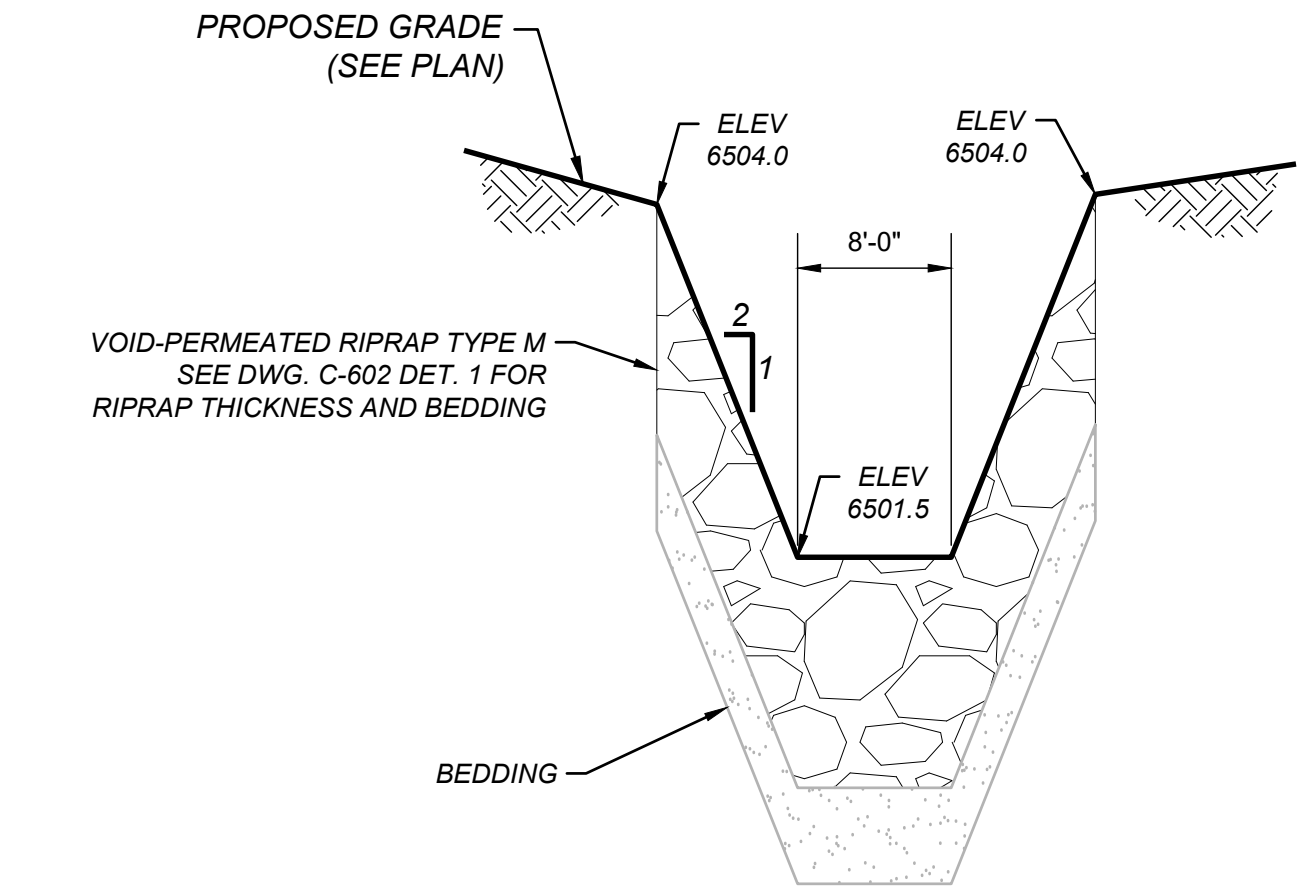

SECTION G
HOR. SCALE: 1" = 10'
VER. SCALE: 1" = 2'

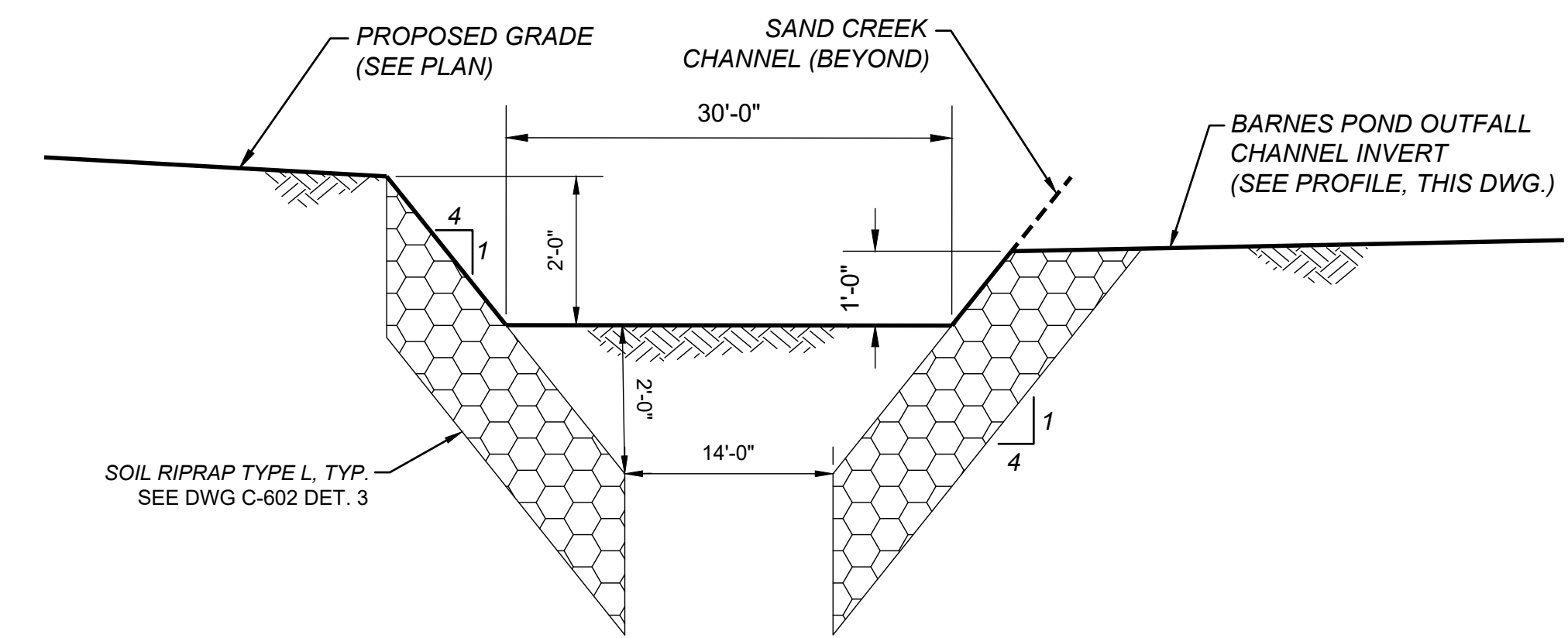

SECTION H
HOR. SCALE: 1" = 10'
VER. SCALE: 1" = 2'

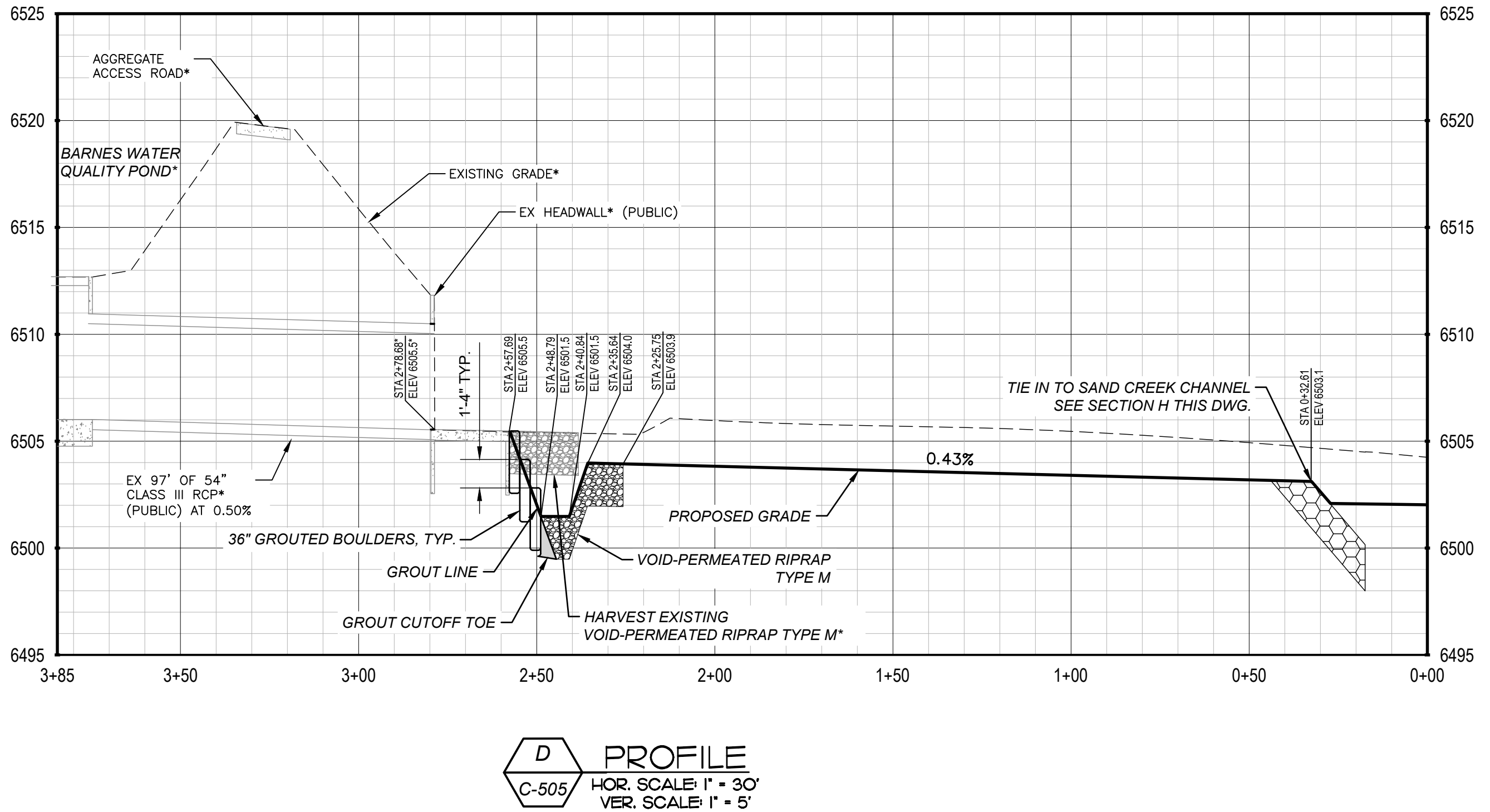

D PROFILE
C-505
HOR. SCALE: 1" = 30'
VER. SCALE: 1" = 5'

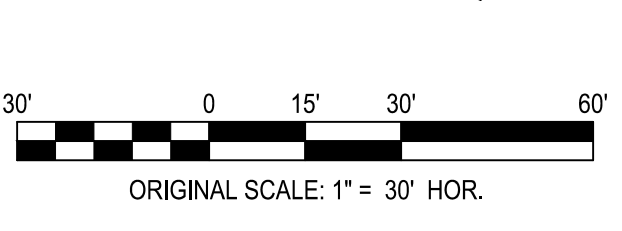

*THIS INFRASTRUCTURE ELEMENT IS PROPOSED AS PART OF THE BARNES WATER QUALITY POND PROJECT, WHICH IS TO BE COMPLETED BEFORE CONSTRUCTION OF SAND CREEK POND NO. 2 RESTORATION BEGINS.

File Location: D:\Denver_North\Projects\City of Colorado Springs\Sand Creek Pond No. 2\CAD\CDS\0975-Barnes_Outlet_Pipe_P&P.dwg Pld Date: 8/26/2024 4:37 PM Last Saved By: TIM/MCMULLEN

REV	REVISION DESCRIPTION	DATE	CHND	CHKD	APPR

CALL BEFORE YOU DIG

Know what's below.
Call before you dig.

CITY OF COLORADO SPRINGS
30 S. NEVADA AVE., SUITE 401
COLORADO SPRINGS, CO 80903
(719) 385-5980

2480 W. 26TH AVE., UNIT B225 - DENVER COLORADO 80211
TEL. 303-751-0741, FAX 303-751-2581
www.merrick.com

PE STAMP

FOR AND ON BEHALF OF MERRICK & COMPANY

TITLE

SAND CREEK DETENTION POND NO. 2

BARNES WQ POND OUTFALL PIPE AND CHANNEL PLAN AND PROFILE

JOB NUMBER: 65420975

DATE: AUGUST 2024

DWG: C-506

SHEET 18 of 51

THE NEW ORANGE COUNTY ENGINEERING DIVISION HAS REVIEWED THIS INSTRUMENT OF SERVICE PREPARED BY MERRICK AND COMPANY FOR A RESURFACING PROJECT. REUSE OR MODIFICATION OF ANY INFORMATION NOT A PART OF THIS INSTRUMENT OF SERVICE IS PROHIBITED. WITHOUT THE PRIOR WRITTEN CONSENT OF MERRICK AND COMPANY, THIS INFORMATION SHALL BE KEPT IN CONFIDENCE AND NOT BE REPRODUCED OR TRANSMITTED IN ANY FORM OR BY ANY MEANS, ELECTRONIC OR MECHANICAL, INCLUDING PHOTOCOPYING, RECORDING, OR BY ANY INFORMATION STORAGE AND RETRIEVAL SYSTEM.

File Location: D:\Denver_North\Projects\City of Colorado Springs\Sand Creek Pond No. 2\CAD\CDS\0975-ROAD-PROFILES.dwg Plot Date: 8/26/2024 4:38 PM Last Saved By: TIMMCMULLEN

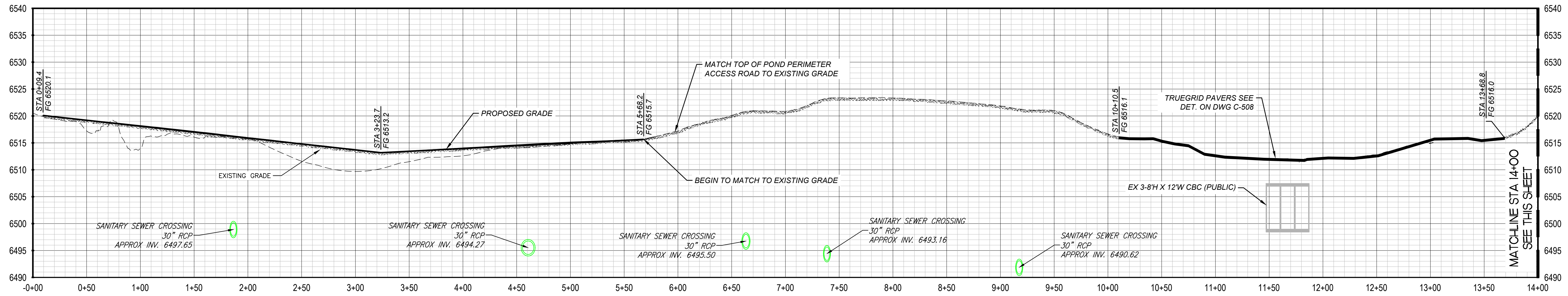

E POND PERIMETER ACCESS ROAD PROFILE
 C-506
 HOR. SCALE: 1" = 50'
 VER. SCALE: 1" = 10'

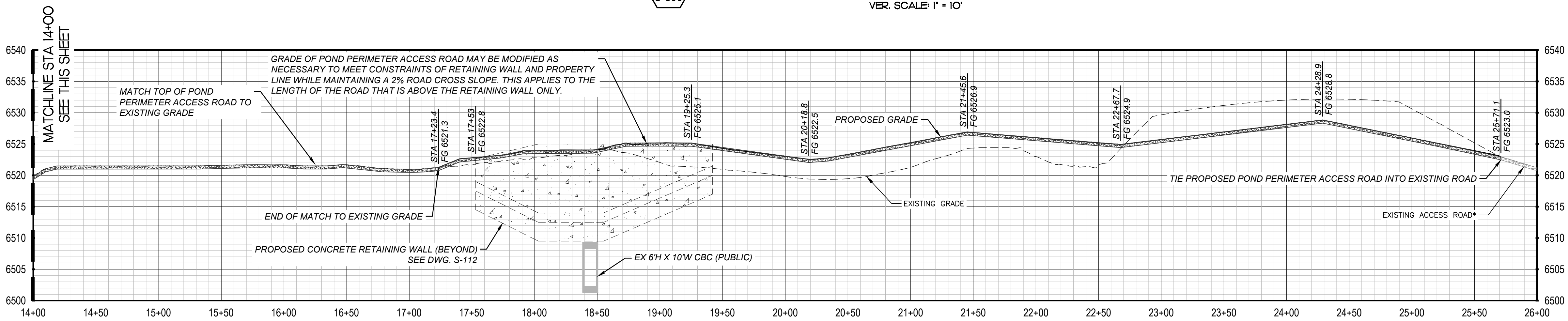

E POND PERIMETER ACCESS ROAD PROFILE
 C-506
 HOR. SCALE: 1" = 50'
 VER. SCALE: 1" = 10'

*THIS INFRASTRUCTURE ELEMENT IS PROPOSED AS PART OF THE BARNES WATER QUALITY POND PROJECT, WHICH IS TO BE COMPLETED BEFORE CONSTRUCTION OF SAND CREEK POND NO. 2 RESTORATION BEGINS.

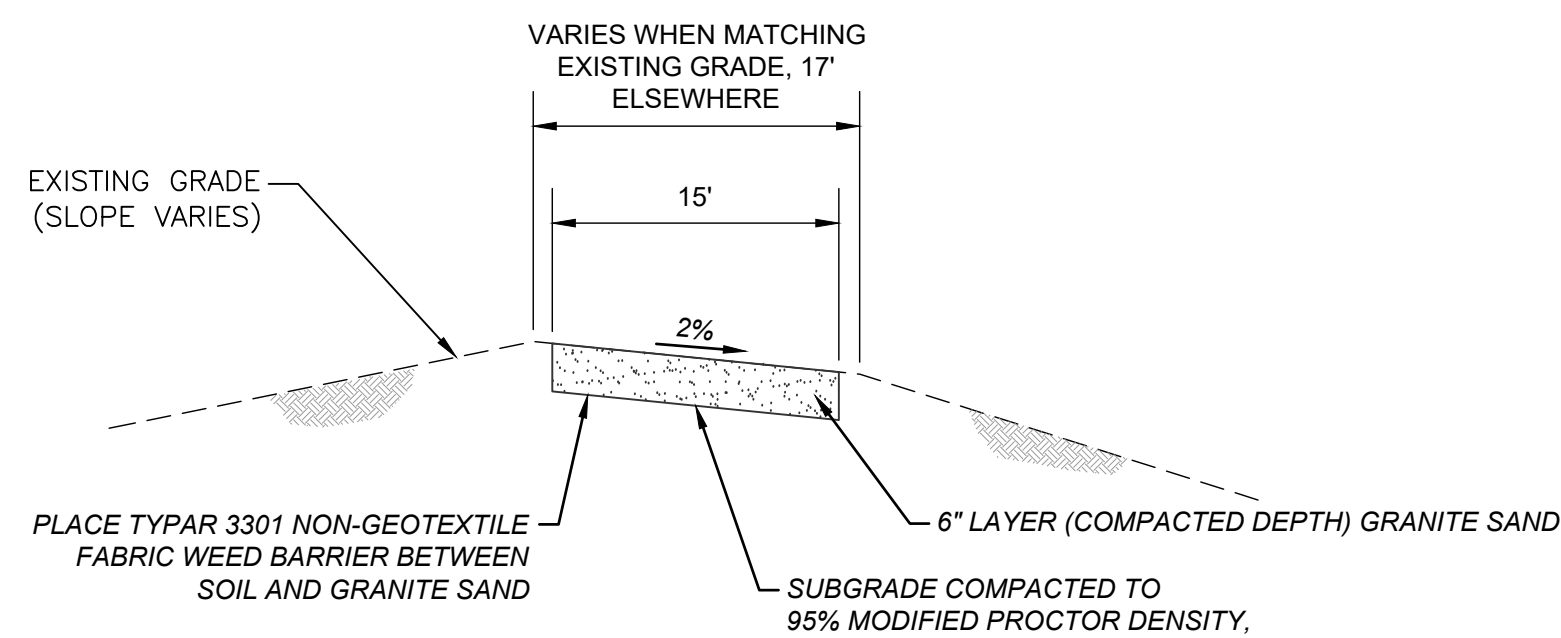

POND PERIMETER ACCESS ROAD SECTION

NTS

REV	REVISION DESCRIPTION	DATE	CHND	CHKD	APPR



CITY OF COLORADO SPRINGS
 30 S. NEVADA AVE., SUITE 401
 COLORADO SPRINGS, CO 80903
 (719) 385-5980



TITLE: SAND CREEK DETENTION POND NO. 2
 POND PERIMETER ACCESS ROAD PROFILE

JOB NUMBER: 65420975
 DATE: AUGUST 2024
 DWG: C-507
 SHEET: 19 of 51

THE USE OF THIS DRAWING IS LIMITED TO THE PROJECT AND SITE SPECIFICALLY IDENTIFIED HEREIN. ANY OTHER USE, REUSE OR MODIFICATION OF ANY INFORMATION NOT A FINISHED INSTRUMENT WITHOUT THE PRIOR EXPRESS WRITTEN CONSENT OF MERRICK AND COMPANY SHALL BE AT THE USER'S RISK. THE USER SHALL BE RESPONSIBLE FOR OBTAINING ALL NECESSARY PERMITS AND APPROVALS.

File Location: D:\Denver_North\Projects\City of Colorado Springs\Sand Creek Pond No. 2\CAD\09\0975-ROAD-PROFILES.dwg Plot Date: 8/26/2024 4:38 PM Last Saved By: TIMMCMULLEN

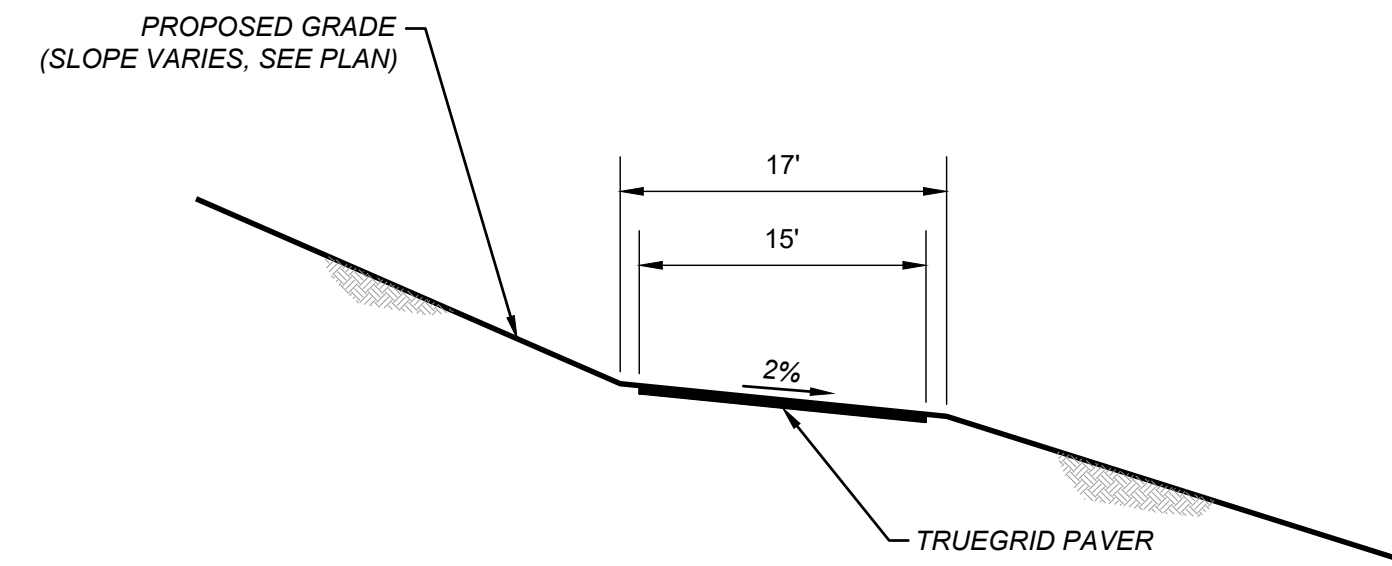
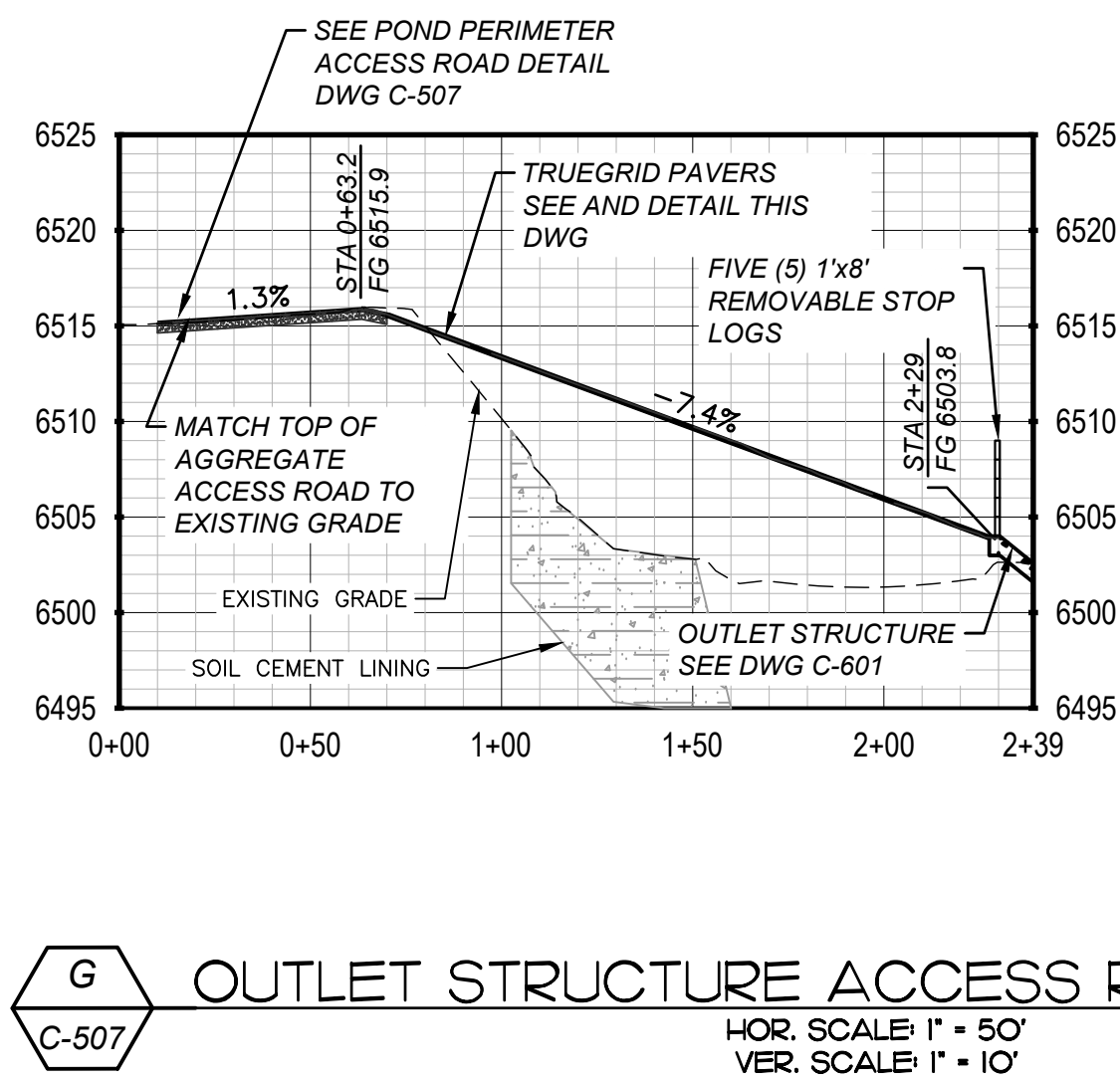
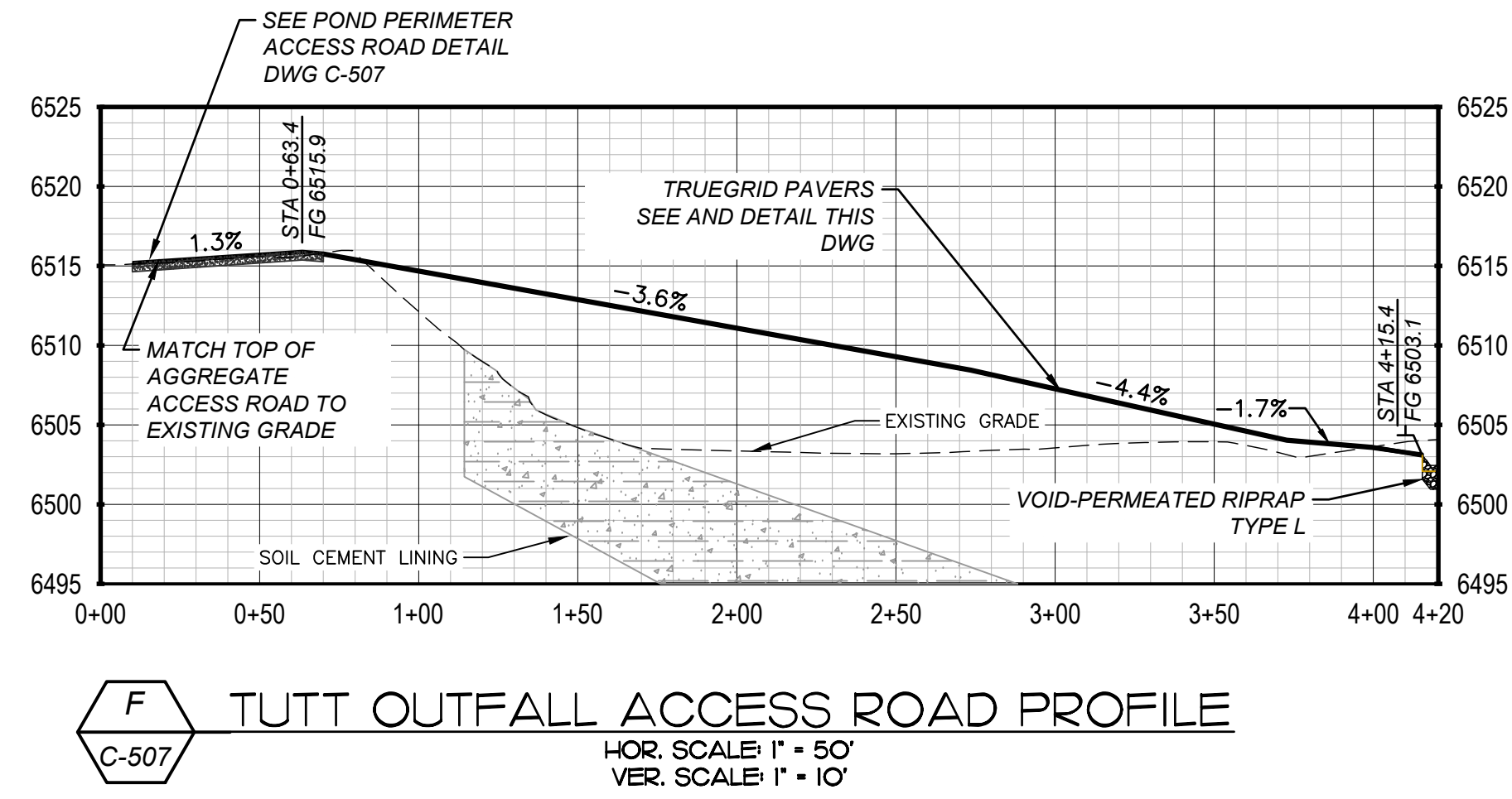

TRUEGRID PAVERS ACCESS ROAD
 NTS

REV	REVISION DESCRIPTION	DATE	CHND	CHKD	APPR

CALL BEFORE YOU DIG

Know what's below.
 Call before you dig.

CITY OF COLORADO SPRINGS
 30 S. NEVADA AVE., SUITE 401
 COLORADO SPRINGS, CO 80903
 (719) 385-5980

Engineering | Architecture | Design-Build | Surveying | Planning | Geospatial Solutions
 2480 W. 26TH AVE., UNIT B225 - DENVER COLORADO 80211
 TEL. 303-751-0741, FAX 303-751-2581
 www.merrick.com

PE STAMP

FOR AND ON BEHALF OF MERRICK & COMPANY

TITLE

SAND CREEK DETENTION POND NO. 2

OUTLET STRUCTURE AND TUTT OUTFALL ACCESS ROAD PROFILES AND DETAILS

JOB NUMBER: 65420975
 DATE: AUGUST 2024
 DWG: **C-508**
 SHEET: 20 of 51

THE USER SHALL BE RESPONSIBLE FOR OBTAINING ALL NECESSARY PERMITS AND APPROVALS FROM ALL APPLICABLE AGENCIES AND AGENCIES. THE USER SHALL BE RESPONSIBLE FOR OBTAINING ALL NECESSARY PERMITS AND APPROVALS FROM ALL APPLICABLE AGENCIES AND AGENCIES. THE USER SHALL BE RESPONSIBLE FOR OBTAINING ALL NECESSARY PERMITS AND APPROVALS FROM ALL APPLICABLE AGENCIES AND AGENCIES.

File Location: D:\Denver_North\Projects\City of Colorado Springs\Sand Creek Pond No. 2\CAD\CDS\0975-DETAIL-POND-OUTFALL.dwg Plot Date: 8/26/2024 4:38 PM Last Saved By: TIM MCMULLEN

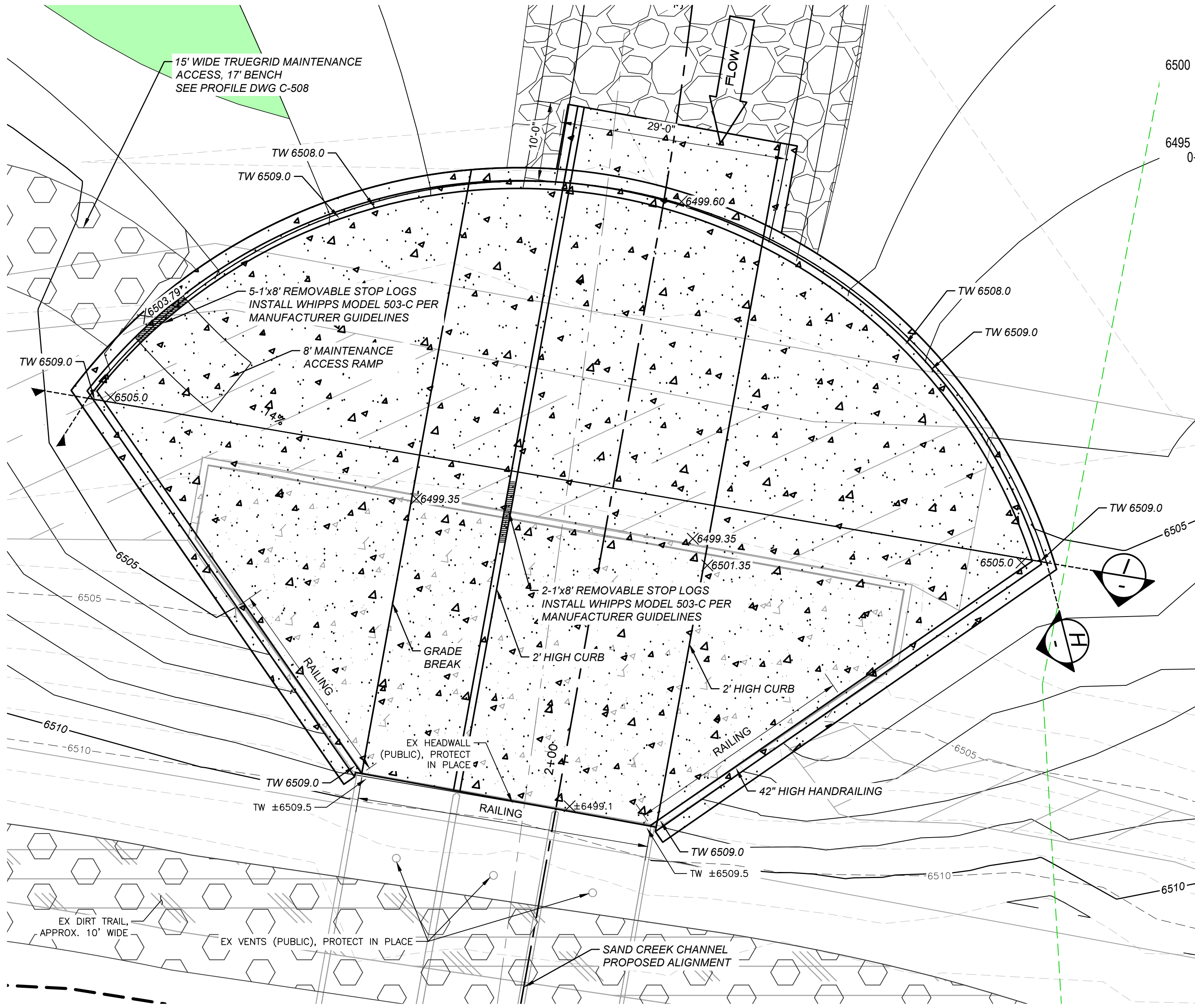
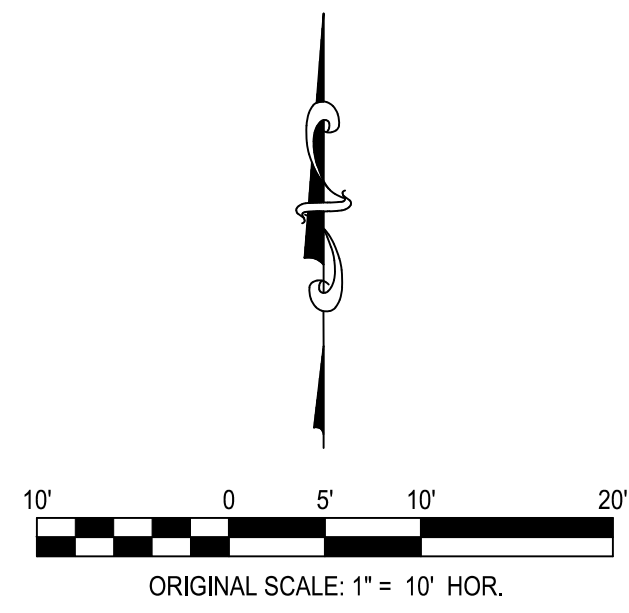

PLAN
SCALE: 1" = 10'

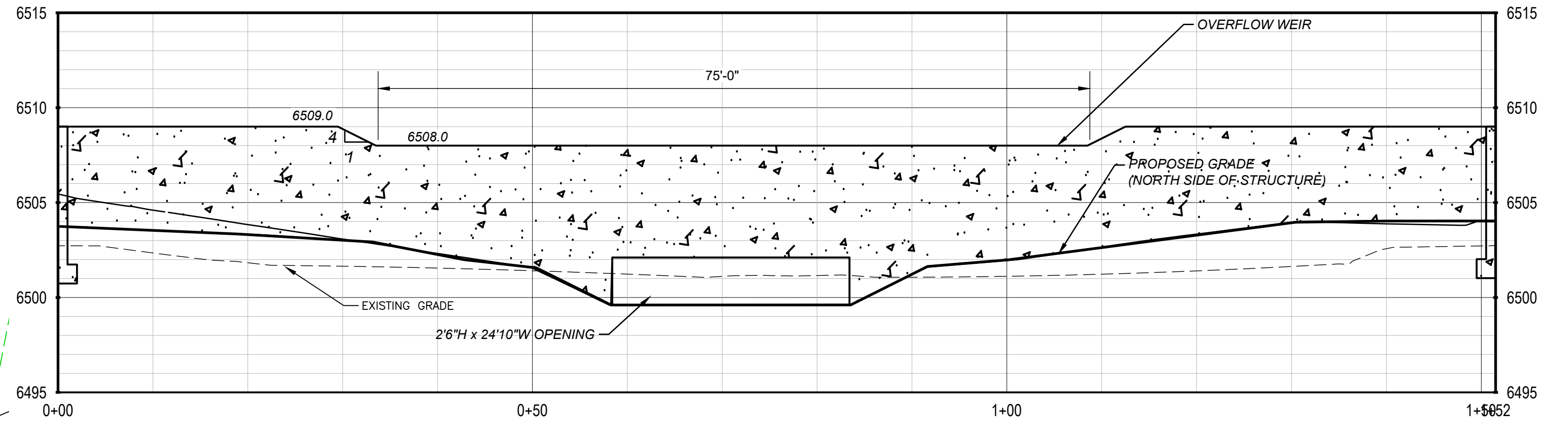

SECTION H
HOR. SCALE: 1" = 10'
VER. SCALE: 1" = 5'

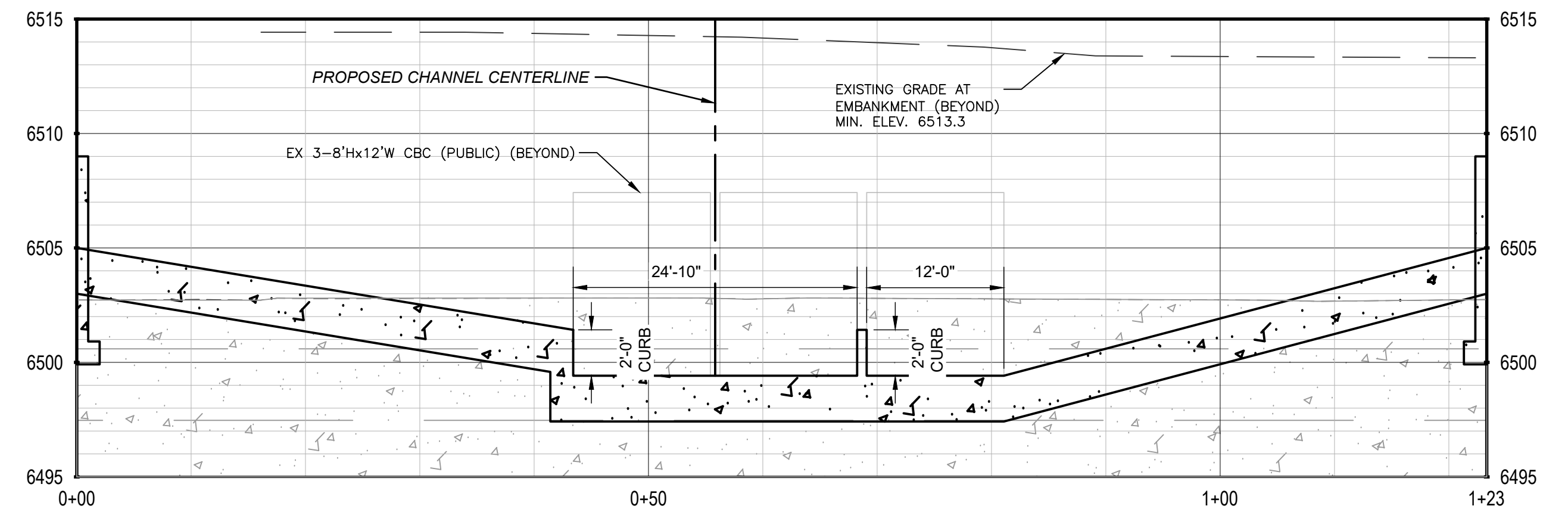

SECTION I
HOR. SCALE: 1" = 10'
VER. SCALE: 1" = 5'

SEE DWGS S-100 THROUGH S-117 FOR STRUCTURAL DESIGN.
DWGS S-100 THROUGH S-117 TO TAKE PRECEDENCE OVER DWG C-601 IF CONFLICTING.

REV	REVISION DESCRIPTION	DATE	CHND	CHKD	APPR

CALL BEFORE YOU DIG



Know what's below.
Call before you dig.

CITY OF COLORADO SPRINGS
30 S. NEVADA AVE., SUITE 401
COLORADO SPRINGS, CO 80903
(719) 385-5980



Engineering | Architecture | Design-Build | Surveying | Planning | Geospatial Solutions
2480 W. 26TH AVE., UNIT B225 - DENVER COLORADO 80211
TEL. 303-751-0741, FAX 303-751-2581
www.merrick.com

PE STAMP



FOR AND ON BEHALF OF MERRICK & COMPANY

TITLE

SAND CREEK DETENTION POND NO. 2

POND OUTLET STRUCTURE
DETAIL

JOB NUMBER 65420975
DATE AUGUST 2024
DWG C-601
SHEET 21 of 51

THE USE OF ANY OTHER ENGINEERING MATERIAL OR INSTRUMENTATION IS AN INSTRUMENT OF SERVICE PROVIDED BY MERRICK AND COMPANY, INC. IN CONNECTION WITH THIS PROJECT. IT IS NOT INTENDED OR REPRESENTED TO BE SUITABLE FOR REUSE IN WHOLE OR IN PART OR FOR EXTENSION OF THE PROJECT OR ON ANY OTHER PROJECT. REUSE OR MODIFICATION OF ANY INSTRUMENTATION WITHOUT THE WRITTEN PERMISSION OF MERRICK AND COMPANY SHALL BE AT THE USER'S RISK. THE USER SHALL BE RESPONSIBLE FOR OBTAINING ALL NECESSARY PERMITS AND APPROVALS.

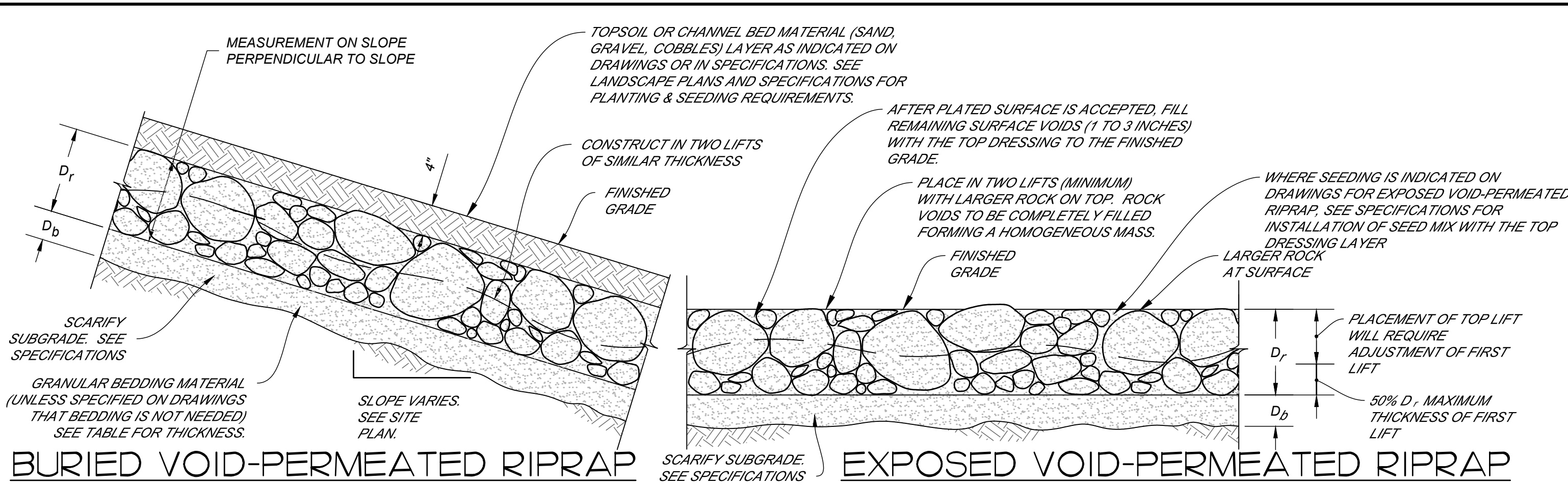

BURIED VOID-PERMEATED RIPRAP

EXPOSED VOID-PERMEATED RIPRAP

USED THIS PROJECT	RIPRAP TYPE	D ₅₀	D _r	D _b / SCARIFY DEPTH
	VL	6	12	8
X	L	9	18	8
X	M	12	24	10
X	H	18	36	12
	VH	24	48	12

- NOTES FOR VOID-PERMEATED RIPRAP:**
- EXPOSED AND BURIED VOID-PERMEATED RIPRAP DETAILS ARE APPLICABLE TO FLAT OR SLOPED AREAS. REFER TO SITE PLAN FOR ACTUAL LOCATION AND LIMITS OF EACH TYPE.
 - REFER TO SPECIFICATIONS FOR MATERIALS, MIXING, AND PLACEMENT REQUIREMENTS FOR VOID-PERMEATED RIPRAP.
 - GENERAL PLACEMENT TECHNIQUES SHOULD RESULT IN LARGER ROCK AT THE SURFACE WITH ROCK SECURELY INTERLOCKED AT THE DESIGN THICKNESS AND GRADE. COMPACTION AND LEVELING SHOULD RESULT IN MINIMAL VOIDS AND PROJECTIONS ABOVE GRADE. TYPICAL FOR BOTH BURIED AND EXPOSED VOID-PERMEATED RIPRAP.
 - FINAL VOID-PERMEATED RIPRAP TO BE COMPACTED BY FULL LOADING OF EXCAVATOR BUCKET OR VIBRATORY PLATE COMPACTOR ATTACHED TO EXCAVATOR BOOM/STICK AS APPROVED BY ENGINEER. ANY SOFT, YIELDING OR POCKETS OF SMALL ROCK WILL BE REWORKED.
 - SUBGRADE SHALL BE SCARIFIED PRIOR TO PLACEMENT OF RIPRAP. SEE SPECIFICATIONS.
 - COORDINATE ROCK PLACEMENT TO PROVIDE TREE OR SHRUB PLANTING PITS WHEN INDICATED ON PLANTING PLANS.

D_r = DEPTH OF RIPRAP LAYER. (UNLESS NOTED OTHERWISE ON PLANS, DETAILS, AND SECTIONS)

D_b = MINIMUM BEDDING THICKNESS. SEE SPECIFICATIONS

TYPICAL VOID-PERMEATED RIPRAP PLACEMENT

NTS

1
C-602

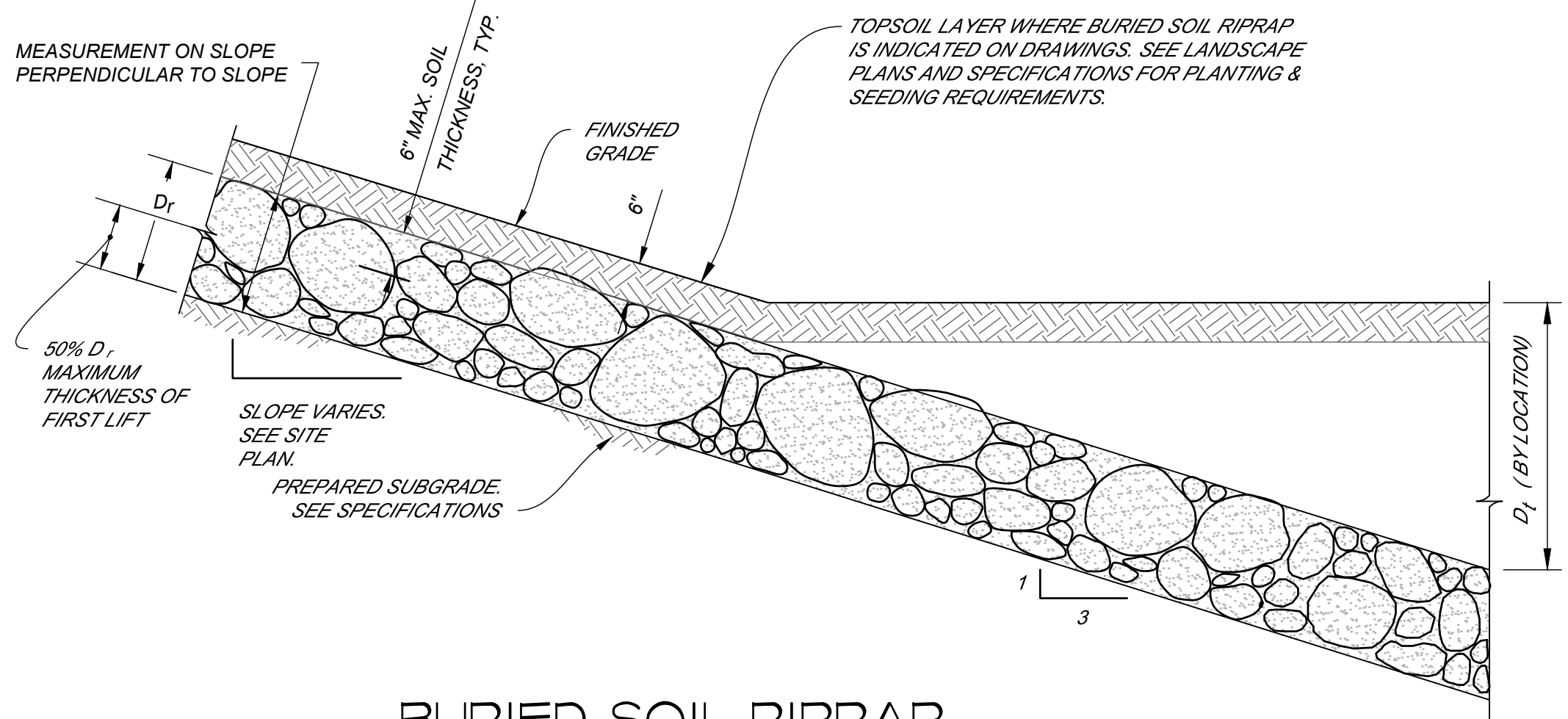

BURIED SOIL RIPRAP

LOCATION	D _t
ISLAND OR D/S OF WATER FEATURE BOULDERS	24
BARNES WATER QUALITY POND EMERGENCY SPILLWAY	36

ALL DIMENSIONS IN INCHES

USED THIS PROJECT	RIPRAP TYPE	D ₅₀	D _r
	VL	6	20
X	L	9	26
	M	12	32
	H	18	44

D_r = DEPTH OF RIPRAP LAYER. (UNLESS NOTED OTHERWISE ON PLANS, DETAILS, AND SECTIONS)

- NOTES FOR SOIL RIPRAP:**
- EXPOSED AND BURIED SOIL RIPRAP DETAILS ARE APPLICABLE TO FLAT OR SLOPED AREAS. REFER TO SITE PLAN FOR ACTUAL LOCATION AND LIMITS OF EACH TYPE.
 - REFER TO SPECIFICATIONS FOR MATERIALS, MIXING, AND PLACEMENT REQUIREMENTS FOR SOIL RIPRAP.
 - GENERAL PLACEMENT TECHNIQUES SHOULD RESULT IN LARGER ROCK AT THE SURFACE WITH ROCK SECURELY INTERLOCKED AT THE DESIGN THICKNESS AND GRADE. COMPACTION AND LEVELING SHOULD RESULT IN MINIMAL VOIDS AND PROJECTIONS ABOVE GRADE. TYPICAL FOR BOTH BURIED AND EXPOSED SOIL RIPRAP.
 - FINAL SOIL RIPRAP TO BE COMPACTED BY FULL LOADING OF EXCAVATOR BUCKET OR VIBRATORY PLATE COMPACTOR ATTACHED TO EXCAVATOR BOOM/STICK AS APPROVED BY ENGINEER. ANY SOFT, YIELDING OR POCKETS OF SMALL ROCK WILL BE REWORKED.
 - COORDINATE ROCK PLACEMENT TO PROVIDE TREE OR SHRUB PLANTING WELLS WHEN INDICATED ON PLANTING PLANS.

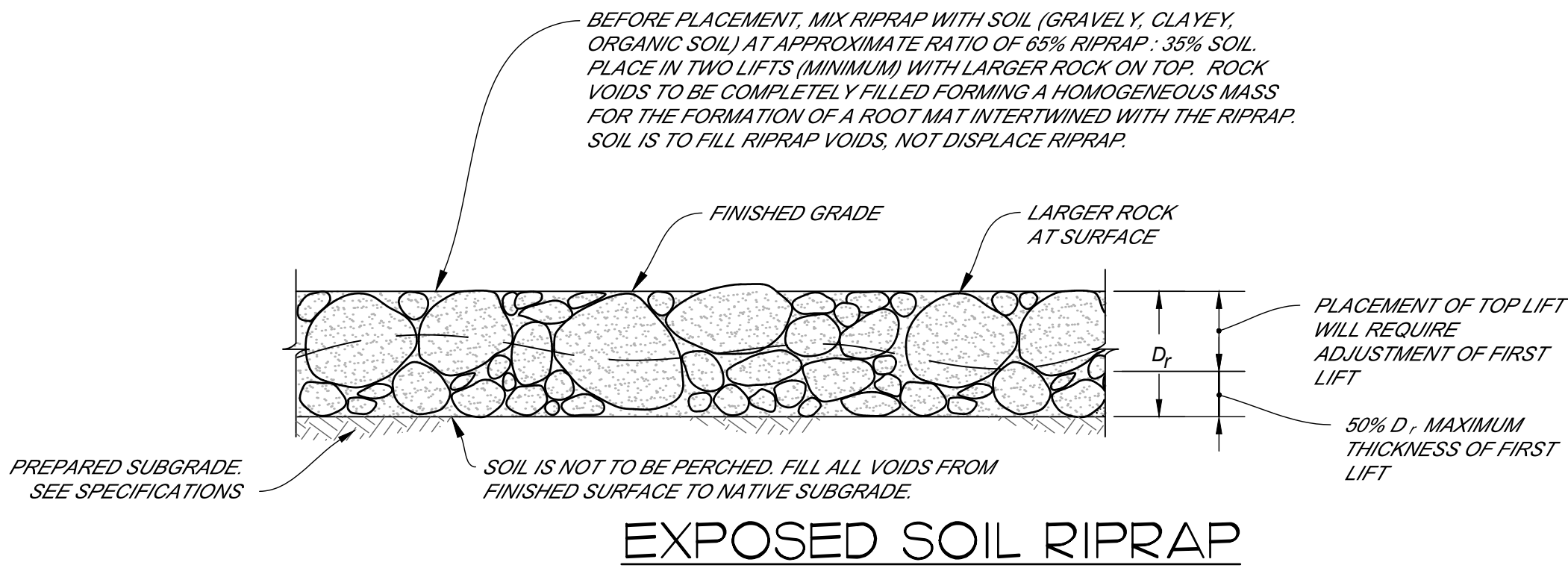

EXPOSED SOIL RIPRAP

TYPICAL SOIL RIPRAP PLACEMENT

NTS

2
C-602

File Location: Q:\Denver - North Projects\City of Colorado Springs\Sand Creek Pond No. 2\CAD\CDS\0975-DETAIL-RIPRAP.dwg Plot Date: 8/26/2024 4:39 PM Last Saved By: TIM.MCMILLEN

REV	REVISION DESCRIPTION	DATE	CHND	CHKD	APPR

CALL BEFORE YOU DIG

Know what's below.
Call before you dig.

CITY OF COLORADO SPRINGS
 30 S. NEVADA AVE., SUITE 401
 COLORADO SPRINGS, CO 80903
 (719) 385-5980

Engineering | Architecture | Design-Build | Surveying | Planning | Geospatial Solutions

2480 W. 26TH AVE., UNIT B225 - DENVER COLORADO 80211
 TEL. 303-751-0741, FAX 303-751-2581
 www.merrick.com

PE STAMP

FOR AND ON BEHALF OF MERRICK & COMPANY

TITLE

SAND CREEK DETENTION POND NO. 2

RIPRAP DETAILS

JOB NUMBER	65420975
DATE	AUGUST 2024
DWG	C-602
SHEET	22 of 51

THE NEW ORANGE COUNTY ENGINEERING DIVISION HAS REVIEWED THIS INSTRUMENT OF SERVICES AGREEMENT AND APPROVED FOR THE PROJECT. REUSE OR MODIFICATION OF ANY INFORMATION NOT A FINISHED INSTRUMENT WITHOUT THE PRIOR EXPRESS WRITTEN CONSENT OF MERRICK AND COMPANY SHALL BE AT THE USER'S RISK FOR THE USER'S USE WITHOUT LIABILITY TO MERRICK AND COMPANY.

File Location: D:\Denver_North\Projects\City of Colorado Springs\Sand Creek Pond No. 2\CAD\CCS\0975-SITE_PLAN.dwg Plt Date: 8/26/2024 4:40 PM Last Saved By: TIM.MCMULLEN

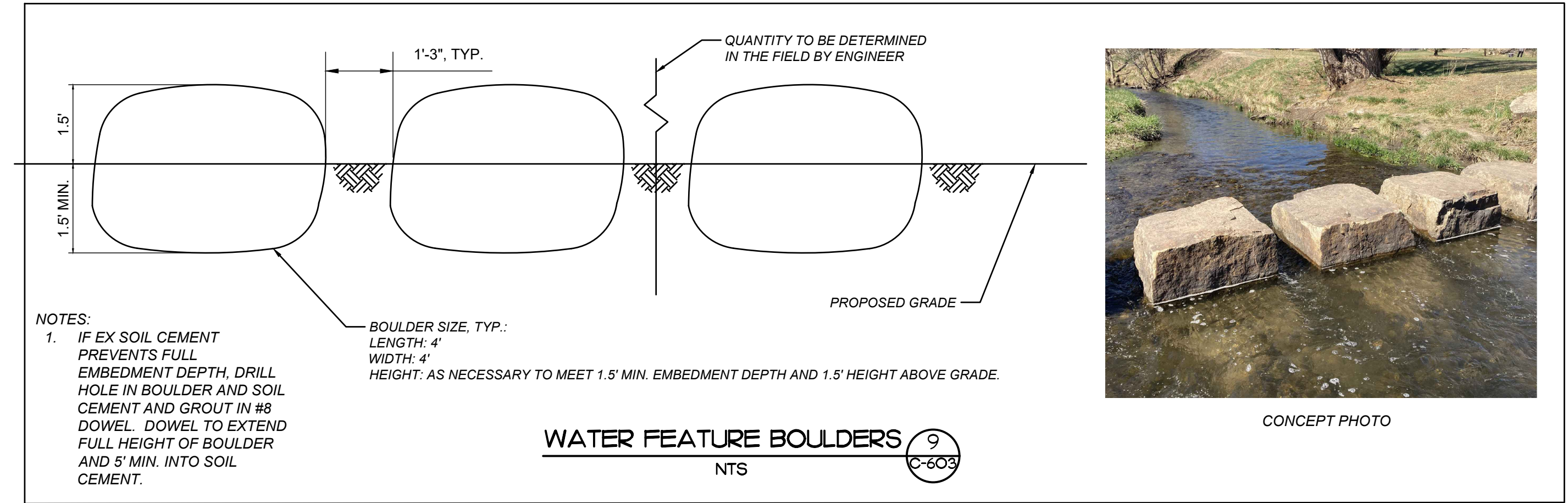
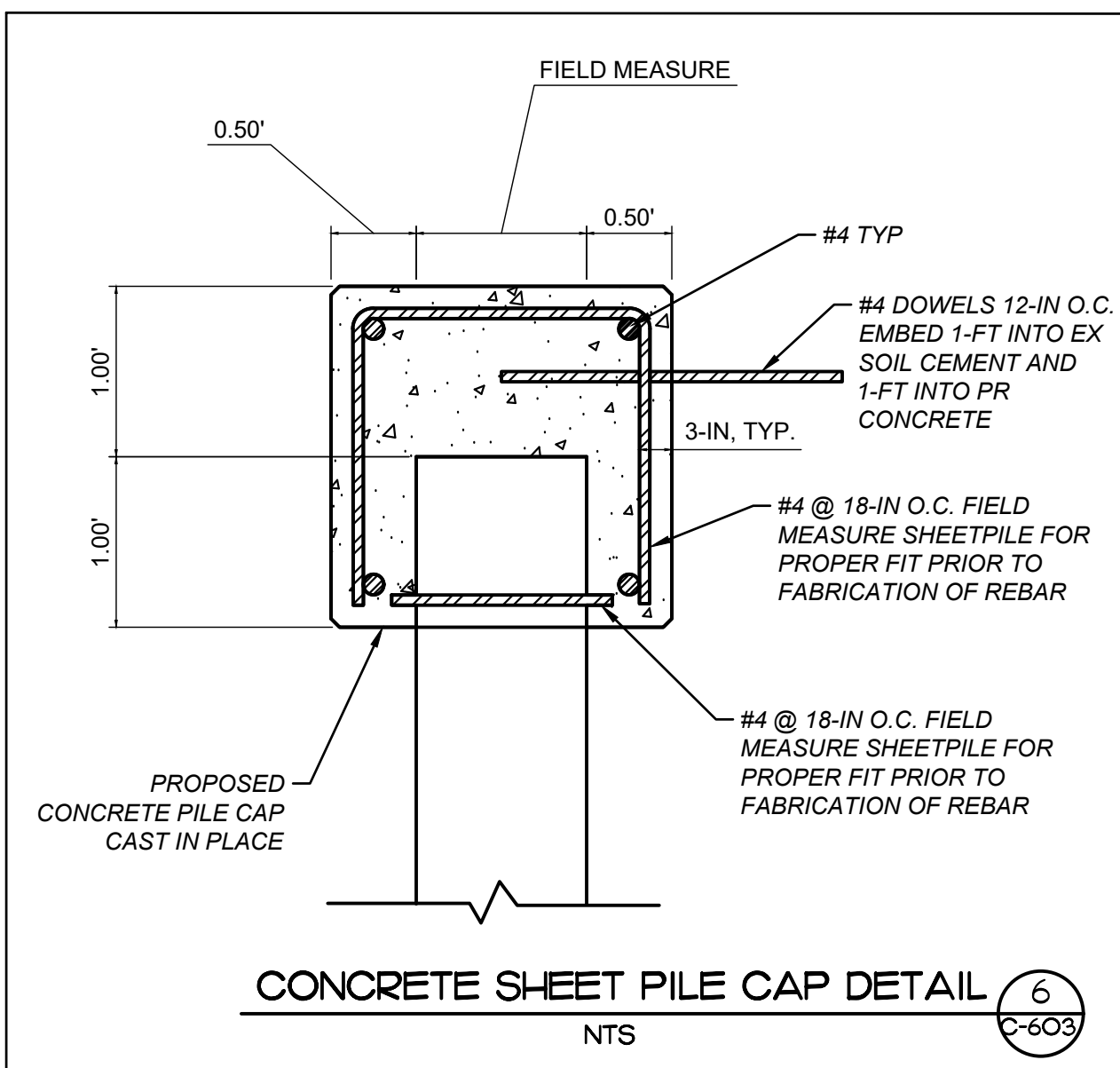
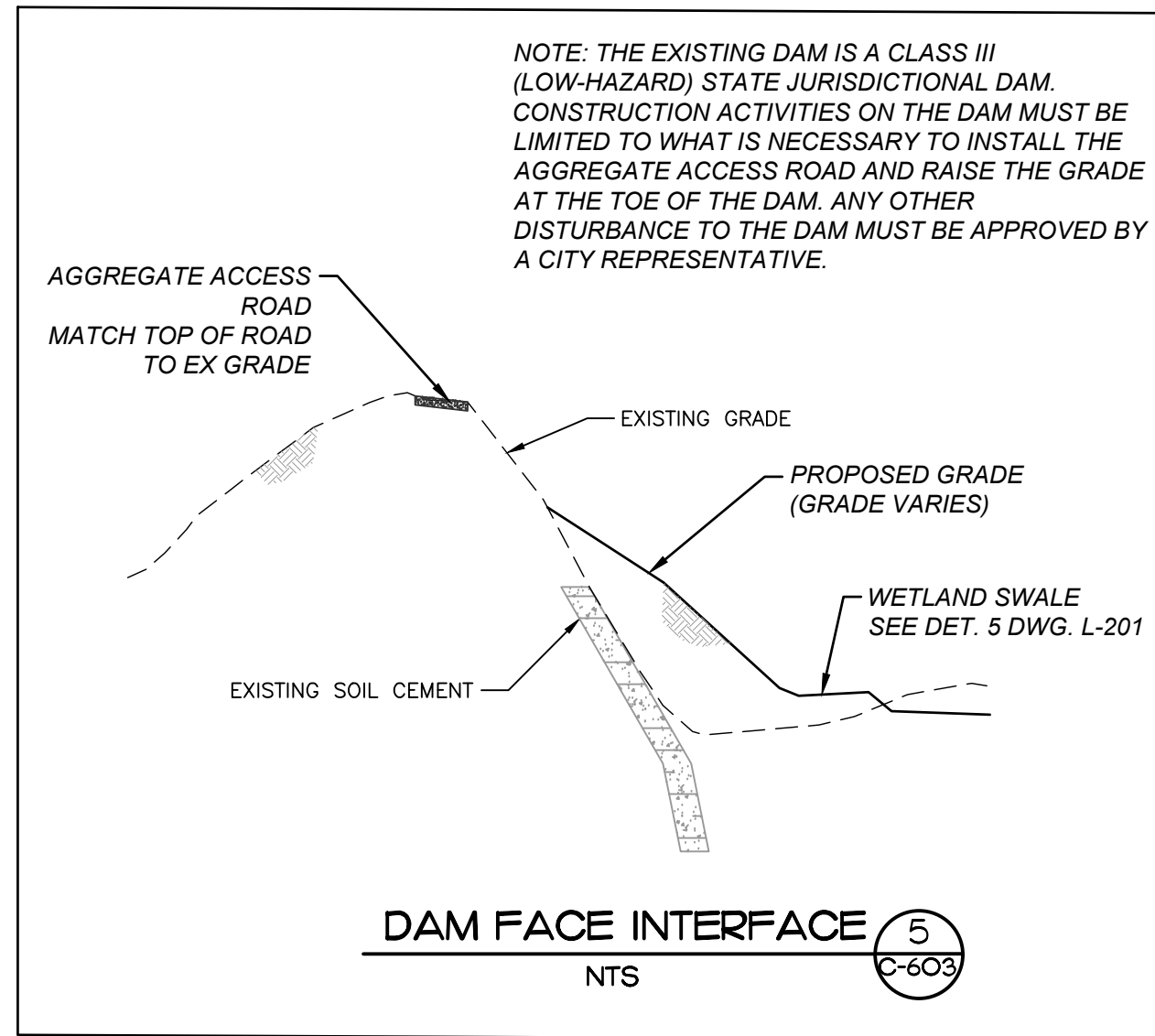
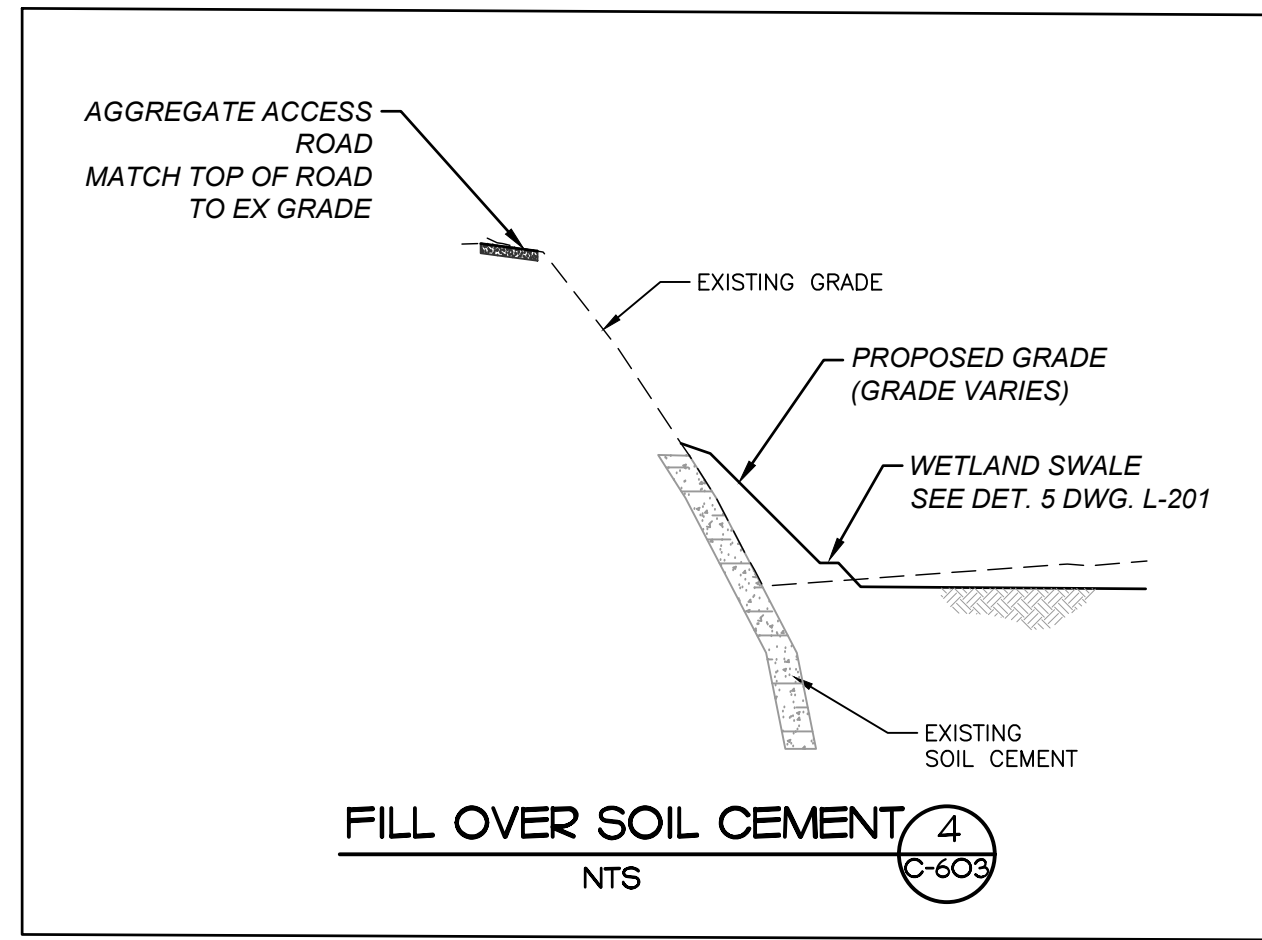

REV	REVISION DESCRIPTION	DATE	CHND	CHKD	APPR



CITY OF COLORADO SPRINGS
 30 S. NEVADA AVE., SUITE 401
 COLORADO SPRINGS, CO 80903
 (719) 385-5980

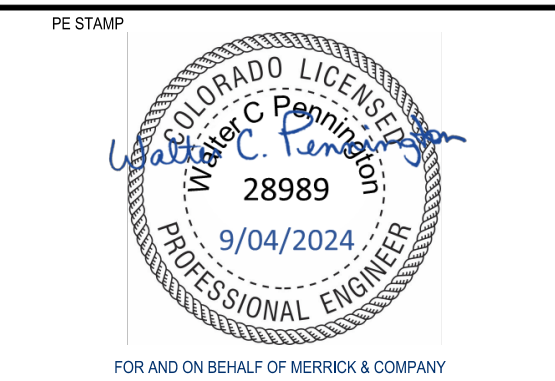

TITLE: SAND CREEK DETENTION POND NO. 2
 CIVIL DETAILS

JOB NUMBER	65420975
DATE	AUGUST 2024
DWG	C-603
SHEET	23 of 51

THE USE OF THIS DRAWING IS LIMITED TO THE PROJECT AND SITE SPECIFICALLY IDENTIFIED THEREON. ANY REUSE OF THIS DRAWING FOR ANY OTHER PROJECT, REUSE OR MODIFICATION OF ANY INFORMATION NOT A PART OF THIS DRAWING IS PROHIBITED WITHOUT THE WRITTEN CONSENT OF MERRICK AND COMPANY. THIS DRAWING IS THE PROPERTY OF MERRICK AND COMPANY AND SHALL BE KEPT IN CONFIDENCE.

File Location: Q:\Denver_North\Projects\City of Colorado Springs\Sand Creek Pond No. 2\CAD\CAD\0975-Flood_Sign_Detail.dwg Plot Date: 8/26/2024 4:41 PM Last Saved By: TIMMCMULLEN

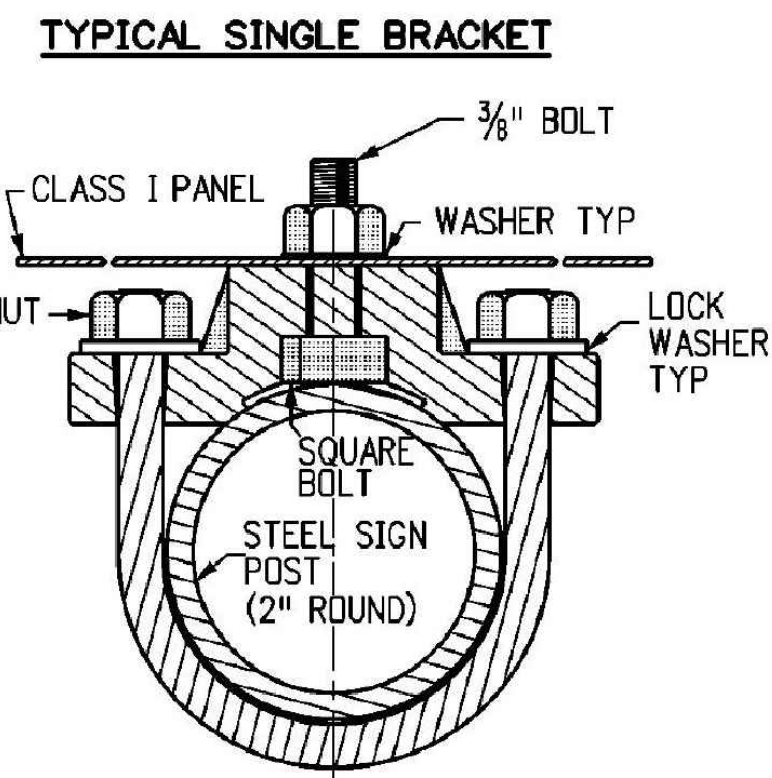

TYPICAL ROUND STEEL POLE SECTION

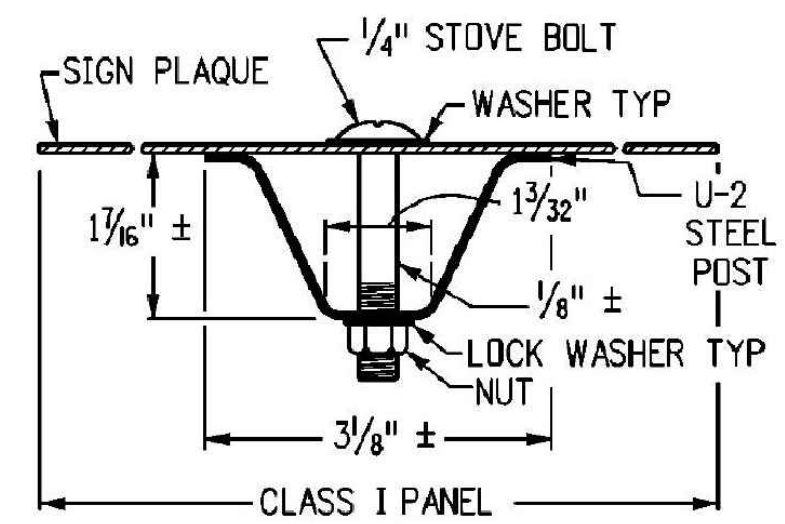

TYPICAL U-2 POST SECTION

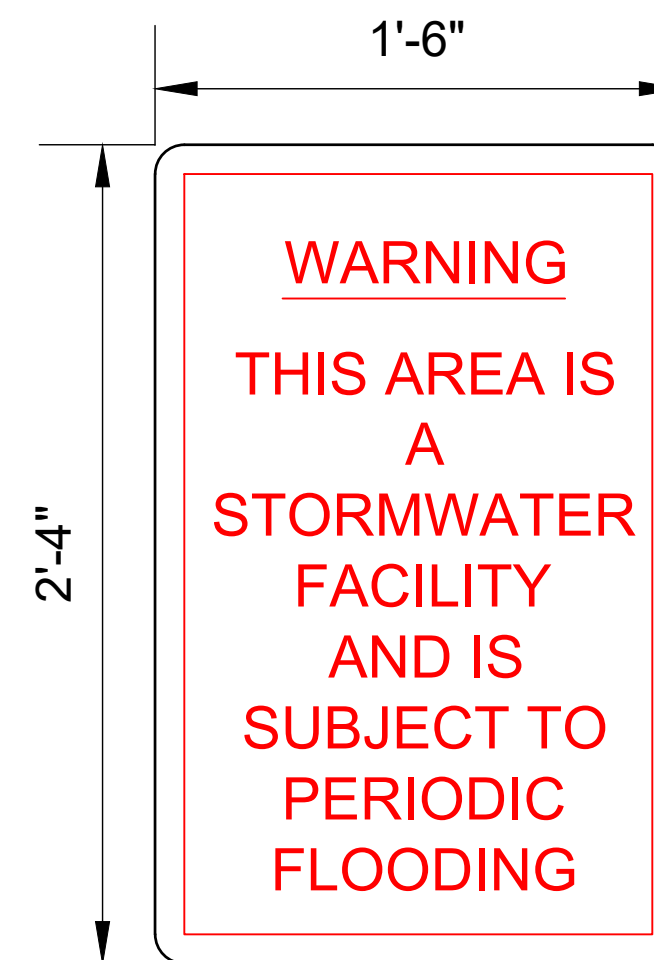

SIGN FACE

GENERAL NOTES

1. TIMBER SIGN POSTS MAY ONLY BE USED FOR TEMPORARY SIGNAGE DURING CONSTRUCTION. TUBULAR STEEL SHALL BE USED FOR PERMANENT INSTALLATIONS.
2. CLASS I SIGN PANELS ARE ALL THOSE THAT DO NOT REQUIRE BACKING ZEES. CLASS I PANELS SHALL GENERALLY BE 0.100" MINIMUM THICKNESS SINGLE SHEET ALUMINUM, BUT 0.080" THICKNESS MAY BE USED FOR SIGN PANELS WHERE BOTH THE HORIZONTAL AND VERTICAL DIMENSIONS ARE LESS THAN 36 IN.
3. CLASS I SIGN PANELS SHALL BE FASTENED TO THE U-2 POST WITH 2- IN. STOVE BOLTS AND TO TIMBER POSTS WITH 2- IN. MACHINE BOLTS. SEE STANDARD PLANS S-614-20 AND S-614-22 FOR EXCEPTIONS.
4. A WASHER SHALL BE PLACED BETWEEN THE BOLT HEAD AND THE FACE OF THE SIGN PANEL. A 1 IN. DIA. WASHER SHALL BE PLACED UNDER THE NUT ON THE BACK OF THE TIMBER POST.
5. BOLTS, NUTS AND WASHERS SHALL BE GALVANIZED OR CADMIUM PLATED.
6. ALL SIGNS SHALL BE FABRICATED USING RETROREFLECTIVE SHEETING CONFORMING TO ASTM D4956.
7. PLACE SIGNS ACCORDING TO PLANS, WITH THE SIGN POST 4' FROM THE NEAREST EDGE OF ACCESS ROAD
8. U-2 POSTS MAY ONLY BE USED FOR DELINEATORS, MILE MARKERS AND STRUCTURE NUMBER PLAQUES. "U" SHAPE STEEL POSTS SHALL BE A UNIFORM FLANGED CHANNEL SECTION MADE FROM HOT ROLLED STRUCTURAL STEEL, RE-ROLLED RAIL STEEL, OR NEW BILLET STEEL HAVING A MINIMUM YIELD STRENGTH OF AT LEAST 30,000 PSI, AND A MINIMUM TENSILE STRENGTH OF AT LEAST 50,000 PSI. "U" SHAPE POSTS SHALL WEIGH 2 LBS/FT, EXCEPT THAT A MILL TOLERANCE OF MINUS 3 % OF THE WEIGHT OF ANY ONE POST WILL BE ALLOWED. "U" SHAPE POSTS SHALL HAVE 1/2 IN. HOLES DRILLED OR PUNCHED ON 1 IN. OR 2 IN. CENTERS FOR THE TOP 4 FEET OF THE POST AS A MINIMUM, WITH THE FIRST HOLE 1 IN. FROM THE TOP OF THE POST. COLOR OF POSTS SHALL BE INTERSTATE GREEN.
9. VERTICAL SPACING BETWEEN PANELS ON THE SAME POST SHALL BE 1 IN. TO 1 IN.
10. SIGNS MUST BE MINIMUM OF 3 SQUARE FEET, FABRICATED OF DURABLE MATERIALS (SUCH AS METAL OR PLASTIC) AND USE RED LETTERING ON A WHITE BACKGROUND.

Computer File Information		Sheet Revisions		Colorado Department of Transportation 2829 W. Howard Pl. Denver, CO 80204 Phone: 303-757-9436 FAX: 303-757-9219 Traffic & Safety Engineering	CLASS I SIGNS Issued By: Traffic & Safety Engineering Branch July 31, 2019	STANDARD PLAN NO.	
Creation Date: 07/04/12		Date:	Comments:			S-614-2	Standard Sheet No. 1 of 1
Created By: KCM				MKB			
Last Modification Date: 07/31/19					Project Sheet Number:		
Last Modified By: EBUTTA							
CAD Ver.: MicroStation V8 Scale: Not to Scale Units: English							

REV	REVISION DESCRIPTION	DATE	CHND	CHKD	APPR

CALL BEFORE YOU DIG

**Know what's below.
Call before you dig.**

CITY OF COLORADO SPRINGS
 30 S. NEVADA AVE., SUITE 401
 COLORADO SPRINGS, CO 80903
 (719) 385-5980

MERRICK®
 Engineering | Architecture | Design-Build | Surveying | Planning | Geospatial Solutions
 2480 W. 26TH AVE., UNIT B225 - DENVER COLORADO 80211
 TEL: 303-751-0741, FAX 303-751-2581
 www.merrick.com

PE STAMP

FOR AND ON BEHALF OF MERRICK & COMPANY

TITLE

SAND CREEK DETENTION POND NO. 2

CIVIL DETAILS

JOB NUMBER

65420975

DATE

AUGUST 2024

DWG



C-604

SHEET

24 of 51

THE USE OF ANY ENGINE, ELECTRONIC, MEASUREMENT OR INSTRUMENTATION IS AN INSTRUMENT OF SERVICE PROVIDED BY ARCHITERRA GROUP, INC. (ARCHITERRA) FOR THIS PROJECT. IT IS NOT INTENDED OR REPRESENTED TO BE SUITABLE FOR REUSE IN WHOLE OR IN PART OR FOR THE EXTENSION OF THE PROJECT OR FOR ANY OTHER PROJECT. REUSE OR MODIFICATION OF ANY INFORMATION NOT A PART OF THIS INSTRUMENT WITHOUT THE WRITTEN CONSENT OF ARCHITERRA GROUP, INC. IS PROHIBITED. ARCHITERRA GROUP, INC. SHALL BE THE SOLE RESPONSIBLE PARTY FOR ANY ERRORS OR OMISSIONS IN THIS DRAWING.

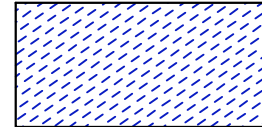
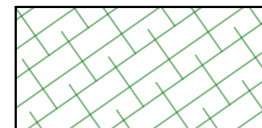
SEEDING AND WETLANDS LEGEND

-  WETLAND PLUGS
-  WETLAND/RIPARIAN SEED
-  UPLAND SEED

WETLAND PLUG SCHEDULE

QTY	LATIN NAME	COMMON NAME	SIZE	REMARKS
4,410	<i>Carex aquatilis</i>	Water sedge	10 cu. in. plug	98 ct. flat
4,410	<i>Carex emoryi</i>	Emory sedge	10 cu. in. plug	98 ct. flat
4,312	<i>Carex nebrascensis</i>	Nebraska sedge	10 cu. in. plug	98 ct. flat
4,312	<i>Carex pellita (lanuginosa)</i>	Woolly sedge	10 cu. in. plug	98 ct. flat
4,312	<i>Distichlis spicata</i>	Inland saltgrass	10 cu. in. plug	98 ct. flat
4,312	<i>Eleocharis palustris</i>	Common spikerush	10 cu. in. plug	98 ct. flat
4,312	<i>Juncus articus</i>	Baltic rush	10 cu. in. plug	98 ct. flat
4,312	<i>Juncus torreyi</i>	Torrey's rush	10 cu. in. plug	98 ct. flat
4,312	<i>Panicum virgatum</i>	Switchgrass	10 cu. in. plug	98 ct. flat
4,312	<i>Schoenoplectus acutus</i>	Hardstem bulrush	10 cu. in. plug	98 ct. flat
4,312	<i>Schoenoplectus tabernaemontani</i>	Softstem bulrush	10 cu. in. plug	98 ct. flat
4,312	<i>Scirpus pungens</i>	Common three-square	10 cu. in. plug	98 ct. flat
4,312	<i>Scirpus microcarpus</i>	Panicled bulrush	10 cu. in. plug	98 ct. flat
4,312	<i>Spartina pectinate</i>	Prairie cordgrass	10 cu. in. plug	98 ct. flat

- NOTES:**
- RIP AND RESEED CONSTRUCTION ACCESS ROUTES.
 - COORDINATE WITH OWNER'S REPRESENTATIVE FOR LOCATIONS OF SEED AND WETLANDS.
 - SEE WETLAND PLUG SCHEDULE (THIS SHEET) FOR WETLAND PLUGS. SEE SPECIFICATIONS FOR SEED MIXES.
 - WETLAND LAYOUT MAY NEED TO BE ADJUSTED BASED ON SOIL HYDROLOGY AFTER CONSTRUCTION. COORDINATE LAYOUT WITH OWNER'S REPRESENTATIVE.
 - WETLAND PLUGS SHALL BE PLANTED IN GROUPINGS OF NO LESS THAN 100 OF THE SAME SPECIES. THE INTENT IS TO CREATE A NATURAL CHARACTER BY PLANTING ORGANICALLY SHAPED GROUPINGS OF WETLAND PLANTS, RATHER THAN RIGID, GEOMETRIC GROUPS OF PLANTS. COORDINATE WITH OWNER'S REPRESENTATIVE FOR LAYOUT.
 - AN ADDITIONAL 12 FLATS OF WETLAND PLUGS (1,176 PLUGS) WILL BE INSTALLED IN GROUPINGS OF 30-40 THROUGHOUT AREAS COVERED BY THE WETLAND/RIPARIAN SEED MIX. COORDINATE WITH OWNER'S REPRESENTATIVE FOR LOCATIONS.

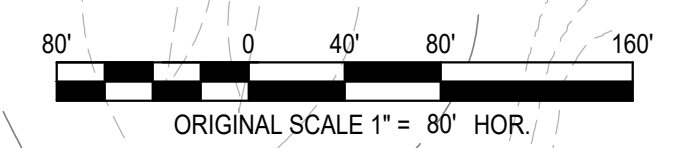
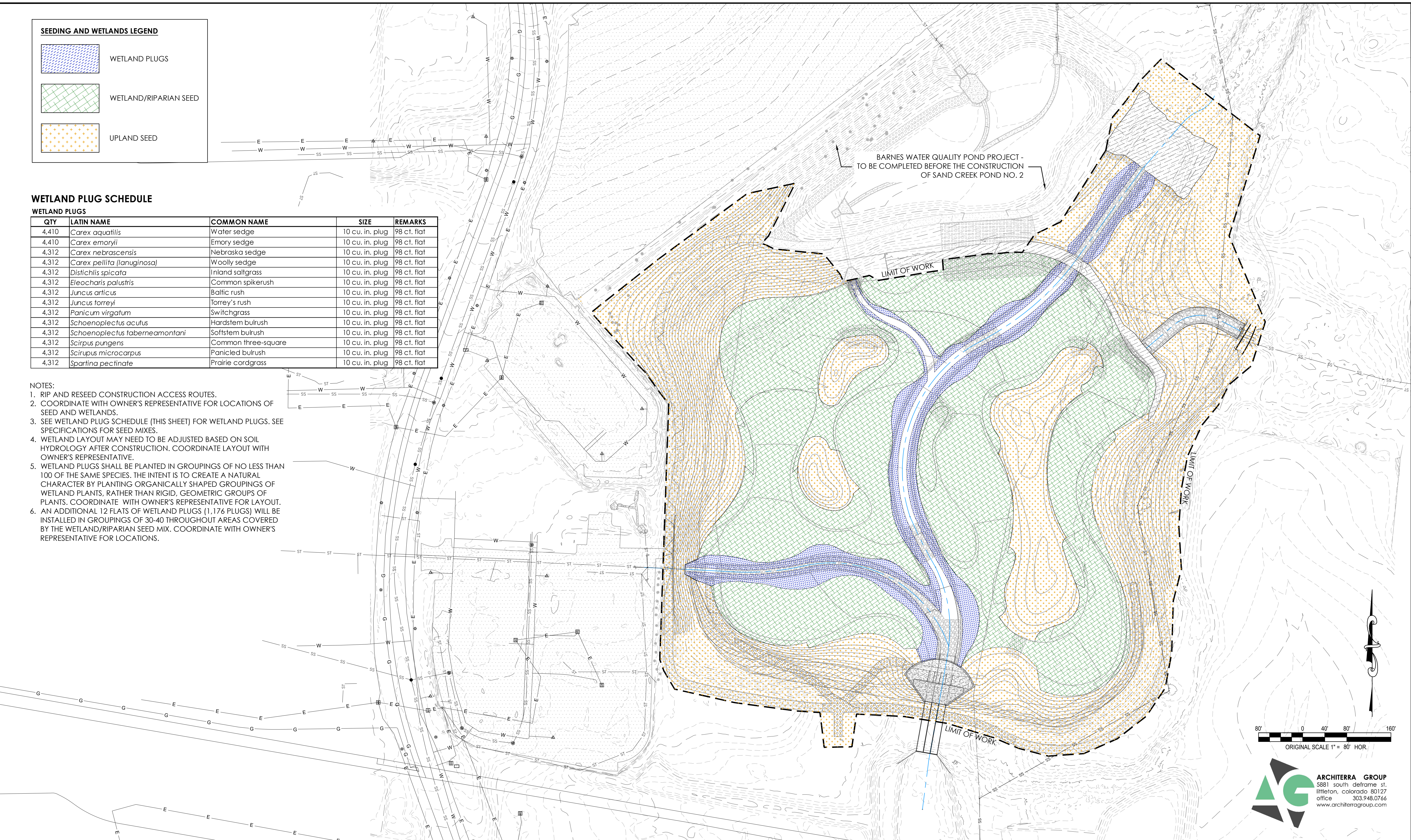

ARCHITERRA GROUP
 5881 south deframe st.
 littleton, colorado 80127
 office 303.948.0766
 www.architerragroup.com

File Location: \\projects\1105-Sand Creek Pond #2\Drawings - Technical\Construction Drawings\1105-Sand Creek Pond #2.DWG Plot Date: 8/22/2024 5:20 PM Last Saved By: MTALEFRICO

REV	REVISION DESCRIPTION	DATE	CHND	CHKD	APPR



811
 Know what's below.
 Call before you dig.

CITY OF COLORADO SPRINGS
 30 S. NEVADA AVE., SUITE 401
 COLORADO SPRINGS, CO 80903
 (719) 385-5980



MERRICK
 Engineering | Architecture | Design-Build | Surveying | Planning | Geospatial Solutions
 2480 W. 26TH AVE., UNIT B225 - DENVER COLORADO 80211
 TEL. 303-751-0741, FAX 303-751-2581
 www.merrick.com



SAND CREEK DETENTION POND NO. 2

SEEDING AND WETLAND PLUGS PLAN

JOB NUMBER: 65420975
 DATE: AUGUST 2024
 DRAWING: L-100
 25 of 51

THE ANY OTHER EXISTING UTILITIES, ENCUMBRANCES, OR OBSTRUCTIONS, INCLUDING BUT NOT LIMITED TO, POWER, GAS, WATER, TELEPHONE, CABLE, OR OTHER SERVICES, ARE SHOWN ON THIS PLAN AS APPROXIMATE LOCATIONS ONLY. THE CONTRACTOR SHALL VERIFY THE LOCATION AND DEPTH OF ALL UTILITIES PRIOR TO CONSTRUCTION. THE CONTRACTOR SHALL BE RESPONSIBLE FOR OBTAINING ALL NECESSARY PERMITS AND APPROVALS FROM THE APPROPRIATE AGENCIES. THE CONTRACTOR SHALL BE RESPONSIBLE FOR PROTECTING ALL EXISTING UTILITIES AND OBSTRUCTIONS. THE CONTRACTOR SHALL BE RESPONSIBLE FOR OBTAINING ALL NECESSARY PERMITS AND APPROVALS FROM THE APPROPRIATE AGENCIES. THE CONTRACTOR SHALL BE RESPONSIBLE FOR PROTECTING ALL EXISTING UTILITIES AND OBSTRUCTIONS.

- NOTES:**
1. LOCATION OF ALL PLANTS WILL BE APPROVED BY OWNER'S REPRESENTATIVE IN THE FIELD PRIOR TO PLANTING. CONTRACTOR SHALL STAKE TREE LOCATIONS AND LAY POTTED PLANTS ON SITE AT PROPOSED LOCATIONS FOR APPROVAL BY OWNER'S REPRESENTATIVE.
 2. SEE L-102 FOR PLANT SCHEDULE.
 3. SEE L-201 FOR PLANTING DETAILS.

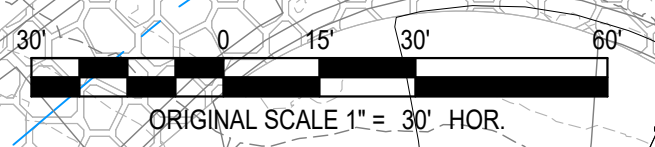
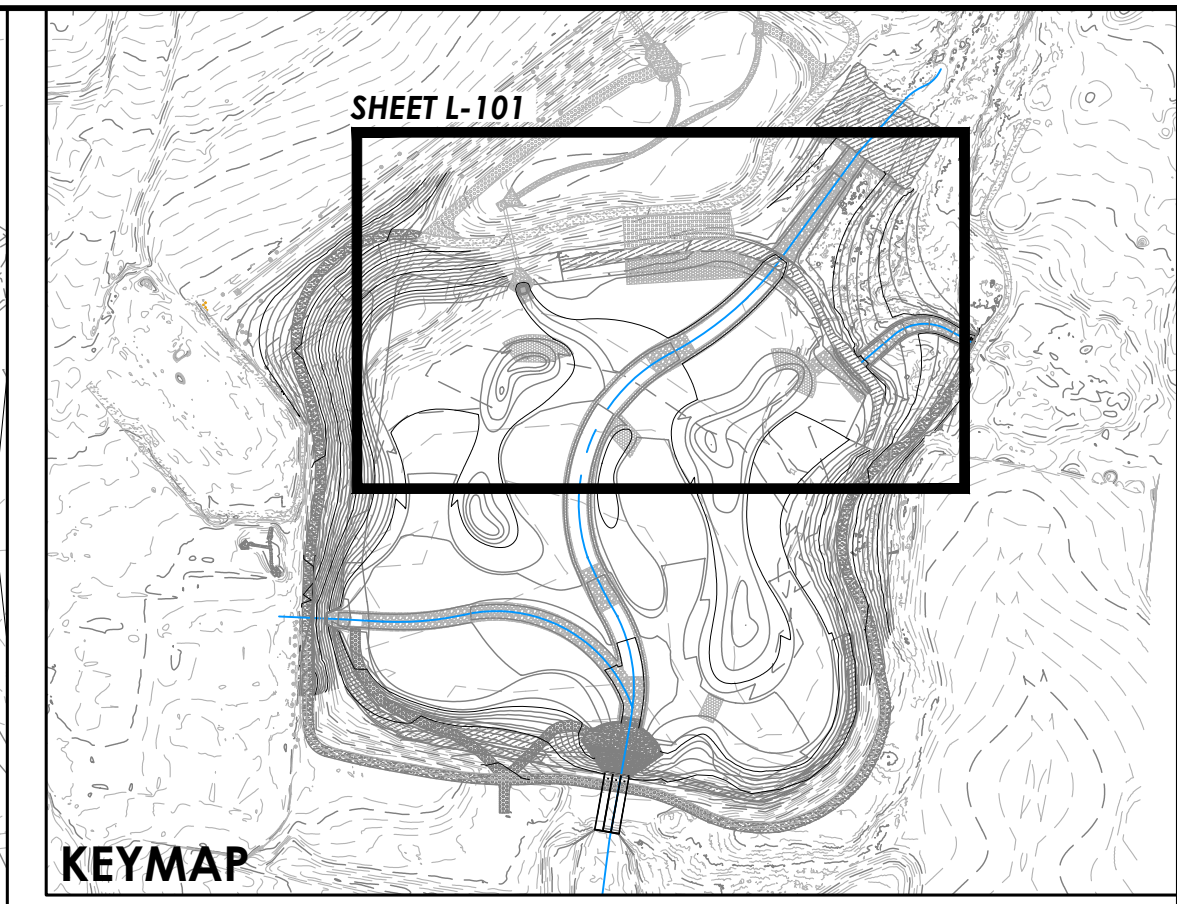
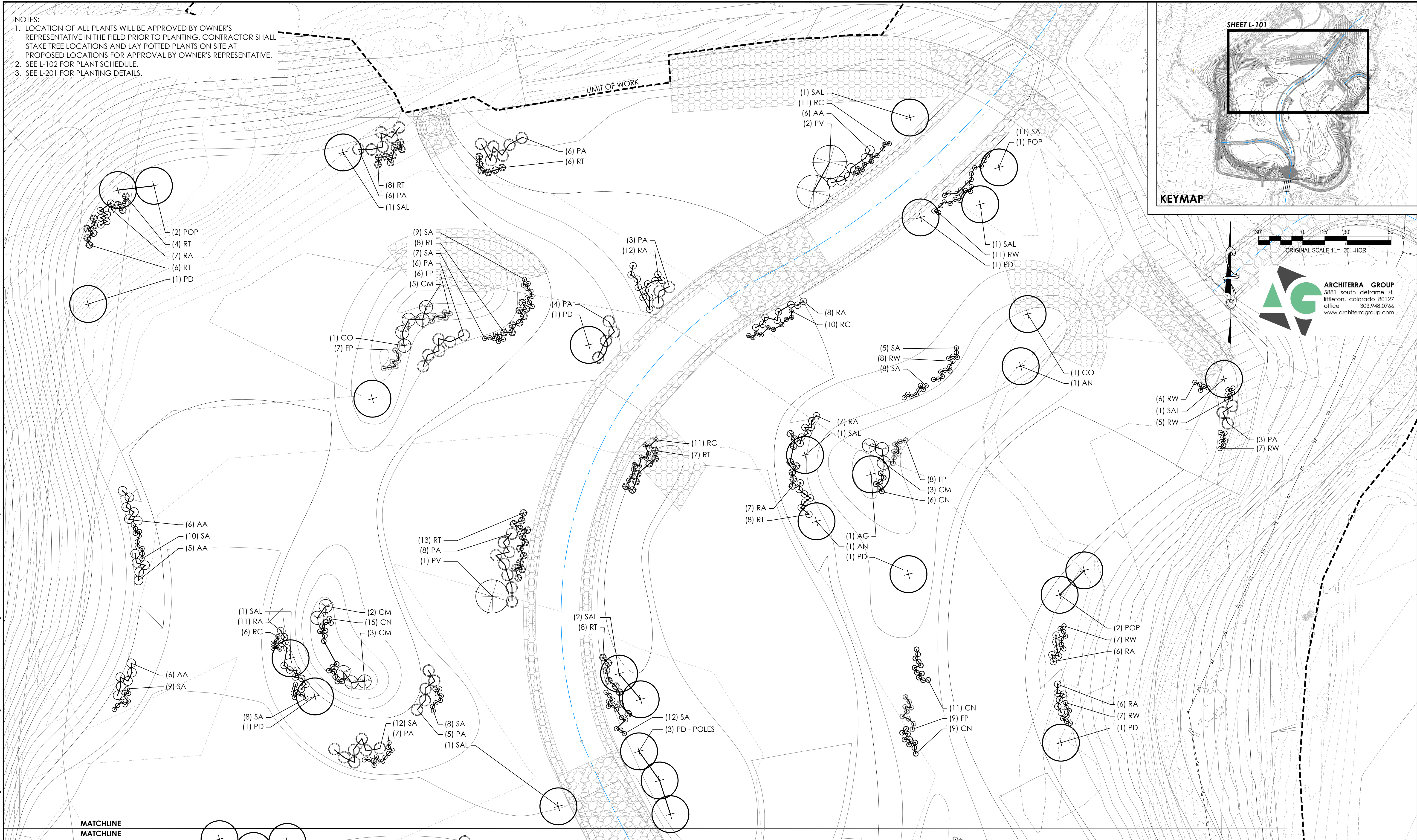

MATCHLINE
MATCHLINE



CITY OF COLORADO SPRINGS
 30 S. NEVADA AVE., SUITE 401
 COLORADO SPRINGS, CO 80903
 (719) 385-5980

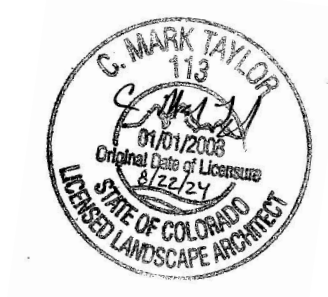

SAND CREEK DETENTION POND NO. 2

PLANTING PLAN

JOB NUMBER	65420975
DATE	AUGUST 2024
DRAWING	L-101
26 of 51	178 of 507

REV	REVISION DESCRIPTION	DATE	CHND	CHKD	APPR

THIS AND ALL OTHERS ARE THE PROPERTY OF ARCHITERRA GROUP, INC. AND SHALL REMAIN THE PROPERTY OF ARCHITERRA GROUP, INC. ANY REUSE OR MODIFICATION OF ANY INFORMATION IS NOT A FINISHED INSTRUMENT. WITHOUT THE WRITTEN CONSENT OF ARCHITERRA GROUP, INC. NO PART OF THIS DRAWING SHALL BE REPRODUCED OR TRANSMITTED IN ANY FORM OR BY ANY MEANS, ELECTRONIC OR MECHANICAL, INCLUDING PHOTOCOPYING, RECORDING, OR BY ANY INFORMATION STORAGE AND RETRIEVAL SYSTEM.

File Location: \\projects\12106-Sand Creek Pond #2\Drawings - Technical\Construction Drawings\12106 - Sand Creek Pond #2.DWG Plot Date: 8/22/2024 5:22 PM Last Saved By: MTALEFRICO

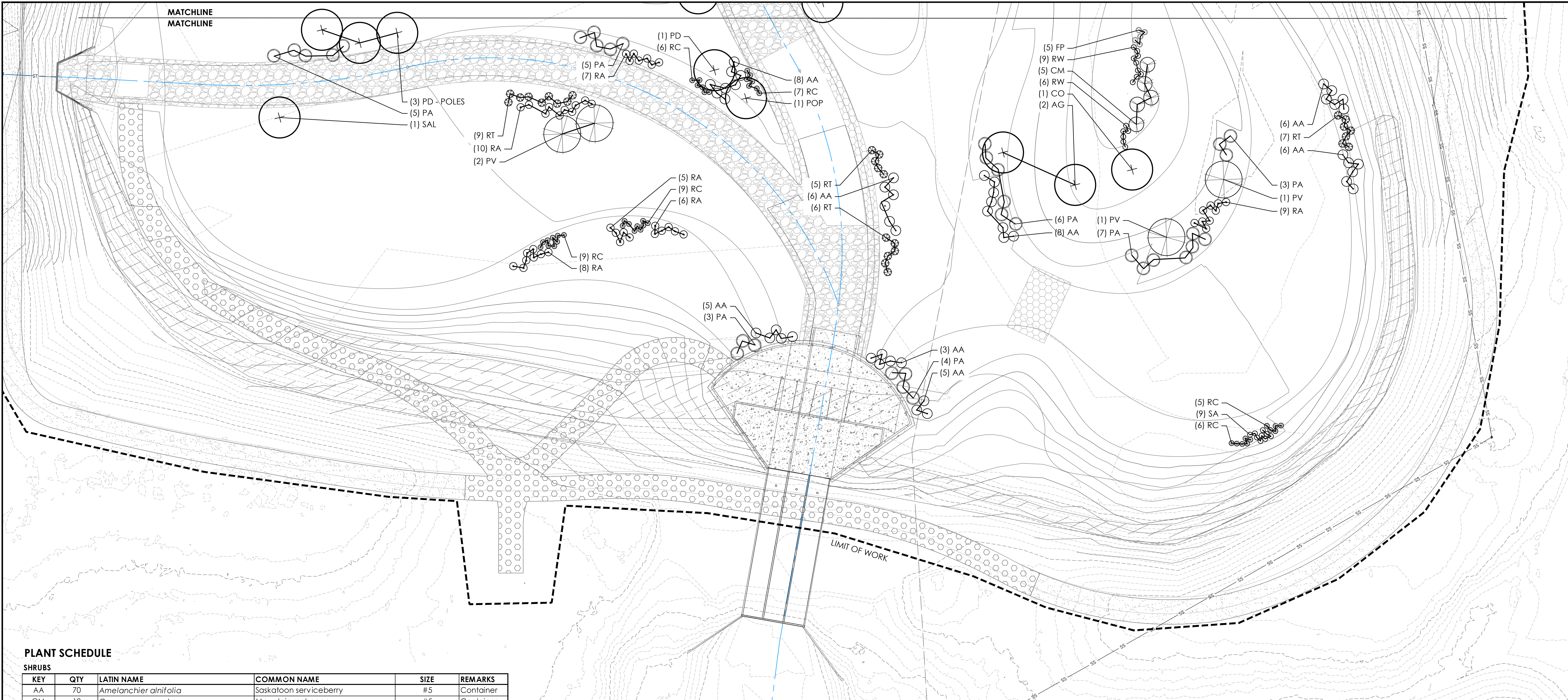

PLANT SCHEDULE

SHRUBS

KEY	QTY	LATIN NAME	COMMON NAME	SIZE	REMARKS
AA	70	<i>Amelanchier alnifolia</i>	Saskatoon serviceberry	#5	Container
CM	18	<i>Cercocarpus montanus</i>	Mountain mahogany	#5	Container
CN	41	<i>Chrysothamnus nauseosus</i>	Rubber rabbitbrush	#5	Container
FP	35	<i>Fallugia paradoxa</i>	Apache plume	#5	Container
PA	81	<i>Prunus americana</i>	Wild plum	#5	Container
PV	7	<i>Prunus virginiana</i>	Chokecherry	#5	Container
RT	95	<i>Rhus trilobata</i>	Skunkbrush sumac	#5	Container
RA	109	<i>Ribes aureum</i>	Golden currant	#5	Container
RC	80	<i>Ribes cereum</i>	Wax currant	#5	Container
RW	66	<i>Rosa woodsii</i>	Wood's rose	#5	Container
SA	108	<i>Symphoricarpos albus</i> or <i>S. occidentalis</i>	Snowberry	#5	Container

TREES

KEY	QTY	LATIN NAME	COMMON NAME	SIZE	REMARKS
AG	3	<i>Acer glabrum</i>	Rocky Mountain Maple	2" Caliper	B&B
AN	2	<i>Acer negundo</i>	Box Elder	2" Caliper	B&B
CO	3	<i>Celtis occidentalis</i>	Common Hackberry	2" Caliper	B&B
POP	6	<i>Populus angustifolia</i>	Narrow-leaved cottonwood	2" Caliper	B&B
PD	7	<i>Populus deltoides monilifera</i>	Plains cottonwood	2" Caliper	B&B
PD	6	<i>Populus deltoides monilifera</i>	Plains cottonwood	Live cutting	Poles
SAL	10	<i>Salix amygdaloides</i>	Peachleaf willow	2" Caliper	B&B

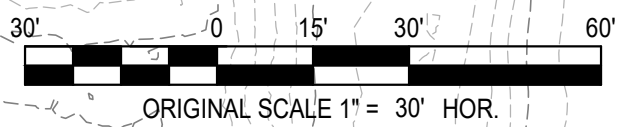

- NOTES:**
1. LOCATION OF ALL PLANTS WILL BE APPROVED BY OWNER'S REPRESENTATIVE IN THE FIELD PRIOR TO PLANTING. CONTRACTOR SHALL STAKE TREE LOCATIONS AND LAY POTTED PLANTS ON SITE AT PROPOSED LOCATIONS FOR APPROVAL BY OWNER'S REPRESENTATIVE.
 2. SEE L-201 FOR PLANTING DETAILS.

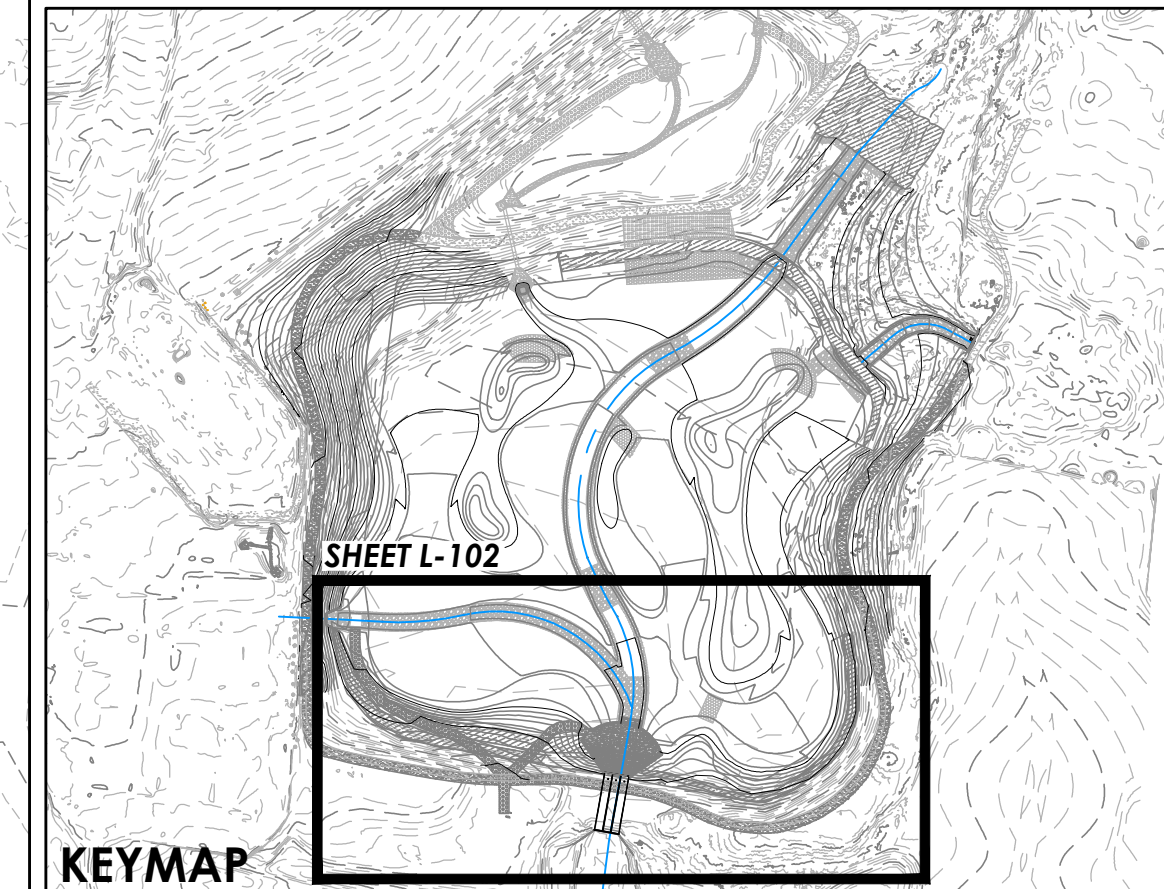

REV	REVISION DESCRIPTION	DATE	CHND	CHKD	APPR

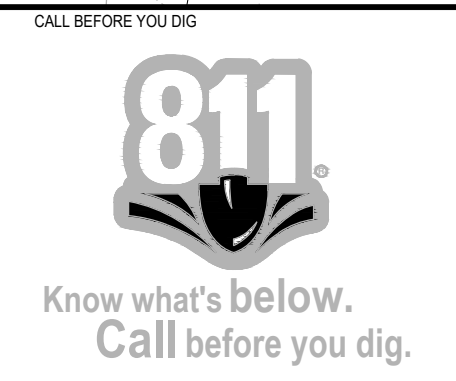

CITY OF COLORADO SPRINGS
 30 S. NEVADA AVE., SUITE 401
 COLORADO SPRINGS, CO 80903
 (719) 385-5980

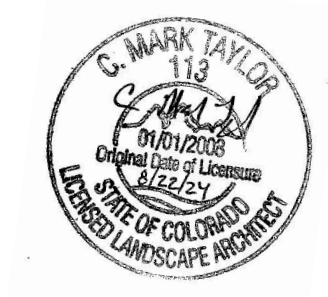

SAND CREEK DETENTION POND NO. 2

PLANTING PLAN

JOB NUMBER	65420975
DATE	AUGUST 2024
DRAWING	L-102
27	of 51

THE ANY, CIVIL, ELECTRICAL, MECHANICAL, PLUMBING, OR ANY INSTRUMENT OF SERVICE, PROVIDED BY ARCHITERRA AND COMPANY, FOR A DESIGN PROJECT, REUSE OR MODIFICATION OF ANY INSTRUMENT OR REPRESENTATION TO BE SUITABLE FOR REUSE IN WHOLE OR IN PART OR EXTENSION OF THE PROJECT OR ON ANY OTHER PROJECT. REUSE OR MODIFICATION OF ANY INSTRUMENT OR REPRESENTATION SHALL BE AT THE USER'S RISK AND WITHOUT LIABILITY TO ARCHITERRA AND COMPANY.

File Location: C:\projects\105-Sand Creek Pond #2 Drawings - Technical\Construction Drawings\2106 - Sand Creek Pond #2 Details.dwg Plot Date: 8/22/2024 4:29 PM Last Saved By: MTALEIRICO

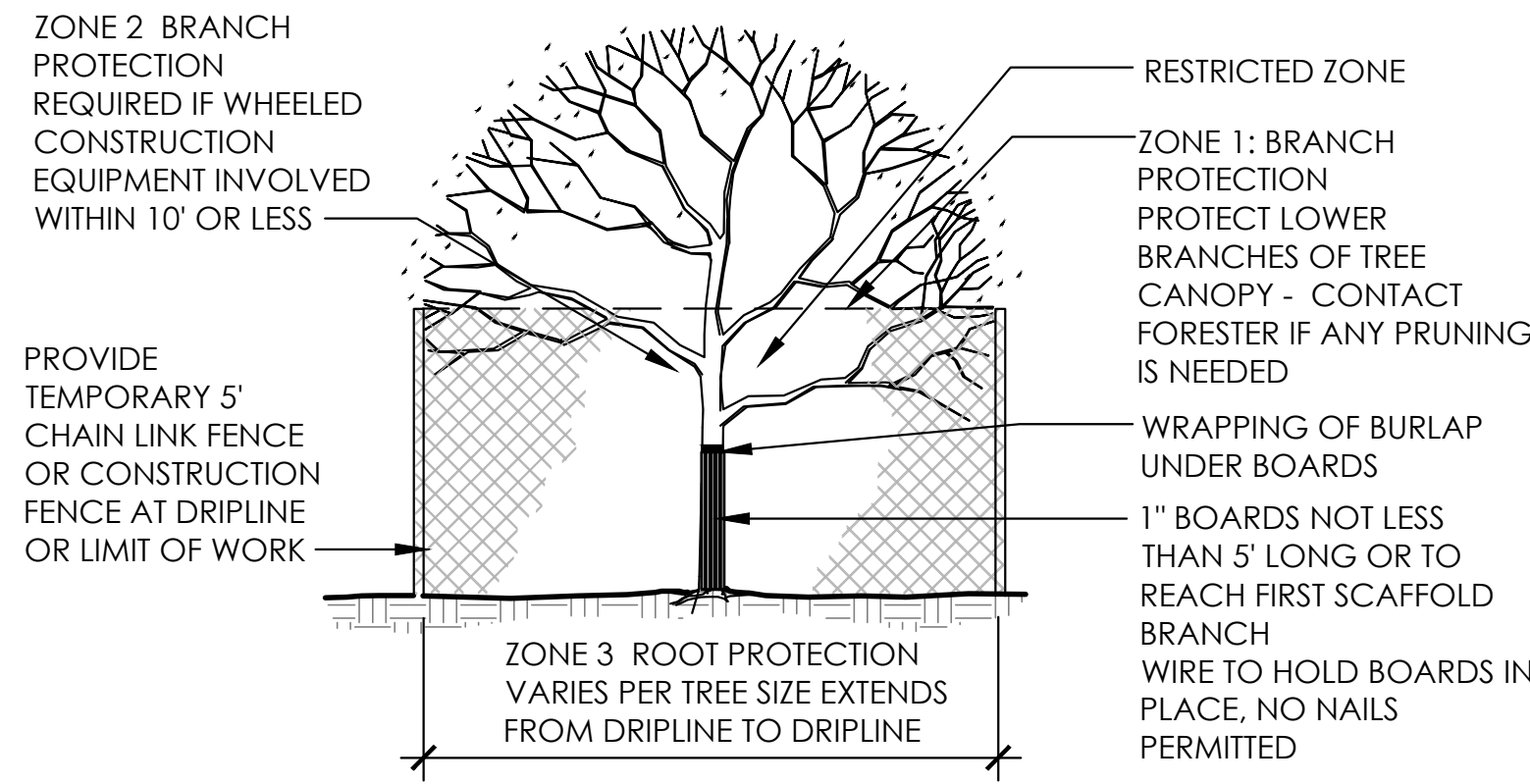

- NOTES:
1. ALL TREES TO RECEIVE ZONE 1, 2, & 3 PROTECTION.
 2. PROVIDE LARGEST PROTECTION ZONE BY EITHER USING DRIP LINE OR 1' Ø PER 1" DIAMETER AT BREAST HEIGHT (DBH), WHICHEVER IS LARGER.

1 TREE PROTECTION FENCING SECTION / ELEVATION NTS

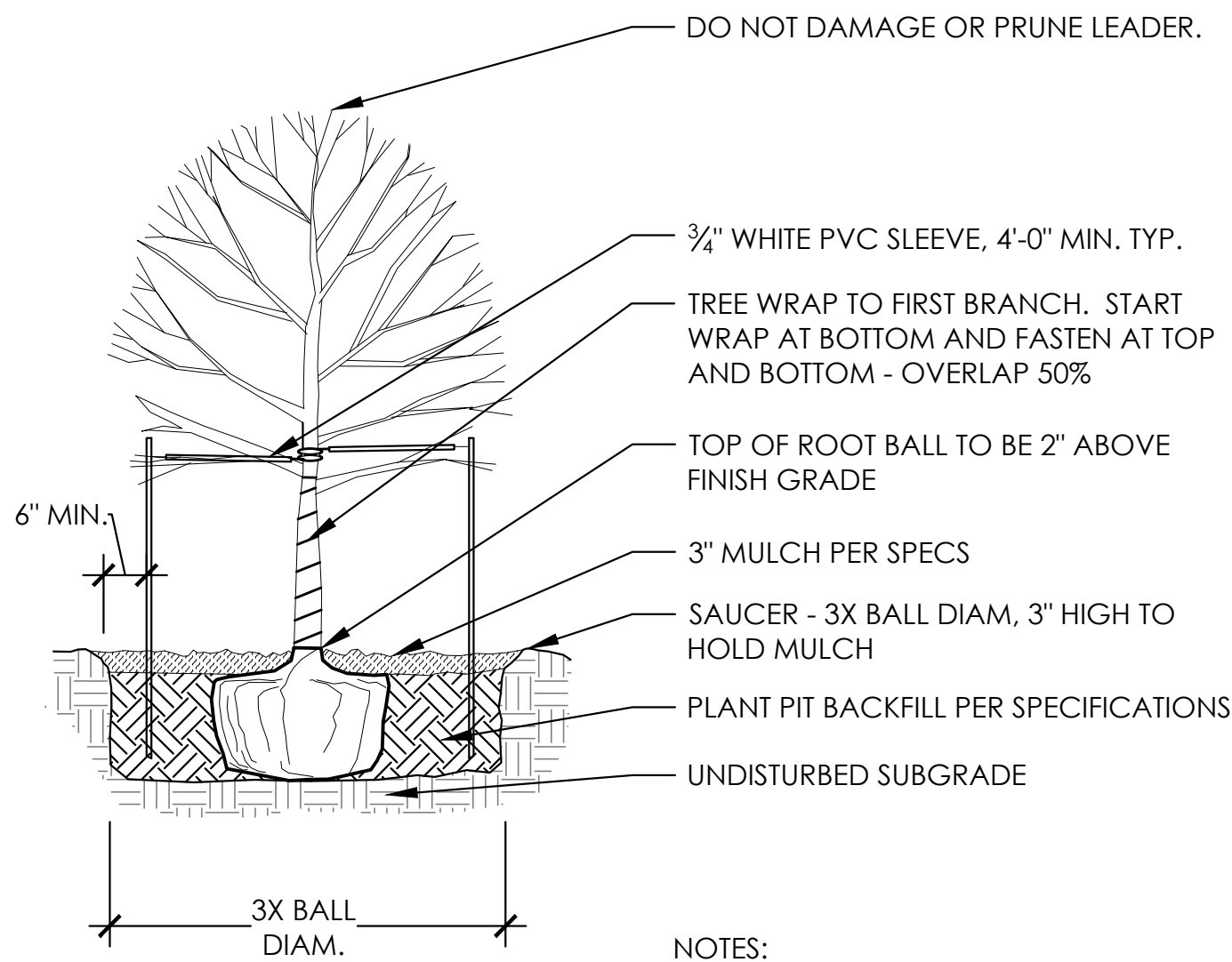

- NOTES:
1. SEE SPECS FOR ADDITIONAL PLANTING REQUIREMENTS.
 2. AFTER PLANT IS SET IN PLANT PIT, CUT AWAY AND REMOVE ALL WIRE AND OTHER RESTRAINING MATERIAL. TAKE CARE NOT TO DAMAGE ROOT BALL. FOLD BURLAP AWAY FROM THE TOP OF THE ROOTBALL.
 3. PLUMB AND ORIENT PLANTS FOR BEST APPEARANCE.

2 DECIDUOUS TREE PLANTING SECTION / ELEVATION NTS

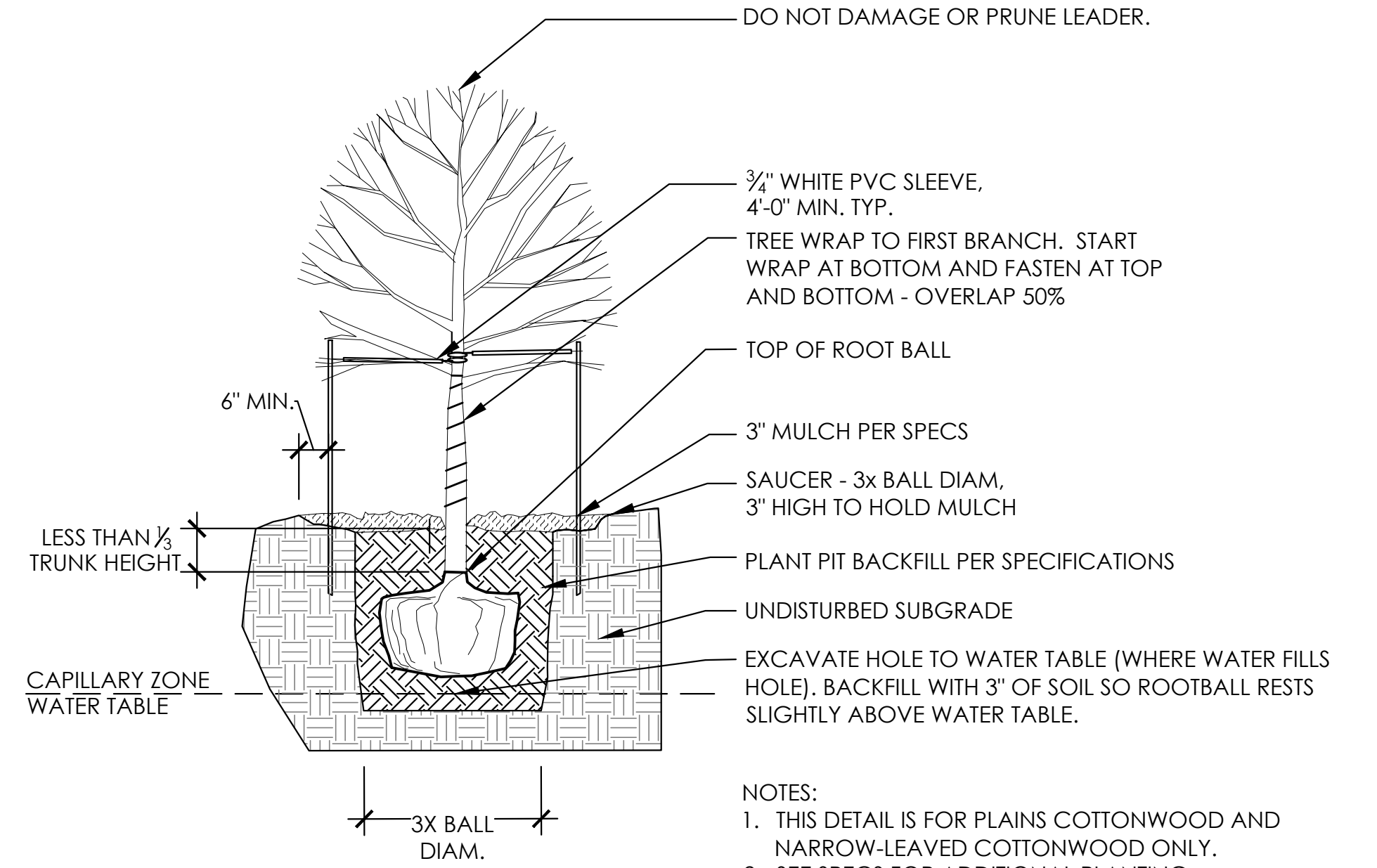

- NOTES:
1. THIS DETAIL IS FOR PLAINS COTTONWOOD AND NARROW-LEAVED COTTONWOOD ONLY.
 2. AFTER PLANT IS SET IN PLANT PIT, CUT AWAY AND REMOVE ALL WIRE AND OTHER RESTRAINING MATERIAL. TAKE CARE NOT TO DAMAGE ROOT BALL. FOLD BURLAP AWAY FROM THE TOP OF THE ROOTBALL.
 3. PLUMB AND ORIENT PLANTS FOR BEST APPEARANCE.

3 DEEP COTTONWOOD TREE PLANTING SECTION / ELEVATION NTS

- NOTES:
1. SEE SPECS FOR ADDITIONAL PLANTING REQUIREMENTS.
 2. AFTER PLANT IS SET IN PLANT PIT, CUT AWAY AND REMOVE ALL WIRE AND OTHER RESTRAINING MATERIAL. TAKE CARE NOT TO DAMAGE ROOT BALL. FOLD BURLAP AWAY FROM THE TOP OF THE ROOTBALL.
 3. PLUMB AND ORIENT PLANTS FOR BEST APPEARANCE.

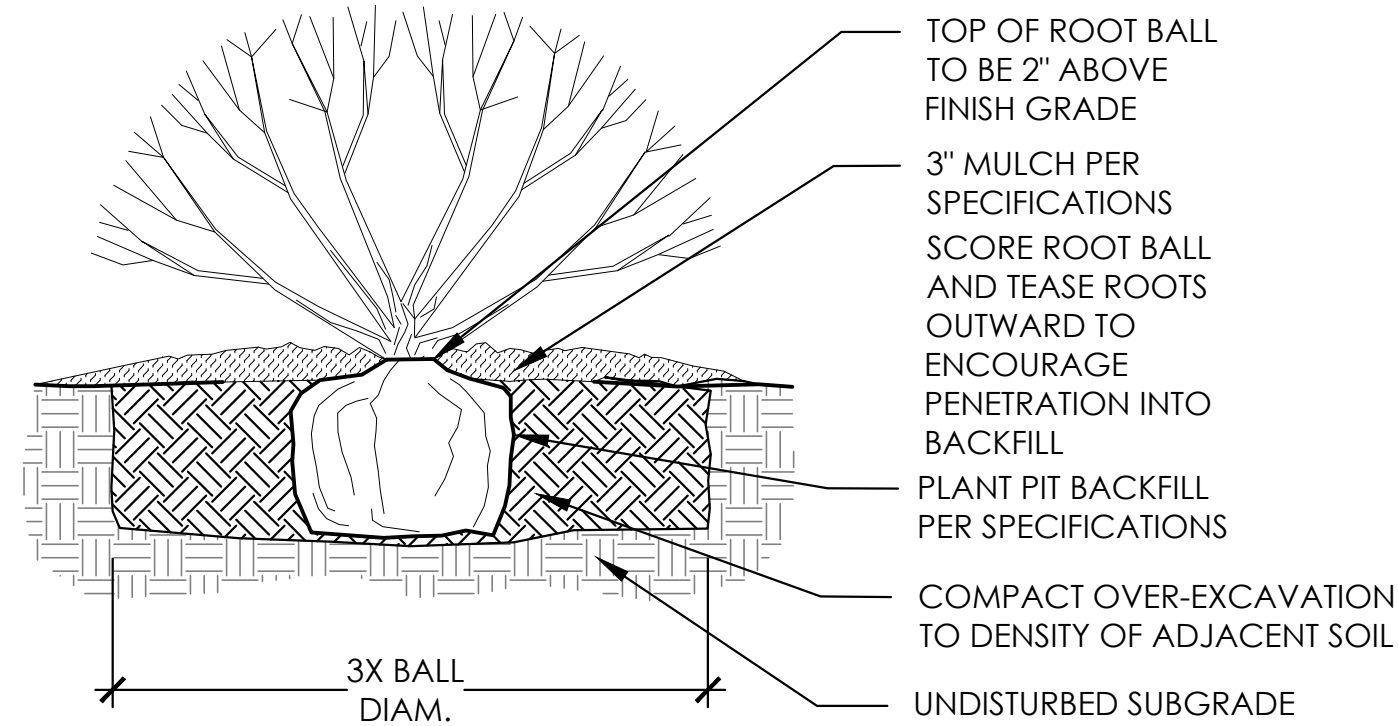

4 SHRUB PLANTING SECTION / ELEVATION NTS

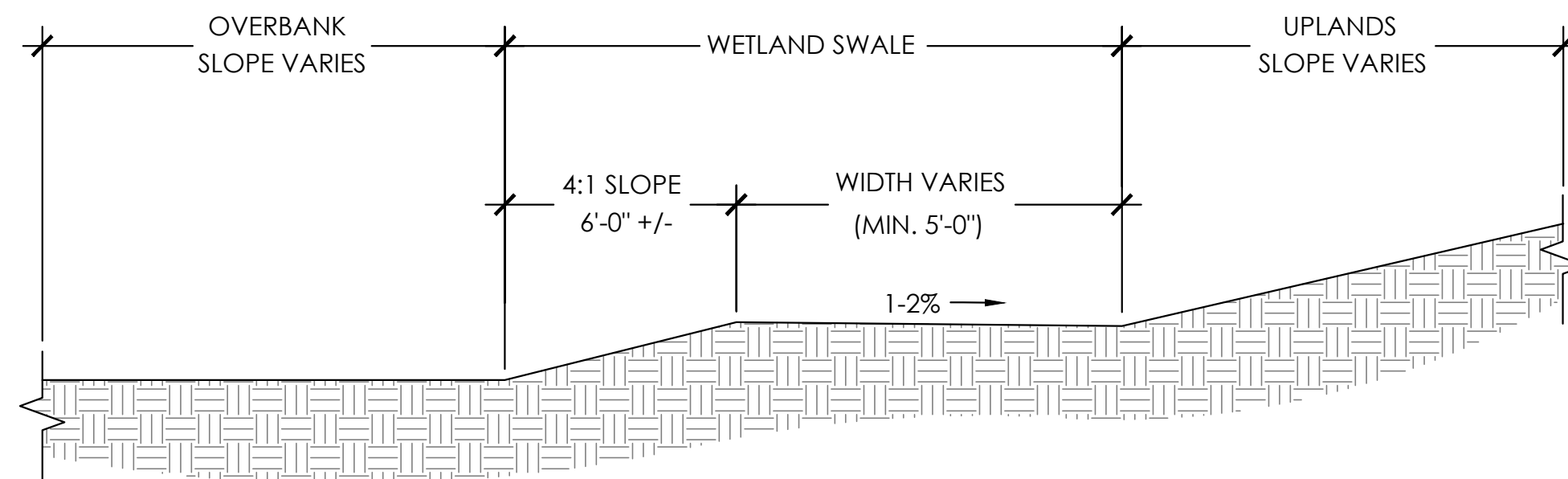

- NOTES:
1. THE DESIGN INTENT IS FOR THE WETLAND SWALES TO SLOW SURFACE WATER AND ENCOURAGE INFILTRATION INTO THE SOIL ALONG THE WETLAND SWALE BY MOVING WATER BACK TOWARDS THE UPLAND SLOPE AREAS.
 2. WETLAND SWALES SHOULD NOT HOLD WATER AND ARE DESIGNED TO DRAIN TO LOW POINTS. SEE GRADING PLANS FOR MORE INFORMATION.
 3. WETLAND SWALES TO HAVE LONGITUDINAL SLOPE OF APPROXIMATELY 1%, GENERALLY DRAINING NORTH TO SOUTH.

5 TYPICAL WETLAND SWALE SECTION NTS



REV	REVISION DESCRIPTION	DATE	CHND	CHKD	APPR



CITY OF COLORADO SPRINGS
 30 S. NEVADA AVE., SUITE 401
 COLORADO SPRINGS, CO 80903
 (719) 385-5980

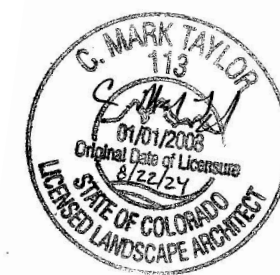

SAND CREEK DETENTION POND NO. 2

PLANTING DETAILS

JOB NUMBER	65420975
DATE	AUGUST 2024
DRAWING	L-201
28	of 51

THE USE OF THIS DRAWING IS LIMITED TO THE PROJECT AND SITE SPECIFICALLY IDENTIFIED HEREIN. ANY REUSE OF THIS DRAWING FOR ANY OTHER PROJECT, IN WHOLE OR IN PART, WITHOUT THE WRITTEN CONSENT OF MERRICK AND COMPANY SHALL BE AT THE USER'S SOLE RISK AND WITHOUT LIABILITY TO MERRICK AND COMPANY.

File Location: \\projects\2106-Sand Creek Pond #2 Drawings - Technical\Construction Drawings\2106 - Sand Creek Pond #2 Architectural Details.dwg Plot Date: 8/22/2024 4:52 PM Last Saved By: MT-ALERICO

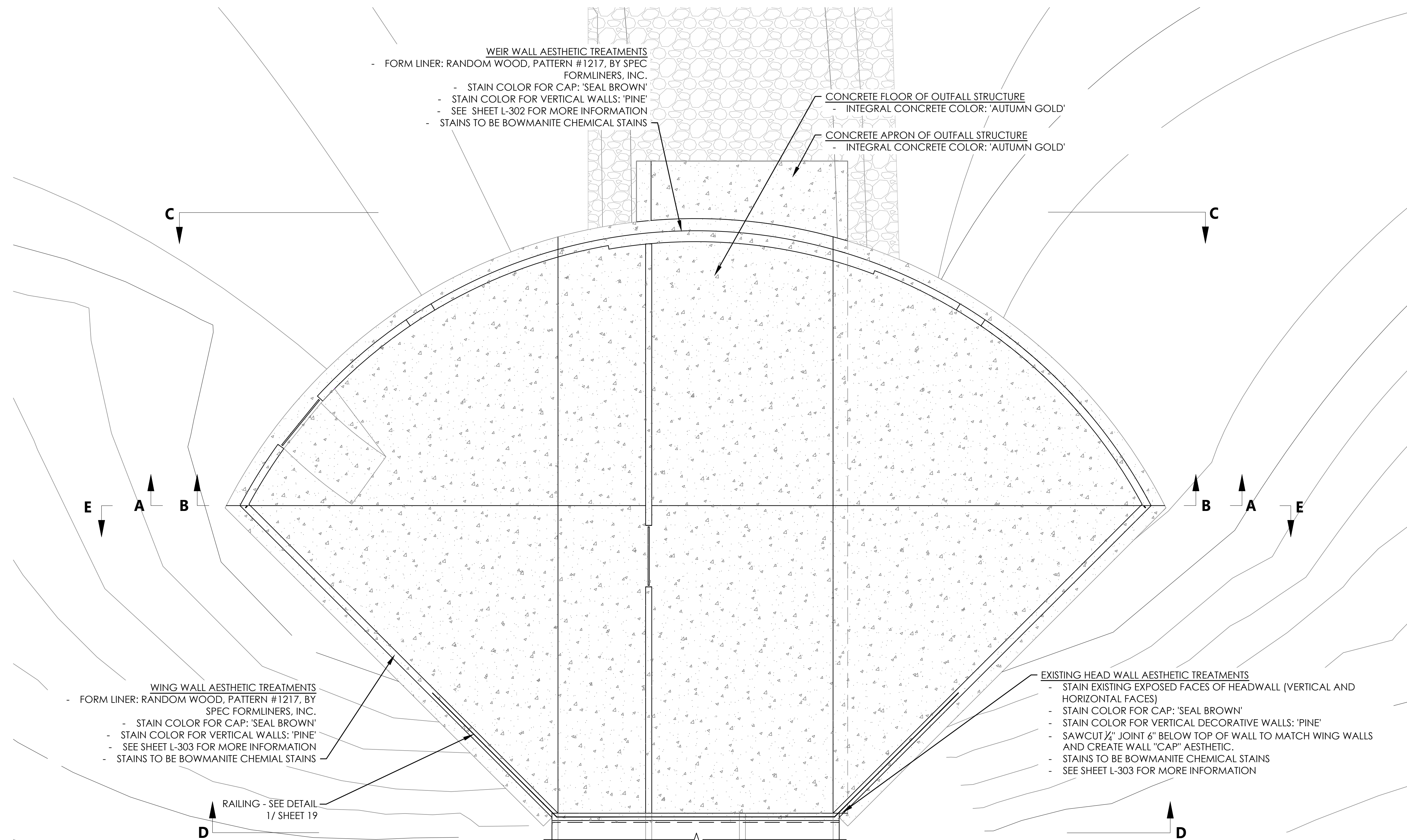

- NOTES:
- SEE STRUCTURAL SHEETS FOR STRUCTURE LAY OUT, FOOTERS, JOINT LAYOUT, AND DESIGN DETAILS.
 - SEE SHEET L-302 FOR ADDITIONAL AESTHETIC DESIGN DETAILS.
 - FORMLINER TO BE PATTERN #1217 'RANDOM WOOD' - BY SPEC FORMLINER (714) 429-9500.
 - FORMLINER TO BE PLACED WITH RIBS RUNNING HORIZONTALLY.

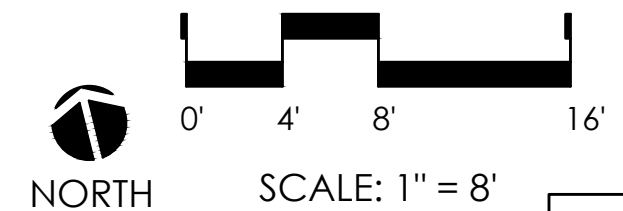

1 OUTFALL STRUCTURE AESTHETIC PLAN
L-301 PLAN

SCALE: 1/8" = 1'-0"



REV	REVISION DESCRIPTION	DATE	CHND	CHKD	APPR



CITY OF COLORADO SPRINGS
 30 S. NEVADA AVE., SUITE 401
 COLORADO SPRINGS, CO 80903
 (719) 385-5980

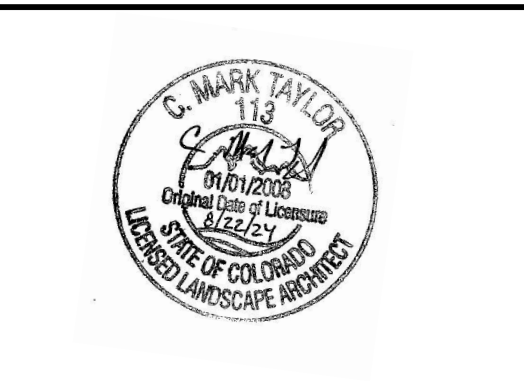

SAND CREEK DETENTION POND NO. 2
OUTFALL STRUCTURE AESTHETIC DETAILS

JOB NUMBER	65420975
DATE	AUGUST 2024
DRAWING	L-301
29	of 51

THIS AND ANY OTHER TECHNICAL DRAWING OR INSTRUMENT IS AN INSTRUMENT OF SERVICE PROVIDED BY MERRICK AND COMPANY FOR A SPECIFIC PROJECT. IT IS NOT INTENDED TO BE REUSED FOR ANY OTHER PROJECT OR FOR REUSE IN ANY MANNER WITHOUT THE WRITTEN CONSENT OF MERRICK AND COMPANY. SHALL BE AT THE SOLE RISK OF THE USER FOR ANY REUSE OF THIS DRAWING FOR ANY OTHER PROJECT.

File Location: \\projects\12105-Sand Creek Pond #2 Drawings - Technical\Construction Drawings\2106 - Sand Creek Pond #2 Architectural Details.dwg Plot Date: 8/22/2024 4:53 PM Last Saved By: MT-ALERICO

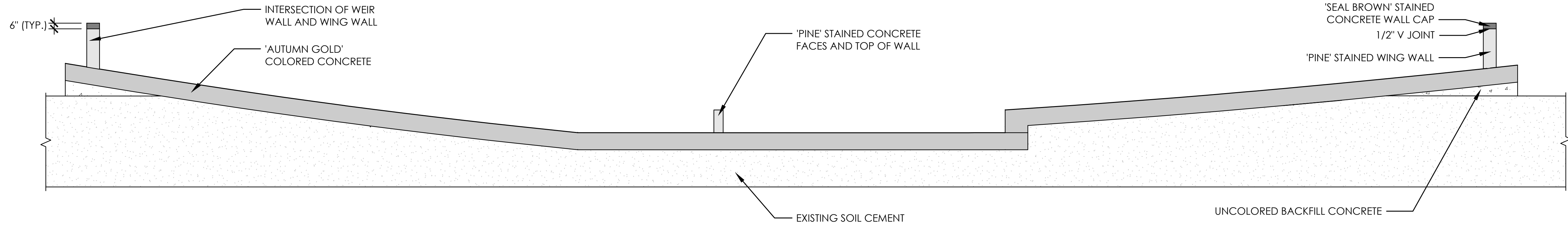

1 OUTFALL STRUCTURE - SECTION A-A
L-302 SECTION

SCALE: 3/16" = 1'-0"

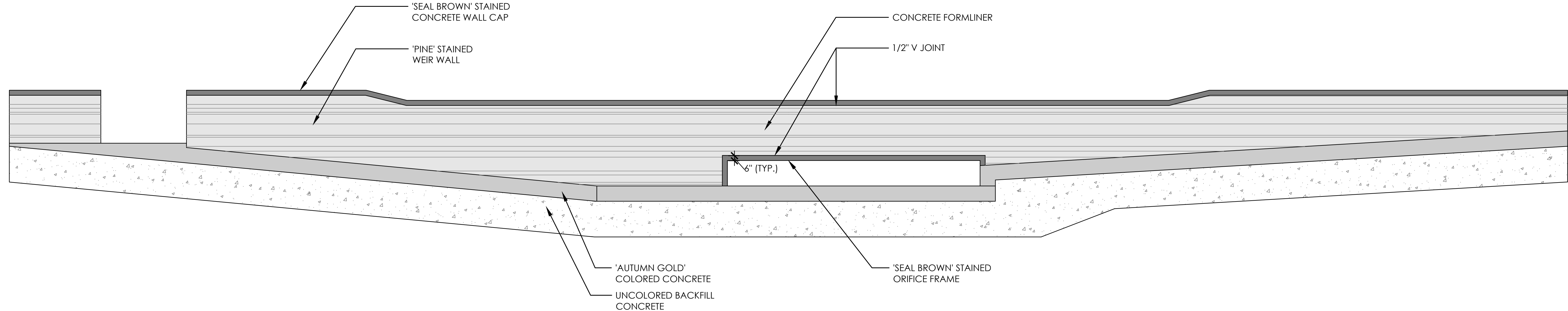

2 OUTFALL STRUCTURE WEIR WALL - SECTION / ELEVATION B-B
L-302 SECTION / ELEVATION

SCALE: 3/16" = 1'-0"

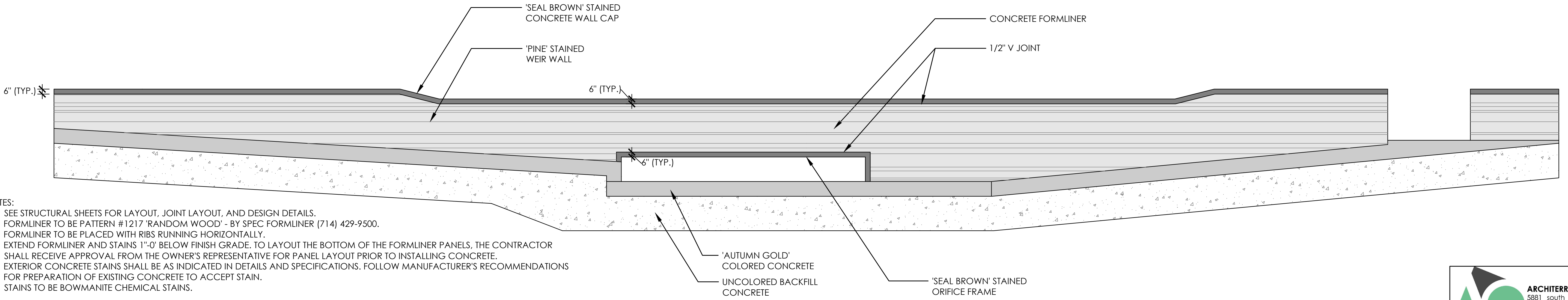

3 OUTFALL STRUCTURE WEIR WALL - SECTION / ELEVATION C-C
L-302 SECTION / ELEVATION

SCALE: 3/16" = 1'-0"

- NOTES:
- SEE STRUCTURAL SHEETS FOR LAYOUT, JOINT LAYOUT, AND DESIGN DETAILS.
 - FORMLINER TO BE PATTERN #1217 'RANDOM WOOD' - BY SPEC FORMLINER (714) 429-9500.
 - FORMLINER TO BE PLACED WITH RIBS RUNNING HORIZONTALLY.
 - EXTEND FORMLINER AND STAINS 1"-0" BELOW FINISH GRADE. TO LAYOUT THE BOTTOM OF THE FORMLINER PANELS, THE CONTRACTOR SHALL RECEIVE APPROVAL FROM THE OWNER'S REPRESENTATIVE FOR PANEL LAYOUT PRIOR TO INSTALLING CONCRETE.
 - EXTERIOR CONCRETE STAINS SHALL BE AS INDICATED IN DETAILS AND SPECIFICATIONS. FOLLOW MANUFACTURER'S RECOMMENDATIONS FOR PREPARATION OF EXISTING CONCRETE TO ACCEPT STAIN.
 - STAINS TO BE BOWMANITE CHEMICAL STAINS.

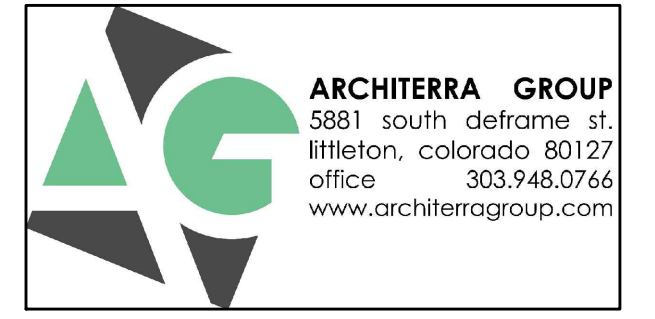

REV	REVISION DESCRIPTION	DATE	CHND	CHKD	APPR



CITY OF COLORADO SPRINGS
30 S. NEVADA AVE., SUITE 401
COLORADO SPRINGS, CO 80903
(719) 385-5980



SAND CREEK DETENTION POND NO. 2
OUTFALL STRUCTURE AESTHETIC DETAILS

JOB NUMBER	65420975
DATE	AUGUST 2024
DRAWING	L-302
30 of 51	180 of 507

THE NEW ORANGE COUNTY WATER TREATMENT PLANT IS AN INSTRUMENT OF SERVICE PROVIDED BY ARCHITERRA GROUP, INC. FOR THE PROJECT. IT IS NOT INTENDED OR REPRESENTED TO BE SUITABLE FOR REUSE IN WHOLE OR IN PART OR FOR EXTENSION OF THE PROJECT OR ON ANY OTHER PROJECT. REUSE OR MODIFICATION OF ANY ILLUSTRATION WITHOUT THE PROPER EXPRESSION OF WRITTEN CONSENT OF ARCHITERRA GROUP, INC. SHALL BE AT THE USER'S RISK. THE USER ASSUMES ALL LIABILITY FOR SUCH REUSE.

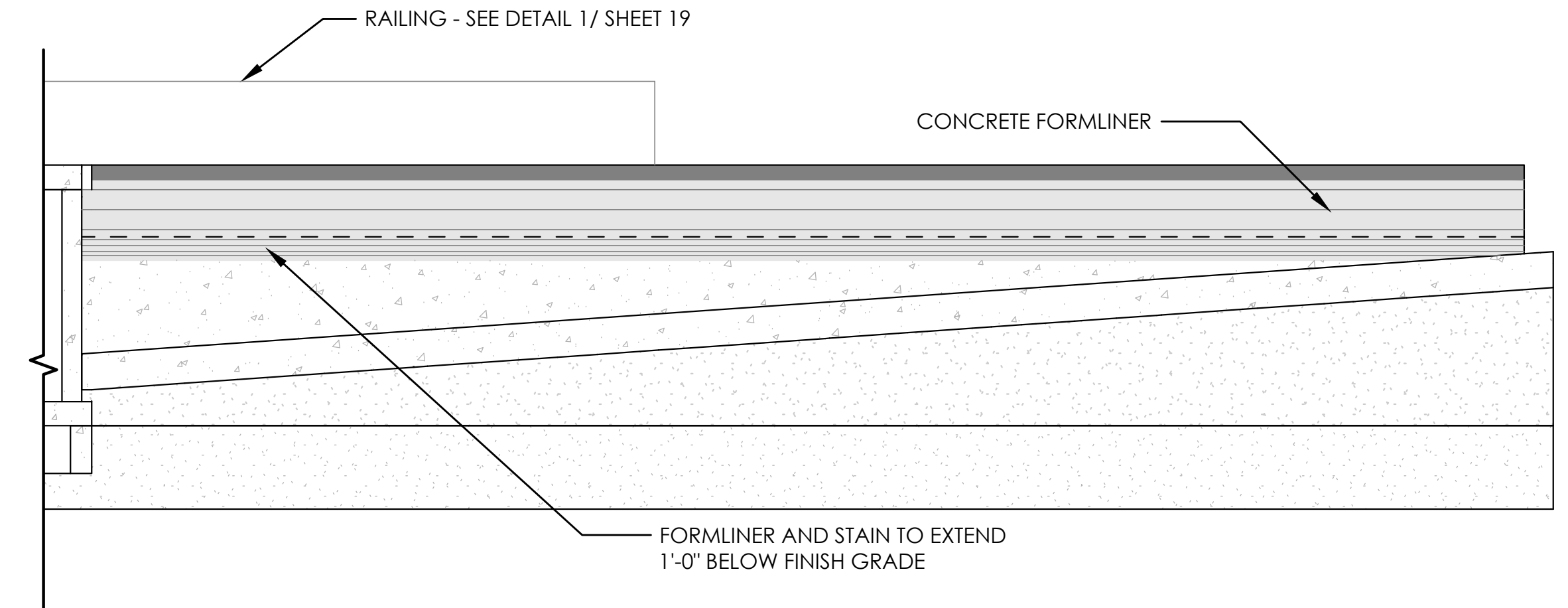
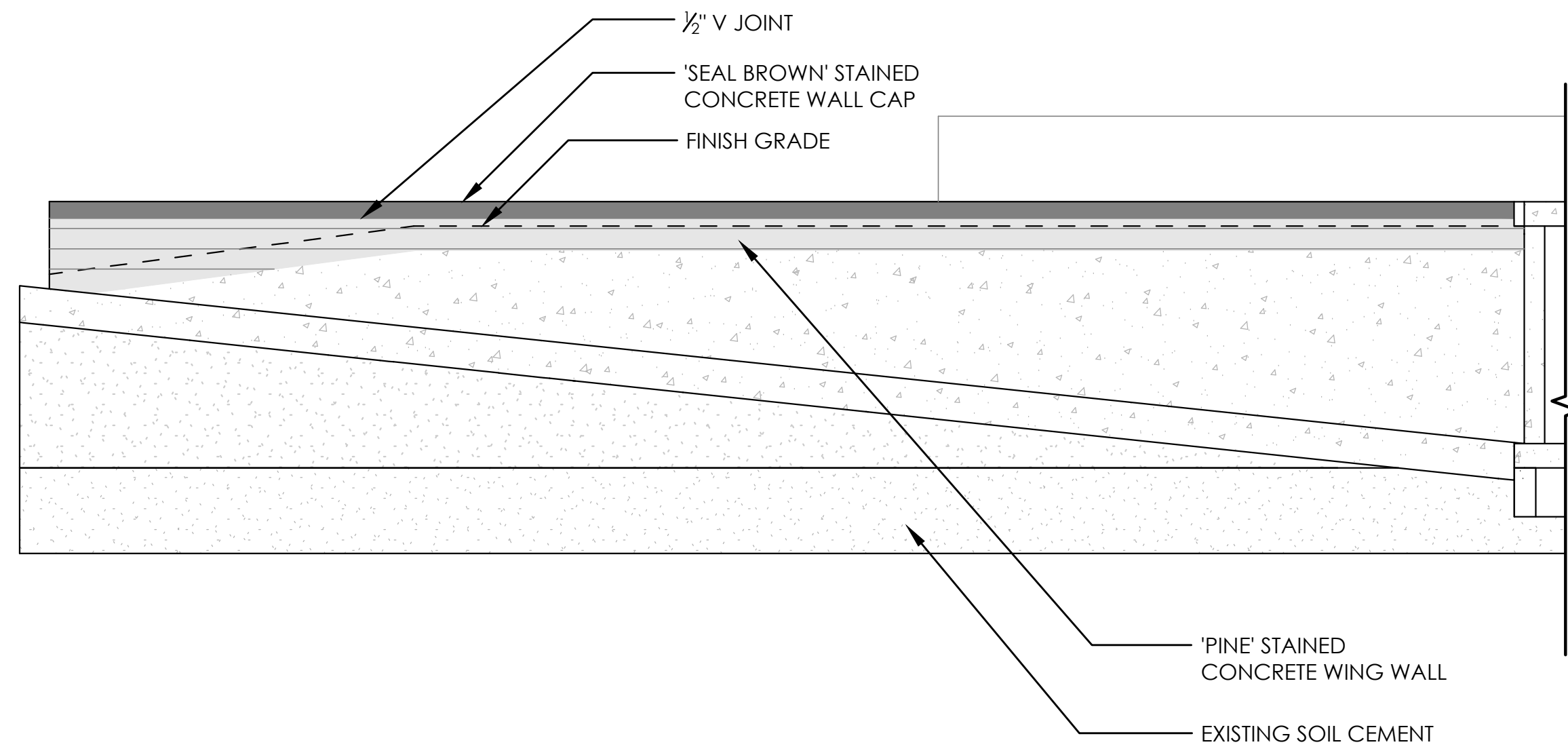

1 OUTFALL STRUCTURE WING WALLS - SECTION / ELEVATION D-D
 L-303 SECTION / ELEVATION

SCALE: 3/16" = 1'-0"

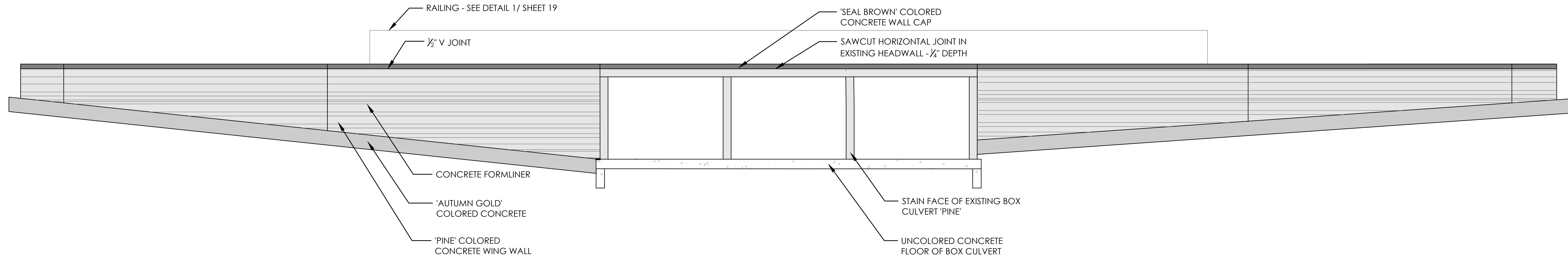

2 OUTFALL STRUCTURE WING WALLS - SECTION / ELEVATION E-E
 L-303 SECTION / ELEVATION

SCALE: 3/16" = 1'-0"

- NOTES:
- SEE STRUCTURAL SHEETS FOR LAYOUT, JOINT LAYOUT, AND DESIGN DETAILS.
 - FORMLINER TO BE PATTERN #1217 'RANDOM WOOD' - BY SPEC FORMLINER (714) 429-9500.
 - FORMLINER TO BE PLACED WITH RIBS RUNNING HORIZONTALLY.
 - EXTEND FORMLINER AND STAINS 1'-0" BELOW FINISH GRADE. TO LAYOUT THE BOTTOM OF THE FORMLINER PANELS, THE CONTRACTOR SHALL RECEIVE APPROVAL FROM THE OWNER'S REPRESENTATIVE FOR PANEL LAYOUT PRIOR TO INSTALLING CONCRETE.
 - EXTERIOR CONCRETE STAINS SHALL BE AS INDICATED IN DETAILS AND SPECIFICATIONS. FOLLOW MANUFACTURER'S RECOMMENDATIONS FOR PREPARATION OF EXISTING CONCRETE TO ACCEPT STAIN.
 - STAINS TO BE BOWMANITE CHEMICAL STAINS.



REV	REVISION DESCRIPTION	DATE	CHND	CHKD	APPR



CITY OF COLORADO SPRINGS
 30 S. NEVADA AVE., SUITE 401
 COLORADO SPRINGS, CO 80903
 (719) 385-5980

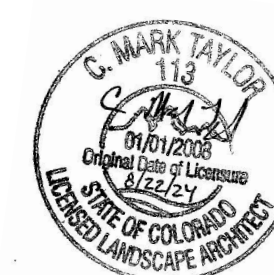

SAND CREEK DETENTION POND NO. 2
 OUTFALL STRUCTURE AESTHETIC DETAILS

JOB NUMBER	65420975
DATE	AUGUST 2024
DRAWING	L-303
31	of 51

THIS AND ALL OTHERS ARE EXISTING. ANY INFORMATION OR SERVICE PROVIDED BY MERRICK AND COMPANY FOR A DESIGN PROJECT IS NOT INTENDED OR REPRESENTED TO BE SUITABLE FOR REUSE IN WHOLE OR IN PART FOR ANY OTHER PROJECT OR ANY OTHER PURPOSE. REUSE OR MODIFICATION OF ANY INFORMATION OR SERVICE WITHOUT THE WRITTEN CONSENT OF MERRICK AND COMPANY SHALL BE AT THE USER'S RISK. THE USER ASSUMES ALL LIABILITY FOR SUCH REUSE.

File Location: C:\projects\12105-Sand Creek Pond #2 Drawings - Technical\Construction Drawings\2106 - Sand Creek Pond #2 Architectural Details.dwg Plot Date: 8/22/2024 4:55 PM Last Saved By: M.T. ALERICO

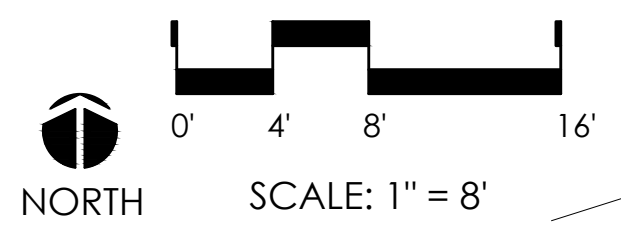
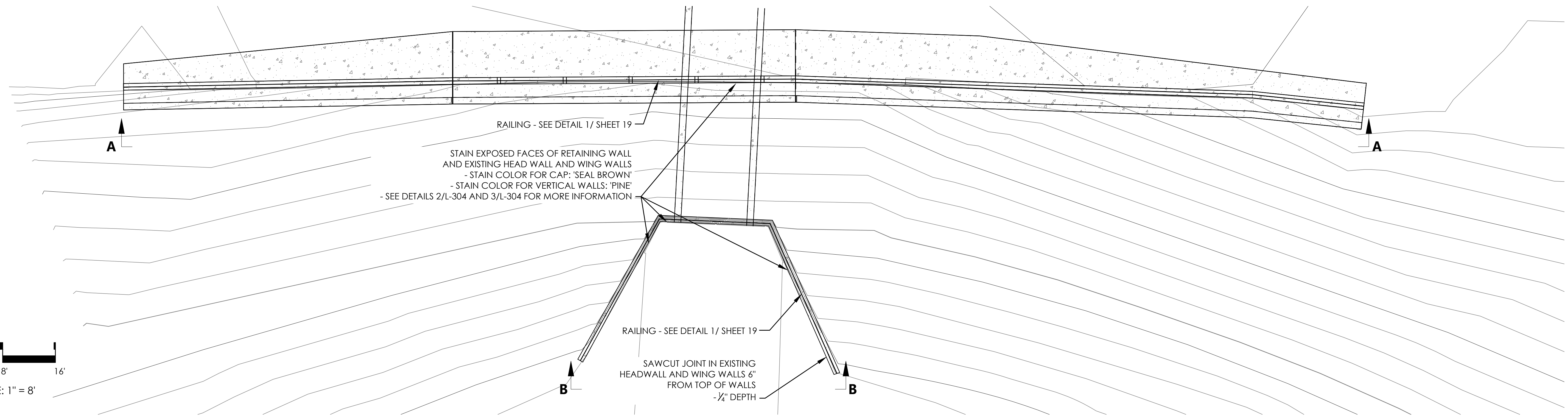

1 TUTT OUTFALL STRUCTURE AESTHETIC PLAN
 L-304 PLAN

SCALE: 1/8" = 1'-0"

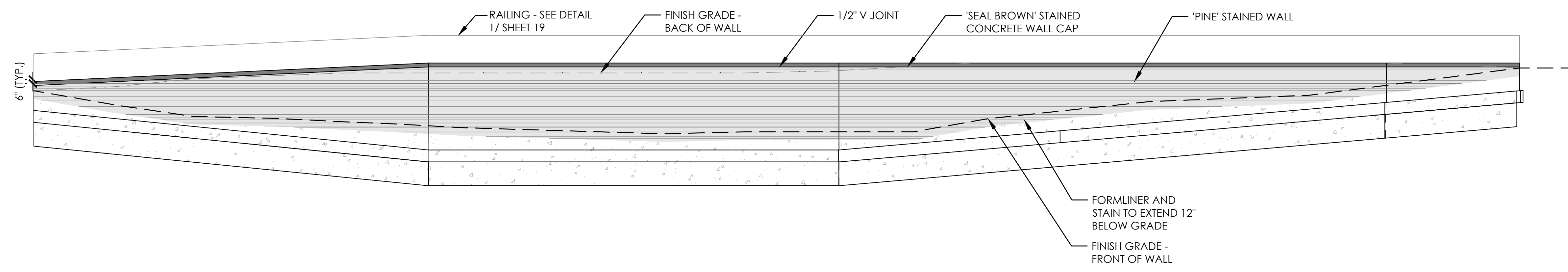

2 TUTT RETAINING WALL - SECTION / ELEVATION A-A
 L-304 SECTION / ELEVATION

SCALE: 1/8" = 1'-0"

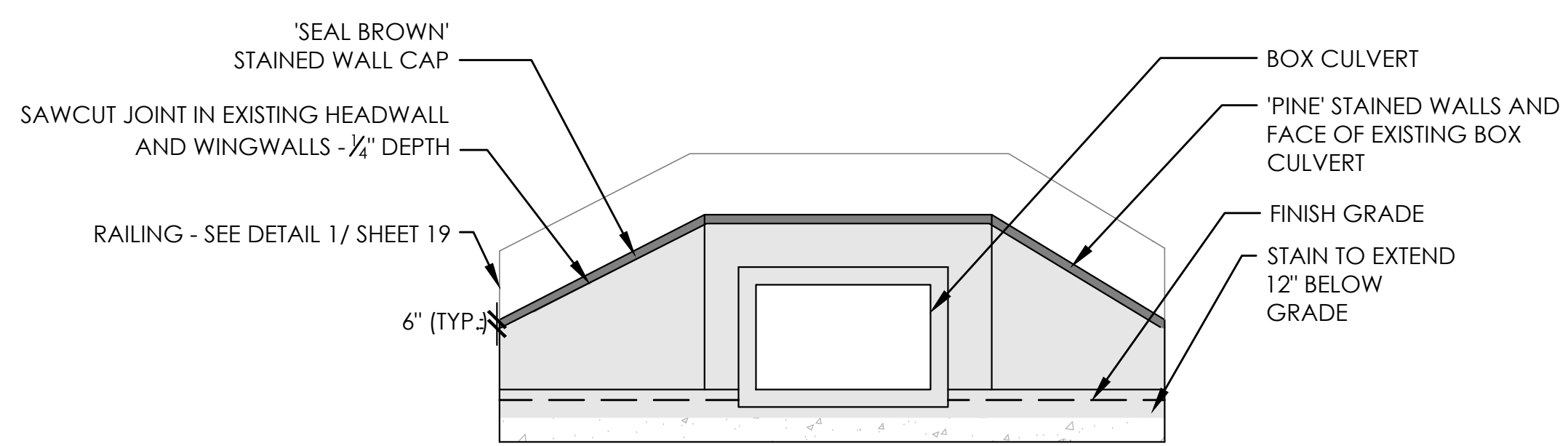

3 TUTT OUTFALL STRUCTURE - SECTION / ELEVATION B-B
 L-304 SECTION / ELEVATION

SCALE: 1/8" = 1'-0"

- NOTES:
1. SEE STRUCTURAL SHEETS FOR LAYOUT, JOINT LAYOUT, AND DESIGN DETAILS.
 2. FORMLINER TO BE PATTERN #1217 'RANDOM WOOD' - BY SPEC FORMLINER (714) 429-9500.
 3. FORMLINER TO BE PLACED WITH RIBS RUNNING HORIZONTALLY.
 4. EXTEND FORMLINER AND STAINS 1'-0" BELOW FINISH GRADE. TO LAYOUT THE BOTTOM OF THE FORMLINER PANELS, THE CONTRACTOR SHALL RECEIVE APPROVAL FROM THE OWNER'S REPRESENTATIVE FOR PANEL LAYOUT PRIOR TO INSTALLING CONCRETE.
 5. EXTERIOR CONCRETE STAINS SHALL BE AS INDICATED IN DETAILS AND SPECIFICATIONS. FOLLOW MANUFACTURER'S RECOMMENDATIONS FOR PREPARATION OF EXISTING CONCRETE TO ACCEPT STAIN.
 6. STAINS TO BE BOWMANITE CHEMICAL STAINS.



REV	REVISION DESCRIPTION	DATE	CHND	CHKD	APPR



CITY OF COLORADO SPRINGS
 30 S. NEVADA AVE., SUITE 401
 COLORADO SPRINGS, CO 80903
 (719) 385-5980

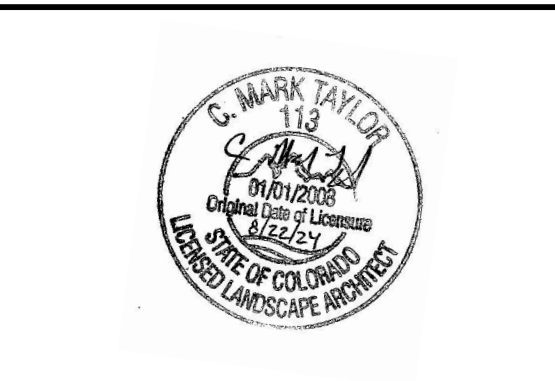

SAND CREEK DETENTION POND NO. 2
 TUTT OUTFALL AND RETAINING WALL
 AESTHETIC DETAILS

JOB NUMBER	65420975
DATE	AUGUST 2024
DRAWING	L-304
32	of 51





STRUCTURAL DRAWING LIST

SHEET No.	DRAWING No.	TITLE
33	S-100	LEGEND, ABBREVIATIONS, AND GENERAL NOTES SHEET 1
34	S-101	LEGEND, ABBREVIATIONS, AND GENERAL NOTES SHEET 2
35	S-102	POND 2 OUTLET ISOMETRIC VIEW
36	S-103	POND 2 OUTLET OUTLINE PLAN
37	S-104	POND 2 OUTLET OUTLINE SECTIONS
38	S-105	POND 2 OUTLET REINFORCEMENT PLAN
39	S-106	POND 2 OUTLET REINFORCEMENT SECTIONS
40	S-107	POND 2 OUTLET REINFORCEMENT SECTIONS
41	S-108	POND 2 OUTLET REINFORCEMENT SECTIONS
42	S-109	POND 2 OUTLET DOWEL ANCHOR PLAN AND DETAILS
43	S-110	POND 2 OUTLET UNDER DRAIN PLAN AND DETAILS
44	S-111	POND 2 OUTLET CONCRETE STANDARD DETAILS
45	S-112	TUTT WALL ISOMETRIC
46	S-113	TUTT WALL OUTLINE PLAN AND ELEVATION
47	S-114	TUTT WALL REINFORCEMENT PLAN AND SECTION
48	S-115	TUTT WALL REINFORCEMENT PLAN AND SECTION
49	S-116	TUTT WALL REINFORCEMENT PLAN AND SECTION
50	S-117	TUTT WALL REINFORCEMENT PLAN AND SECTIONS
51	S-118	POND OUTLET 2 & TUTT RETAINING WALL STEEL HANDRAIL DETAILS

ABBREVIATIONS/LEGEND

NOT ALL ABBREVIATIONS MAY APPLY TO THIS PROJECT

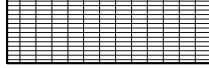
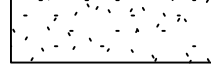
ADDL	ADDITIONAL	GW	GROUND WATER
CL	CENTERLINE	HORIZ	HORIZONTAL
CJ	CONSTRUCTION JOINT	IE	INVERT ELEVATION
CONT JT	CONTRACTION JOINT	IF	INSIDE FACE
CTRL JT	CONTROL JOINT	LLV	LONG LEG VERTICAL
CLR	CLEAR	MAX	MAXIMUM
CMP	CORRUGATED METAL PIPE	MIN	MINIMUM
CONC	CONCRETE	N	NORTH
CONT	CONTINUED/CONTINUOUS	NF	NEAR FACE
DET	DETAIL	OC	ON CENTER
DIA	DIAMETER	OF	OUTSIDE FACE
DWGS	DRAWINGS	OPNG	OPENING
DWLS	DOWELS	OPP	OPPOSITE
EA	EACH	PL	PLATE
EF	EACH FACE	REINF	REINFORCEMENT
EL	ELEVATION	SECT	SECTION
EMB/EMBED	EMBEDDED	SS/SST	STAINLESS STEEL
EQ SP	EQUAL SPACE	STL	STEEL
EW	EACH WAY	T&B	TOP AND BOTTOM
EXIST	EXISTING	THK	THICK
EXP	EXPANSION	TYP	TYPICAL
FF	FAR FACE	UNO	UNLESS NOTED OTHERWISE
GALV	GALVANIZED	VERT	VERTICAL
GR	GRADE	W/	WITH
		WS	WATER SURFACE

	COMPACTED STRUCTURAL FILL		CONCRETE
	GRATING		BACKFILL CONCRETE
	NATIVE FILL		EXISTING SOIL CEMENT

GENERAL NOTES

- ALL MATERIALS, WORKMANSHIP, AND CONSTRUCTION OF PUBLIC IMPROVEMENTS SHALL MEET OR EXCEED THE STANDARDS AND SPECIFICATIONS ADOPTED BY THE CITY OF COLORADO SPRINGS. ALL PUBLIC IMPROVEMENTS SHALL BE INSPECTED AND APPROVED BY THE CITY.
- ALL WORK SHALL CONFORM TO THE INTERNATIONAL BUILDING CODE 2018 EDITION AS AMENDED BY CITY OF COLORADO SPRINGS.
- THE CONTRACTOR IS SPECIFICALLY CAUTIONED THAT THE LOCATION AND/OR ELEVATION OF EXISTING UTILITIES, AS SHOWN ON THESE PLANS, IS BASED UPON RECORDS OF VARIOUS UTILITY COMPANIES AND WHERE POSSIBLE, MEASUREMENTS TAKEN IN THE FIELD. THE INFORMATION IS NOT TO BE RELIED UPON AS BEING EXACT OR COMPLETE. THE SUBSURFACE UTILITY ENGINEERING FOR THE PROJECT IS QUALITY LEVEL D. CALL THE UTILITY NOTIFICATION CENTER OF COLORADO AT 1-800-922-1987 AT LEAST 48 HOURS BEFORE STRIPPING, OR EXCAVATING. PRIOR TO CONSTRUCTION, THE CONTRACTOR SHALL VERIFY PERTINENT LOCATIONS AND ELEVATIONS. IT SHALL BE THE RESPONSIBILITY OF THE CONTRACTOR TO RELOCATE ALL EXISTING UTILITIES THAT CONFLICT WITH THE PROPOSED IMPROVEMENTS SHOWN ON THESE PLANS.
- THE CONTRACTOR SHALL COORDINATE AND COOPERATE WITH THE CITY, AND ALL UTILITY COMPANIES INVOLVED, WITH REGARD TO RELOCATIONS OR ADJUSTMENTS OF EXISTING UTILITIES DURING CONSTRUCTION, AND TO ASSURE THAT THE WORK IS COMPLETED IN A TIMELY FASHION AND WITH A MINIMUM DISRUPTION OR SERVICE. THE CONTRACTOR SHALL BE RESPONSIBLE FOR CONTACTING ALL PARTIES AFFECTED BY ANY DISRUPTION OF UTILITY SERVICE.
- THE CONTRACTOR SHALL OBTAIN ALL NECESSARY PERMITS FROM REGULATORY AUTHORITIES NECESSARY TO PERFORM THE PROPOSED WORK A MINIMUM OF 48 HOURS BEFORE THE START OF CONSTRUCTION. A PERMIT FOR WORK WITHIN THE COLORADO DEPARTMENT OF TRANSPORTATION'S (CDOT'S) RIGHT OF WAY WILL BE REQUIRED. THE CONTRACTOR SHALL APPLY FOR THE PERMIT TO CDOT NO MORE THAN 3 DAYS AFTER GIVEN NOTICE TO PROCEED.
- THE CONTRACTOR IS RESPONSIBLE FOR SURVEYS TO LAYOUT AND CONSTRUCT THE WORK, AND FOR QUANTITY DETERMINATIONS FOR UNIT PRICE ITEMS.
- THE CONTRACTOR SHALL NOT SCALE DRAWINGS FOR CONSTRUCTION PURPOSES. ANY MISSING DIMENSIONS OR DISCREPANCIES IN THE DRAWINGS, SPECIFICATIONS, OR PHYSICAL FEATURES SHALL BE BROUGHT TO THE ATTENTION OF THE ENGINEER FOR RESOLUTION. IF THE CONTRACTOR PROCEEDS PRIOR TO OBTAINING THE ENGINEER'S RESOLUTION, CONTRACTOR DOES SO AT THEIR OWN RISK.
- THE CONTRACTOR SHALL MAINTAIN A SET OF THE CONSTRUCTION DRAWINGS AND SPECIFICATIONS ON SITE AT ALL TIMES. ONE SET OF THE CONSTRUCTION DRAWINGS SHALL BE MAINTAINED SOLELY TO DOCUMENT ANY CHANGES IN THE WORK AS A RESULT OF CHANGE ORDERS OR FIELD CONDITIONS THAT MAY REQUIRE ALTERNATIVE CONSTRUCTION DETAILS. ALL SUCH CHANGES SHALL BE MARKED ON A FULL SIZE RECORD SET OF DRAWINGS IN PERMANENT INK.
- CONSTRUCTION SAFETY IS THE SOLE RESPONSIBILITY OF THE CONTRACTOR. THE ENGINEER IS NOT RESPONSIBLE FOR SAFETY IN, ON, OR ABOUT THE PROJECT SITE, NOR FOR COMPLIANCE BY THE APPROPRIATE PARTY WITH ANY REGULATIONS RELATING THERETO.
- EXCAVATIONS SHALL BE SHORED AS REQUIRED TO PREVENT SUBSIDENCE OR DAMAGE TO ADJACENT EXISTING STRUCTURES, STREETS, UTILITIES, ETC.
- CONSTRUCTION SHORING AND BRACING OF FORMWORK SHALL BE IN ACCORDANCE WITH ACI 301 "SPECIFICATIONS FOR STRUCTURAL CONCRETE FOR BUILDINGS" AND ACI 347 "RECOMMENDED PRACTICE FOR CONCRETE FORMWORK".
- THE STRUCTURES SHOWN ON THE DRAWINGS HAVE BEEN DESIGNED FOR STABILITY UNDER FINAL CONDITIONS ONLY. THESE PLANS DO NOT INCLUDE THE NECESSARY COMPONENTS OR EQUIPMENT FOR THE STRUCTURES DURING CONSTRUCTION. THE CONTRACTOR IS RESPONSIBLE FOR ALL WORK RELATING TO CONSTRUCTION ERECTION METHODS, BRACING, SHORING, RIGGING, GUYS, SCAFFOLDING, FORMWORK, AND OTHER WORK AIDS REQUIRED TO SAFELY PERFORM THE WORK SHOWN.
- HEAVY COMPACTION EQUIPMENT SHALL NOT BE USED WITHIN 5'-0" OF WALLS. USE HAND GUIDED COMPACTION EQUIPMENT FOR THESE AREAS.
- OBSERVATIONS OF THE WORK IN PROGRESS AND ON-SITE VISITS BY THE ENGINEER OR OWNER ARE NOT TO BE CONSTRUED AS ACCEPTANCE OR WARRANTIES OF THE CONTRACTOR'S CONTRACTUAL OBLIGATIONS.
- CONTRACTOR SHALL SUBMIT SHOP DRAWINGS FOR CONCRETE MIXTURE DESIGN, CONCRETE REINFORCEMENT, HANDRAIL, AND STRUCTURAL AND MISCELLANEOUS STEEL PRIOR TO FABRICATION FOR ENGINEER REVIEW.
- SPECIAL INSPECTION (OWNER FURNISHED) IS REQUIRED IN ACCORDANCE WITH IBC CHAPTER 17 INCLUDING THE FOLLOWING PORTIONS OF THE WORK:
 - CONCRETE
 - REINFORCING STEEL
 - CAST-IN-PLACE ANCHOR BOLTS AND EMBEDS
- ALL FOUNDATION SURFACES SHALL BE INSPECTED BY THE GEOTECHNICAL ENGINEER PRIOR TO PLACEMENT OF GRANULAR FILL AND REINFORCING STEEL. NOTIFY ENGINEER AT LEAST TWO DAYS IN ADVANCE.
- NOTIFY THE ENGINEER AT LEAST 48 HOURS IN ADVANCE OF ANY CONCRETE PLACEMENTS.
- CONCRETE TESTS FOR CONCRETE DELIVERED TO THE SITE AND SOIL COMPACTION TESTING ARE THE RESPONSIBILITY OF THE CONTRACTOR. THE ENGINEER RESERVES THE RIGHT TO CONDUCT ITS OWN TESTS AS HE MAY DEEM NECESSARY.
- SEE ARCHITECTURAL PLANS FOR AESTHETIC TREATMENT INCLUDING COLORED CONCRETE, FORMLINER, AND CONCRETE FINISHES.
- SEE CIVIL PLANS FOR LOCATION OF ALL STRUCTURES.
- SEE 12/06 KIOWA ENGINEERING CORPORATION DRAWING: SAND CREEK DETENTION BASIN NO. 2, BOX CULVERT DETAILS, SHEET 13A, FOR EXISTING CONDITIONS.

REV	REVISION DESCRIPTION	DATE	CHND	CHKD	APPR



CITY OF COLORADO SPRINGS
30 S. NEVADA AVE., SUITE 401
COLORADO SPRINGS, CO 80903
(719) 385-5980

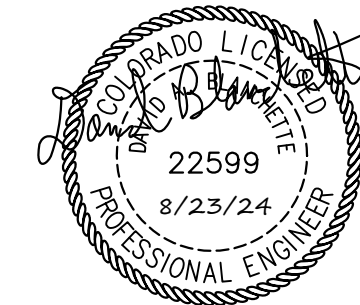

SAND CREEK DETENTION POND NO. 2

POND OUTLET STRUCTURE
LEGEND, ABBREVIATIONS, AND GENERAL NOTES SHEET 1

JOB NUMBER	65420975
DATE	8/23/24
DRAWING NO.	S-100
SHEET	33 of 51



CONCRETE NOTES

- ALL CONCRETE IS DESIGNED IN ACCORDANCE WITH AMERICAN CONCRETE INSTITUTE, ACI 350-20 OR ACI 318-14 AND SHALL BE CONSTRUCTED IN ACCORDANCE WITH PROJECT SPECIFICATIONS.
- CONCRETE SHALL HAVE A MINIMUM 28 DAY COMPRESSIVE STRENGTH OF 4500 PSI UNLESS NOTED OTHERWISE.
- CONCRETE WORK SHALL CONFORM TO ACI 301.
- REINFORCEMENT STEEL SHALL BE DEFORMED BARS CONFORMING IN QUALITY TO THE REQUIREMENTS OF ASTM A-615, "SPECIFICATIONS FOR DEFORMED AND PLAIN CARBON STEEL BARS FOR CONCRETE REINFORCEMENT", GRADE 60.
- ALL DETAILING, FABRICATION AND PLACING OF REINFORCING BARS, UNLESS OTHERWISE INDICATED, SHALL BE IN ACCORDANCE WITH ACI-315, "MANUAL OF STANDARD PRACTICE FOR DETAILING REINFORCED CONCRETE STRUCTURES", LATEST EDITION.
- CONSTRUCTION TOLERANCES SHALL BE IN ACCORDANCE WITH ACI 117.
- METAL CLIPS OR SUPPORTS SHALL NOT BE PLACED IN CONTACT WITH THE FORMS OR THE SUBGRADE. CONCRETE BLOCKS (OR DOBIES) SUPPORTING BARS ON SUBGRADE SHALL BE IN SUFFICIENT NUMBERS TO SUPPORT THE BARS WITHOUT SETTLEMENT, BUT IN NO CASE SHALL SUCH SUPPORT BE CONTINUOUS.
- REINFORCING BARS AND ACCESSORIES SHALL NOT BE IN CONTACT WITH THE PIPE, PIPE FLANGE OR METAL PARTS EMBEDDED IN CONCRETE, A MINIMUM OF 2 INCHES CLEARANCE SHALL BE PROVIDED AT ALL TIMES.
- UNLESS OTHERWISE SHOWN ON THE DRAWINGS CONCRETE COVER FOR REINFORCING BARS SHALL BE AS FOLLOWS:
 - FOR CONCRETE PLACED AGAINST EARTH 3"
 - FOR CONCRETE FORMED BUT EXPOSED TO EARTH, WEATHER, OR FLOWING WATER 2"
- UNLESS OTHERWISE NOTED, WALLS AND SLABS SHOWN WITH A SINGLE LAYER OF REINFORCEMENT SHALL HAVE THAT REINFORCEMENT CENTERED.
- PLACING OF CONCRETE SHALL CONFORM TO ACI 304R. HOT WEATHER CONCRETE SHALL BE PLACED PER ACI 305R. COLD WEATHER CONCRETE SHALL BE PLACED PER ACI 306R.
- ALL DIMENSIONS TO A JOINT ARE TO THE CENTERLINE OF THE JOINT.
- DIMENSIONS NOT SHOWN ARE THE SAME AS DIMENSIONS FOR IDENTICAL DETAILS SHOWN ELSEWHERE.
- BEFORE PLACING CONCRETE ON GRADE, CARE SHALL BE TAKEN THAT ALL BURIED MATERIAL BELOW GRADE IS IN PLACE.
- PIPE SLEEVES AND EMBEDDED PIPING 12" IN DIAMETER AND LARGER ARE ALWAYS SHOWN ON THE CONCRETE OUTLINE DRAWINGS. SMALLER DIAMETER PIPE SLEEVES OR PIPING MAY OR MAY NOT BE SHOWN ON THE CONCRETE OUTLINE DRAWINGS.
- CHAMFER EDGES OF PERMANENTLY EXPOSED CONCRETE SURFACES WITH A 45 DEGREE BEVEL, 3/4"x3/4".
- DRAWINGS ARE NOT TO BE SCALED FOR ESTIMATING OR ANY OTHER PURPOSE.
- ALL REINFORCEMENT BENDS AND LAPS, UNLESS OTHERWISE NOTED, SHALL SATISFY THE FOLLOWING MINIMUM REQUIREMENT:

DETAIL OF REINFORCEMENT - LAP LENGTHS

BAR SIZE	#4	#5	#6	#7	#8	#9	#10	#11	
CONCRETE DESIGN STRENGTH	4500 PSI								
GR 60	TOP BAR OTHER BAR	2'-6" 1'-11"	3'-2" 2'-5"	3'-9" 2'-11"	5'-6" 4'-3"	6'-4" 4'-10"	7'-1" 5'-6"	8'-0" 6'-2"	8'-11" 6'-10"

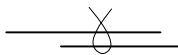
* TOP BARS SHALL BE DEFINED AS ANY HORIZONTAL BARS PLACED SUCH THAT MORE THAN 12" FRESH CONCRETE IS CAST IN THE MEMBER BELOW THE BAR, IN ANY SINGLE PLACEMENT. HORIZONTAL WALL BARS ARE CONSIDERED TOP BARS.

- SPLICES ARE TO BE MADE SO THAT THE GIVEN DISTANCES TO FACE OF CONCRETE WILL BE MAINTAINED.
- DIMENSIONS ARE TO THE CENTERLINES OF THE BARS UNLESS SHOWN OTHERWISE.
- REINFORCEMENT PARALLELING CONSTRUCTION JOINTS SHALL HAVE A MINIMUM OF 2" CLEAR COVER.
- REINFORCEMENT AT SMALL OPENINGS (MAX 1'-6") IN WALLS AND SLABS MAY BE SPREAD APART NOT MORE THAN 1 1/2 TIMES THE BAR SPACING.
- REINFORCEMENT MAY BE ADJUSTED Laterally TO MAINTAIN A CLEAR DISTANCE OF AT LEAST 1" BETWEEN THE REINFORCEMENT AND WATERSTOPS, ANCHOR BOLTS, FORM TIES, CONDUITS, AND OTHER EMBEDDED MATERIAL. IN HEAVILY REINFORCED AREAS RELOCATION OF THE EMBEDDED MATERIAL MUST BE CONSIDERED.
- IN NO CASE SHOULD BARS BE FIELD BENT TO GREATER THAN 6 TO 1 SLOPE.
- BARS SHOWN WITH BENDS NOT DIMENSIONED SHALL BE ASSUMED TO END WITH A STANDARD HOOK.
- THE  SYMBOL DESIGNATES THE BAR CALLOUTS ARE THE SAME SIZE AND SPACING.
- REINFORCEMENT PARALLEL TO ANCHOR BOLTS OR OTHER EMBEDDED MATERIAL SHALL BE PLACED TO MAINTAIN A CLEAR DISTANCE OF AT LEAST 1-1/3 TIMES THE MAXIMUM SIZE AGGREGATE.
- THE FIRST AND LAST BARS IN WALLS AND SLABS, STIRRUPS IN BEAMS, AND TIES IN COLUMNS ARE TO START AND END AT A MAXIMUM OF ONE HALF OF THE ADJACENT BAR SPACING.
- BARS SHOWN THUS  #8@12, INDICATE A GROUP OF THE SAME SIZE BARS EQUALLY SPACED.
- BACKFILL CONCRETE SHALL HAVE A MINIMUM 28 DAY COMPRESSIVE STRENGTH OF 2500 PSI.

STRUCTURAL STEEL NOTES

- ALL STRUCTURAL AND MISCELLANEOUS STEEL SHALL BE DESIGNED, FABRICATED AND ERECTED IN ACCORDANCE WITH THE LATEST CODES AND SPECIFICATIONS OF THE AMERICAN INSTITUTE OF STEEL CONSTRUCTION (AISC) AND IN ACCORDANCE WITH THESE DRAWINGS.
- ALL BARS, PLATES, AND ANGLE SHAPES SHALL BE OF STEEL MEETING ASTM A36 SPECIFICATIONS UNLESS NOTED OTHERWISE. W STRUCTURAL SHAPES SHALL CONFORM TO ASTM A992.
- ALL WELDS SHALL BE PERFORMED BY AWS CERTIFIED WELDERS AND SHALL CONFORM TO AWS D1.1 LATEST EDITION. ALL BUTT WELDS ARE FULL PENETRATION UNLESS INDICATED OTHERWISE. WELD FILLER METAL SHALL BE AWS A5.1 OR A5.5 E70 XX SERIES ELECTRODES.
- ALL WELDS FOUND DEFECTIVE SHALL BE REPAIRED AND/OR REPLACED AND RETESTED FOR ADEQUACY AT THE CONTRACTOR'S EXPENSE.
- AT ALL FIELD WELDS AT EMBED PLATES AND ANGLES, LOW HEAT AND INTERMITTENT WELDS SHALL BE UTILIZED TO AVOID SPALLING OR CRACKING THE EXISTING CONCRETE.
- ALL MATERIAL SHALL BE FABRICATED STRAIGHT AND TRUE AND FREE FROM ALL TWISTS AND WARPS.
- HANDRAIL SHALL BE ASTM A500 GRADE B.
- ANCHOR BOLTS SHALL BE SS AND SHALL CONFORM TO ASTM A240 TYPE 316 SS.
- ALL EXPOSED STEEL SHALL BE ELECTROSTATIC COATED.
- BOLTS INDICATED AS ANCHOR BOLTS SHALL CONFORM TO ASTM A307 FOR CARBON STEEL, A193 FOR STAINLESS STEEL, AND A307 WITH A153 ZINC COATING FOR GALVANIZED STEEL EXCEPT WHERE SPECIFICALLY INDICATED OTHERWISE. ALL JOINT CONTACT SURFACES SHALL BE CLEAN AND FREE FROM OIL, DIRT AND PAINT.
- CONNECTIONS NOT DETAILED SHALL BE BY THE CONTRACTOR IN ACCORDANCE WITH THE SPECIFICATION OR AS DIRECTED BY THE ENGINEER.

DESIGN CRITERIA

- APPLICABLE CODES AND STANDARDS
 2021 INTERNATIONAL BUILDING CODE WITH LOCAL BUILDING CODE AMENDMENTS.
 ACI 318-14 AND ACI 350-20
- LOADS
 WIND LOADS
 $V_{ult} \dots \dots \dots$ 130 MPH
 EXPOSURE CATEGORY $\dots \dots \dots$ C
 IMPORTANCE FACTOR $\dots \dots \dots$ I_w = 1.0
 SEISMIC LOADS
 IMPORTANCE FACTOR $\dots \dots \dots$ I_E = 1.0
 SITE CLASS $\dots \dots \dots$ D
 SPECTRAL RESPONSE COEFFICIENTS $\dots \dots \dots$ S_{D5} = 0.185 g
 $\dots \dots \dots$ S_{D1} = 0.059 g
 SEISMIC DESIGN CATEGORY $\dots \dots \dots$ A
- GEOTECHNICAL
 NET ALLOWABLE BEARING PRESSURE FOOTINGS $\dots \dots \dots$ 3000 PSF
 FOUNDATION RECOMMENDATIONS ARE FROM THE REPORT " GEOTECHNICAL EVALUATION REPORT BY VIVID ENGINEERING GROUP, PROPOSED SAND CREEK POND NO. 2 IMPROVEMENTS, VICINITY OF BARNES ROAD AND TUTT BOULEVARD, COLORADO SPRINGS, CO, VIVID PROJECT NO. D21-2-389, REVISION 1."
 DESIGN LOADS:
 VERTICAL EARTH LOAD = 130 LBS/FT³
 ACTIVE EARTH PRESSURE = 83 LBS/FT³
 AT-REST EARTH PRESSURE = 94 LBS/FT³
 PASSIVE STRUCTURAL FILL = 188 LBS/FT³
 PASSIVE WEATHERED BEDROCK = 400 LBS/FT³
 PASSIVE FORMATIONAL BEDROCK = 500 LBS/FT³
 FROST DEPTH = 2'-6"

INSPECTION NOTES

SPECIAL INSPECTIONS SHALL BE CARRIED OUT PER ALL THE REQUIREMENTS IN CHAPTER 17 OF THE 2021 INTERNATIONAL BUILDING CODE. THE OWNER IS RESPONSIBLE FOR RETAINING AN INDEPENDENT INSPECTION AGENCY TO CONDUCT THESE INSPECTIONS. ALL SPECIAL INSPECTORS MUST SUBMIT FINAL REPORTS. THE CONTRACTOR IS RESPONSIBLE FOR PROVIDING THE SPECIAL INSPECTION AGENCY WITH AN UPDATED SCHEDULE SO A PROPER COORDINATION OF WORK CAN OCCUR. SEE IBC CHAPTER 17 FOR ADDITIONAL INFORMATION ON THE FOLLOWING REQUIREMENTS.

- FOUNDATIONS
 A. VISUAL EXAMINATION AND APPROVAL OF ALL FOUNDATION EXCAVATIONS AND MATERIALS BELOW SHALLOW FOUNDATIONS.
 B. VISUAL EXAMINATION AND TESTING OF ALL COMPACTED FILL MATERIALS.
- CONCRETE
 A. TEST CYLINDERS FOR CONCRETE OVER 2,500 PSI.
- REINFORCING
 A. MILL REPORTS AND IDENTIFICATION OF REINFORCING
 B. PLACEMENT OF REINFORCING
 C. CAST IN PLACE CONCRETE ANCHORS
 D. POST INSTALLED CONCRETE ANCHORS
- WELDING
 A. ALL STRUCTURAL FIELD WELDING
- BOLTING
 A. ALL HIGH STRENGTH STRUCTURAL STEEL BOLTING
- STRUCTURAL STEEL
 A. MILL REPORTS AND IDENTIFICATION OF STEEL
- STRUCTURAL OBSERVATIONS

IN ADDITION TO SPECIAL INSPECTIONS THE STRUCTURAL ENGINEER OF RECORD SHALL BE NOTIFIED SO PERIODIC STRUCTURAL OBSERVATIONS CAN BE CONDUCTED FOR THE FOLLOWING ELEMENTS. THIS NOTIFICATION SHALL BE MADE AT LEAST 48 HRS IN ADVANCE OF THE REQUIRED STRUCTURAL OBSERVATION.
 A. REINFORCING STEEL
 B. STRUCTURAL STEEL

DRAINAGE PIPE

- DRAINAGE PIPE SHALL BE 4" DIAMETER PVC SCHEDULE 40 PLASTIC PIPE.
- DRAINAGE PIPE SHALL BE INSTALLED WITH INTERGRAL BELL AND SPIGOT JOINTS. PROVISIONS SHALL BE MADE FOR CONTRACTION AND EXPANSION AT EACH JOINT WITH A RUBBER RING.
- 4 INCH SLOTTED PIPE SHALL HAVE OPEN SLOTS 0.125" WIDE, THAT ARE 1.25" LONG IN 4 ROWS SPREAD EVENLY AROUND THE PIPE CIRCUMFERENCE. SPACING OF ROWS SHALL BE 2" O.C. SLOTS SHALL BE SHOP CUT.
- DRAIN GRAVEL SHALL CONFORM TO ASTM C33 QUALITY AND HAVE A No. 57 GRADATION.

REV	REVISION DESCRIPTION	DATE	CHND	CHKD	APPR

**CITY OF COLORADO SPRINGS
 30 S. NEVADA AVE., SUITE 401
 COLORADO SPRINGS, CO 80903
 (719) 385-5980**

SAND CREEK DETENTION POND NO. 2

POND OUTLET STRUCTURE
 LEGEND, ABBREVIATIONS, AND GENERAL NOTES SHEET 2

JOB NUMBER	65420975
DATE	8/23/24
DRAWING NO.	S-101
SHEET	34 of 51

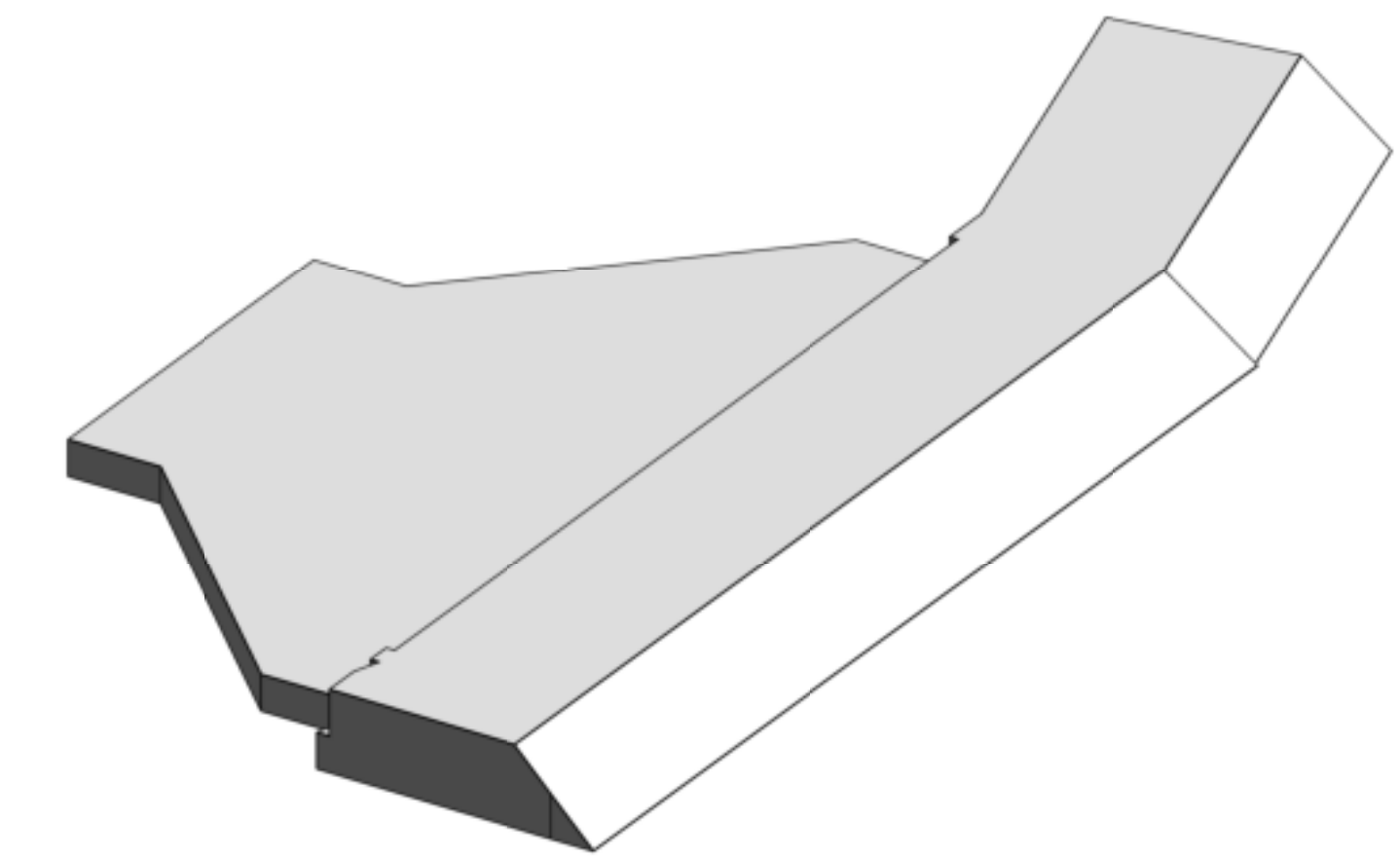
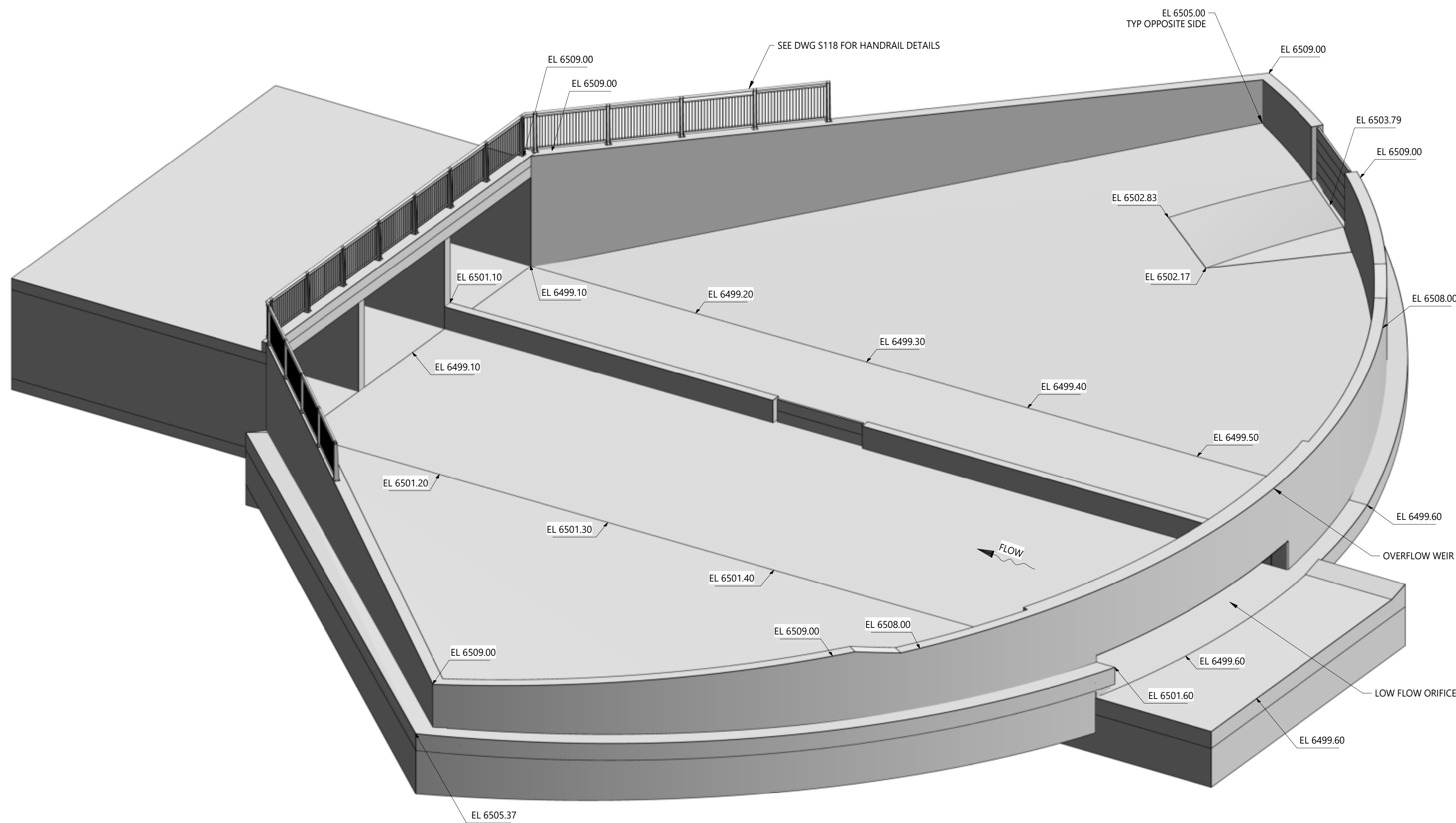

EXISTING SOIL CEMENT
ISOMETRIC

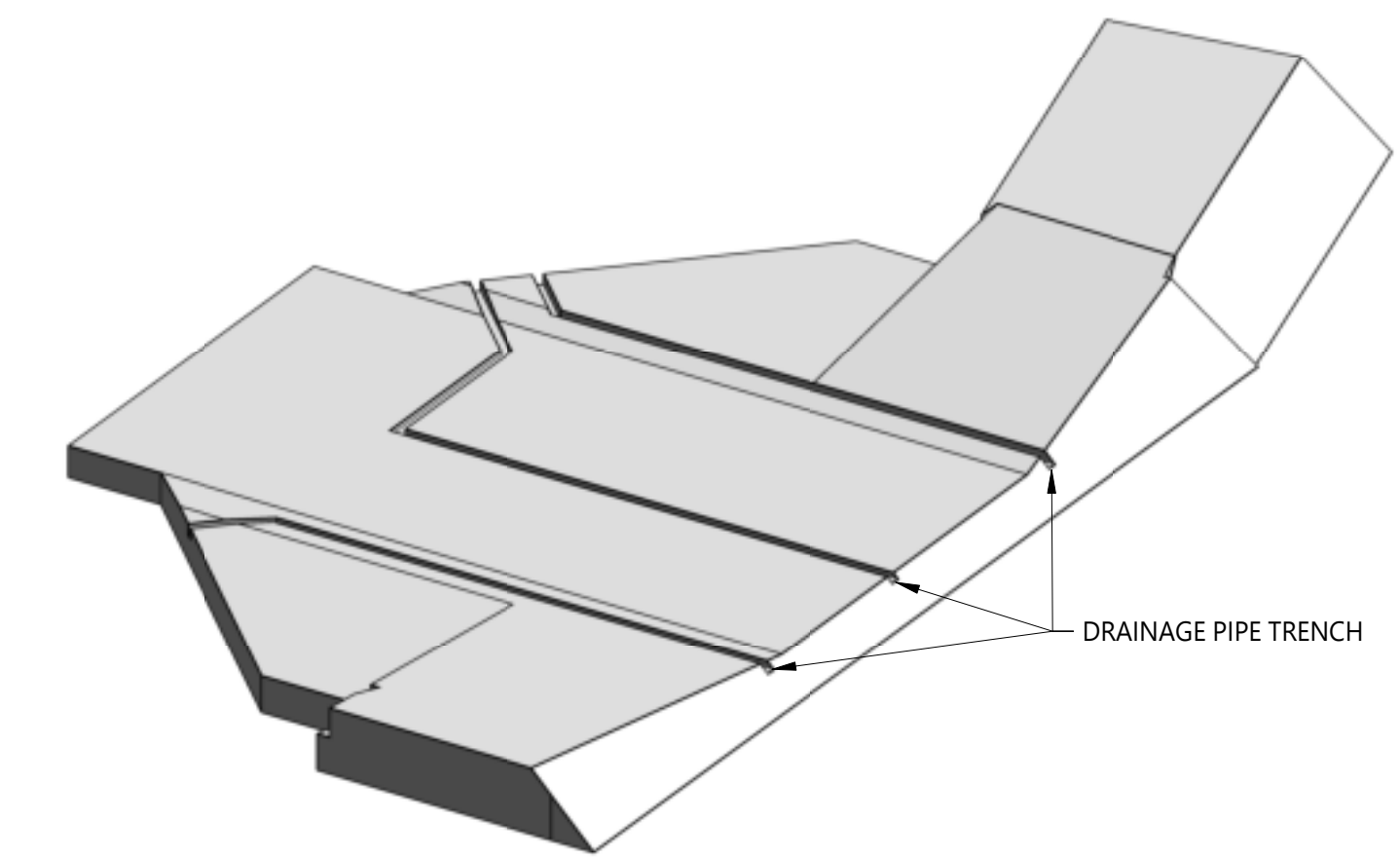

SOIL CEMENT AFTER DEMOLITION
ISOMETRIC

NOTES:

- SEE DRAWING S-100 AND S-101 FOR LEGEND, ABBREVIATIONS, AND GENERAL NOTES.

REV	REVISION DESCRIPTION	DATE	CHND	CHKD	APPR

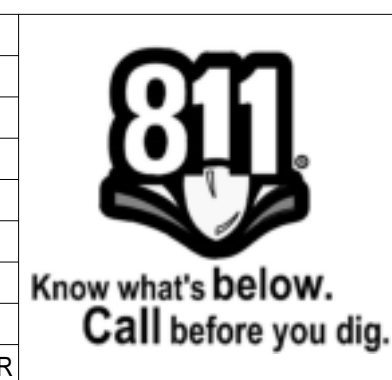

CITY OF COLORADO SPRINGS
30 S. NEVADA AVE., SUITE 401
COLORADO SPRINGS, CO 80903
(719) 385-5980

SM&C
Structural Engineers Inc.
215 S. Wadsworth Blvd., Suite 320
Lakewood, CO 80226 ph 303.274.8656
www.smcstructures.com

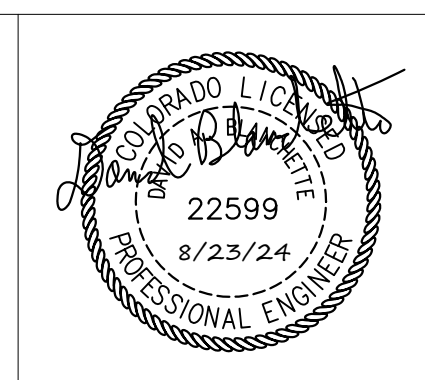

SAND CREEK DETENTION POND NO. 2

POND OUTLET STRUCTURE
ISOMETRIC VIEW

JOB NUMBER	65420975
DATE	8/23/24
DRAWING NO.	S-102
SHEET	35 of 51

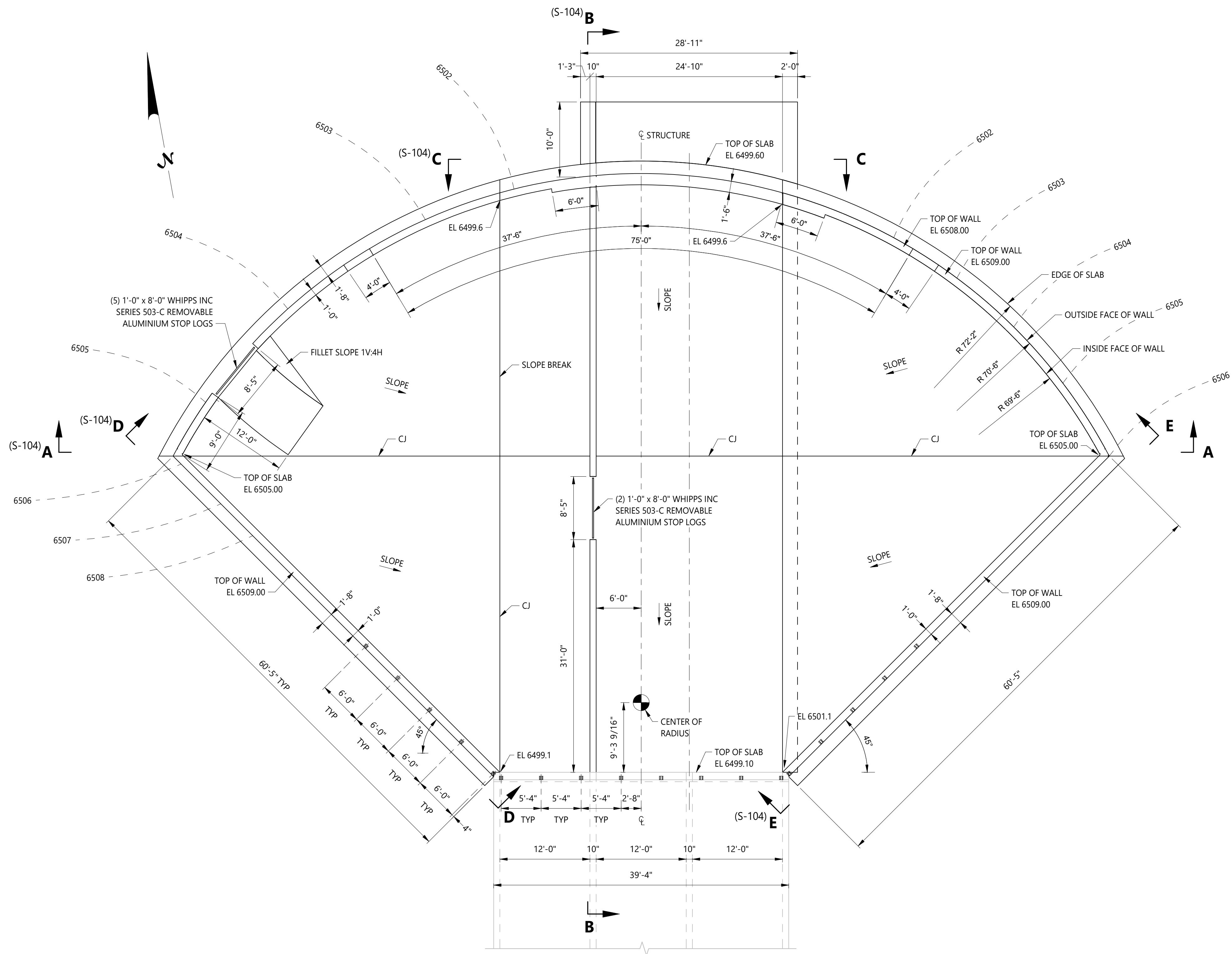

PLAN - POND 2 OUTLET
SCALE: 1/8" = 1'-0"

- NOTES:
- SEE DRAWING S-100 AND S-101 FOR LEGEND, ABBREVIATIONS, AND GENERAL NOTES.
 - DEMO EXISTING WING WALLS, OVERFLOW WALLS, SLAB, AND SOIL CEMENT WITHIN LIMITS OF NEW STRUCTURE.

REV	REVISION DESCRIPTION	DATE	CHND	CHKD	APPR



CITY OF COLORADO SPRINGS
30 S. NEVADA AVE., SUITE 401
COLORADO SPRINGS, CO 80903
(719) 385-5980

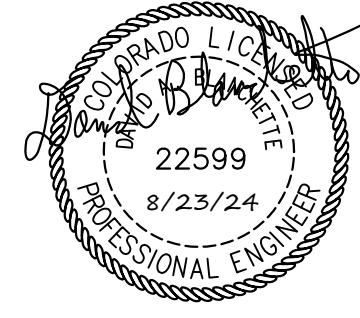

SAND CREEK DETENTION POND NO. 2
POND OUTLET STRUCTURE
OUTLINE PLAN

JOB NUMBER	65420975
DATE	8/23/24
DRAWING NO.	S-103
SHEET	36 of 51

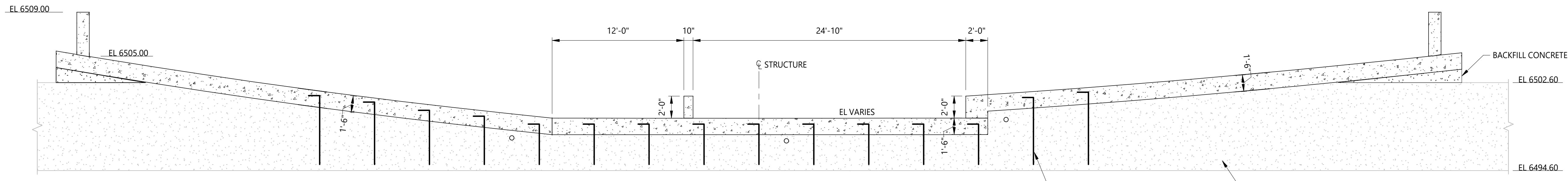

SECTION A - A (S-103)

SCALE: 3/16" = 1'-0"

SEE DWG S-109 FOR LOCATION

EXISTING SOIL CEMENT

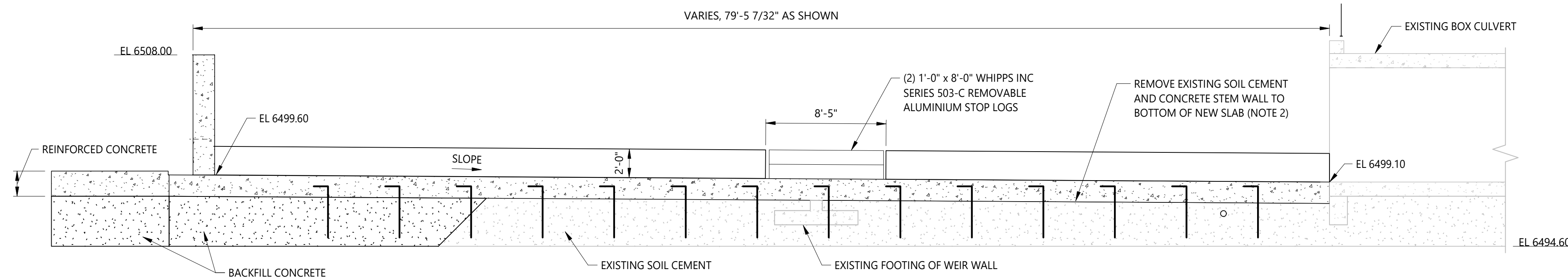

SECTION B - B (S-103)

SCALE: 3/16" = 1'-0"

VARIES, 79'-5 7/32" AS SHOWN

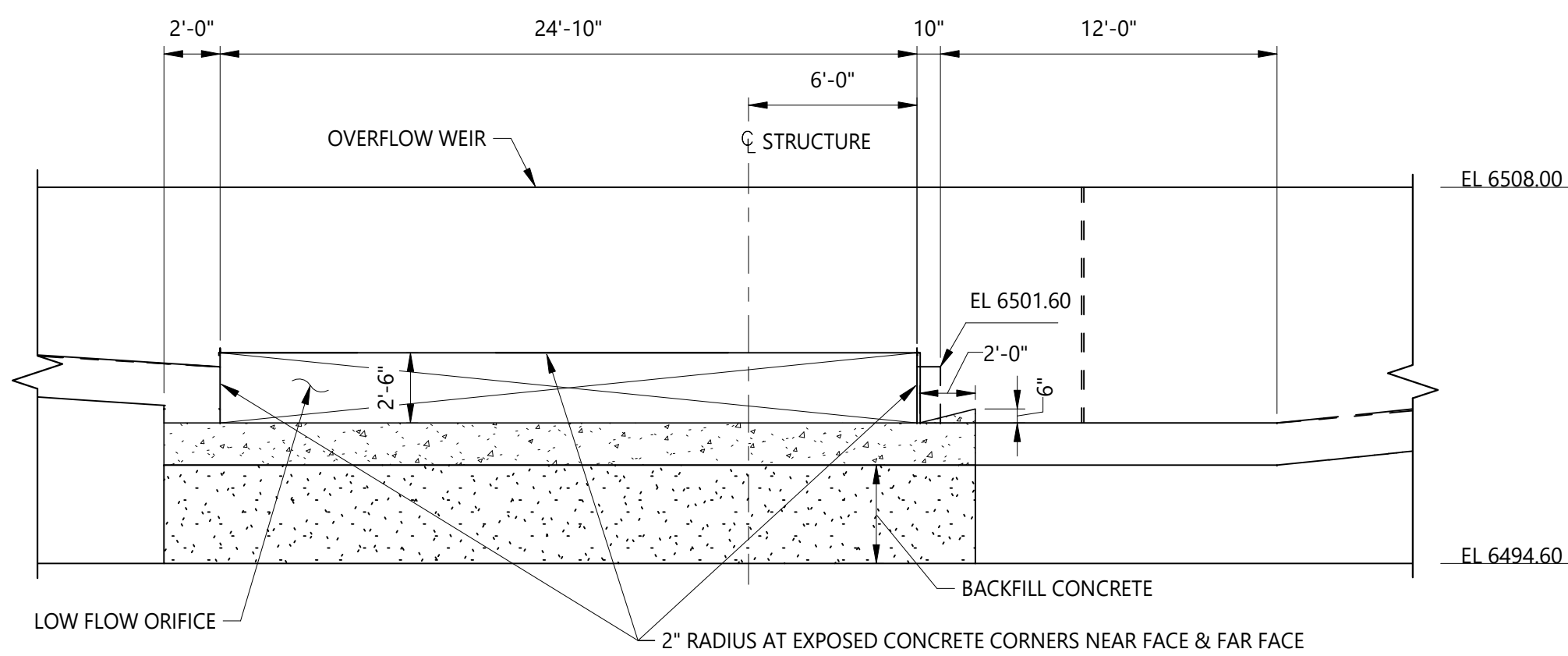

SECTION C - C (S-103)

SCALE: 3/16" = 1'-0"

2" RADIUS AT EXPOSED CONCRETE CORNERS NEAR FACE & FAR FACE

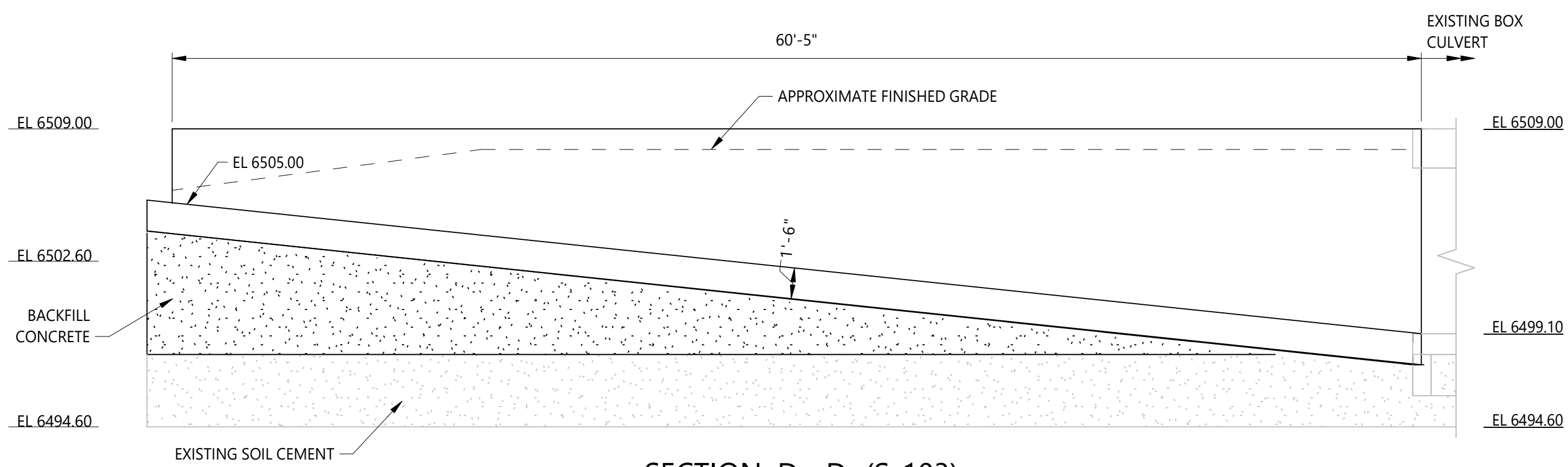

SECTION D - D (S-103)

SCALE: 3/16" = 1'-0"

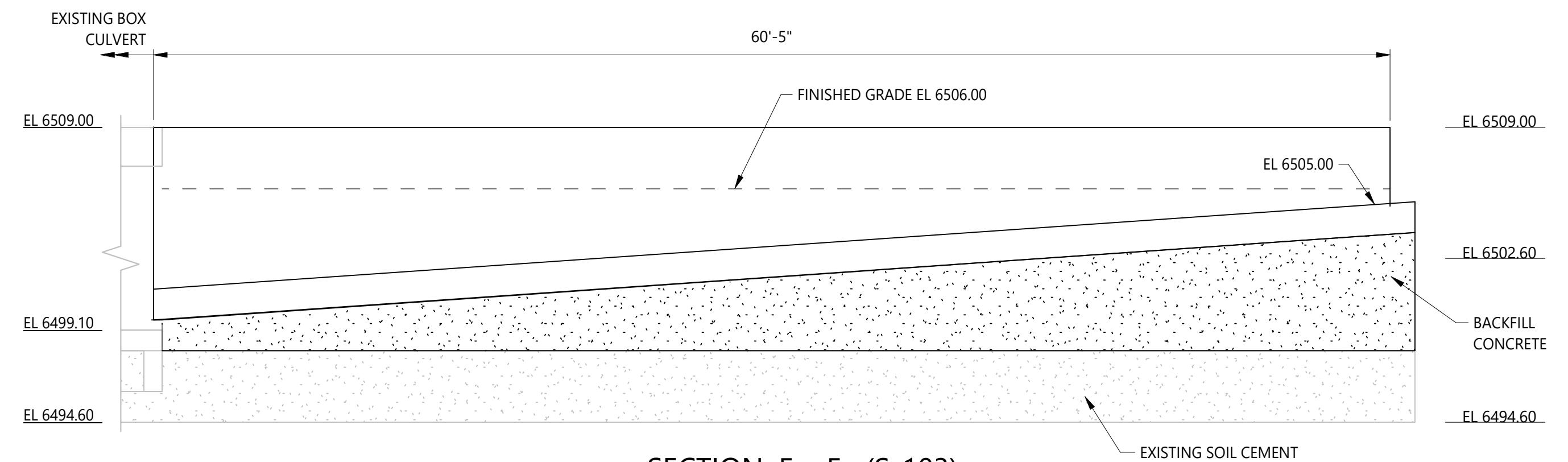

SECTION E - E (S-103)

SCALE: 3/16" = 1'-0"

NOTES:

1. SEE DRAWING S-100 AND S-101 FOR LEGEND, ABBREVIATIONS, AND GENERAL NOTES.
2. PROTECT SOIL CEMENT TO REMAIN.

REV	REVISION DESCRIPTION	DATE	CHND	CHKD	APPR



CITY OF COLORADO SPRINGS
30 S. NEVADA AVE., SUITE 401
COLORADO SPRINGS, CO 80903
(719) 385-5980

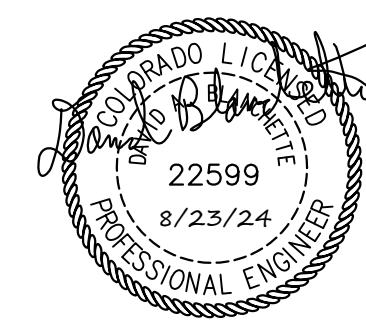
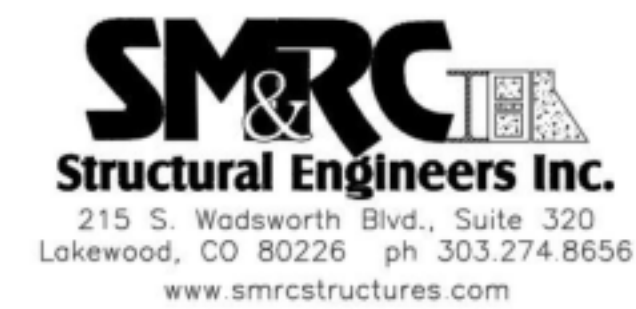

SAND CREEK DETENTION POND NO. 2

POND OUTLET STRUCTURE
OUTLINE SECTIONS

JOB NUMBER	65420975
DATE	8/23/24
DRAWING NO.	S-104
SHEET	37 of 51

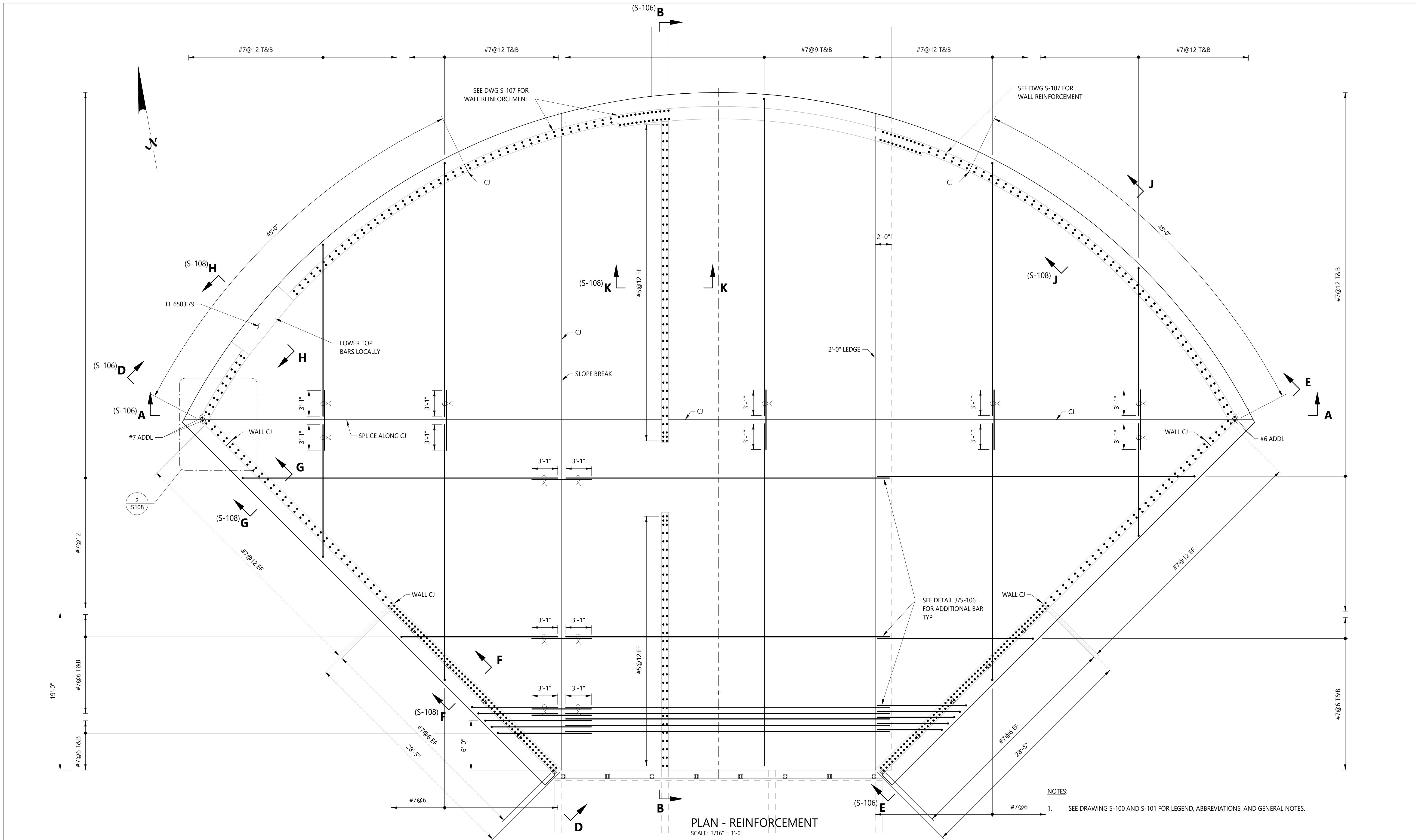

PLAN - REINFORCEMENT
SCALE: 3/16" = 1'-0"

NOTES:
1. SEE DRAWING S-100 AND S-101 FOR LEGEND, ABBREVIATIONS, AND GENERAL NOTES.

REV	REVISION DESCRIPTION	DATE	CHND	CHKD	APPR



CITY OF COLORADO SPRINGS
30 S. NEVADA AVE., SUITE 401
COLORADO SPRINGS, CO 80903
(719) 385-5980

SMRC
Structural Engineers Inc.
215 S. Wadsworth Blvd., Suite 320
Lakewood, CO 80226 ph 303.274.8656
www.smrstructures.com

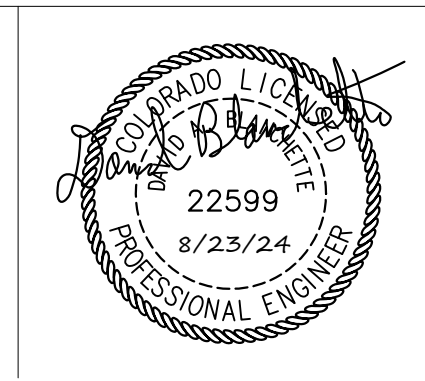

SAND CREEK DETENTION POND NO. 2
POND 5 BOX CULVERT
POND OUTLET STRUCTURE
REINFORCEMENT PLAN

JOB NUMBER	65420975
DATE	8/23/24
DRAWING NO.	S-105
SHEET	38 of 51

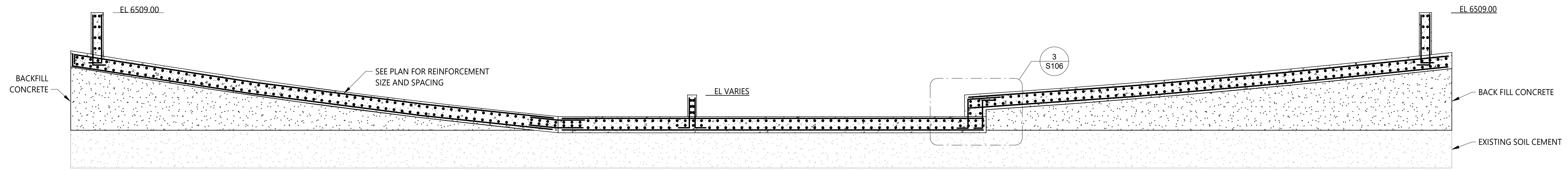

SECTION A - A (S-105)
SCALE: 3/16" = 1'-0"

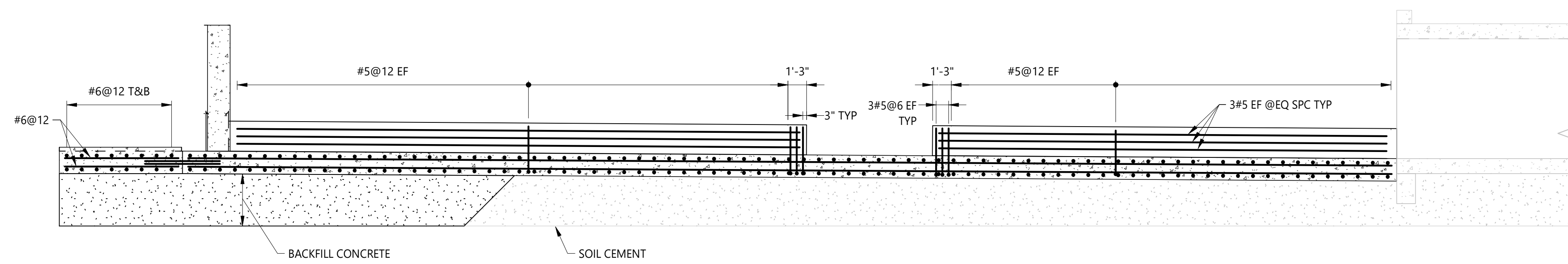

SECTION B - B (S-105)
SCALE: 3/16" = 1'-0"

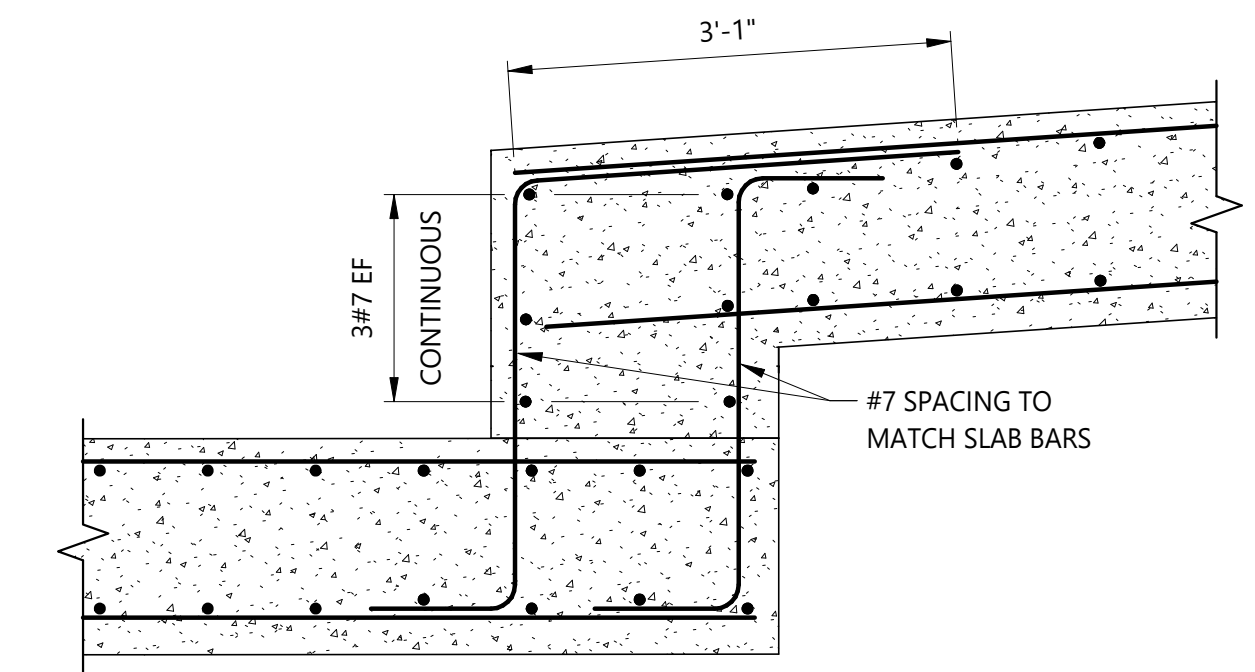

DETAIL 3
SCALE: 3/4" = 1'-0"

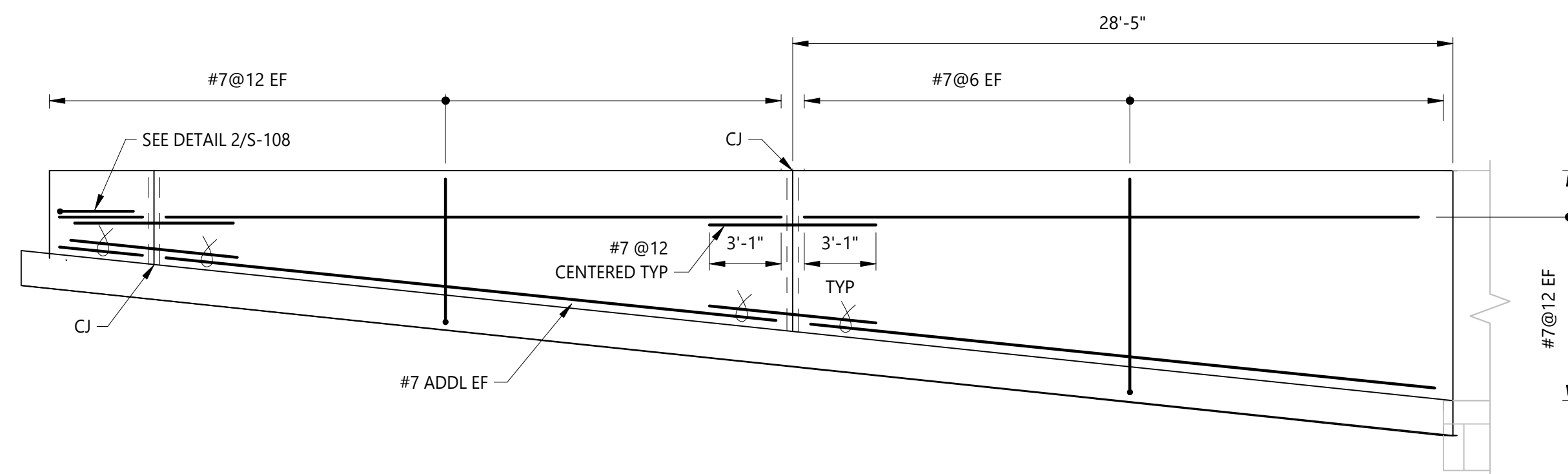

SECTION D - D (S-105)
SCALE: 3/16" = 1'-0"

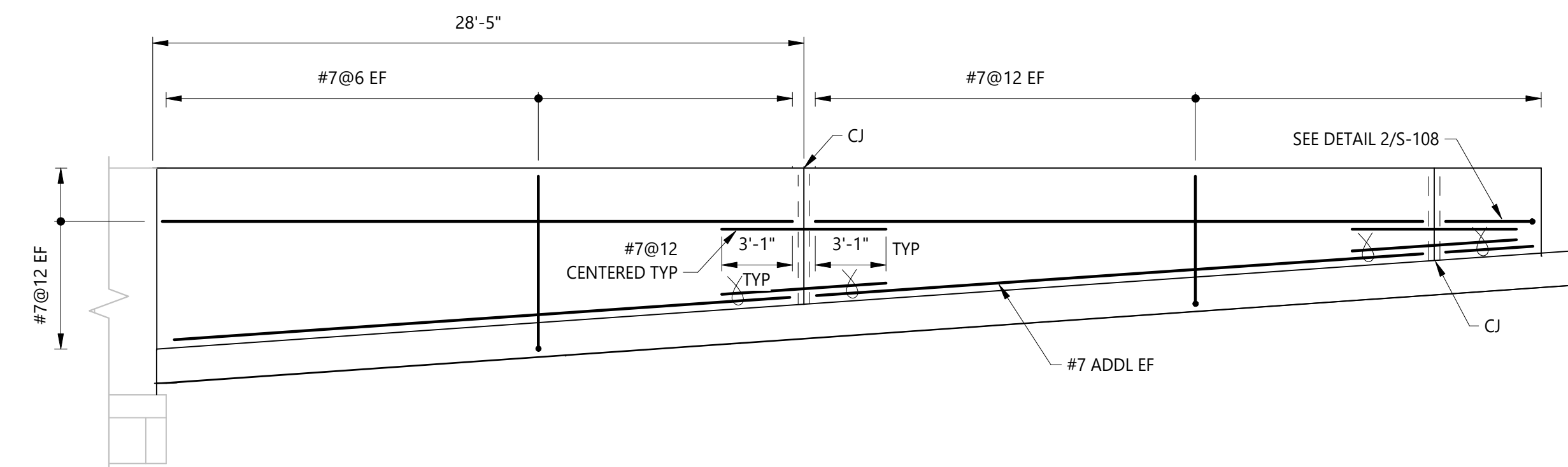

SECTION E - E (S-105)
SCALE: 3/16" = 1'-0"

REV	REVISION DESCRIPTION	DATE	CHND	CHKD	APPR

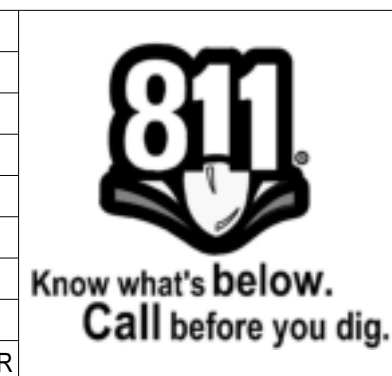

CITY OF COLORADO SPRINGS
30 S. NEVADA AVE., SUITE 401
COLORADO SPRINGS, CO 80903
(719) 385-5980

SMRC
Structural Engineers Inc.
215 S. Wadsworth Blvd., Suite 320
Lakewood, CO 80226 ph 303.274.8656
www.smrstructures.com

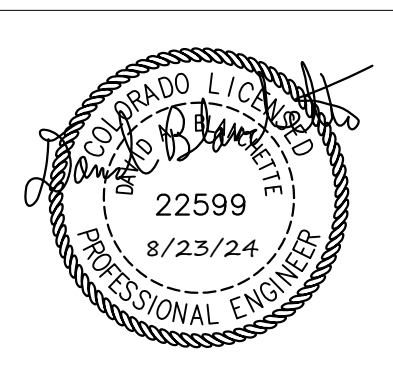

SAND CREEK DETENTION POND NO. 2

POND OUTLET STRUCTURE
REINFORCEMENT SECTIONS

JOB NUMBER 65420975
DATE 8/23/24
DRAWING NO. S-106
SHEET 39 of 51

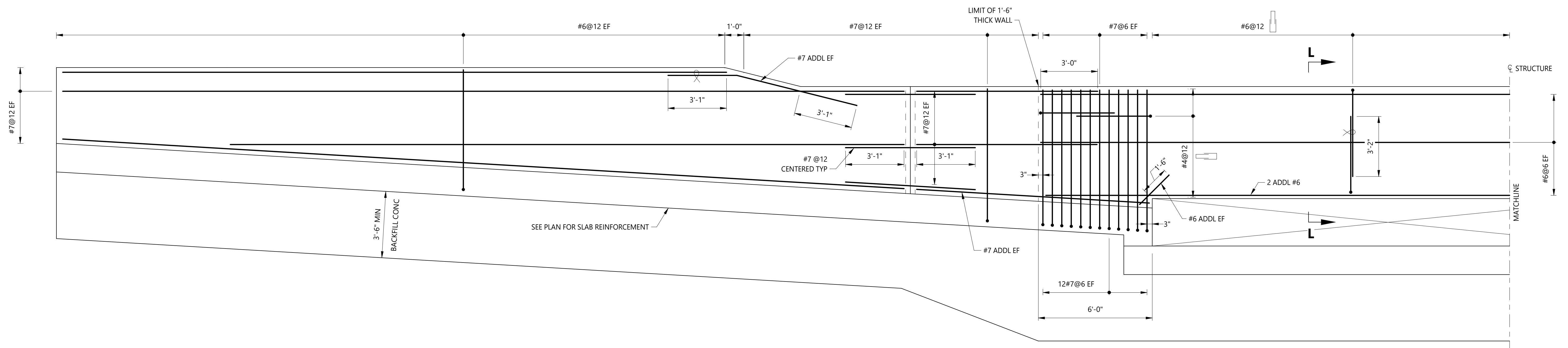

ELEVATION - CURVED WEIR WALL (LOOKING SOUTH)
SCALE: 3/8" = 1'-0"

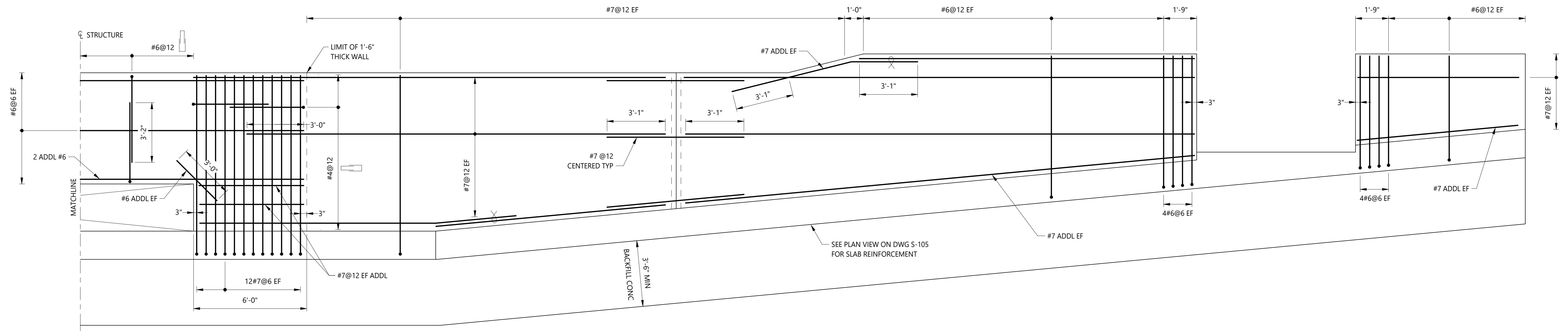

ELEVATION - CURVED WEIR WALL (LOOKING SOUTH)
SCALE: 3/8" = 1'-0"

REV	REVISION DESCRIPTION	DATE	CHND	CHKD	APPR



CITY OF COLORADO SPRINGS
30 S. NEVADA AVE., SUITE 401
COLORADO SPRINGS, CO 80903
(719) 385-5980

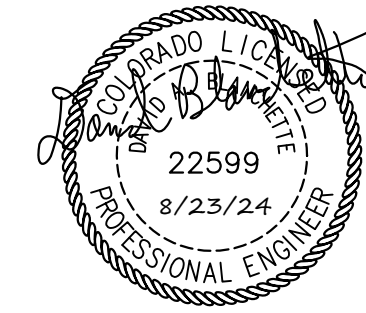
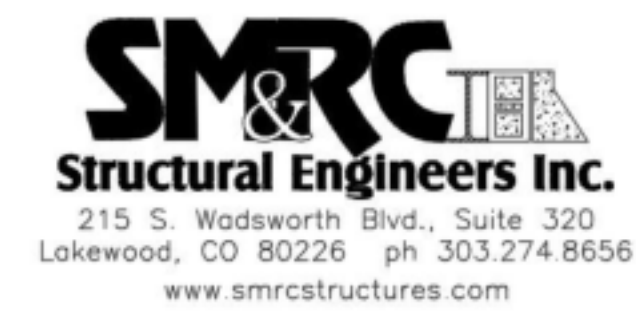

SAND CREEK DETENTION POND NO. 2

POND OUTLET STRUCTURE
REINFORCEMENT SECTIONS

JOB NUMBER	65420975
DATE	8/23/24
DRAWING NO.	S-107
SHEET	40 of 51

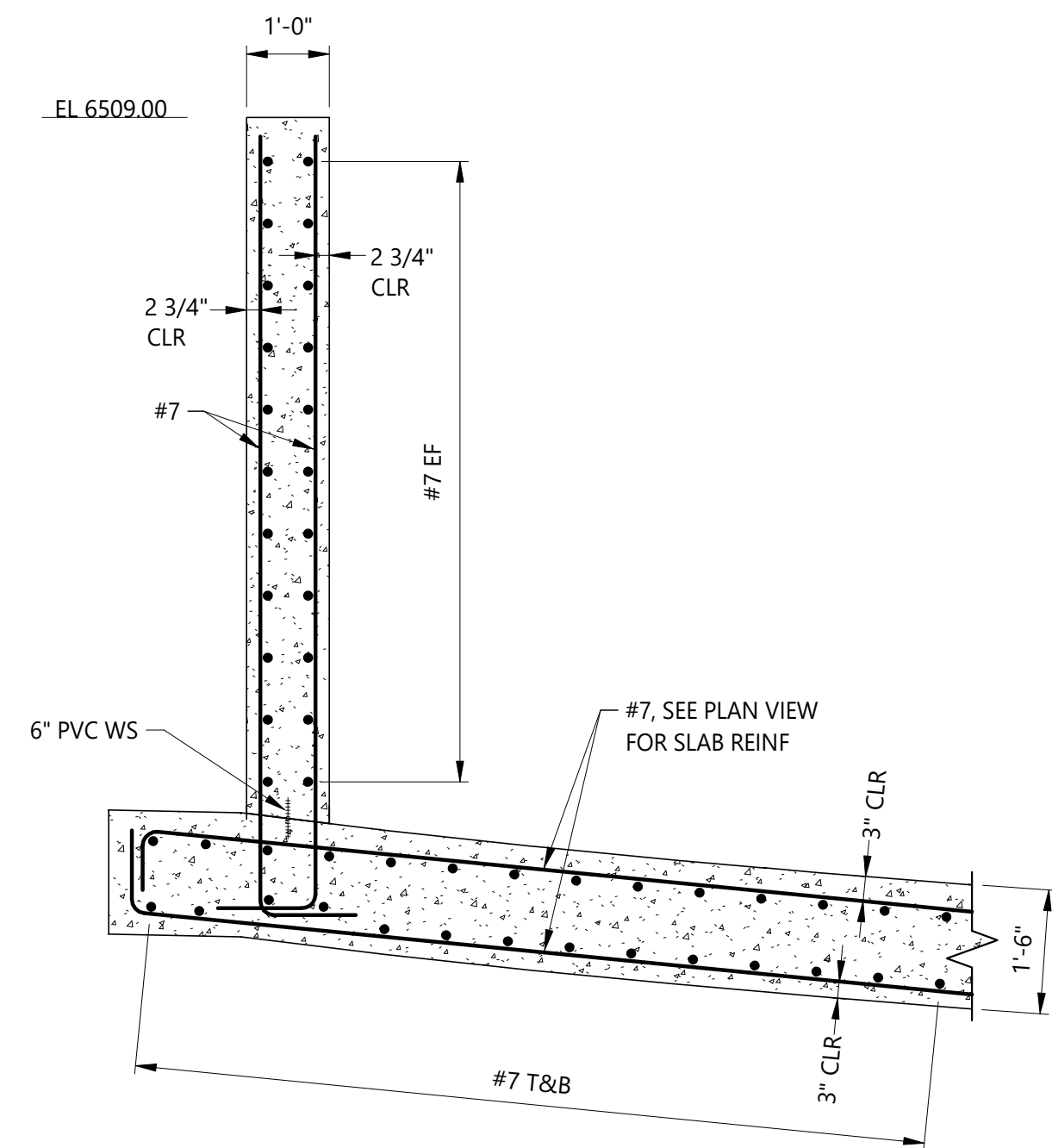

SECTION F - F (S-105)
SCALE: 1/2" = 1'-0"

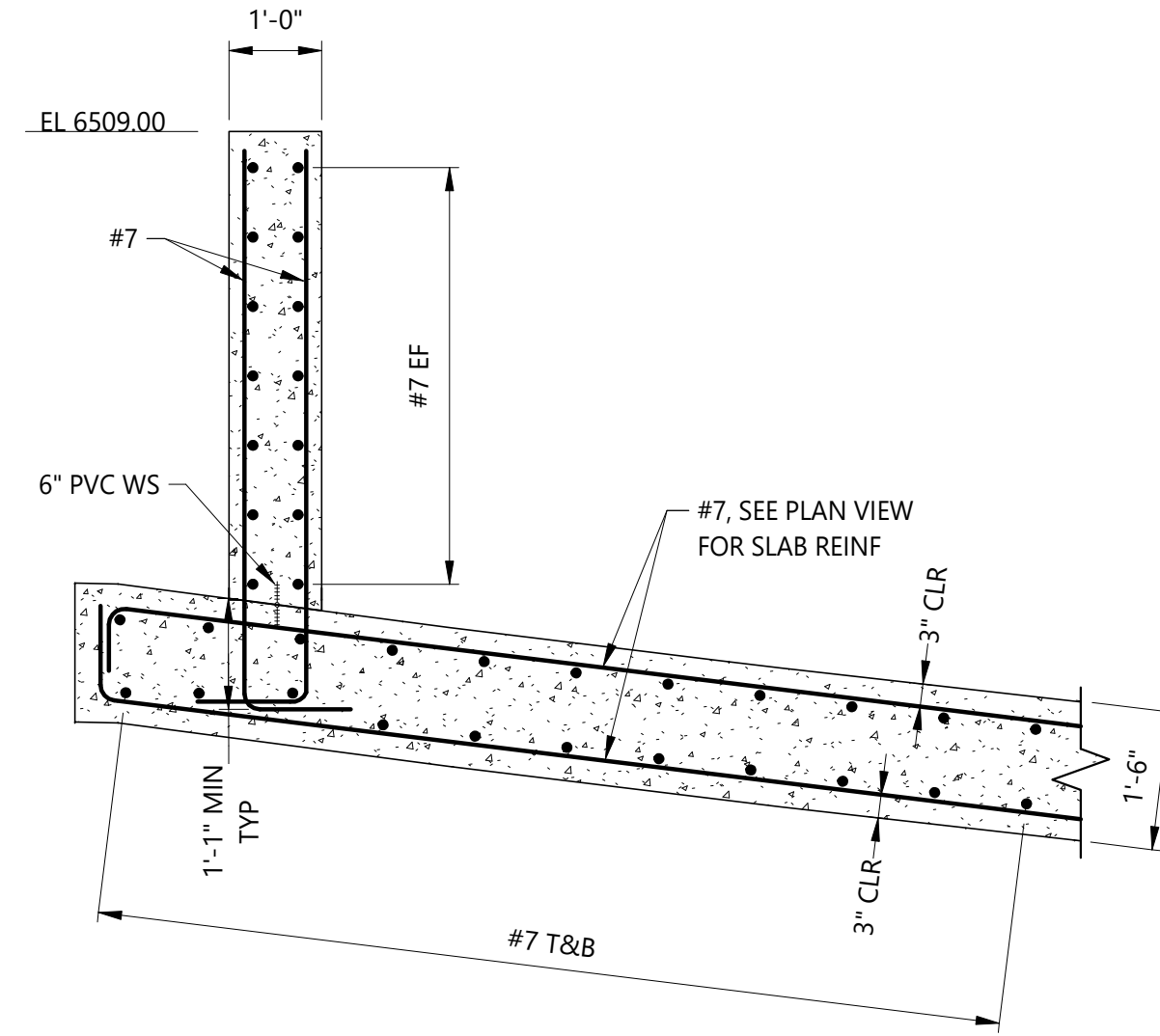

SECTION G - G (S-105)
SCALE: 1/2" = 1'-0"

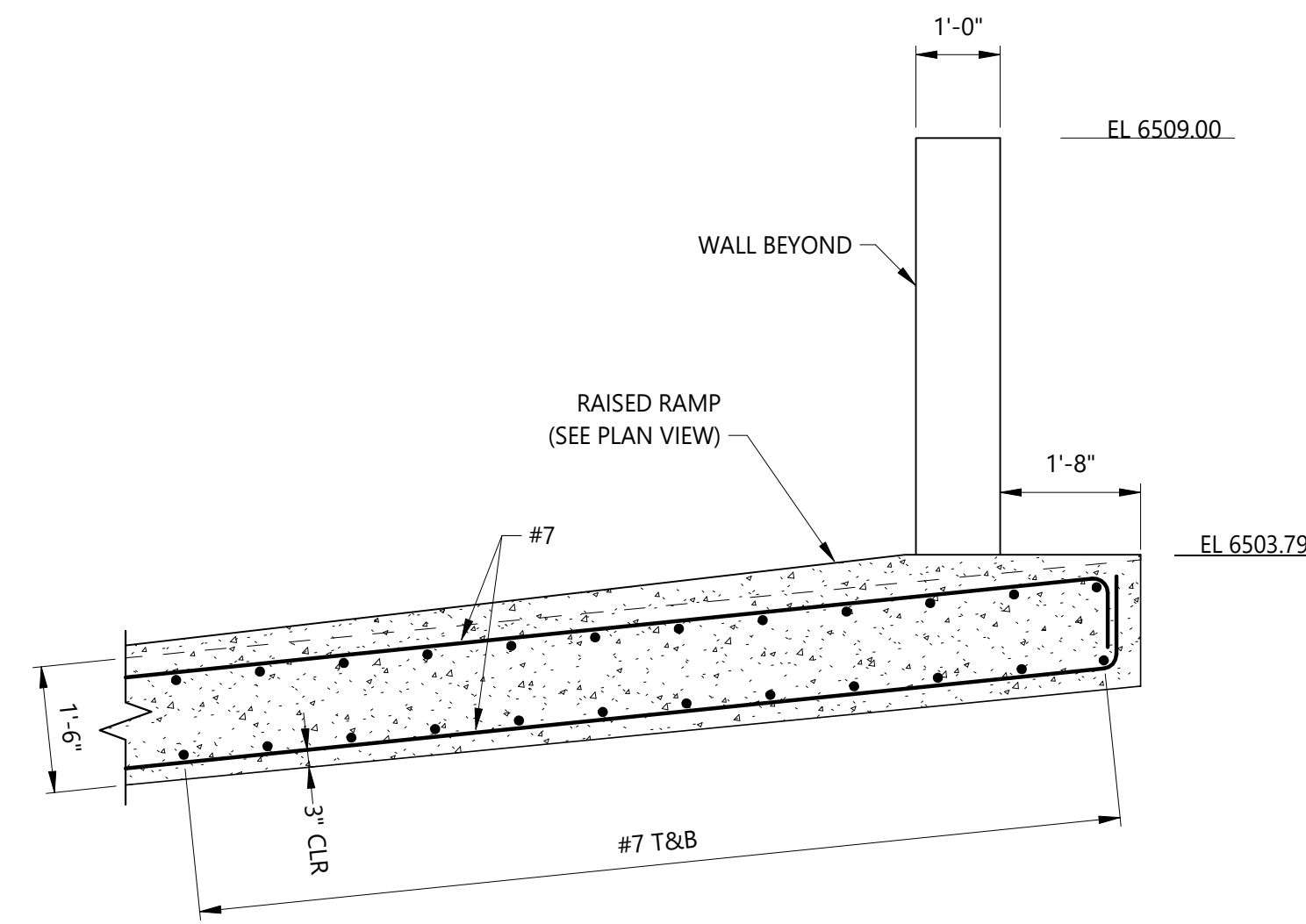

SECTION H - H (S-105)
SCALE: 1/2" = 1'-0"

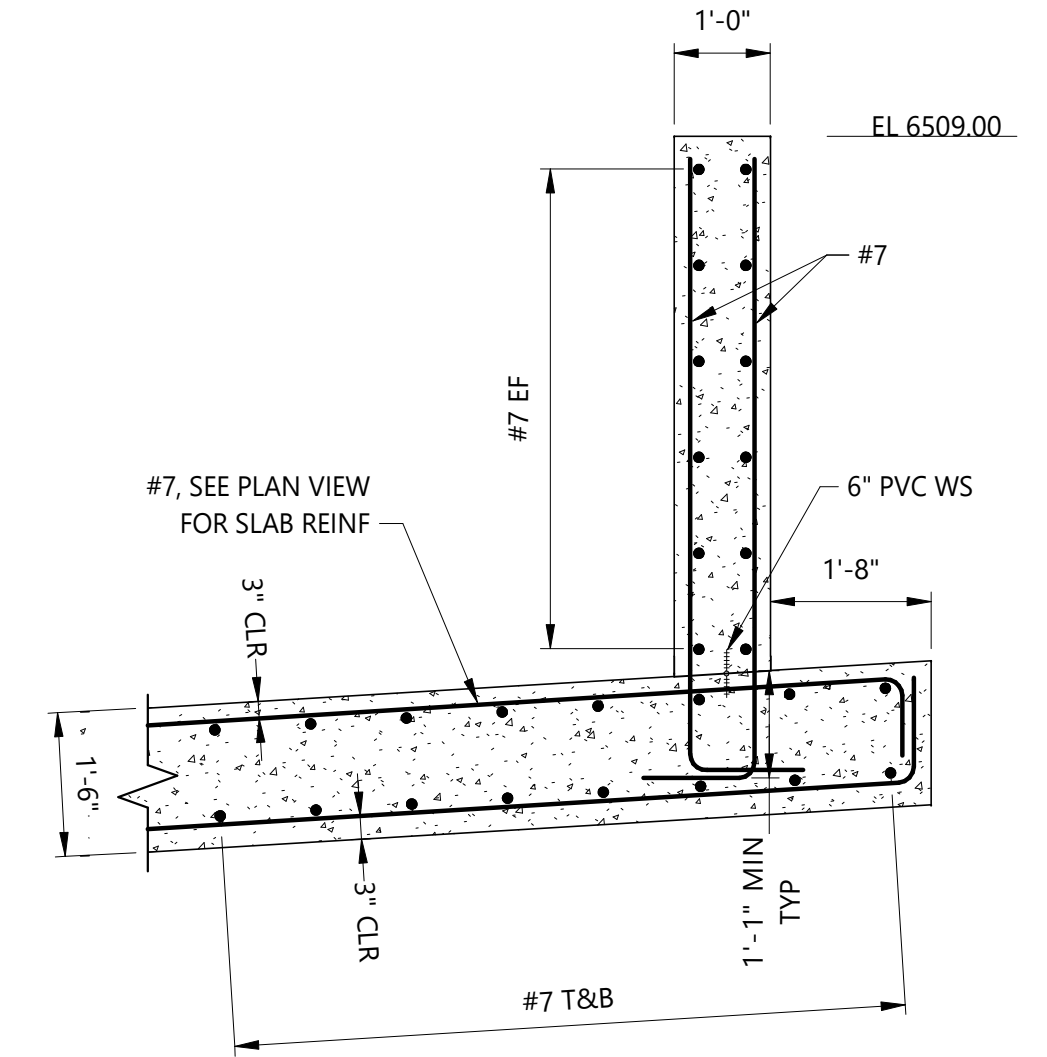

SECTION J - J (S-105)
SCALE: 1/2" = 1'-0"

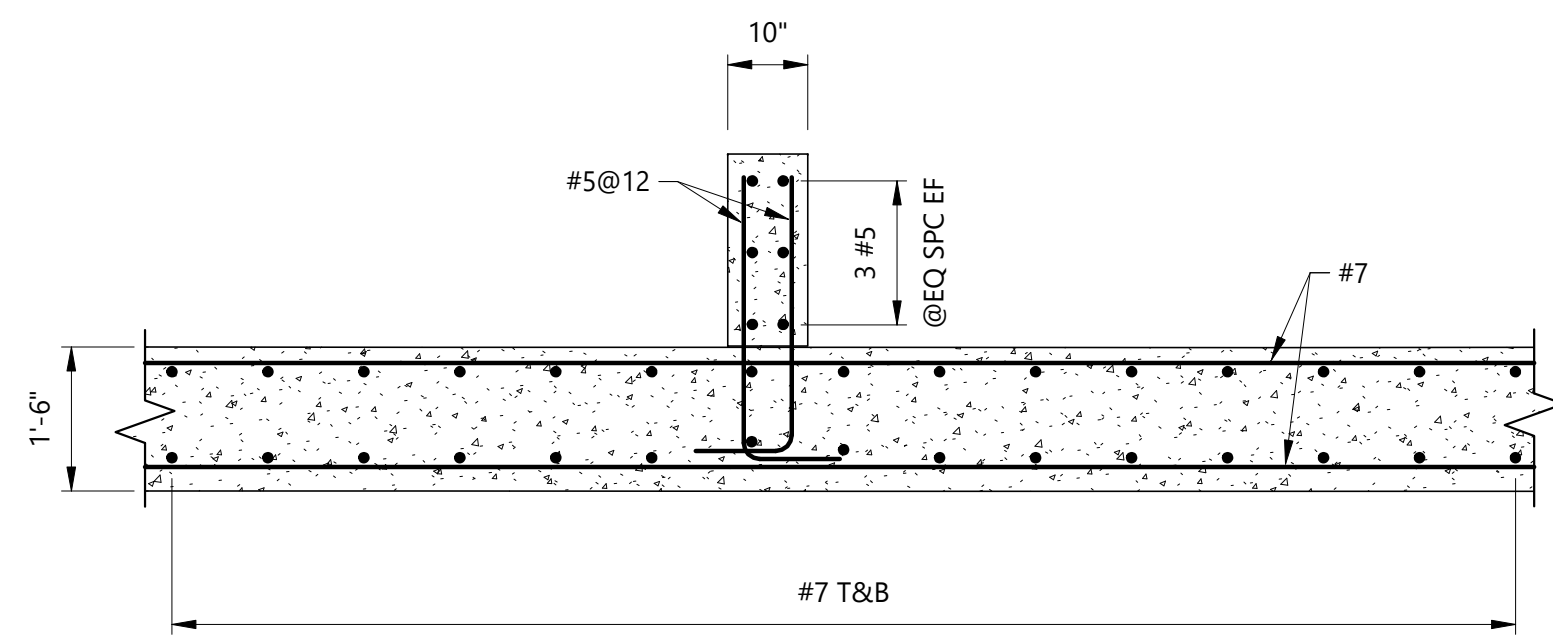

SECTION K - K (S-105)
SCALE: 1/2" = 1'-0"

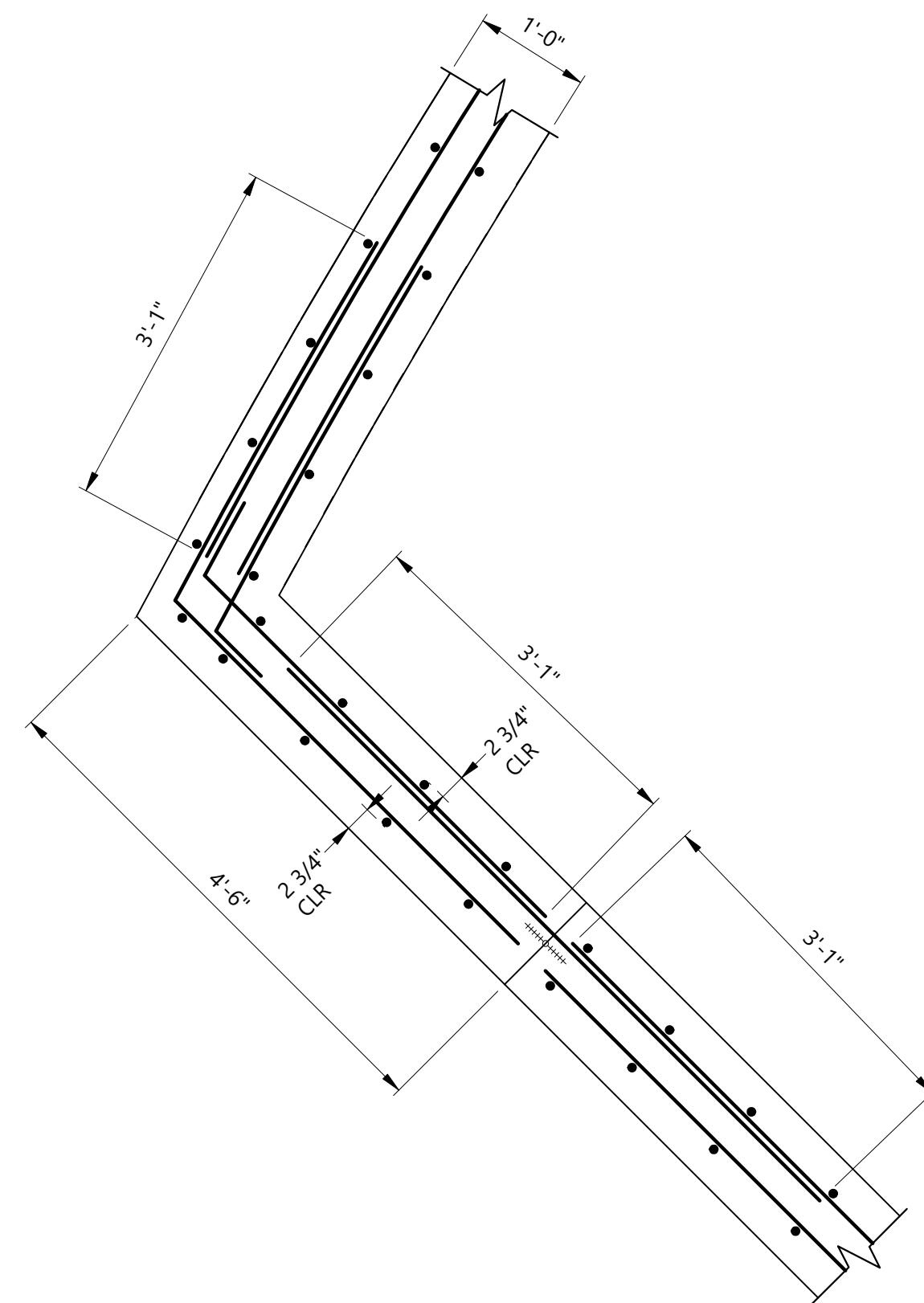

DETAIL 2 (S-105)
SCALE: 3/4" = 1'-0"

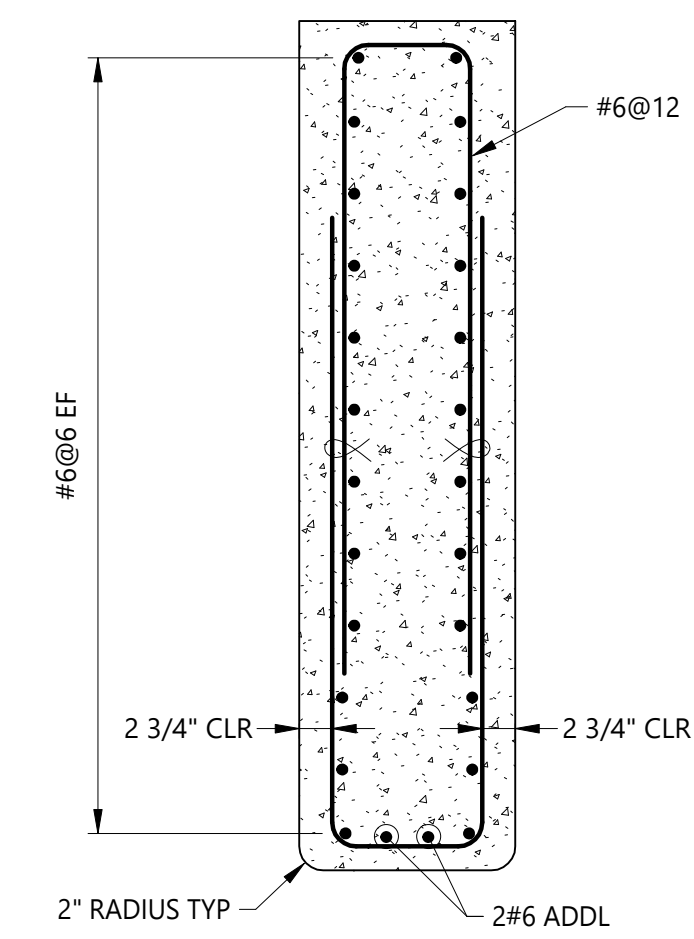

SECTION L-L (S-107)
SCALE: 3/4" = 1'-0"

REV	REVISION DESCRIPTION	DATE	CHND	CHKD	APPR



CITY OF COLORADO SPRINGS
30 S. NEVADA AVE., SUITE 401
COLORADO SPRINGS, CO 80903
(719) 385-5980



SAND CREEK DETENTION POND NO. 2

POND OUTLET STRUCTURE
REINFORCEMENT SECTIONS

JOB NUMBER	65420975
DATE	8/23/24
DRAWING NO.	S-108
SHEET	41 of 51

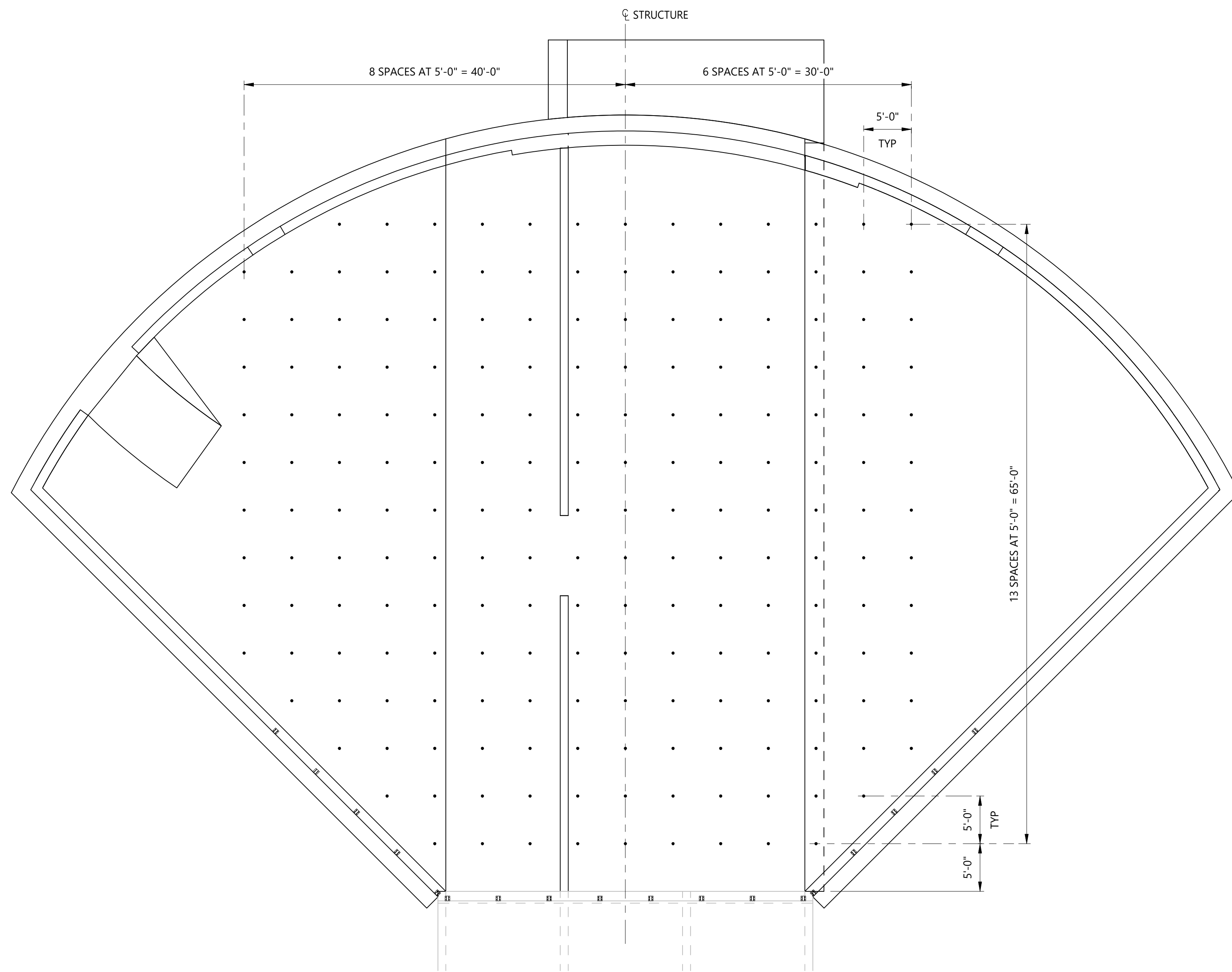

PLAN - DOWEL ANCHORS
SCALE: 1/8" = 1'-0"

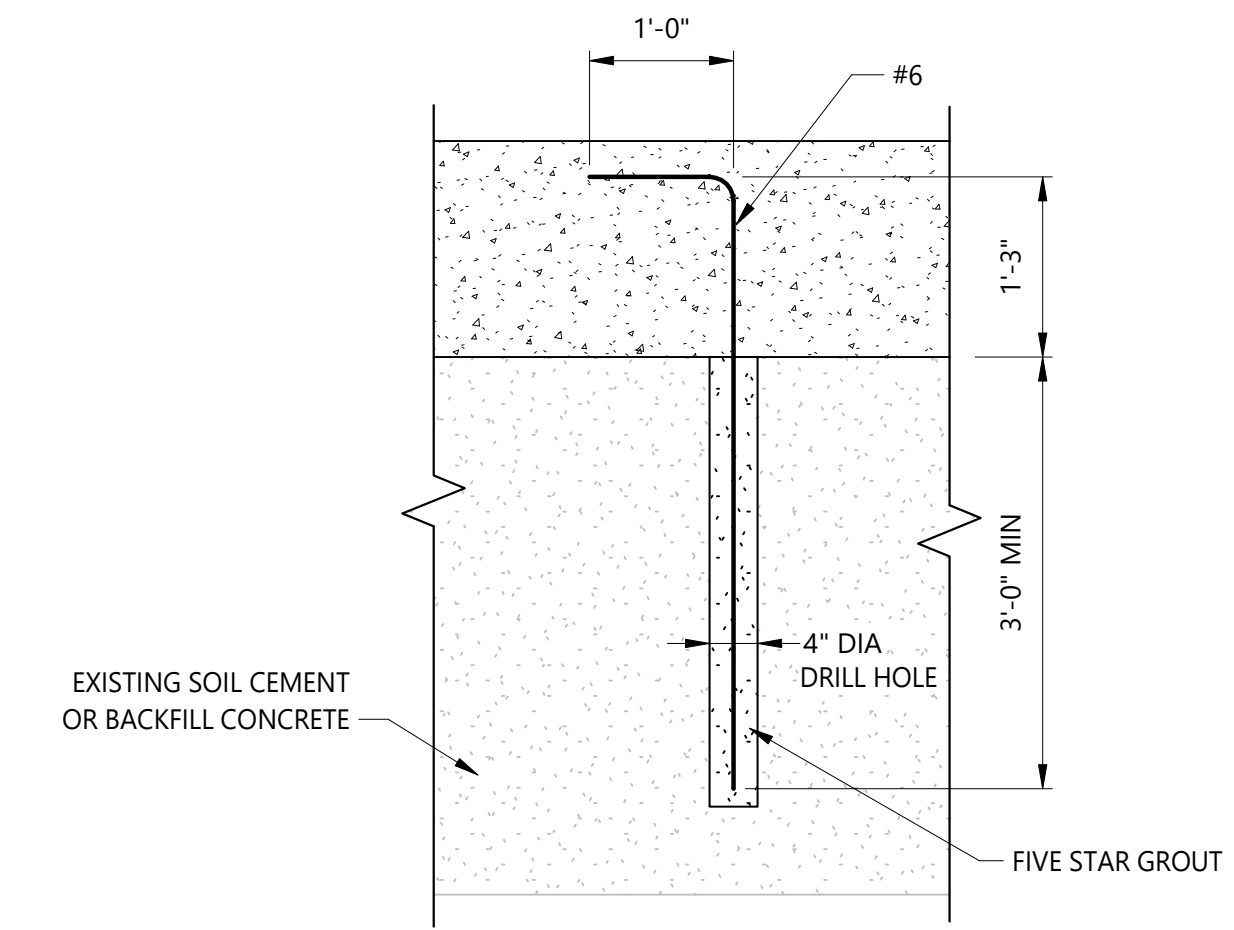

ANCHOR DETAIL
SCALE: 3/4" = 1'-0"

REV	REVISION DESCRIPTION	DATE	CHND	CHKD	APPR



CITY OF COLORADO SPRINGS
30 S. NEVADA AVE., SUITE 401
COLORADO SPRINGS, CO 80903
(719) 385-5980

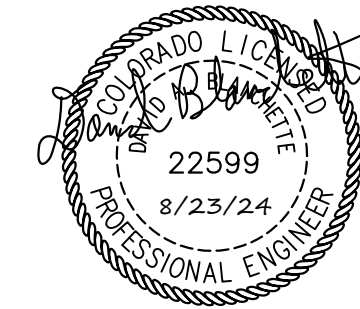

SAND CREEK DETENTION POND NO. 2

POND OUTLET STRUCTURE
DOWEL ANCHOR PLAN AND DETAILS

JOB NUMBER	65420975
DATE	8/23/24
DRAWING NO.	S-109
SHEET	42 of 51

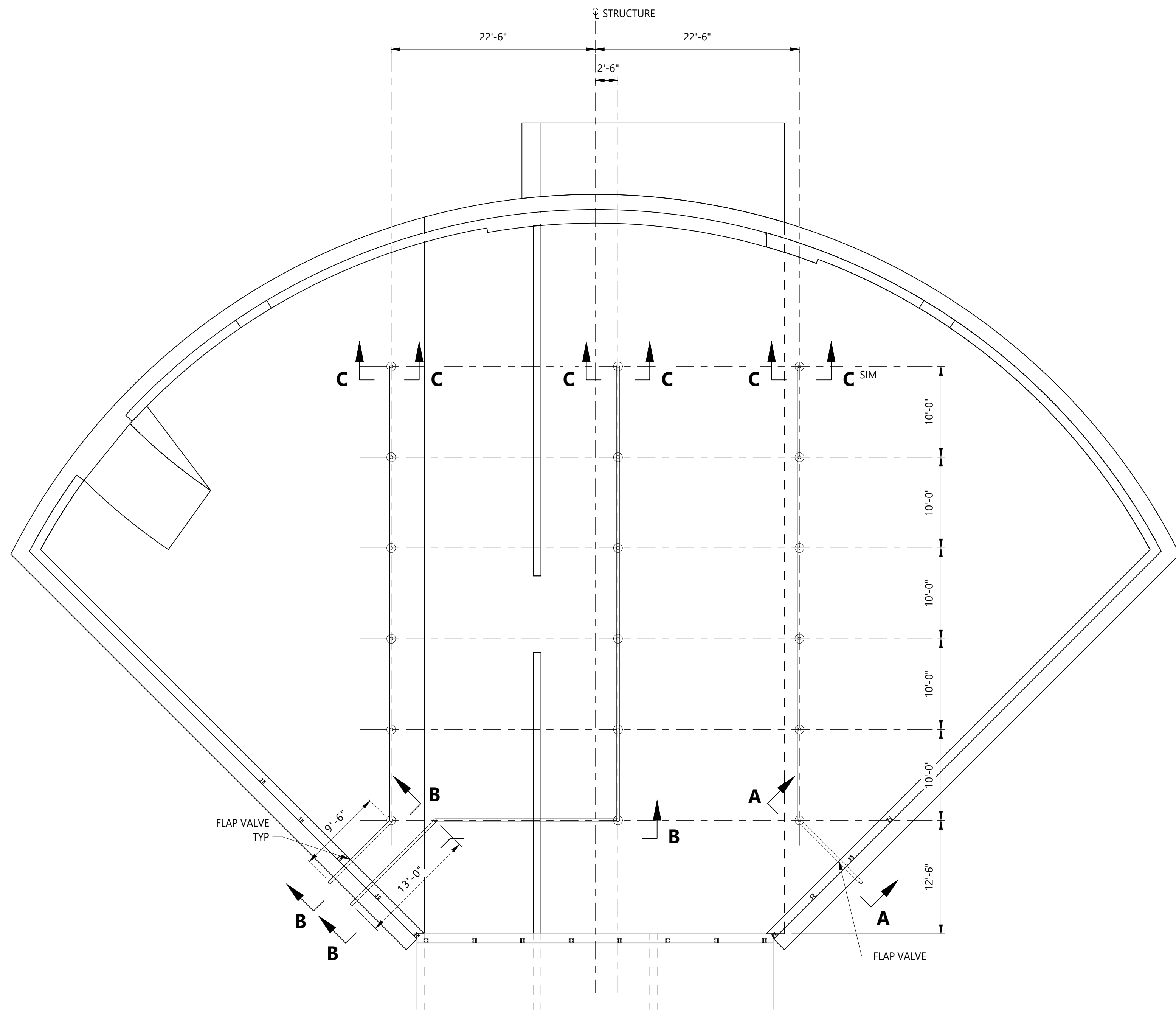

PLAN - DRAIN SYSTEM
SCALE: 1/8" = 1'-0"

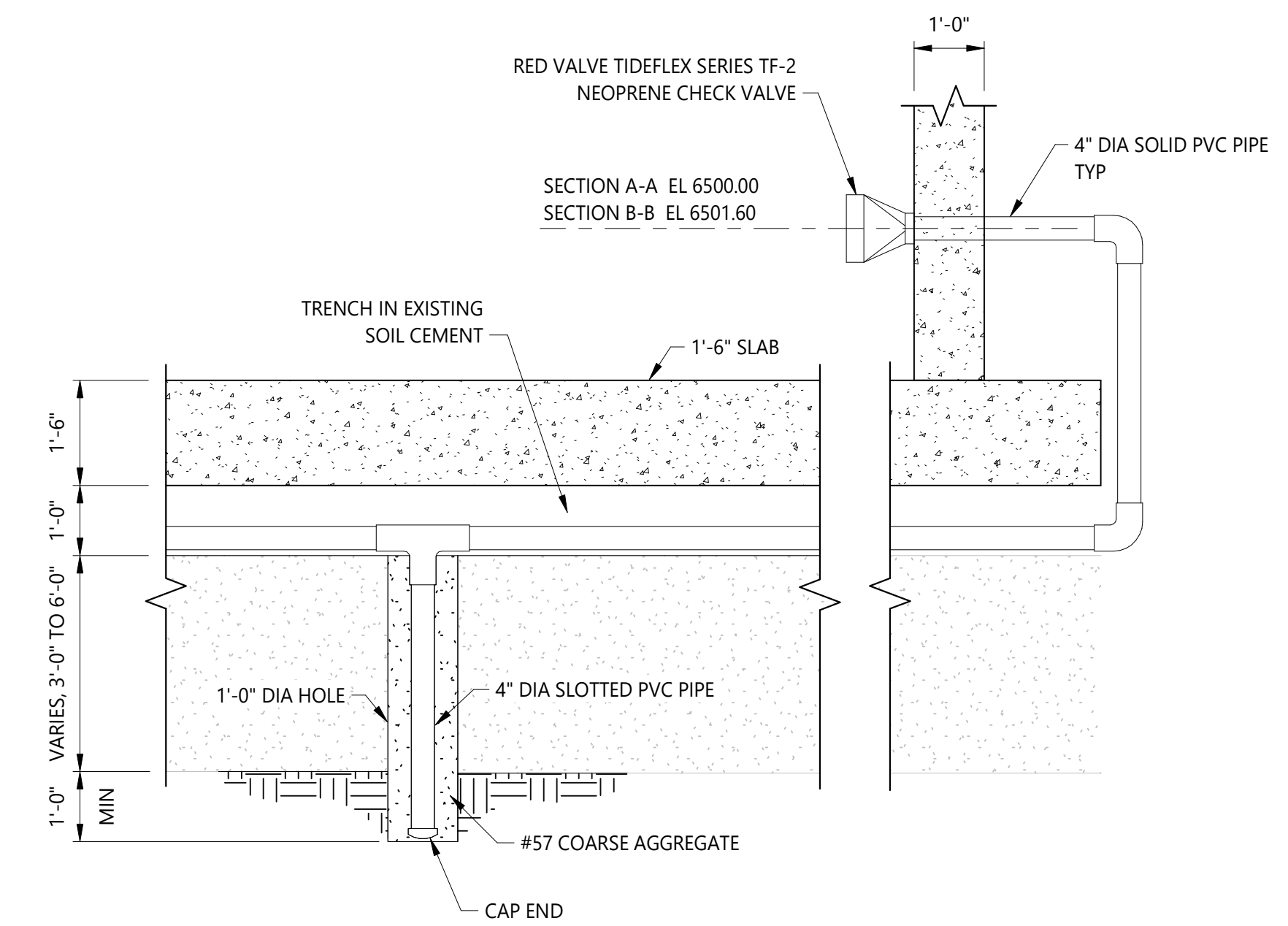

SECTION A-A - DRAINAGE PIPE (SECTION B-B SIMILAR)
SCALE: 1/2" = 1'-0"

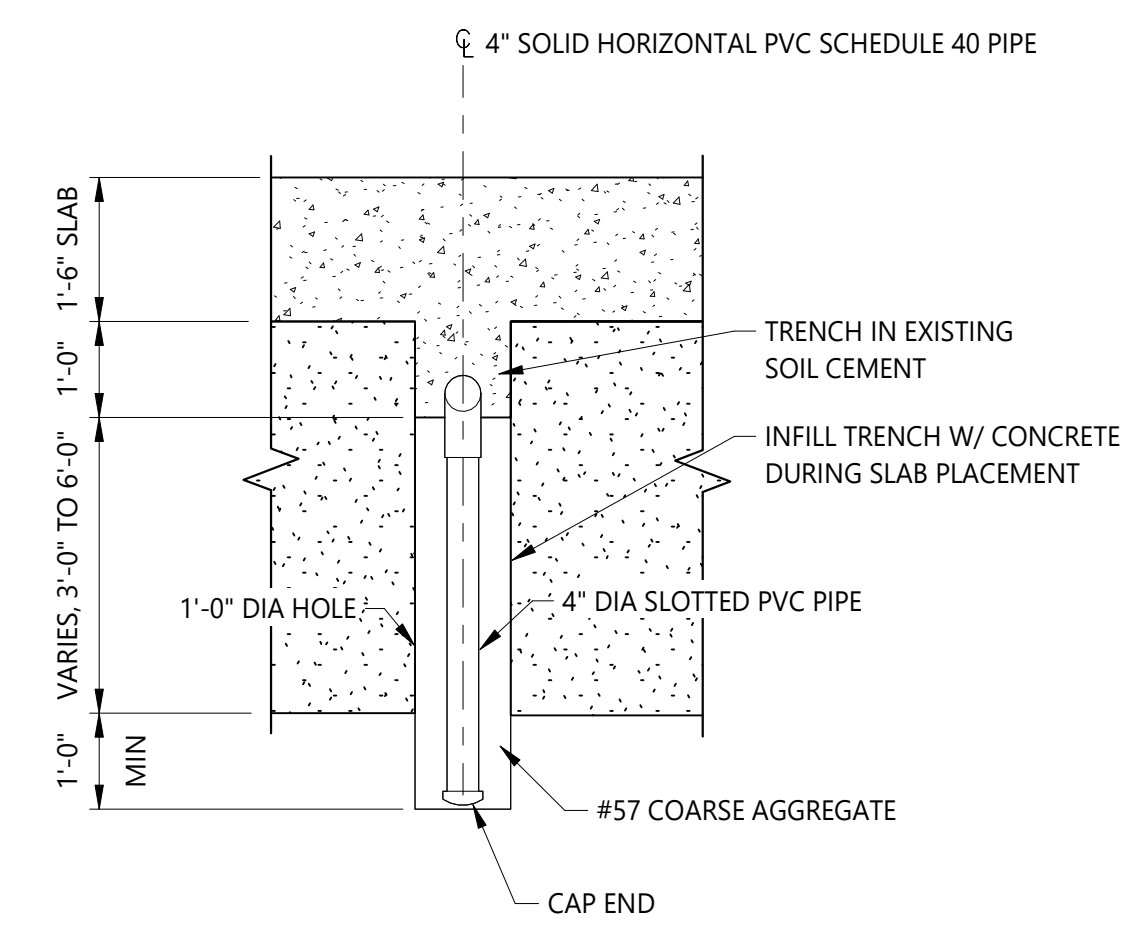

SECTION C-C - DRAINAGE PIPE
SCALE: 1/2" = 1'-0"

REV	REVISION DESCRIPTION	DATE	CHND	CHKD	APPR



CITY OF COLORADO SPRINGS
30 S. NEVADA AVE., SUITE 401
COLORADO SPRINGS, CO 80903
(719) 385-5980

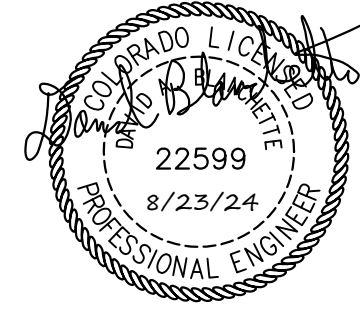

SAND CREEK DETENTION POND NO. 2
POND OUTLET STRUCTURE
UNDER DRAIN PLAN AND DETAILS

JOB NUMBER	65420975
DATE	8/23/24
DRAWING NO.	S-110
SHEET	43 of 51

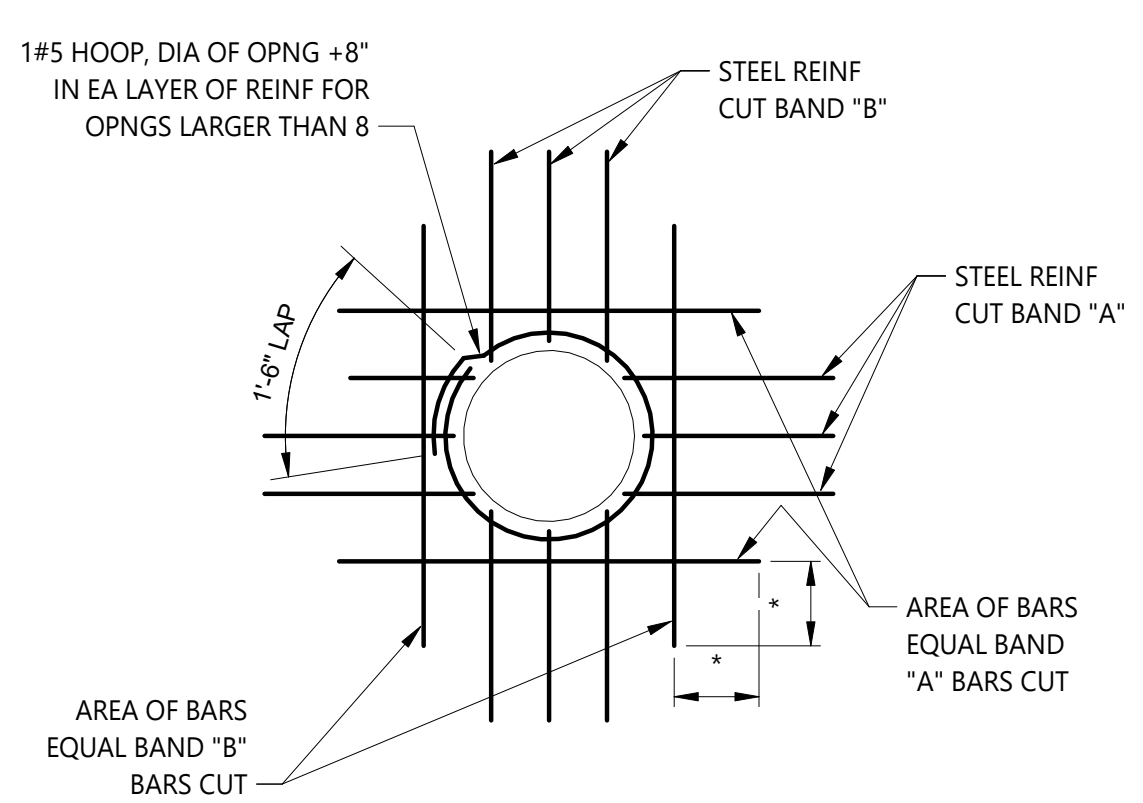

- OPENING REINFORCEMENT NOTES:**
1. TYPICAL FOR ALL OPENINGS IN CONCRETE WALLS AND SLABS UNLESS INDICATED OTHERWISE ON PLANS.
 2. DO NOT WELD REINFORCEMENT TO PIPE SLEEVES AND INSERTS.
 3. PROVIDE A MINIMUM OF (2) "A" BARS AND (2) "B" BARS EACH SIDE OF OPENING (ONE EACH FACE).
 4. SPACE AT 3 BAR DIAMETERS ON CENTER (3" MINIMUM).
 5. * PROVIDE MINIMUM LAP AS NOTED OR SHOWN ON PLANS, TYPICAL. PROVIDE STD HOOK IF FULL LAP LENGTH IS NOT POSSIBLE.

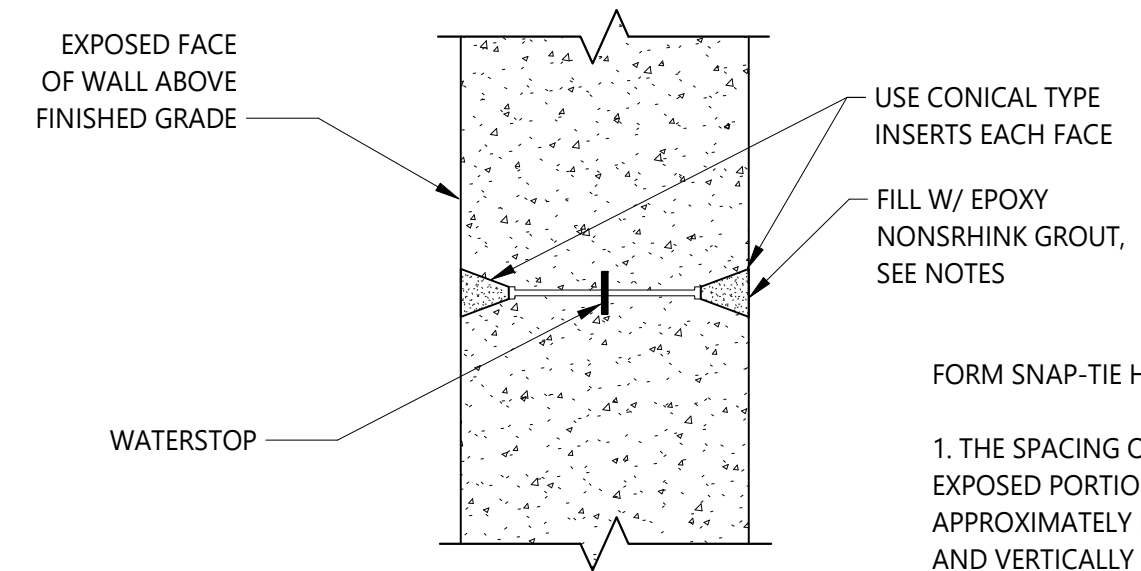
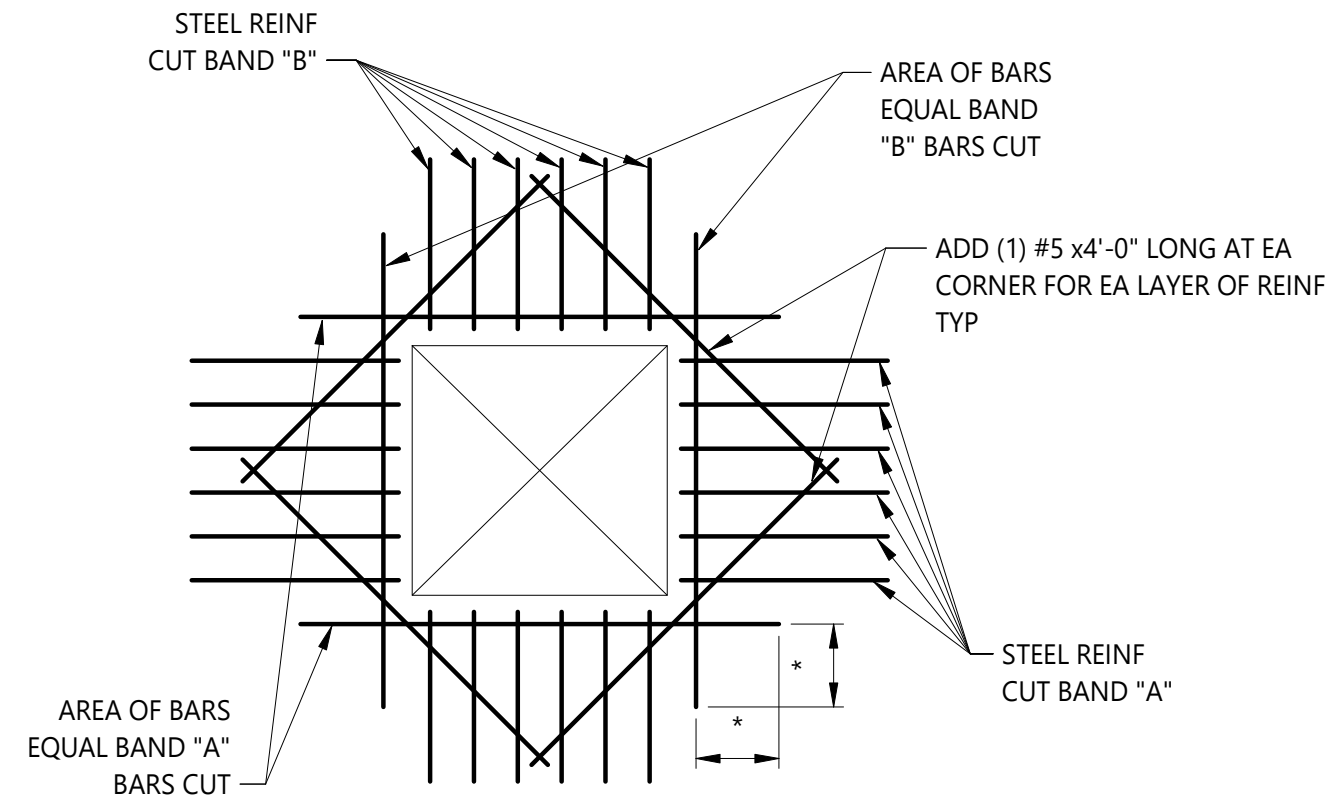

- FORM SNAP-TIE HOLE NOTES:**
1. THE SPACING OF FORM TIES ON EXPOSED PORTIONS OF WALLS SHALL BE APPROXIMATELY EQUAL HORIZONTALLY AND VERTICALLY AND SHALL BE UNIFORM IN EACH DIRECTION.
 2. DRY PACK TIE HOLES WITH EPOXY NON SHRINK GROUT WITH COLOR OF GROUT TO MATCH COLOR OF CONCRETE.

TYPICAL FORM SNAP - TIE JOINT
SCALE: N.T.S.

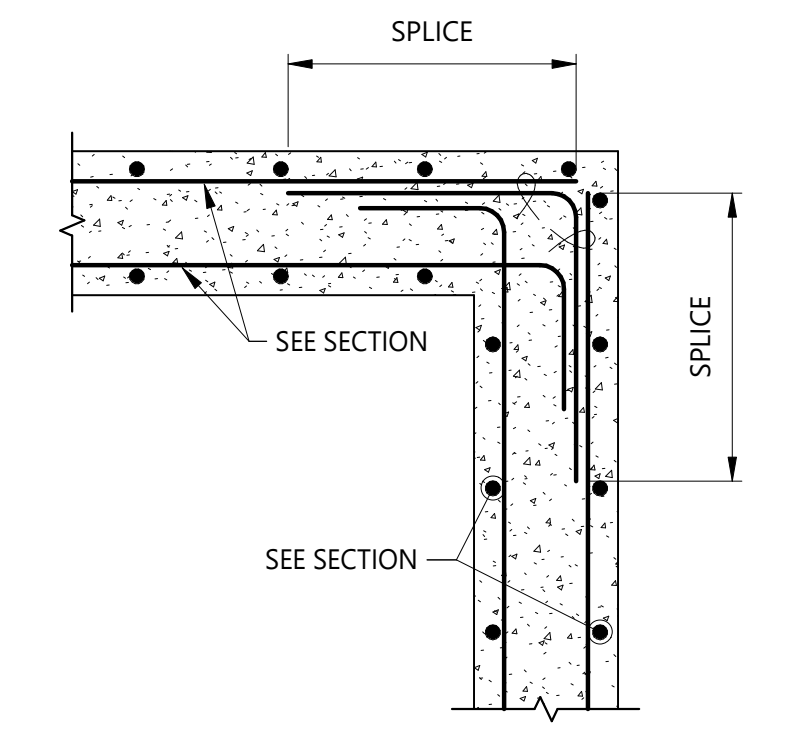

TYPICAL CORNER INTERSECTION
SCALE: N.T.S.

DETAIL 1 - TYPICAL OPENING REINFORCEMENT
DETAIL N.T.S.

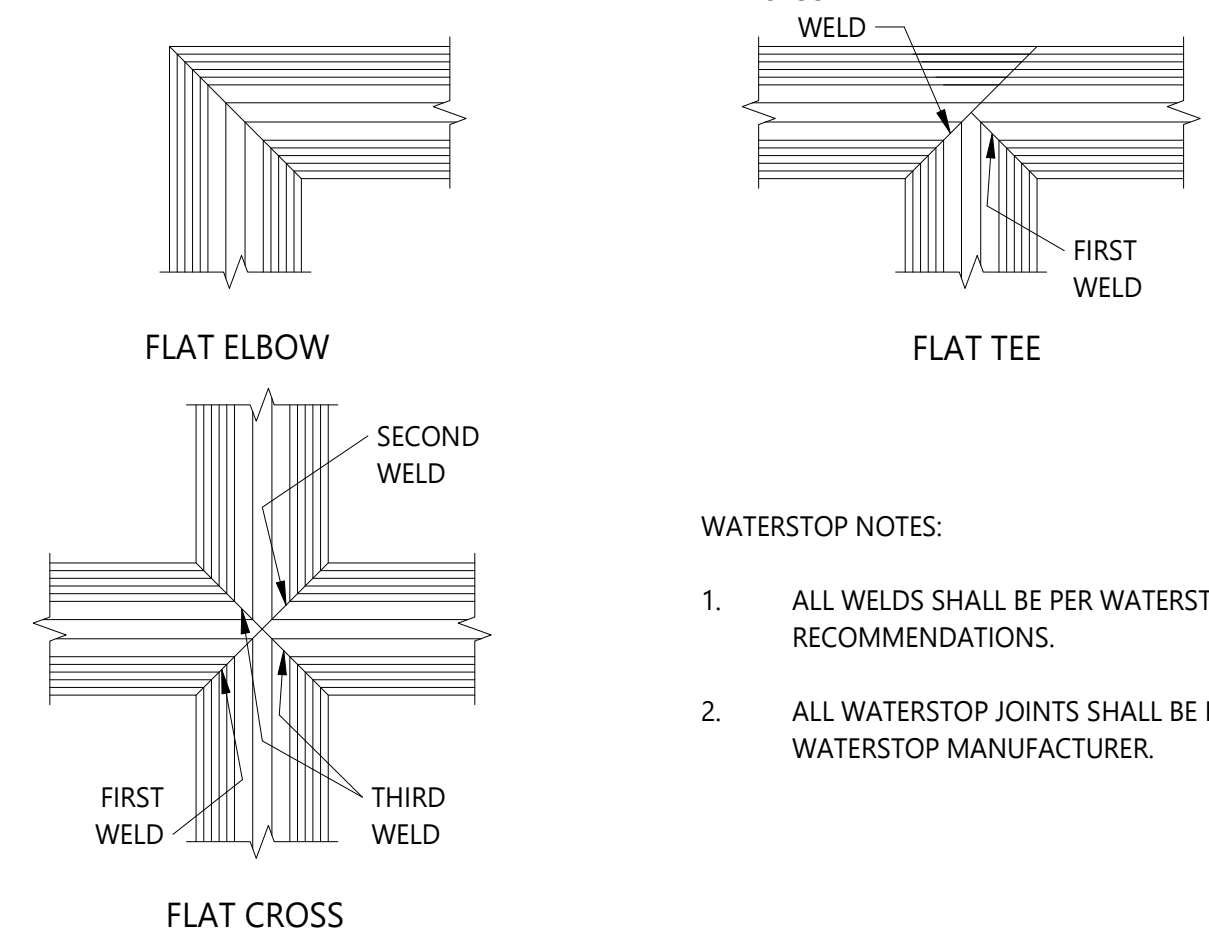
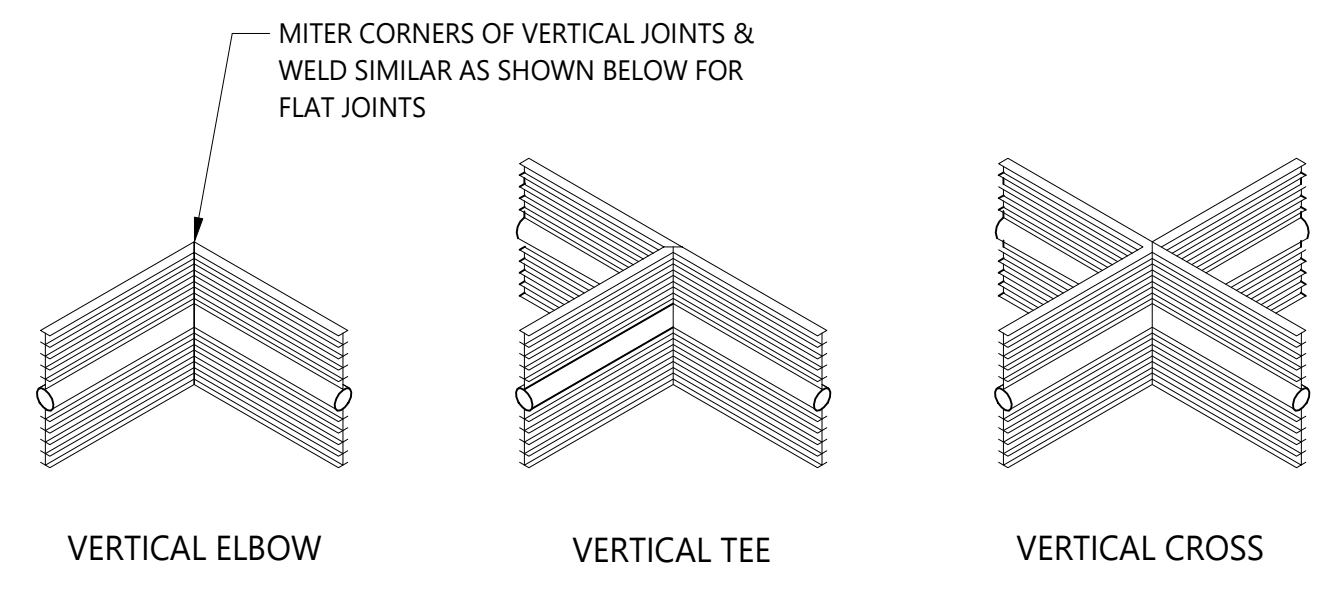

- WATERSTOP NOTES:**
1. ALL WELDS SHALL BE PER WATERSTOP MANUFACTURER'S RECOMMENDATIONS.
 2. ALL WATERSTOP JOINTS SHALL BE PRE-FABRICATED BY WATERSTOP MANUFACTURER.

WATERSTOP JOINT
DETAIL N.T.S.

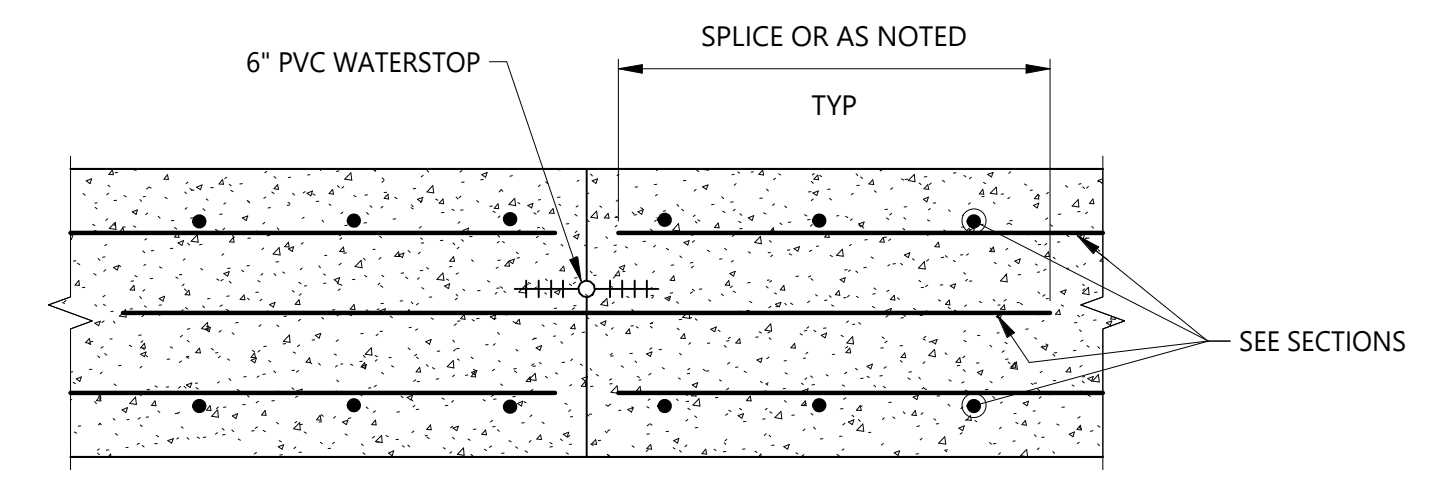

OUTLET VERTICAL WALL CONSTRUCTION JOINT
SCALE: 1 1/2" = 1'-0"

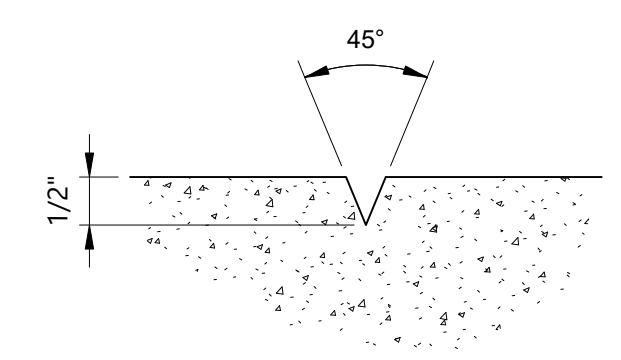

DETAIL 1 - V-JOINT
SCALE: 6" = 1'-0"

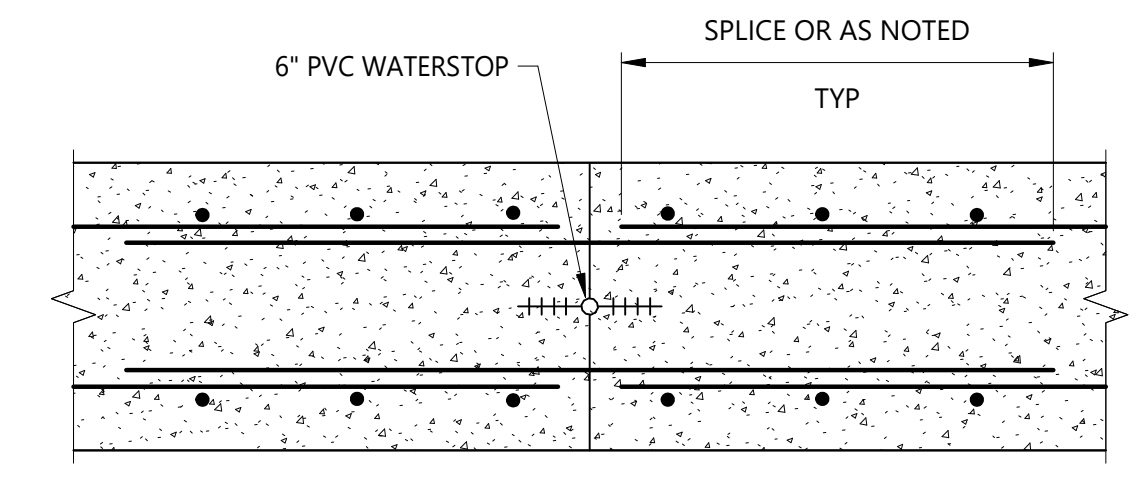

OUTLET SLAB CONSTRUCTION JOINT
NOT TO SCALE

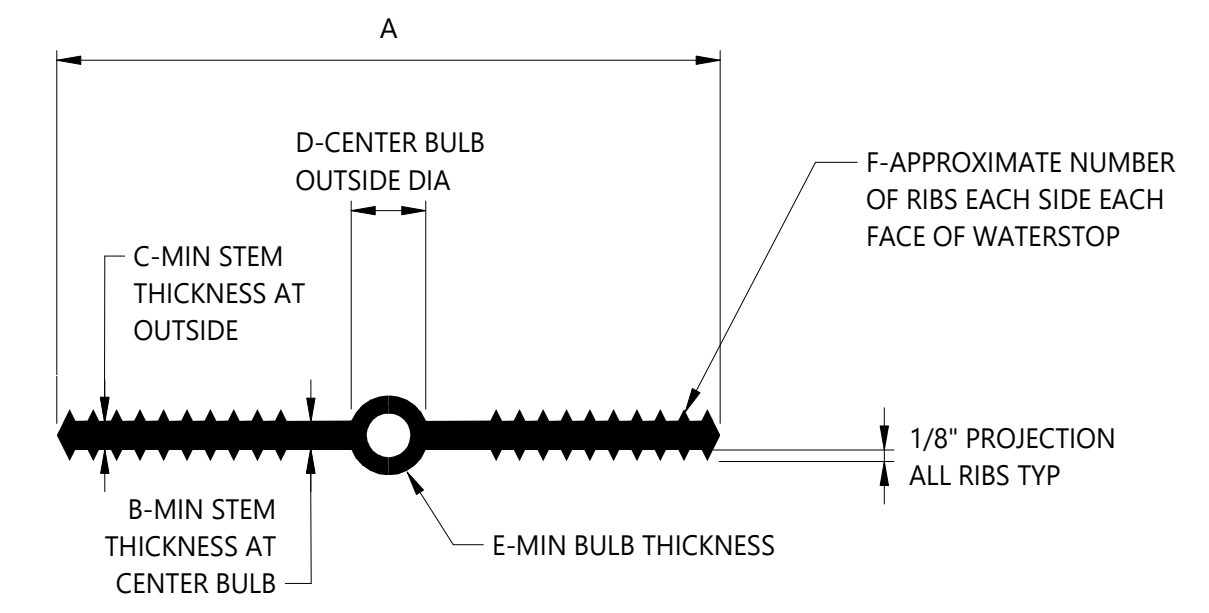

- WATERSTOP NOTES:**
- NON-ROUND CENTER BULBS SHALL HAVE A MINIMUM OUTSIDE DIMENSION OF 'D'.

SIZE	A	B	C	D	E	F
6"x3/8"	6"	3/8"	3/8"	1"	1/4"	8

PLASTIC WATERSTOP
NOT TO SCALE

- NOTES:**
1. SEE DRAWING S-100 AND S-101 FOR LEGEND, ABBREVIATIONS, AND GENERAL NOTES.

REV	REVISION DESCRIPTION	DATE	CHND	CHKD	APPR



CITY OF COLORADO SPRINGS
30 S. NEVADA AVE., SUITE 401
COLORADO SPRINGS, CO 80903
(719) 385-5980

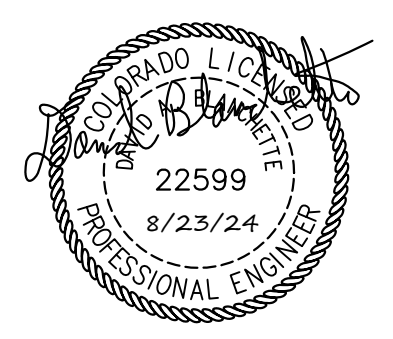

SAND CREEK DETENTION POND NO. 2

POND OUTLET STRUCTURE
CONCRETE STANDARD DETAILS

JOB NUMBER	65420975
DATE	8/23/24
DRAWING NO.	S-111
SHEET	44 of 51

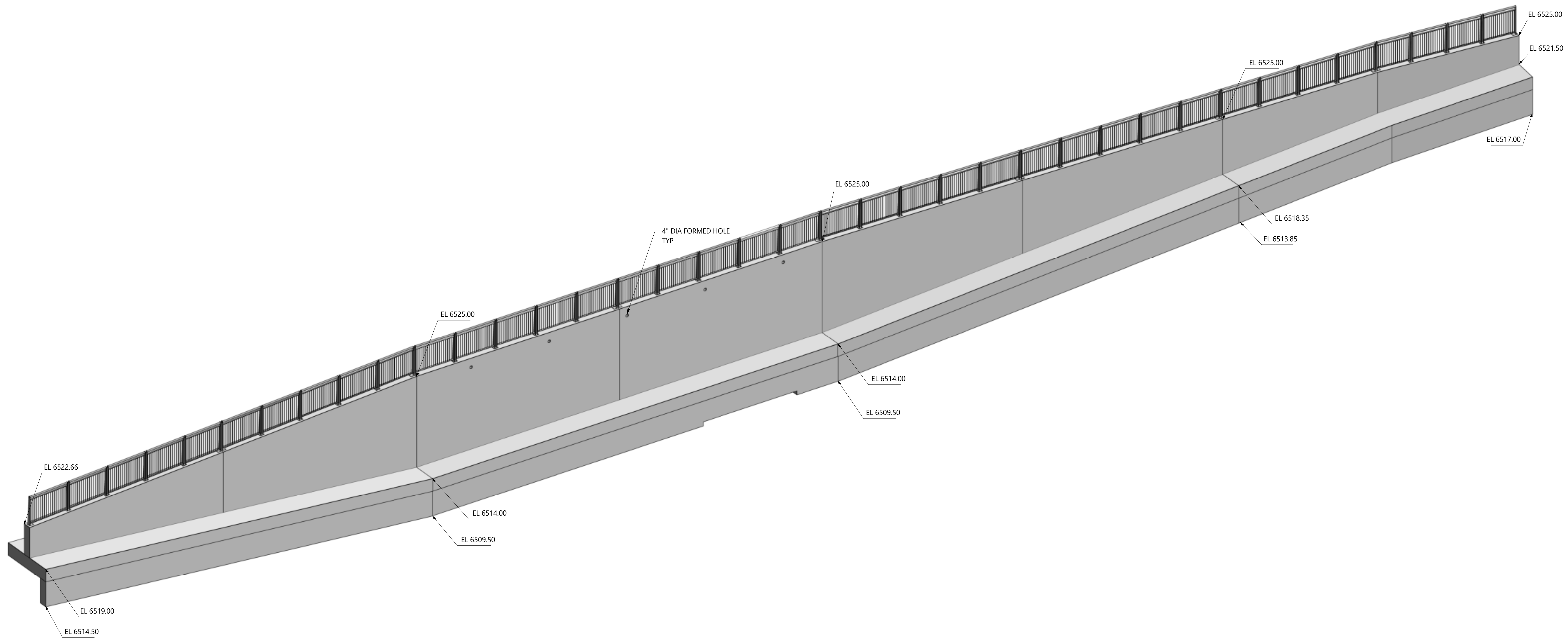

NOTES:

- SEE DRAWING S-100 AND S-101 FOR LEGEND, ABBREVIATIONS, AND GENERAL NOTES.

REV	REVISION DESCRIPTION	DATE	CHND	CHKD	APPR

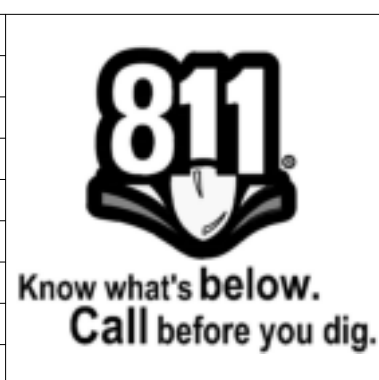

CITY OF COLORADO SPRINGS
 30 S. NEVADA AVE., SUITE 401
 COLORADO SPRINGS, CO 80903
 (719) 385-5980

SMRC
Structural Engineers Inc.
 215 S. Wadsworth Blvd., Suite 320
 Lakewood, CO 80226 ph 303.274.8656
 www.smrstructures.com

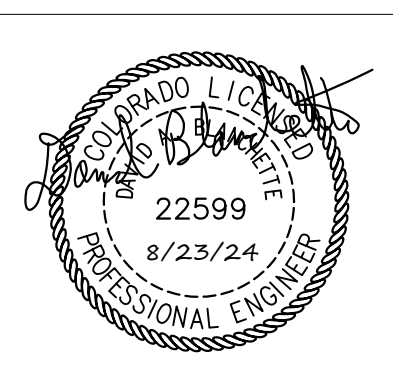

SAND CREEK DETENTION POND NO. 2

TUTT RETAINING WALL
ISOMETRIC VIEW

JOB NUMBER	65420975
DATE	8/23/24
DRAWING NO.	S-112
SHEET	45 of 51

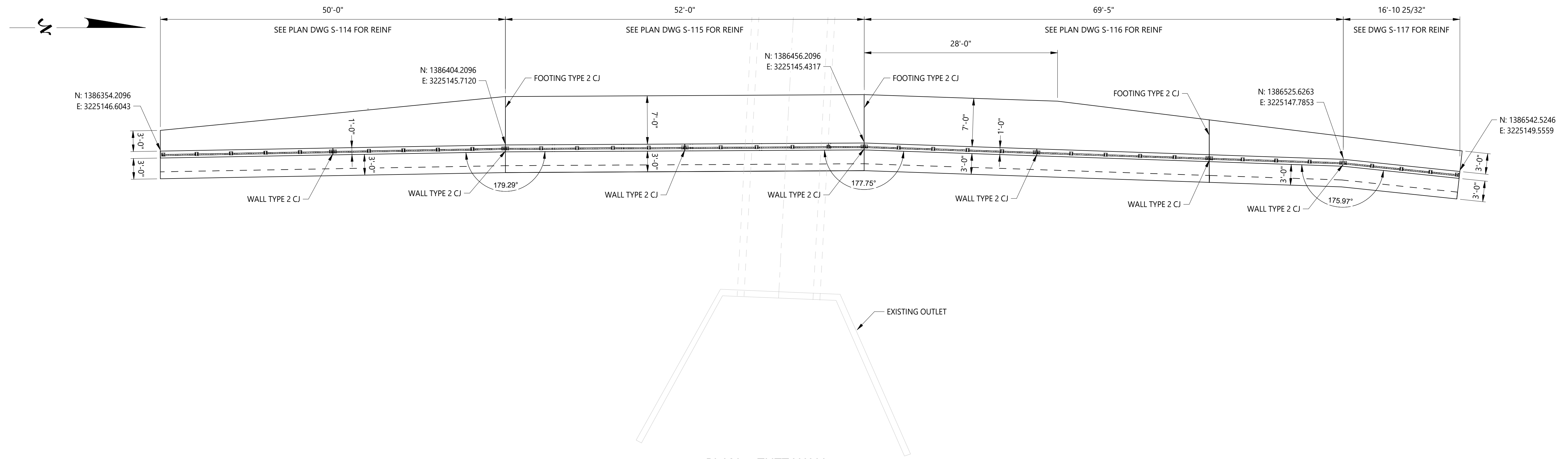

PLAN - TUTT WALL
SCALE: 1/8" = 1'-0"

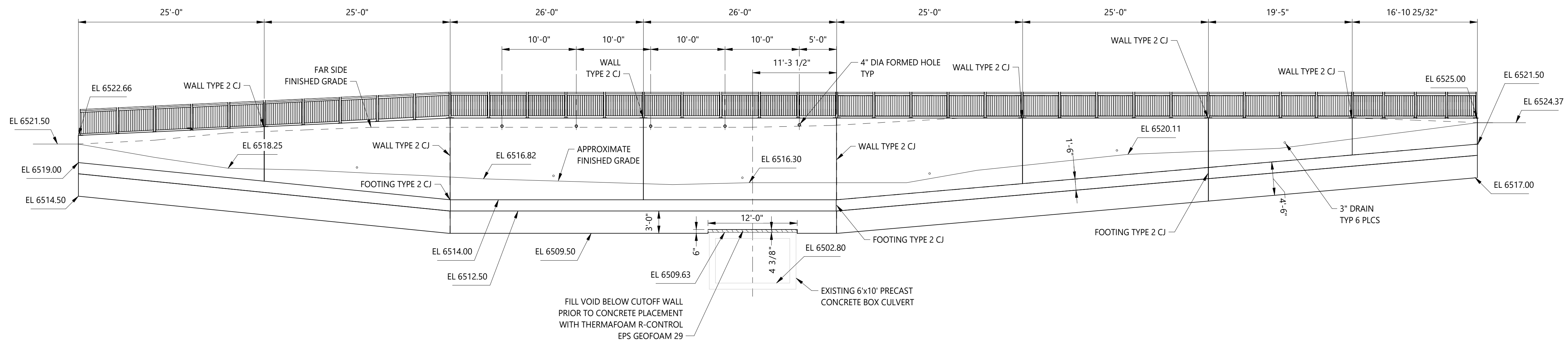

ELEVATION - TUTT WALL
SCALE: 1/8" = 1'-0"

- NOTES:
- SEE DRAWING S-100 AND S-101 FOR LEGEND, ABBREVIATIONS, AND GENERAL NOTES.
 - VERIFY LOCATION OF EXISTING BOX CULVERT AND UNDERGROUND UTILITIES INCLUDING DRAINS BEFORE DIGGING.

REV	REVISION DESCRIPTION	DATE	CHND	CHKD	APPR

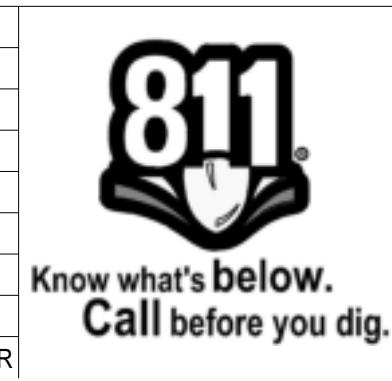

CITY OF COLORADO SPRINGS
30 S. NEVADA AVE., SUITE 401
COLORADO SPRINGS, CO 80903
(719) 385-5980

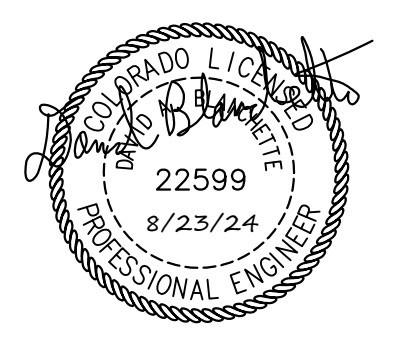

SAND CREEK DETENTION POND NO. 2
TUTT RETAINING WALL
OUTLINE PLAN AND ELEVATION

JOB NUMBER	65420975
DATE	8/23/24
DRAWING NO.	S-113
SHEET	46 of 51

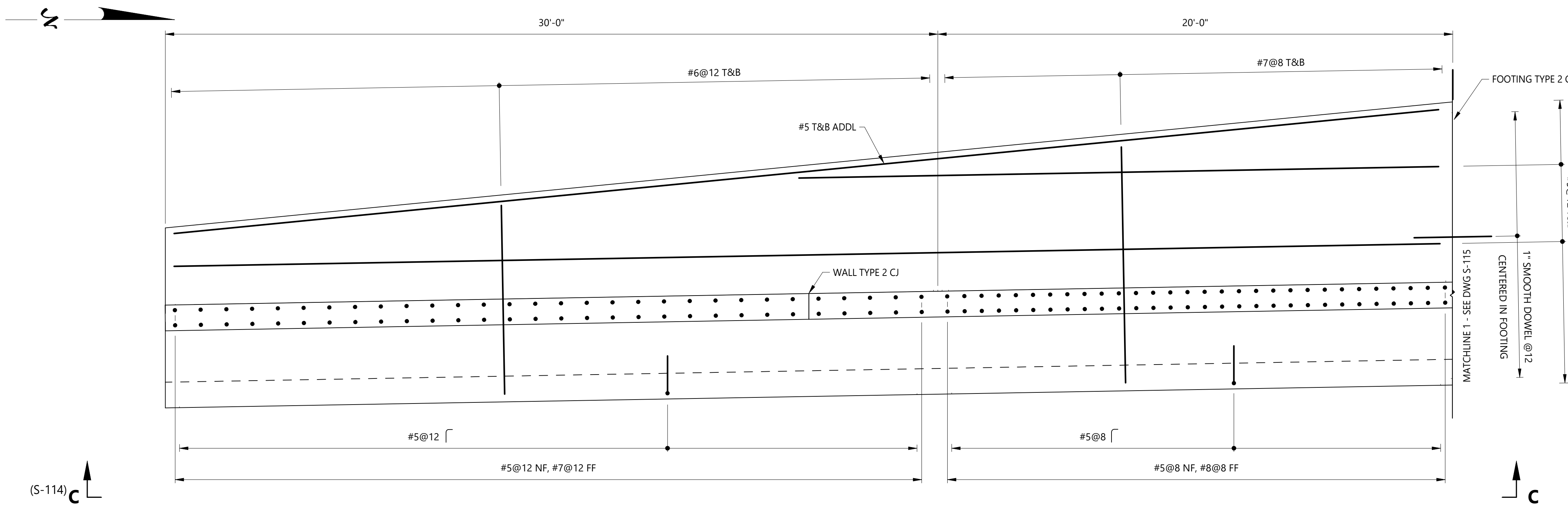

PARTIAL PLAN WALL

SCALE: 3/8" = 1'-0"

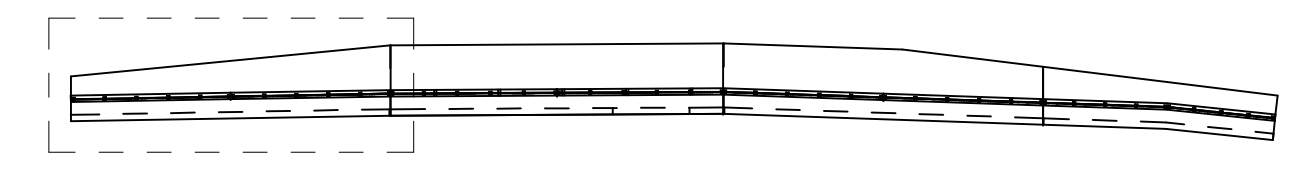

KEY PLAN
SCALE: 1" = 30'-0"

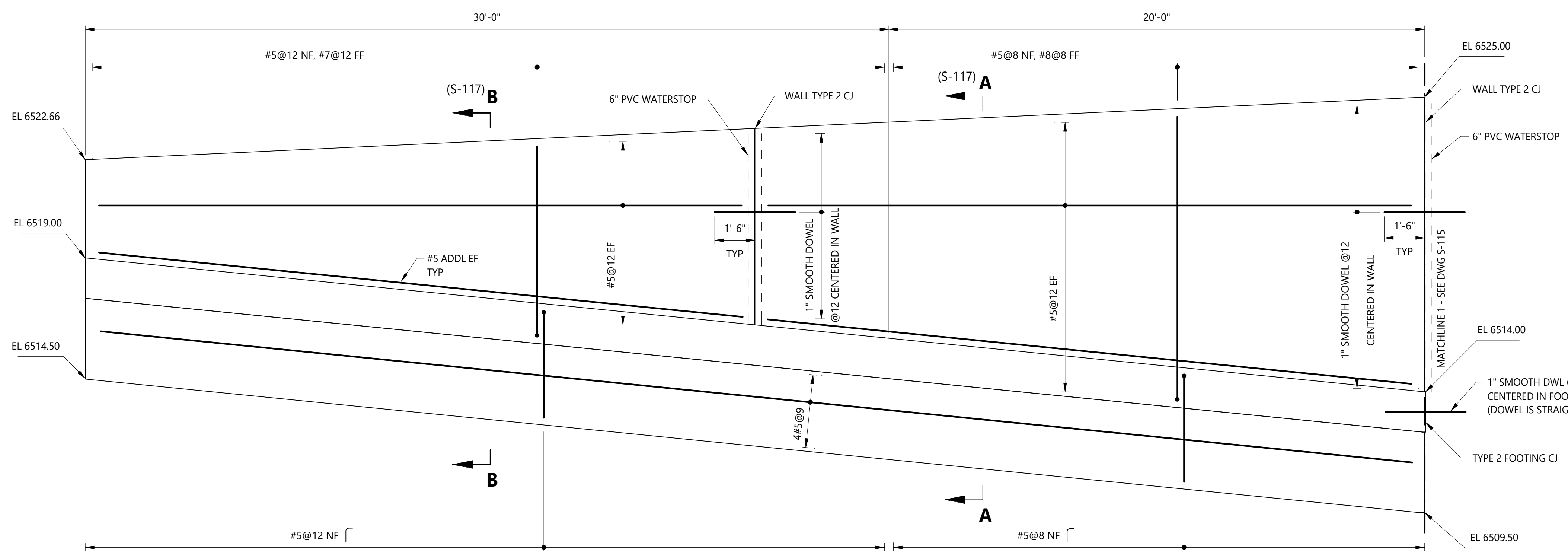

SECTION C - C (S-114)

SCALE: 3/8" = 1'-0"

NOTES:

- SEE DRAWING S-100 AND S-101 FOR LEGEND, ABBREVIATIONS, AND GENERAL NOTES.

REV	REVISION DESCRIPTION	DATE	CHND	CHKD	APPR



CITY OF COLORADO SPRINGS
30 S. NEVADA AVE., SUITE 401
COLORADO SPRINGS, CO 80903
(719) 385-5980

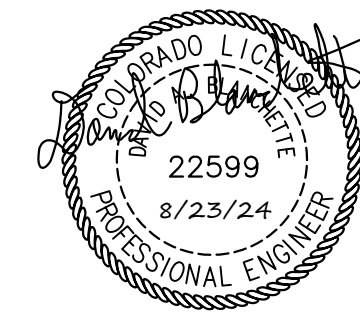

SAND CREEK DETENTION POND NO. 2

TUTT RETAINING WALL
REINFORCEMENT PLAN AND SECTION

JOB NUMBER	65420975
DATE	8/23/24
DRAWING NO.	S-114
SHEET	47 of 51

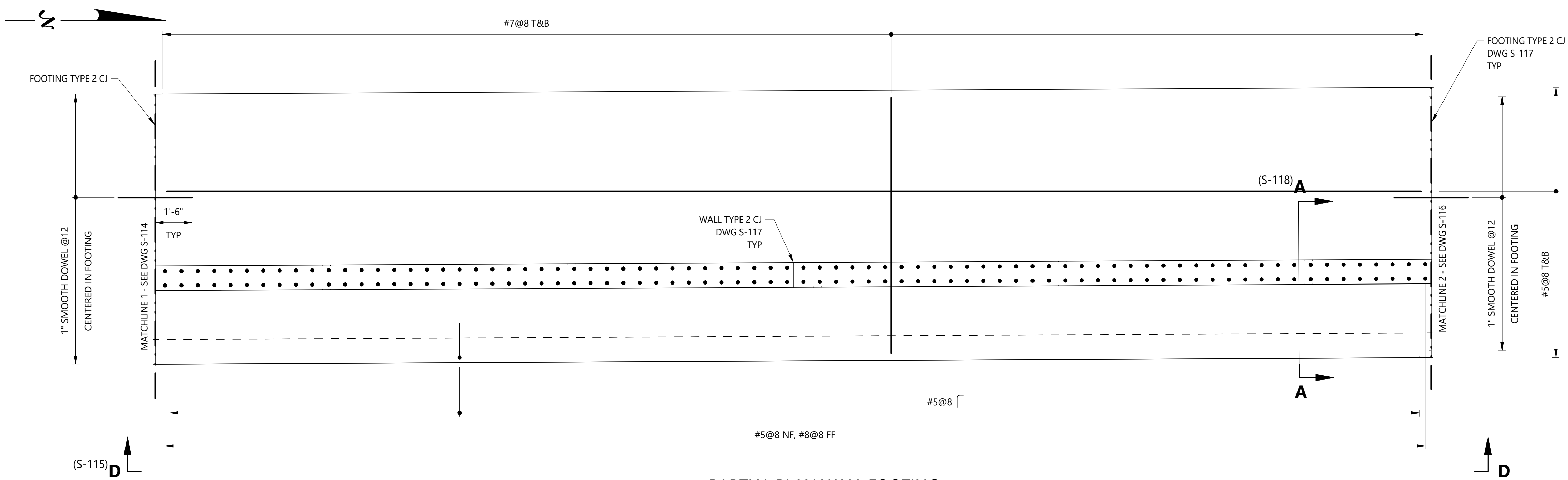

PARTIAL PLAN WALL FOOTING
SCALE: 3/8" = 1'-0"

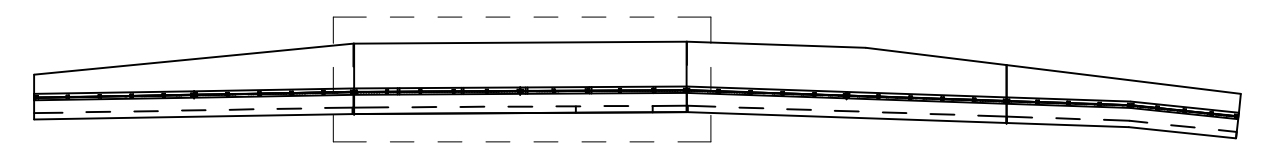

KEY PLAN
SCALE: 1" = 30'-0"

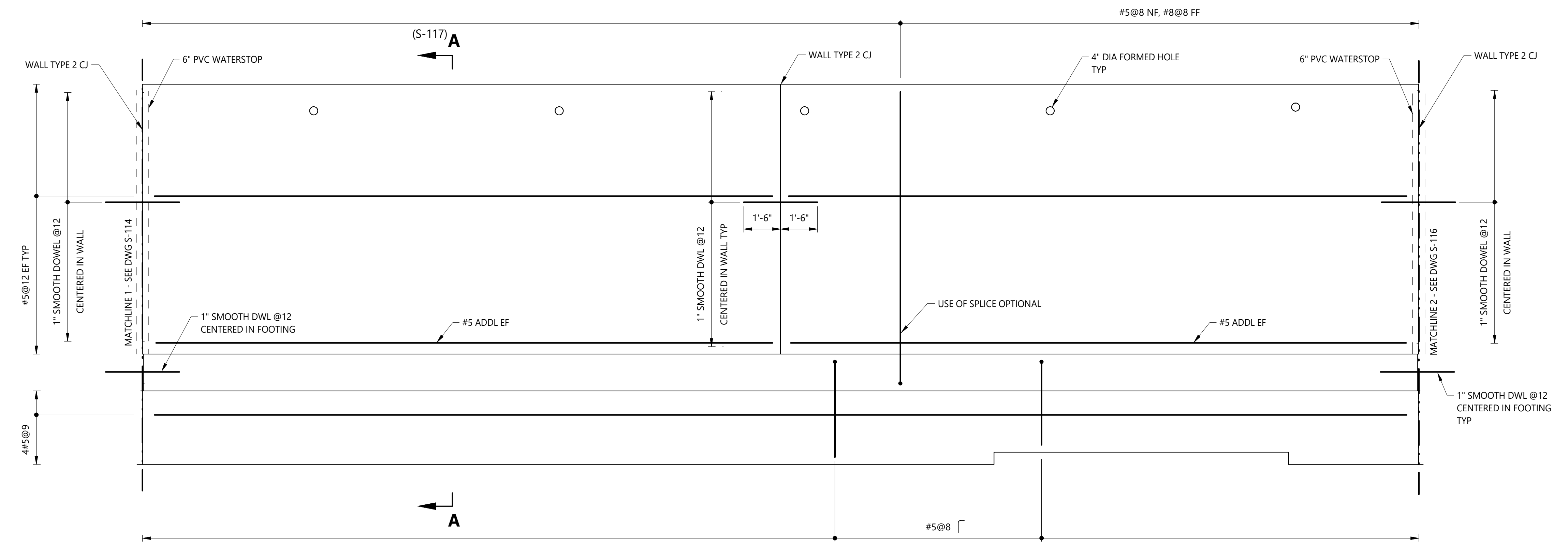

SECTION D - D (S-115)
SCALE: 3/8" = 1'-0"

REV	REVISION DESCRIPTION	DATE	CHND	CHKD	APPR



CITY OF COLORADO SPRINGS
30 S. NEVADA AVE., SUITE 401
COLORADO SPRINGS, CO 80903
(719) 385-5980

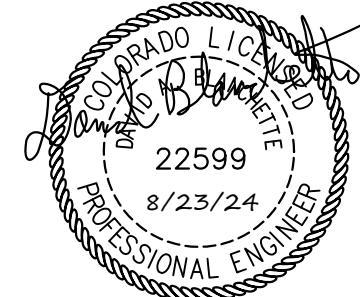

SAND CREEK DETENTION POND NO. 2

TUTT RETAINING WALL
REINFORCEMENT PLAN AND SECTION

JOB NUMBER	65420975
DATE	8/23/24
DRAWING NO.	S-115
SHEET	48 of 51

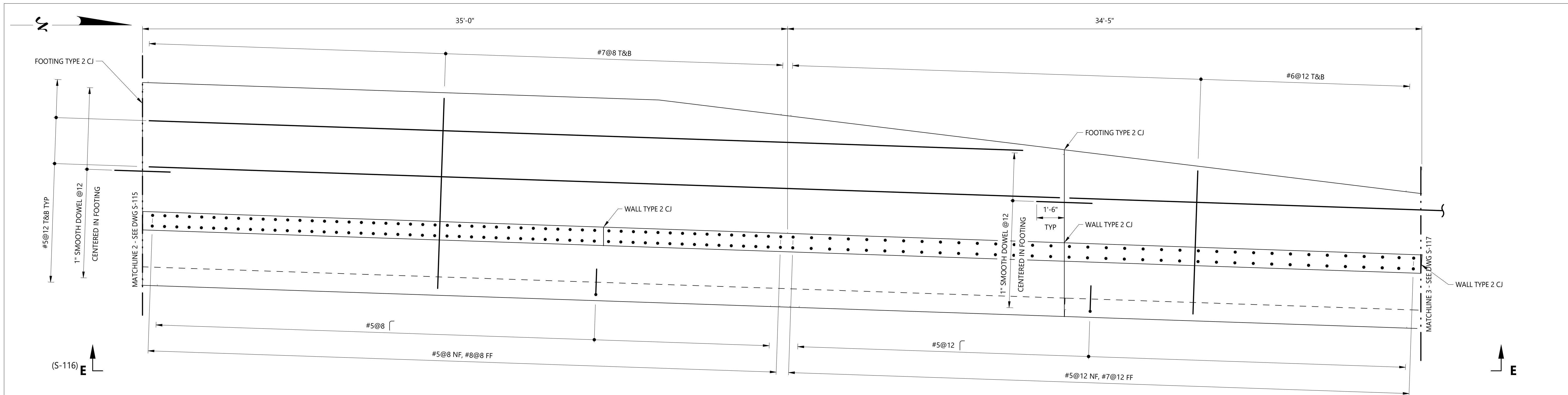

PARTIAL PLAN WALL FOOTING
SCALE: 3/8" = 1'-0"

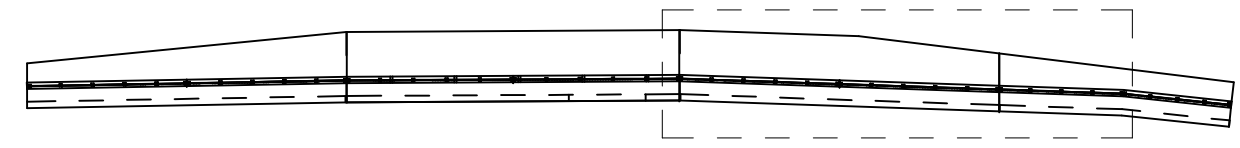

KEY PLAN
SCALE: 1" = 30'-0"

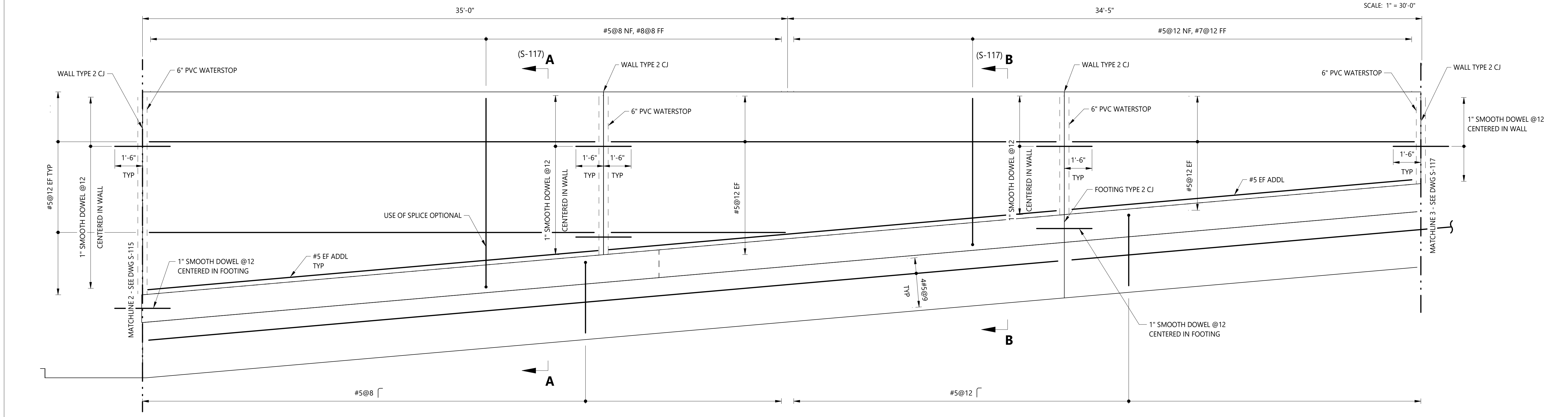

SECTION E - E (S-116)
SCALE: 3/8" = 1'-0"

REV	REVISION DESCRIPTION	DATE	CHND	CHKD	APPR



CITY OF COLORADO SPRINGS
30 S. NEVADA AVE., SUITE 401
COLORADO SPRINGS, CO 80903
(719) 385-5980

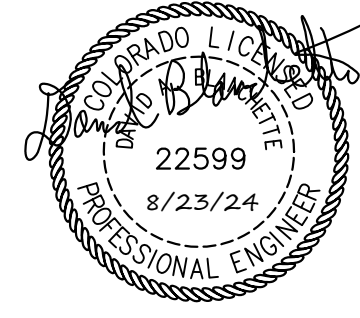

SAND CREEK DETENTION POND NO. 2
TUTT RETAINING WALL
REINFORCEMENT PLAN AND SECTION

JOB NUMBER	65420975
DATE	8/23/24
DRAWING NO.	S-116
SHEET	49 of 51

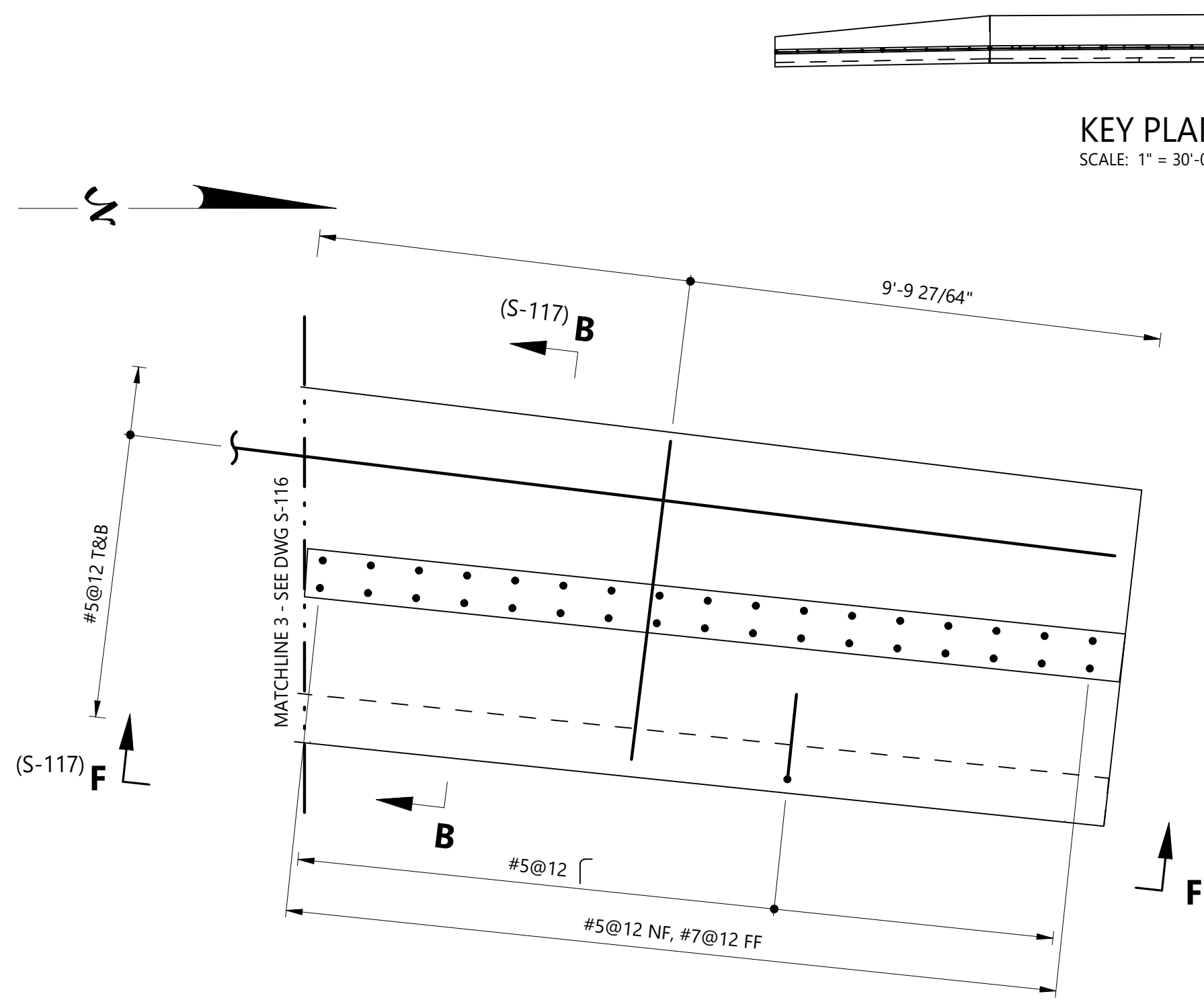

PARTIAL PLAN WALL FOOTING
SCALE: 3/8" = 1'-0"

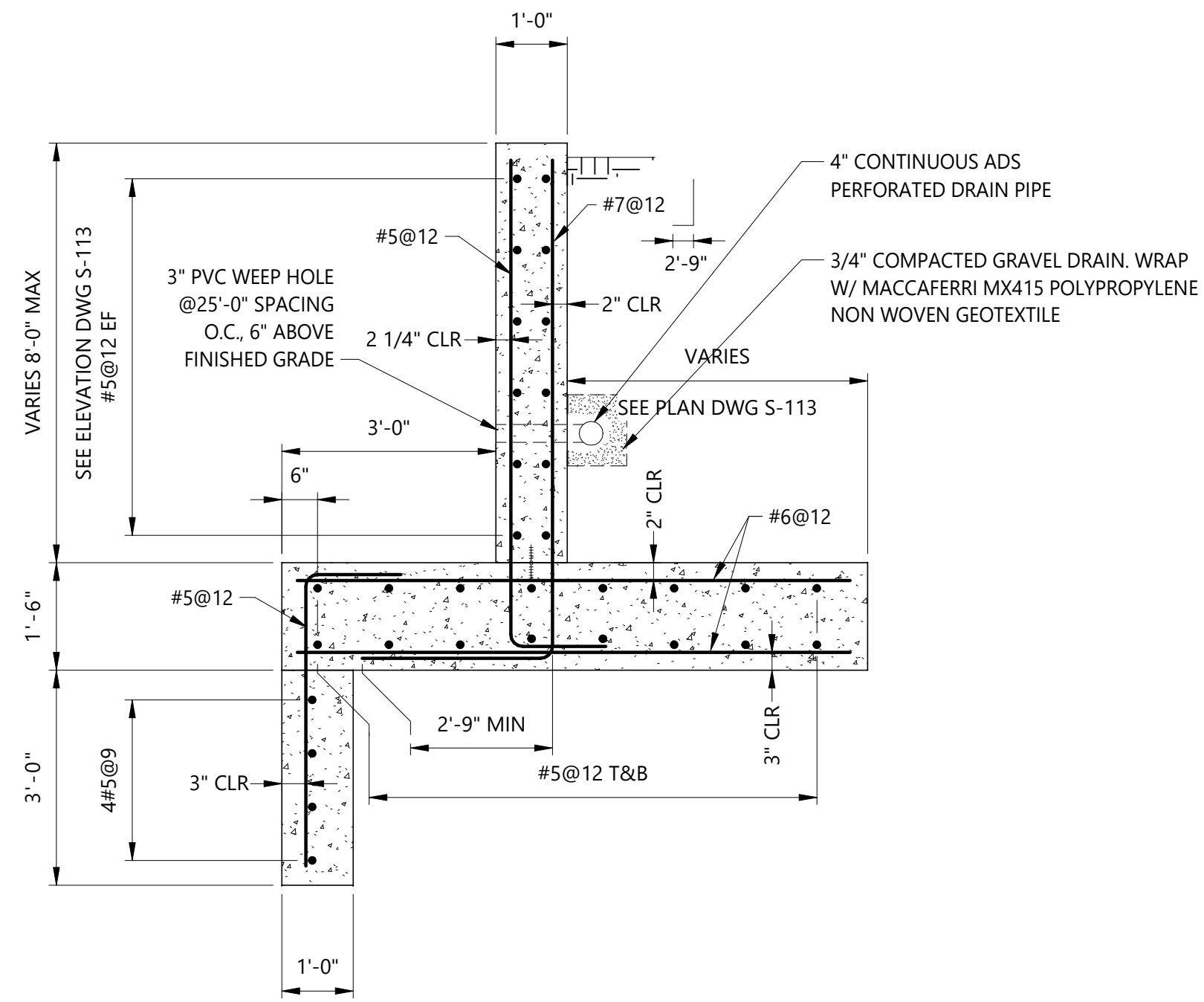

SECTION B-B (S-114, 116, 117)
SCALE: 1/2" = 1'-0"

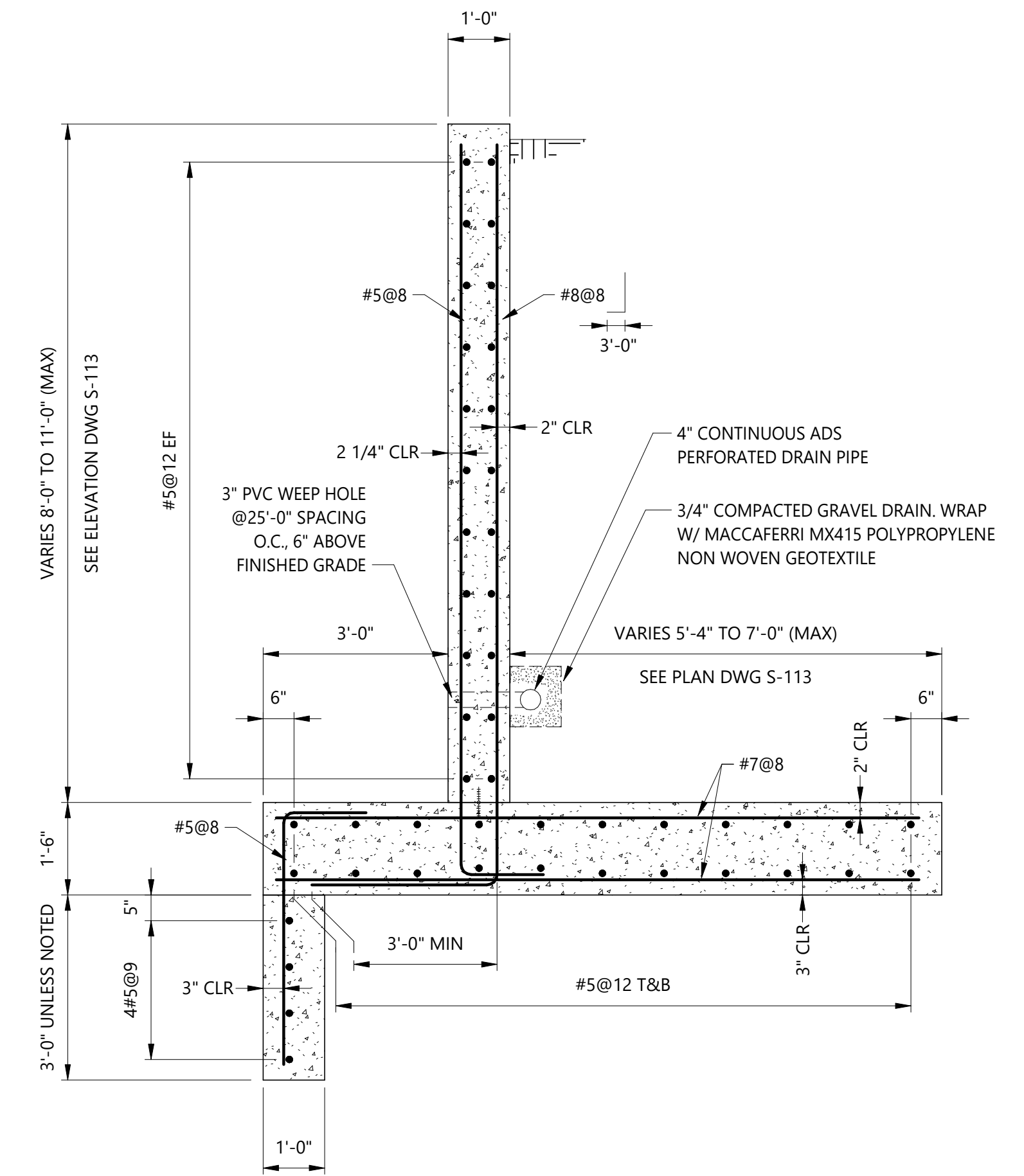

SECTION A-A (S-114, 115, 116)
SCALE: 1/2" = 1'-0"

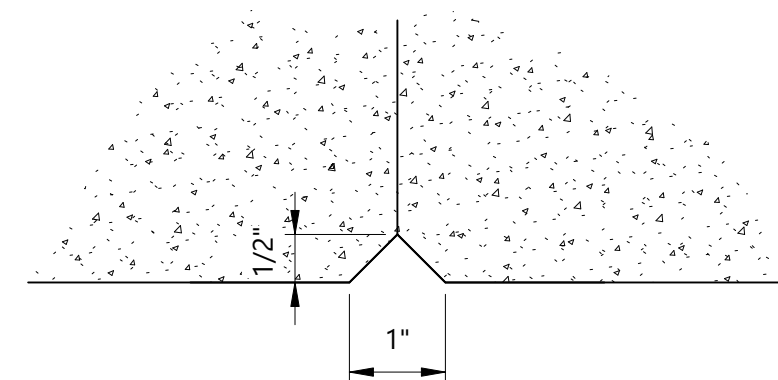

DETAIL 2 - VEE GROOVE
SCALE: 6" = 1'-0"

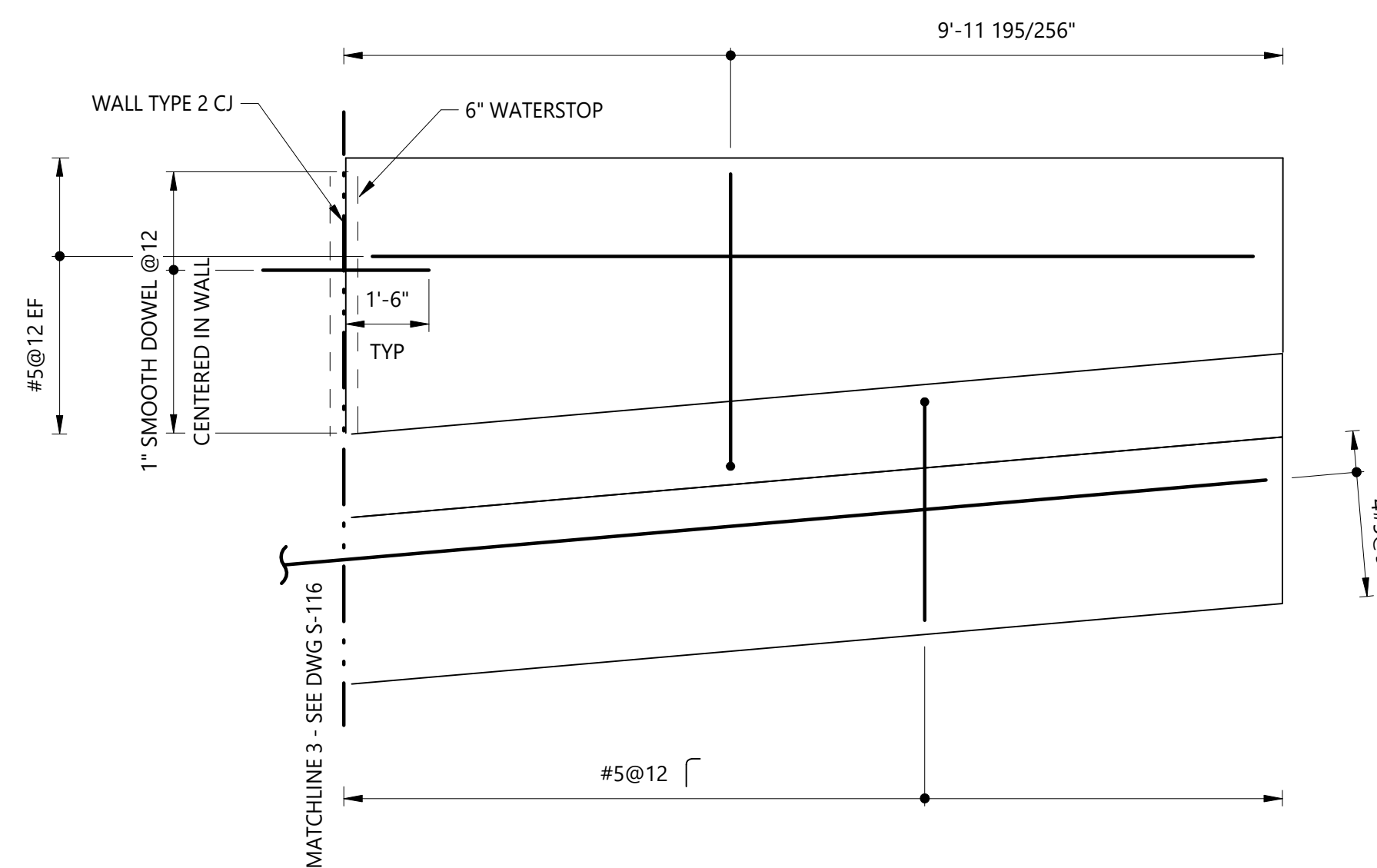

SECTION F - F (S-117)
SCALE: 3/8" = 1'-0"

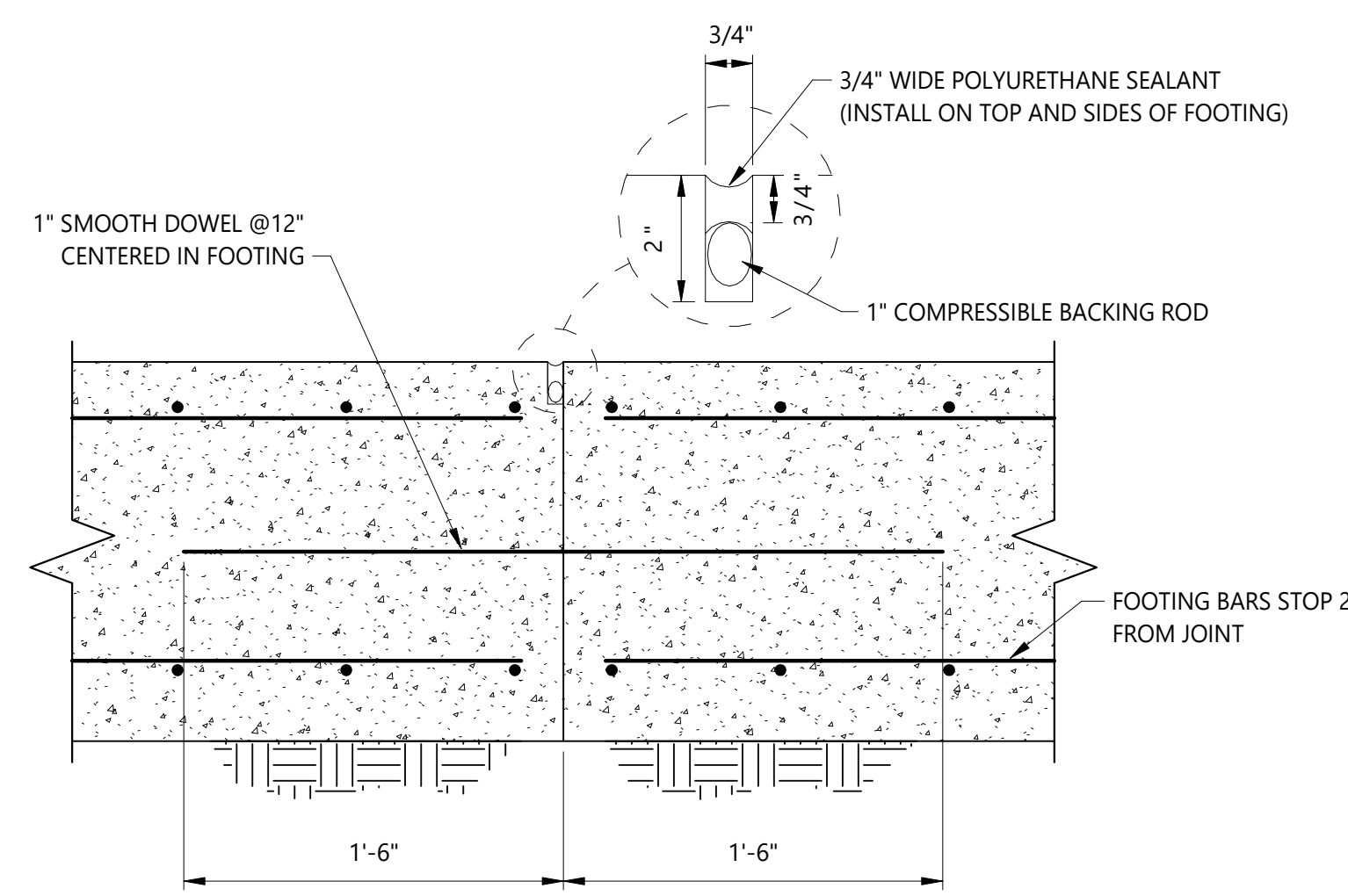

TYPE 2 FOOTING CONSTRUCTION JOINT
SCALE: 1 1/2" = 1'-0"

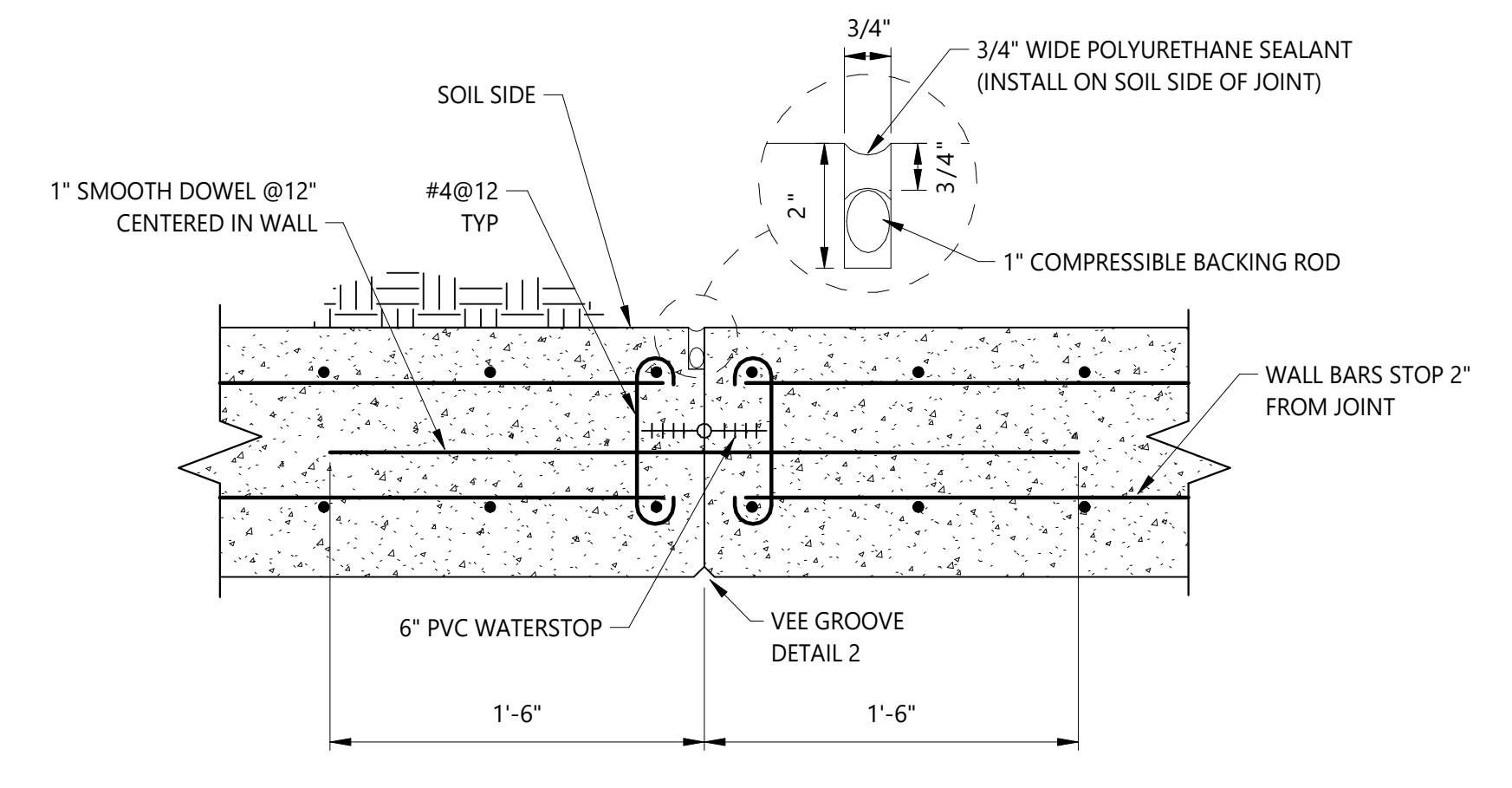

TYPE 2 VERTICAL WALL CONSTRUCTION JOINT
SCALE: 1 1/2" = 1'-0"

REV	REVISION DESCRIPTION	DATE	CHND	CHKD	APPR

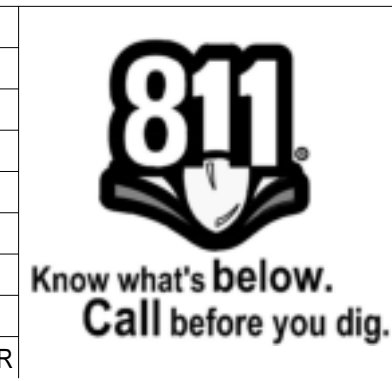

CITY OF COLORADO SPRINGS
30 S. NEVADA AVE., SUITE 401
COLORADO SPRINGS, CO 80903
(719) 385-5980

SMRC
Structural Engineers Inc.
215 S. Wadsworth Blvd., Suite 320
Lakewood, CO 80226 ph 303.274.8656
www.smrstructures.com

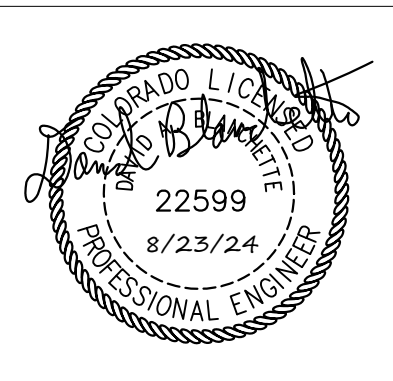

SAND CREEK DETENTION POND NO. 2

TUTT RETAINING WALL
REINFORCEMENT PLAN AND SECTIONS

JOB NUMBER	65420975
DATE	8/23/24
DRAWING NO.	S-117
SHEET	50 of 51

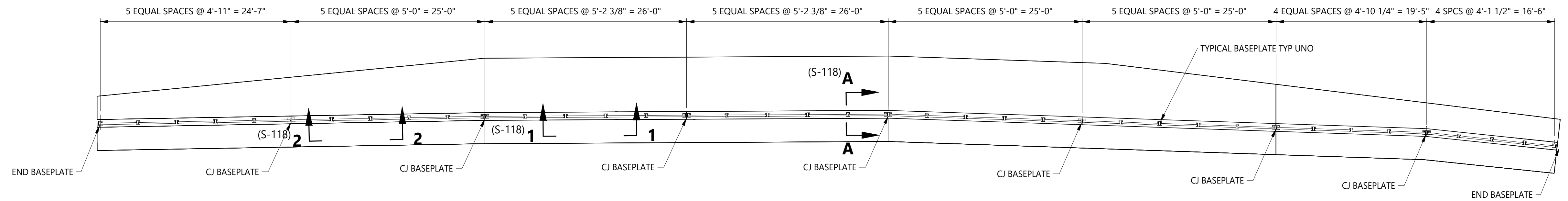

TUTT WALL BASEPLATE PLAN
SCALE: 1/8" = 1'-0"

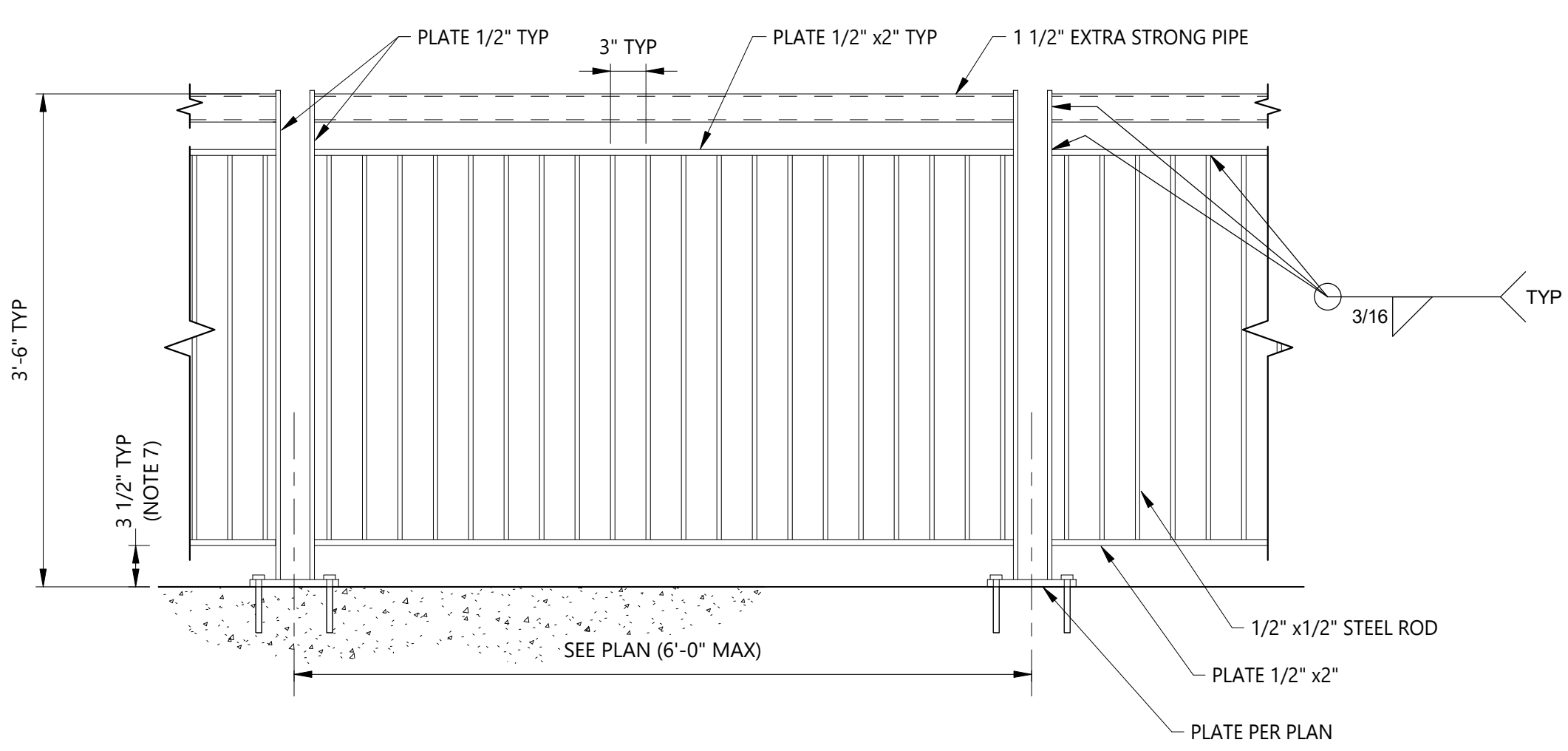

DETAIL 1 TYPICAL HORIZONTAL HANDRAIL
SCALE: 1" = 1'-0"

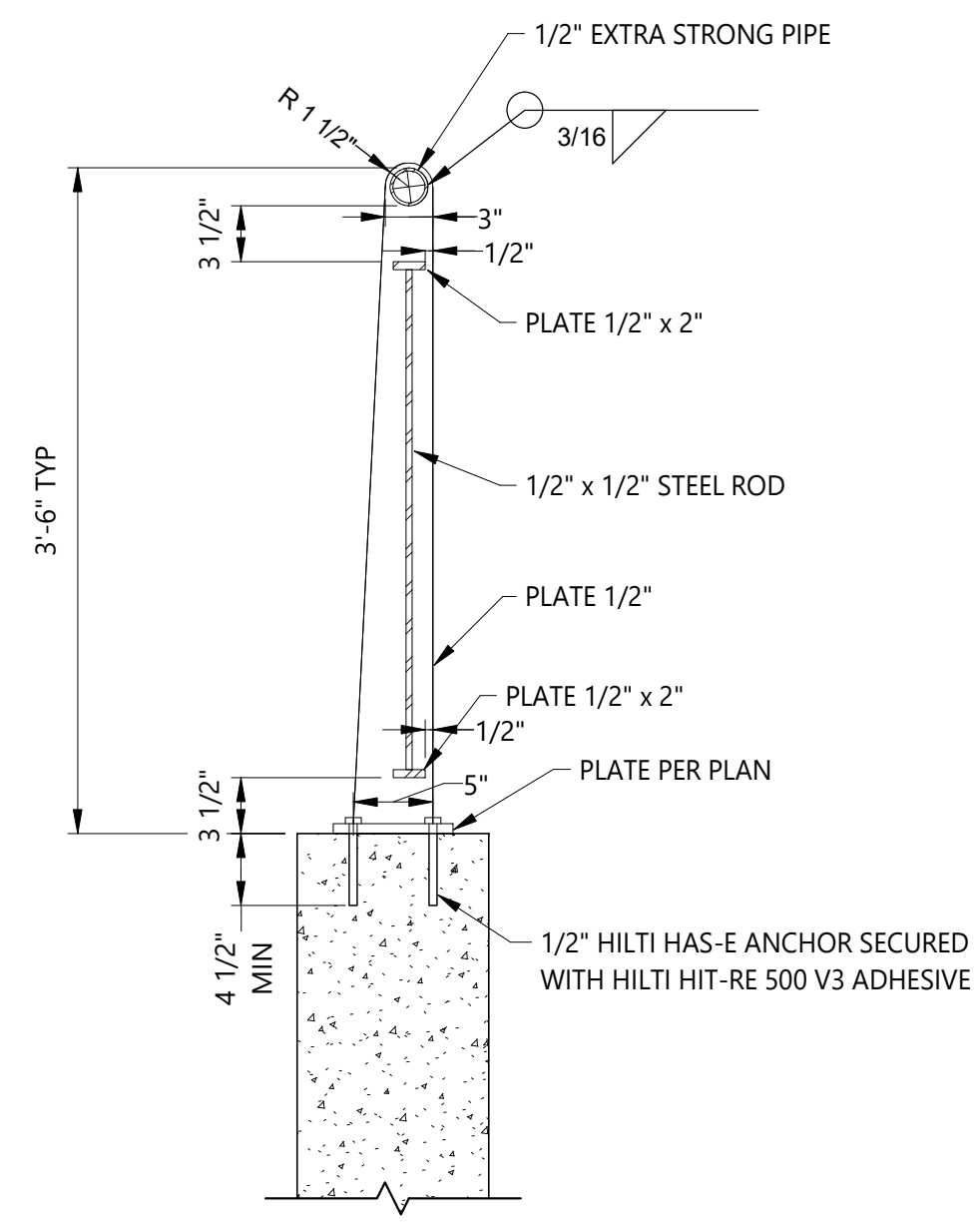

SECTION A - A (S-115)
SCALE: 1" = 1'-0"

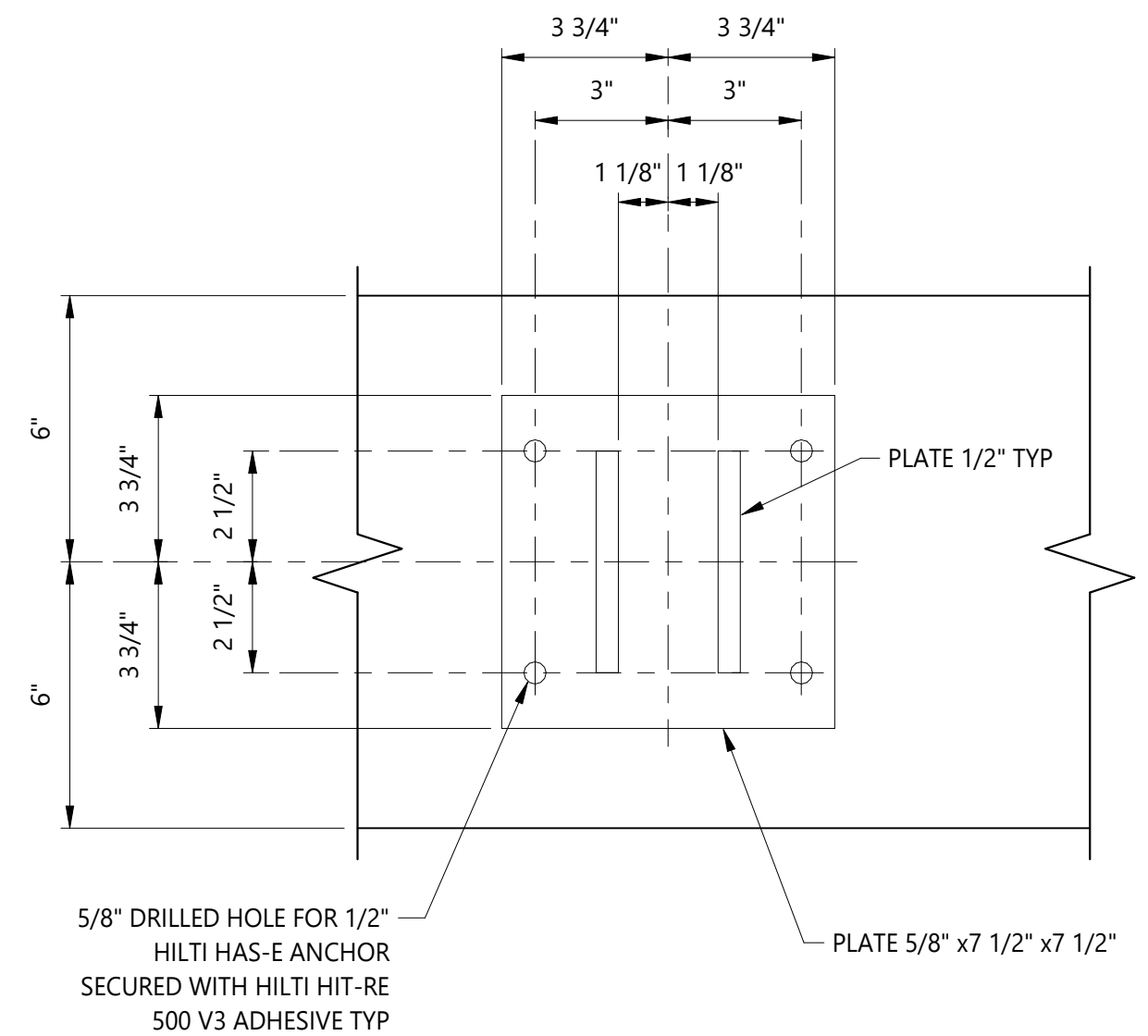

TYPICAL BASEPLATE
SCALE: 3" = 1'-0"

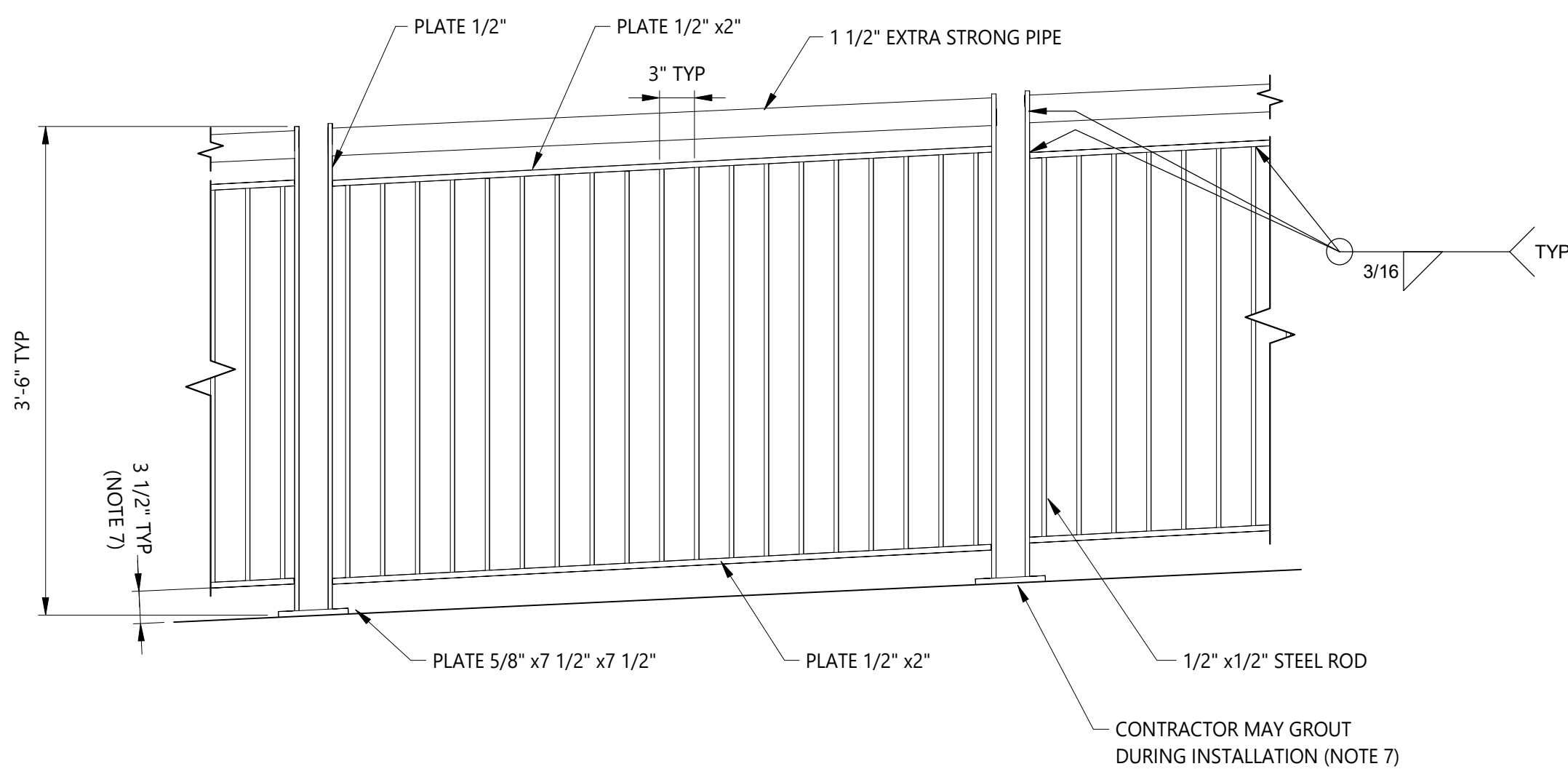

DETAIL 2 TYPICAL SLOPING HANDRAIL
SCALE: 1" = 1'-0"

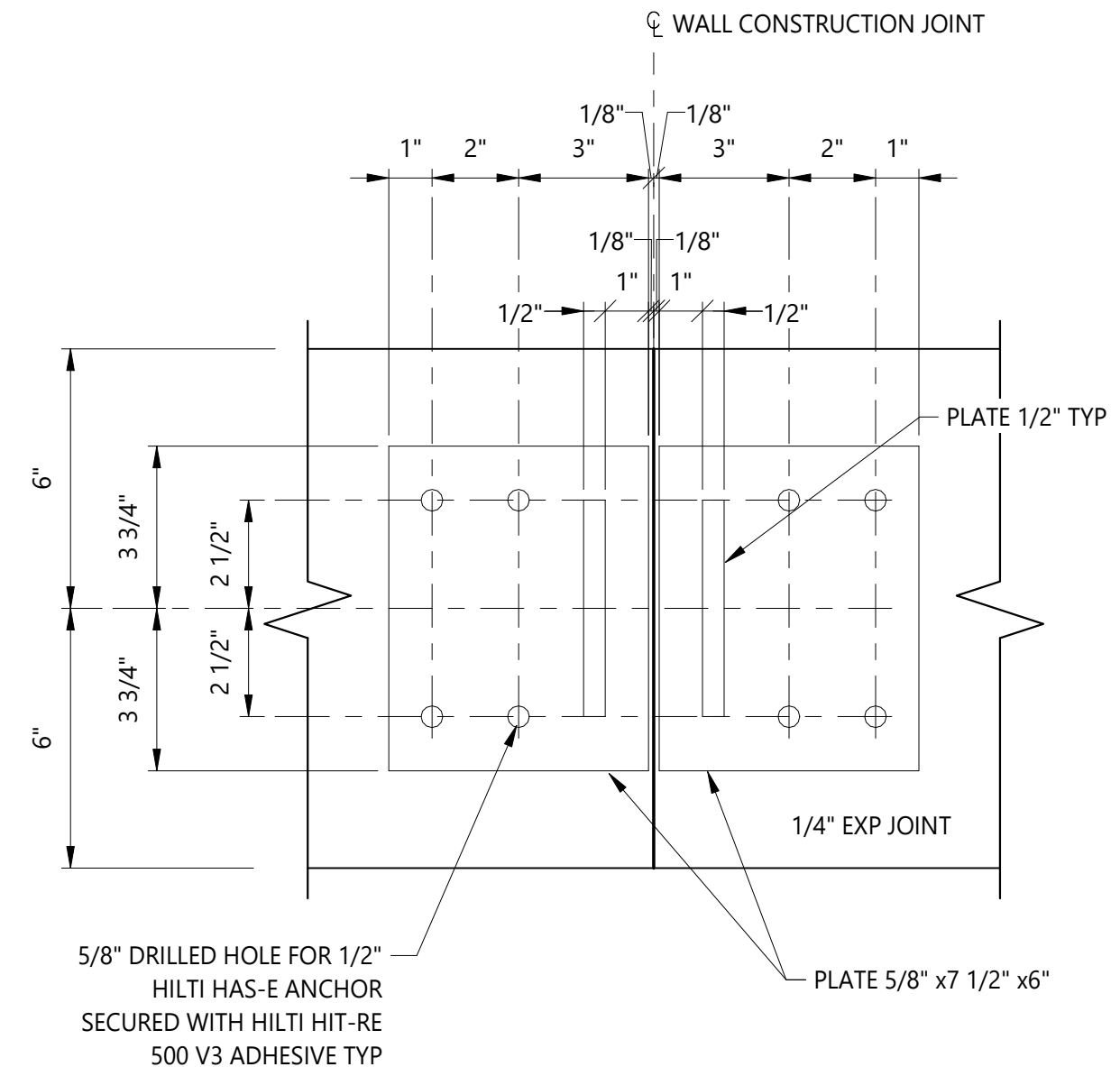

CJ BASEPLATE
SCALE: 3" = 1'-0"

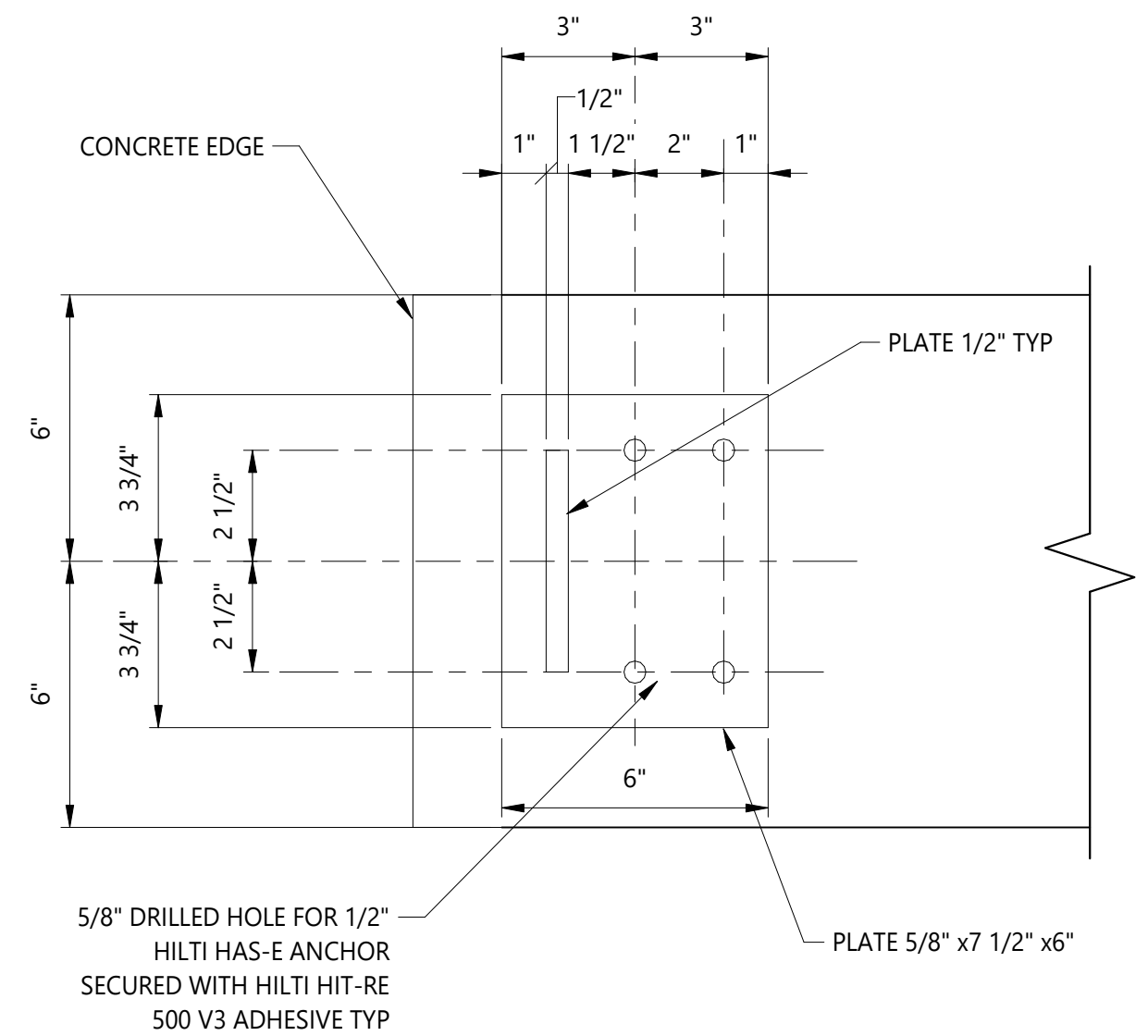

END BASEPLATE
SCALE: 3" = 1'-0"

- TYPICAL HANDRAIL NOTES:**
1. ALL RAILING COMPONENTS TO BE PAINTED AS DIRECTED BY ARCHITECT.
 2. CONTRACTOR TO PROVIDE SHOP DRAWINGS INCLUDING WELD INFORMATION.
 3. CONTRACTOR SHALL FIELD MEASURE HEAD WALLS AND WING WALLS TO ENSURE PROPER FIT OF RAILING.
 4. POSTS AND PICKETS SHALL BE PLUMB ON RAILING SECTIONS.
 5. INSTALL SINGLE POST AT END OF RAILING.
 6. HANDRAIL POST SPACING AT TUTT WALL SHALL BE EQUIDISTANCE BETWEEN CONSTRUCTION JOINTS AND TO BE FIELD VERIFIED.
 7. RAIL GAP TO TOP OF CONCRETE TO BE 4" MAX.

REV	REVISION DESCRIPTION	DATE	CHND	CHKD	APPR



CITY OF COLORADO SPRINGS
30 S. NEVADA AVE., SUITE 401
COLORADO SPRINGS, CO 80903
(719) 385-5980

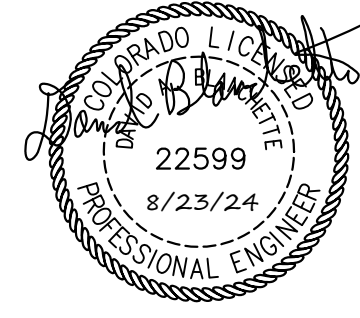

SAND CREEK DETENTION POND NO. 2

TUTT RETAINING WALL
HANDRAIL STEEL DETAILS

JOB NUMBER	65420975
DATE	8/23/24
DRAWING NO.	S-118
SHEET	51 of 51

APPENDIX B- GEOTECHNICAL EVALUATION REPORT



Custom Soil Resource Report for El Paso County Area, Colorado

Sand Creek Detention Pond 2



Preface

Soil surveys contain information that affects land use planning in survey areas. They highlight soil limitations that affect various land uses and provide information about the properties of the soils in the survey areas. Soil surveys are designed for many different users, including farmers, ranchers, foresters, agronomists, urban planners, community officials, engineers, developers, builders, and home buyers. Also, conservationists, teachers, students, and specialists in recreation, waste disposal, and pollution control can use the surveys to help them understand, protect, or enhance the environment.

Various land use regulations of Federal, State, and local governments may impose special restrictions on land use or land treatment. Soil surveys identify soil properties that are used in making various land use or land treatment decisions. The information is intended to help the land users identify and reduce the effects of soil limitations on various land uses. The landowner or user is responsible for identifying and complying with existing laws and regulations.

Although soil survey information can be used for general farm, local, and wider area planning, onsite investigation is needed to supplement this information in some cases. Examples include soil quality assessments (<http://www.nrcs.usda.gov/wps/portal/nrcs/main/soils/health/>) and certain conservation and engineering applications. For more detailed information, contact your local USDA Service Center (<https://offices.sc.egov.usda.gov/locator/app?agency=nrcs>) or your NRCS State Soil Scientist (http://www.nrcs.usda.gov/wps/portal/nrcs/detail/soils/contactus/?cid=nrcs142p2_053951).

Great differences in soil properties can occur within short distances. Some soils are seasonally wet or subject to flooding. Some are too unstable to be used as a foundation for buildings or roads. Clayey or wet soils are poorly suited to use as septic tank absorption fields. A high water table makes a soil poorly suited to basements or underground installations.

The National Cooperative Soil Survey is a joint effort of the United States Department of Agriculture and other Federal agencies, State agencies including the Agricultural Experiment Stations, and local agencies. The Natural Resources Conservation Service (NRCS) has leadership for the Federal part of the National Cooperative Soil Survey.

Information about soils is updated periodically. Updated information is available through the NRCS Web Soil Survey, the site for official soil survey information.

The U.S. Department of Agriculture (USDA) prohibits discrimination in all its programs and activities on the basis of race, color, national origin, age, disability, and where applicable, sex, marital status, familial status, parental status, religion, sexual orientation, genetic information, political beliefs, reprisal, or because all or a part of an individual's income is derived from any public assistance program. (Not all prohibited bases apply to all programs.) Persons with disabilities who require

alternative means for communication of program information (Braille, large print, audiotape, etc.) should contact USDA's TARGET Center at (202) 720-2600 (voice and TDD). To file a complaint of discrimination, write to USDA, Director, Office of Civil Rights, 1400 Independence Avenue, S.W., Washington, D.C. 20250-9410 or call (800) 795-3272 (voice) or (202) 720-6382 (TDD). USDA is an equal opportunity provider and employer.

Contents

Preface	2
How Soil Surveys Are Made	5
Soil Map	8
Soil Map.....	9
Legend.....	10
Map Unit Legend.....	11
Map Unit Descriptions.....	11
El Paso County Area, Colorado.....	13
10—Blendon sandy loam, 0 to 3 percent slopes.....	13
28—Ellicott loamy coarse sand, 0 to 5 percent slopes.....	14
85—Stapleton-Bernal sandy loams, 3 to 20 percent slopes.....	15
97—Truckton sandy loam, 3 to 9 percent slopes.....	17
References	19

How Soil Surveys Are Made

Soil surveys are made to provide information about the soils and miscellaneous areas in a specific area. They include a description of the soils and miscellaneous areas and their location on the landscape and tables that show soil properties and limitations affecting various uses. Soil scientists observed the steepness, length, and shape of the slopes; the general pattern of drainage; the kinds of crops and native plants; and the kinds of bedrock. They observed and described many soil profiles. A soil profile is the sequence of natural layers, or horizons, in a soil. The profile extends from the surface down into the unconsolidated material in which the soil formed or from the surface down to bedrock. The unconsolidated material is devoid of roots and other living organisms and has not been changed by other biological activity.

Currently, soils are mapped according to the boundaries of major land resource areas (MLRAs). MLRAs are geographically associated land resource units that share common characteristics related to physiography, geology, climate, water resources, soils, biological resources, and land uses (USDA, 2006). Soil survey areas typically consist of parts of one or more MLRA.

The soils and miscellaneous areas in a survey area occur in an orderly pattern that is related to the geology, landforms, relief, climate, and natural vegetation of the area. Each kind of soil and miscellaneous area is associated with a particular kind of landform or with a segment of the landform. By observing the soils and miscellaneous areas in the survey area and relating their position to specific segments of the landform, a soil scientist develops a concept, or model, of how they were formed. Thus, during mapping, this model enables the soil scientist to predict with a considerable degree of accuracy the kind of soil or miscellaneous area at a specific location on the landscape.

Commonly, individual soils on the landscape merge into one another as their characteristics gradually change. To construct an accurate soil map, however, soil scientists must determine the boundaries between the soils. They can observe only a limited number of soil profiles. Nevertheless, these observations, supplemented by an understanding of the soil-vegetation-landscape relationship, are sufficient to verify predictions of the kinds of soil in an area and to determine the boundaries.

Soil scientists recorded the characteristics of the soil profiles that they studied. They noted soil color, texture, size and shape of soil aggregates, kind and amount of rock fragments, distribution of plant roots, reaction, and other features that enable them to identify soils. After describing the soils in the survey area and determining their properties, the soil scientists assigned the soils to taxonomic classes (units). Taxonomic classes are concepts. Each taxonomic class has a set of soil characteristics with precisely defined limits. The classes are used as a basis for comparison to classify soils systematically. Soil taxonomy, the system of taxonomic classification used in the United States, is based mainly on the kind and character of soil properties and the arrangement of horizons within the profile. After the soil

scientists classified and named the soils in the survey area, they compared the individual soils with similar soils in the same taxonomic class in other areas so that they could confirm data and assemble additional data based on experience and research.

The objective of soil mapping is not to delineate pure map unit components; the objective is to separate the landscape into landforms or landform segments that have similar use and management requirements. Each map unit is defined by a unique combination of soil components and/or miscellaneous areas in predictable proportions. Some components may be highly contrasting to the other components of the map unit. The presence of minor components in a map unit in no way diminishes the usefulness or accuracy of the data. The delineation of such landforms and landform segments on the map provides sufficient information for the development of resource plans. If intensive use of small areas is planned, onsite investigation is needed to define and locate the soils and miscellaneous areas.

Soil scientists make many field observations in the process of producing a soil map. The frequency of observation is dependent upon several factors, including scale of mapping, intensity of mapping, design of map units, complexity of the landscape, and experience of the soil scientist. Observations are made to test and refine the soil-landscape model and predictions and to verify the classification of the soils at specific locations. Once the soil-landscape model is refined, a significantly smaller number of measurements of individual soil properties are made and recorded. These measurements may include field measurements, such as those for color, depth to bedrock, and texture, and laboratory measurements, such as those for content of sand, silt, clay, salt, and other components. Properties of each soil typically vary from one point to another across the landscape.

Observations for map unit components are aggregated to develop ranges of characteristics for the components. The aggregated values are presented. Direct measurements do not exist for every property presented for every map unit component. Values for some properties are estimated from combinations of other properties.

While a soil survey is in progress, samples of some of the soils in the area generally are collected for laboratory analyses and for engineering tests. Soil scientists interpret the data from these analyses and tests as well as the field-observed characteristics and the soil properties to determine the expected behavior of the soils under different uses. Interpretations for all of the soils are field tested through observation of the soils in different uses and under different levels of management. Some interpretations are modified to fit local conditions, and some new interpretations are developed to meet local needs. Data are assembled from other sources, such as research information, production records, and field experience of specialists. For example, data on crop yields under defined levels of management are assembled from farm records and from field or plot experiments on the same kinds of soil.

Predictions about soil behavior are based not only on soil properties but also on such variables as climate and biological activity. Soil conditions are predictable over long periods of time, but they are not predictable from year to year. For example, soil scientists can predict with a fairly high degree of accuracy that a given soil will have a high water table within certain depths in most years, but they cannot predict that a high water table will always be at a specific level in the soil on a specific date.

After soil scientists located and identified the significant natural bodies of soil in the survey area, they drew the boundaries of these bodies on aerial photographs and

Custom Soil Resource Report

identified each as a specific map unit. Aerial photographs show trees, buildings, fields, roads, and rivers, all of which help in locating boundaries accurately.

Soil Map

The soil map section includes the soil map for the defined area of interest, a list of soil map units on the map and extent of each map unit, and cartographic symbols displayed on the map. Also presented are various metadata about data used to produce the map, and a description of each soil map unit.

Custom Soil Resource Report Soil Map

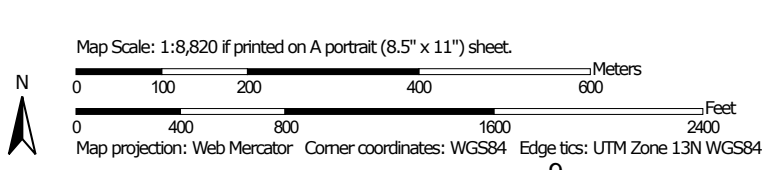

MAP LEGEND

Area of Interest (AOI)

 Area of Interest (AOI)



















Soils

 Soil Map Unit Polygons

 Soil Map Unit Lines

 Soil Map Unit Points

Special Point Features





-  Blowout
-  Borrow Pit
-  Clay Spot
-  Closed Depression
-  Gravel Pit
-  Gravelly Spot
-  Landfill
-  Lava Flow
-  Marsh or swamp
-  Mine or Quarry
-  Miscellaneous Water
-  Perennial Water
-  Rock Outcrop
-  Saline Spot
-  Sandy Spot
-  Severely Eroded Spot
-  Sinkhole
-  Slide or Slip
-  Sodic Spot

-  Spoil Area
-  Stony Spot
-  Very Stony Spot
-  Wet Spot
-  Other
-  Special Line Features

Water Features

 Streams and Canals

Transportation

-  Rails
-  Interstate Highways
-  US Routes
-  Major Roads
-  Local Roads

Background

 Aerial Photography

MAP INFORMATION

The soil surveys that comprise your AOI were mapped at 1:24,000.

Warning: Soil Map may not be valid at this scale.

Enlargement of maps beyond the scale of mapping can cause misunderstanding of the detail of mapping and accuracy of soil line placement. The maps do not show the small areas of contrasting soils that could have been shown at a more detailed scale.

Please rely on the bar scale on each map sheet for map measurements.

Source of Map: Natural Resources Conservation Service
 Web Soil Survey URL:
 Coordinate System: Web Mercator (EPSG:3857)

Maps from the Web Soil Survey are based on the Web Mercator projection, which preserves direction and shape but distorts distance and area. A projection that preserves area, such as the Albers equal-area conic projection, should be used if more accurate calculations of distance or area are required.

This product is generated from the USDA-NRCS certified data as of the version date(s) listed below.

Soil Survey Area: El Paso County Area, Colorado
 Survey Area Data: Version 19, Aug 31, 2021

Soil map units are labeled (as space allows) for map scales 1:50,000 or larger.

Date(s) aerial images were photographed: Aug 19, 2018—Sep 23, 2018

The orthophoto or other base map on which the soil lines were compiled and digitized probably differs from the background imagery displayed on these maps. As a result, some minor shifting of map unit boundaries may be evident.

Map Unit Legend

Map Unit Symbol	Map Unit Name	Acres in AOI	Percent of AOI
10	Blendon sandy loam, 0 to 3 percent slopes	6.9	2.4%
28	Ellicott loamy coarse sand, 0 to 5 percent slopes	29.5	10.1%
85	Stapleton-Bernal sandy loams, 3 to 20 percent slopes	2.0	0.7%
97	Truckton sandy loam, 3 to 9 percent slopes	254.2	86.9%
Totals for Area of Interest		292.7	100.0%

Map Unit Descriptions

The map units delineated on the detailed soil maps in a soil survey represent the soils or miscellaneous areas in the survey area. The map unit descriptions, along with the maps, can be used to determine the composition and properties of a unit.

A map unit delineation on a soil map represents an area dominated by one or more major kinds of soil or miscellaneous areas. A map unit is identified and named according to the taxonomic classification of the dominant soils. Within a taxonomic class there are precisely defined limits for the properties of the soils. On the landscape, however, the soils are natural phenomena, and they have the characteristic variability of all natural phenomena. Thus, the range of some observed properties may extend beyond the limits defined for a taxonomic class. Areas of soils of a single taxonomic class rarely, if ever, can be mapped without including areas of other taxonomic classes. Consequently, every map unit is made up of the soils or miscellaneous areas for which it is named and some minor components that belong to taxonomic classes other than those of the major soils.

Most minor soils have properties similar to those of the dominant soil or soils in the map unit, and thus they do not affect use and management. These are called noncontrasting, or similar, components. They may or may not be mentioned in a particular map unit description. Other minor components, however, have properties and behavioral characteristics divergent enough to affect use or to require different management. These are called contrasting, or dissimilar, components. They generally are in small areas and could not be mapped separately because of the scale used. Some small areas of strongly contrasting soils or miscellaneous areas are identified by a special symbol on the maps. If included in the database for a given area, the contrasting minor components are identified in the map unit descriptions along with some characteristics of each. A few areas of minor components may not have been observed, and consequently they are not mentioned in the descriptions, especially where the pattern was so complex that it was impractical to make enough observations to identify all the soils and miscellaneous areas on the landscape.

Custom Soil Resource Report

The presence of minor components in a map unit in no way diminishes the usefulness or accuracy of the data. The objective of mapping is not to delineate pure taxonomic classes but rather to separate the landscape into landforms or landform segments that have similar use and management requirements. The delineation of such segments on the map provides sufficient information for the development of resource plans. If intensive use of small areas is planned, however, onsite investigation is needed to define and locate the soils and miscellaneous areas.

An identifying symbol precedes the map unit name in the map unit descriptions. Each description includes general facts about the unit and gives important soil properties and qualities.

Soils that have profiles that are almost alike make up a *soil series*. Except for differences in texture of the surface layer, all the soils of a series have major horizons that are similar in composition, thickness, and arrangement.

Soils of one series can differ in texture of the surface layer, slope, stoniness, salinity, degree of erosion, and other characteristics that affect their use. On the basis of such differences, a soil series is divided into *soil phases*. Most of the areas shown on the detailed soil maps are phases of soil series. The name of a soil phase commonly indicates a feature that affects use or management. For example, Alpha silt loam, 0 to 2 percent slopes, is a phase of the Alpha series.

Some map units are made up of two or more major soils or miscellaneous areas. These map units are complexes, associations, or undifferentiated groups.

A *complex* consists of two or more soils or miscellaneous areas in such an intricate pattern or in such small areas that they cannot be shown separately on the maps. The pattern and proportion of the soils or miscellaneous areas are somewhat similar in all areas. Alpha-Beta complex, 0 to 6 percent slopes, is an example.

An *association* is made up of two or more geographically associated soils or miscellaneous areas that are shown as one unit on the maps. Because of present or anticipated uses of the map units in the survey area, it was not considered practical or necessary to map the soils or miscellaneous areas separately. The pattern and relative proportion of the soils or miscellaneous areas are somewhat similar. Alpha-Beta association, 0 to 2 percent slopes, is an example.

An *undifferentiated group* is made up of two or more soils or miscellaneous areas that could be mapped individually but are mapped as one unit because similar interpretations can be made for use and management. The pattern and proportion of the soils or miscellaneous areas in a mapped area are not uniform. An area can be made up of only one of the major soils or miscellaneous areas, or it can be made up of all of them. Alpha and Beta soils, 0 to 2 percent slopes, is an example.

Some surveys include *miscellaneous areas*. Such areas have little or no soil material and support little or no vegetation. Rock outcrop is an example.

El Paso County Area, Colorado

10—Blendon sandy loam, 0 to 3 percent slopes

Map Unit Setting

National map unit symbol: 3671
Elevation: 6,000 to 6,800 feet
Mean annual precipitation: 14 to 16 inches
Mean annual air temperature: 46 to 48 degrees F
Frost-free period: 125 to 145 days
Farmland classification: Not prime farmland

Map Unit Composition

Blendon and similar soils: 98 percent
Minor components: 2 percent
Estimates are based on observations, descriptions, and transects of the mapunit.

Description of Blendon

Setting

Landform: Terraces, alluvial fans
Down-slope shape: Linear
Across-slope shape: Linear
Parent material: Sandy alluvium derived from arkose

Typical profile

A - 0 to 10 inches: sandy loam
Bw - 10 to 36 inches: sandy loam
C - 36 to 60 inches: gravelly sandy loam

Properties and qualities

Slope: 0 to 3 percent
Depth to restrictive feature: More than 80 inches
Drainage class: Well drained
Runoff class: Low
Capacity of the most limiting layer to transmit water (Ksat): Moderately high to high
(0.60 to 2.00 in/hr)
Depth to water table: More than 80 inches
Frequency of flooding: None
Frequency of ponding: None
Calcium carbonate, maximum content: 2 percent
Available water supply, 0 to 60 inches: Moderate (about 6.2 inches)

Interpretive groups

Land capability classification (irrigated): None specified
Land capability classification (nonirrigated): 3e
Hydrologic Soil Group: B
Ecological site: R049XB210CO - Sandy Foothill
Hydric soil rating: No

Minor Components

Other soils

Percent of map unit: 1 percent
Hydric soil rating: No

Pleasant

Percent of map unit: 1 percent
Landform: Depressions
Hydric soil rating: Yes

28—Ellicott loamy coarse sand, 0 to 5 percent slopes

Map Unit Setting

National map unit symbol: 3680
Elevation: 5,500 to 6,500 feet
Mean annual precipitation: 13 to 15 inches
Mean annual air temperature: 47 to 50 degrees F
Frost-free period: 125 to 145 days
Farmland classification: Not prime farmland

Map Unit Composition

Ellicott and similar soils: 97 percent
Minor components: 3 percent
Estimates are based on observations, descriptions, and transects of the mapunit.

Description of Ellicott

Setting

Landform: Flood plains, stream terraces
Landform position (three-dimensional): Tread
Down-slope shape: Linear
Across-slope shape: Linear
Parent material: Sandy alluvium

Typical profile

A - 0 to 4 inches: loamy coarse sand
C - 4 to 60 inches: stratified coarse sand to sandy loam

Properties and qualities

Slope: 0 to 5 percent
Depth to restrictive feature: More than 80 inches
Drainage class: Somewhat excessively drained
Runoff class: Very low
Capacity of the most limiting layer to transmit water (Ksat): High to very high (5.95 to 19.98 in/hr)
Depth to water table: More than 80 inches
Frequency of flooding: FrequentNone
Frequency of ponding: None
Available water supply, 0 to 60 inches: Low (about 4.1 inches)

Interpretive groups

Land capability classification (irrigated): None specified
Land capability classification (nonirrigated): 7w
Hydrologic Soil Group: A
Ecological site: R069XY031CO - Sandy Bottomland LRU's A and B

Other vegetative classification: SANDY BOTTOMLAND (069AY031CO)
Hydric soil rating: No

Minor Components

Fluvaquentic haplaquoll

Percent of map unit: 1 percent
Landform: Swales
Hydric soil rating: Yes

Other soils

Percent of map unit: 1 percent
Hydric soil rating: No

Pleasant

Percent of map unit: 1 percent
Landform: Depressions
Hydric soil rating: Yes

85—Stapleton-Bernal sandy loams, 3 to 20 percent slopes

Map Unit Setting

National map unit symbol: 36b1
Elevation: 6,500 to 6,800 feet
Mean annual precipitation: 14 to 16 inches
Mean annual air temperature: 46 to 48 degrees F
Frost-free period: 125 to 145 days
Farmland classification: Not prime farmland

Map Unit Composition

Stapleton and similar soils: 55 percent
Bernal and similar soils: 44 percent
Minor components: 1 percent
Estimates are based on observations, descriptions, and transects of the mapunit.

Description of Stapleton

Setting

Landform: Hills
Landform position (three-dimensional): Side slope, crest
Down-slope shape: Linear
Across-slope shape: Linear
Parent material: Sandy alluvium derived from arkose

Typical profile

A - 0 to 11 inches: sandy loam
Bw - 11 to 17 inches: gravelly sandy loam
C - 17 to 60 inches: gravelly loamy sand

Properties and qualities

Slope: 3 to 15 percent
Depth to restrictive feature: More than 80 inches

Custom Soil Resource Report

Drainage class: Well drained
Runoff class: Low
Capacity of the most limiting layer to transmit water (Ksat): High (2.00 to 6.00 in/hr)
Depth to water table: More than 80 inches
Frequency of flooding: None
Frequency of ponding: None
Available water supply, 0 to 60 inches: Low (about 4.7 inches)

Interpretive groups

Land capability classification (irrigated): None specified
Land capability classification (nonirrigated): 4e
Hydrologic Soil Group: B
Ecological site: R049XY214CO - Gravelly Foothill
Hydric soil rating: No

Description of Bernal

Setting

Landform: Hills
Landform position (three-dimensional): Side slope, crest
Down-slope shape: Linear
Across-slope shape: Linear
Parent material: Residuum weathered from sandstone

Typical profile

A - 0 to 4 inches: sandy loam
Bt - 4 to 11 inches: sandy clay loam
C - 11 to 13 inches: sandy loam
R - 13 to 17 inches: unweathered bedrock

Properties and qualities

Slope: 3 to 20 percent
Depth to restrictive feature: 8 to 20 inches to lithic bedrock
Drainage class: Well drained
Runoff class: Medium
Capacity of the most limiting layer to transmit water (Ksat): Moderately low to moderately high (0.06 to 0.20 in/hr)
Depth to water table: More than 80 inches
Frequency of flooding: None
Frequency of ponding: None
Available water supply, 0 to 60 inches: Very low (about 1.8 inches)

Interpretive groups

Land capability classification (irrigated): None specified
Land capability classification (nonirrigated): 6e
Hydrologic Soil Group: D
Ecological site: R049XB204CO - Shallow Foothill
Hydric soil rating: No

Minor Components

Other soils

Percent of map unit: 1 percent
Hydric soil rating: No

97—Truckton sandy loam, 3 to 9 percent slopes

Map Unit Setting

National map unit symbol: 2x0j2
Elevation: 5,300 to 6,850 feet
Mean annual precipitation: 14 to 19 inches
Mean annual air temperature: 48 to 52 degrees F
Frost-free period: 85 to 155 days
Farmland classification: Not prime farmland

Map Unit Composition

Truckton and similar soils: 85 percent
Minor components: 15 percent
Estimates are based on observations, descriptions, and transects of the mapunit.

Description of Truckton

Setting

Landform: Interfluves, hillslopes
Landform position (two-dimensional): Backslope
Landform position (three-dimensional): Side slope
Down-slope shape: Linear
Across-slope shape: Linear
Parent material: Re-worked alluvium derived from arkose

Typical profile

A - 0 to 4 inches: sandy loam
Bt1 - 4 to 12 inches: sandy loam
Bt2 - 12 to 19 inches: sandy loam
C - 19 to 80 inches: sandy loam

Properties and qualities

Slope: 3 to 9 percent
Depth to restrictive feature: More than 80 inches
Drainage class: Well drained
Runoff class: Low
Capacity of the most limiting layer to transmit water (Ksat): High (2.00 to 6.00 in/hr)
Depth to water table: More than 80 inches
Frequency of flooding: None
Frequency of ponding: None
Calcium carbonate, maximum content: 1 percent
Maximum salinity: Nonsaline (0.1 to 1.9 mmhos/cm)
Available water supply, 0 to 60 inches: Moderate (about 6.6 inches)

Interpretive groups

Land capability classification (irrigated): 6e
Land capability classification (nonirrigated): 6e
Hydrologic Soil Group: A

Custom Soil Resource Report

Ecological site: R049XB210CO - Sandy Foothill
Hydric soil rating: No

Minor Components

Blakeland

Percent of map unit: 8 percent
Landform: Interfluves, hillslopes
Landform position (two-dimensional): Summit, shoulder, backslope
Landform position (three-dimensional): Side slope, crest
Down-slope shape: Convex, linear
Across-slope shape: Convex, linear
Ecological site: R049XB210CO - Sandy Foothill
Hydric soil rating: No

Bresser

Percent of map unit: 7 percent
Landform: Interfluves, low hills
Landform position (two-dimensional): Footslope, toeslope
Landform position (three-dimensional): Base slope
Down-slope shape: Concave, linear
Across-slope shape: Concave, linear
Ecological site: R049XB210CO - Sandy Foothill
Hydric soil rating: No

References

- American Association of State Highway and Transportation Officials (AASHTO). 2004. Standard specifications for transportation materials and methods of sampling and testing. 24th edition.
- American Society for Testing and Materials (ASTM). 2005. Standard classification of soils for engineering purposes. ASTM Standard D2487-00.
- Cowardin, L.M., V. Carter, F.C. Golet, and E.T. LaRoe. 1979. Classification of wetlands and deep-water habitats of the United States. U.S. Fish and Wildlife Service FWS/OBS-79/31.
- Federal Register. July 13, 1994. Changes in hydric soils of the United States.
- Federal Register. September 18, 2002. Hydric soils of the United States.
- Hurt, G.W., and L.M. Vasilas, editors. Version 6.0, 2006. Field indicators of hydric soils in the United States.
- National Research Council. 1995. Wetlands: Characteristics and boundaries.
- Soil Survey Division Staff. 1993. Soil survey manual. Soil Conservation Service. U.S. Department of Agriculture Handbook 18. http://www.nrcs.usda.gov/wps/portal/nrcs/detail/national/soils/?cid=nrcs142p2_054262
- Soil Survey Staff. 1999. Soil taxonomy: A basic system of soil classification for making and interpreting soil surveys. 2nd edition. Natural Resources Conservation Service, U.S. Department of Agriculture Handbook 436. http://www.nrcs.usda.gov/wps/portal/nrcs/detail/national/soils/?cid=nrcs142p2_053577
- Soil Survey Staff. 2010. Keys to soil taxonomy. 11th edition. U.S. Department of Agriculture, Natural Resources Conservation Service. http://www.nrcs.usda.gov/wps/portal/nrcs/detail/national/soils/?cid=nrcs142p2_053580
- Tiner, R.W., Jr. 1985. Wetlands of Delaware. U.S. Fish and Wildlife Service and Delaware Department of Natural Resources and Environmental Control, Wetlands Section.
- United States Army Corps of Engineers, Environmental Laboratory. 1987. Corps of Engineers wetlands delineation manual. Waterways Experiment Station Technical Report Y-87-1.
- United States Department of Agriculture, Natural Resources Conservation Service. National forestry manual. http://www.nrcs.usda.gov/wps/portal/nrcs/detail/soils/home/?cid=nrcs142p2_053374
- United States Department of Agriculture, Natural Resources Conservation Service. National range and pasture handbook. <http://www.nrcs.usda.gov/wps/portal/nrcs/detail/national/landuse/rangepasture/?cid=stelprdb1043084>

Custom Soil Resource Report

United States Department of Agriculture, Natural Resources Conservation Service. National soil survey handbook, title 430-VI. http://www.nrcs.usda.gov/wps/portal/nrcs/detail/soils/scientists/?cid=nrcs142p2_054242

United States Department of Agriculture, Natural Resources Conservation Service. 2006. Land resource regions and major land resource areas of the United States, the Caribbean, and the Pacific Basin. U.S. Department of Agriculture Handbook 296. http://www.nrcs.usda.gov/wps/portal/nrcs/detail/national/soils/?cid=nrcs142p2_053624

United States Department of Agriculture, Soil Conservation Service. 1961. Land capability classification. U.S. Department of Agriculture Handbook 210. http://www.nrcs.usda.gov/Internet/FSE_DOCUMENTS/nrcs142p2_052290.pdf

4/26/2022

Geotechnical Evaluation Report

Proposed Sand Creek Pond No. 2 Improvements

Vicinity of Barnes Road and Tutt Boulevard

Colorado Springs, Colorado

VIVID Project No.: D21-2-389

Revision 1



Only the client or it's designated representatives may use this document
and only for the specific project for which this report was prepared.

March 7, 2022

Revised: April 26, 2022

Report prepared for:

Theresa Ring, PE
Merrick & Company
2480 W. 26th Ave., Suite 225B
Denver, CO 80211
Theresa.Ring@merrick.com

**GEOTECHNICAL EVALUATION REPORT
Proposed Sand Creek Pond No. 2 Improvements
Vicinity of Barnes Road and Tutt Boulevard
Colorado Springs, Colorado
VIVID Project No.: D21-2-389**

Prepared by:

Mary Ray

Mary Ray
Engineering Geologist



William J. Barreire, P.E.
Senior Geotechnical Engineer

VIVID Engineering Group, Inc.
1053 Elkton Drive
Colorado Springs, CO 80907
(719) 896-4356 phone
(719) 896-4357 fax

Table of Contents

1.0	INTRODUCTION	1
1.1	GENERAL	1
1.2	PROJECT DESCRIPTION.....	1
1.3	PURPOSE AND SCOPE	1
2.0	FIELD EXPLORATION AND LABORATORY TESTING	3
2.1	FIELD EXPLORATION.....	3
2.2	GEOTECHNICAL LABORATORY TESTING.....	3
2.3	ANALYTICAL LABORATORY TESTING	4
3.0	SITE CONDITIONS.....	5
3.1	SURFACE.....	5
3.2	GEOLOGY.....	5
3.3	SUBSURFACE	5
3.3.1	Groundwater	6
4.0	CONCLUSIONS AND RECOMMENDATIONS	7
4.1	GEOTECHNICAL FEASIBILITY OF PROPOSED CONSTRUCTION.....	7
4.2	CONSTRUCTION CONSIDERATIONS	8
4.2.1	General	8
4.2.2	Site Preparation and Grading	8
4.2.3	Excavation Characteristics	8
4.2.4	Fill Materials	9
4.2.5	Utility Trench Backfill (if applicable).....	10
4.2.6	Compaction Requirements.....	11
4.2.7	Construction in Wet or Cold Weather	12
4.2.8	Construction Testing and Observation	12
4.2.9	Channel Side Slopes.....	12
4.3	CUT-OFF WALL AND WEIR RECOMMENDATIONS.....	13
4.3.1	Design Parameters.....	13
4.4	CORROSIVITY AND CONCRETE	14
4.4.1	Corrosion Potential.....	14
4.4.2	Chemical Sulfate Susceptibility and Concrete Type	15

5.0 ADDITIONAL SERVICES & LIMITATIONS..... 16
5.1 ADDITIONAL SERVICES 16
5.2 LIMITATIONS 16

Figure 1: Vicinity Map

Figure 2: Boring Location Plan

Appendix A: Logs of Exploratory Borings

Appendix B: Geotechnical Laboratory Test Results

Appendix C: Analytical Laboratory Test Results

Appendix D: Site Photos

Appendix E: Important Information About This Geotechnical Engineering Report

1.0 INTRODUCTION

1.1 GENERAL

This report presents the results of a geotechnical investigation performed for the proposed channel and pond improvements to the existing Sand Creek Pond No. 2 located in the vicinity of Barnes Road and Tutt Boulevard in Colorado Springs, Colorado. An attached Vicinity Map (Figure 1) shows the general location of the project. Our investigation was performed for Merrick & Company, Inc. and was authorized by Mr. Walt Pennington.

This report includes our recommendations relating to the geotechnical aspects of project design and construction. The conclusions and recommendations stated in this report are based upon the subsurface conditions found at the locations of our exploratory borings at the time our exploration was performed. They also are subject to the provisions stated in the report section titled **Additional Services & Limitations**. Our findings, conclusions, and recommendations should not be extrapolated to other areas or used for other projects without our prior review. Furthermore, they should not be used if the site has been altered, or if a prolonged period has elapsed since the date of the report, without VIVID's prior review to determine if they remain valid.

1.2 PROJECT DESCRIPTION

Based on information provided by Merrick & Company, we understand that a new concrete arc wall/weir is to be constructed north of the existing outlet. Other areas of detention pond, channel bank and channel stabilization including a modified flow spreader on the north side of the pond are proposed within the channel segment. We understand the modified flow spreader will consist of excavating into the existing soil-cement. Cut-off walls are proposed within the north side of the pond. A walking trail is planned to be constructed through the wetland area of the pond. The existing cement-treated soil access road at the base of the existing southern outlet structure is to be removed. The approximate locations of the proposed weir and flow spreader were provided after the completion of our field investigation within a conceptual document provided by Merrick. We understand that retaining walls are not included in the scope of work.

Future improvements may include the use of new soil-cement. Recommendations for soil-cement mix design can be provided if desired but based on recent conversations with Merrick, we have excluded this service from this report at this time.

VIVID previously performed a visual evaluation of the conditions of the existing soil-cement drop structure, located north of the existing pond. The results of this evaluation were provided under separate cover.

1.3 PURPOSE AND SCOPE

The purpose of our investigation was to explore and evaluate subsurface conditions at various accessible locations on the site and, based upon the conditions found, to develop recommendations relating to the geotechnical aspects of project design and construction. Our conclusions and recommendations in this report are based upon analysis of the data from our field exploration, laboratory tests, and our experience with similar soil and geologic conditions in the area.



VIVID's scope of services included:

- A visual reconnaissance to observe surface and geologic conditions at the project site and locating the exploratory borings;
- Notification of the Utility Notification Center of Colorado (UNCC) to identify underground utility lines at the boring locations prior to our drilling;
- The drilling and sampling of subsurface materials in three exploratory borings within or near the area of the proposed improvements. The locations were selected based upon the proposed construction plans, access, and utilities;
- Laboratory testing of selected samples obtained during the field exploration to evaluate relevant physical and engineering properties of the soil and bedrock;
- Evaluation and engineering analysis of the field and laboratory data collected to develop our geotechnical conclusions and recommendations; and
- Preparation of this report, which includes a description of the proposed project, a description of the surface and subsurface site conditions found during our investigation, our conclusions and recommendations as to foundation design for the proposed cut-off walls and embankment/weir structure and construction, other related geotechnical issues, and appendices which summarize our field and laboratory investigations.

2.0 FIELD EXPLORATION AND LABORATORY TESTING

2.1 FIELD EXPLORATION

A field exploration performed on January 13, 2022, included drilling three exploratory borings at the approximate locations shown on Figures 2, which are near the proposed improvements. A summary of the subsurface exploration is presented below.

Table 1
Summary of Subsurface Exploration

Boring Designation	Approximate Total Depth of Exploration [feet, bgs]¹	Approximate Depth to Bedrock [feet, bgs]¹	Approximate Depth to Groundwater at time of drilling [feet, bgs]¹
B-1	29.5	12.0	3.0
B-2	29.5	14.0	8.0
B-3	24.5	9.0	4.0

1. Depths referenced to feet below existing ground surface (bgs).

The borings were advanced using a CME-850 track-mounted drill rig equipped with 8-inch outside diameter, hollow-stem auger. Samples were taken with a 2.0-inch I.D. California-type sampler, SPT sampler, and by bulk methods. Penetration tests were obtained at the various sample depths as well.

Appendix A to this report includes logs describing the subsurface conditions. The lines defining boundaries between soil and rock types on the logs are based upon drill behavior and interpolation between samples and are therefore approximate. Transition between soil and rock types may be abrupt or may be gradual.

2.2 GEOTECHNICAL LABORATORY TESTING

Laboratory tests were performed on selected soil samples to estimate their relative engineering properties. Tests were performed in general accordance with the following methods of ASTM or other recognized standards-setting bodies, and local practice:

- Description and Identification of Soils (Visual-Manual Procedure)
- Classification of Soils for Engineering Purposes
- Moisture Content and Unit Weight
- Sieve Analysis of Fine and Coarse Aggregates
- Liquid Limit, Plastic Limit, and Plasticity Index
- Unconfined Compressive Strength

Results of the geotechnical laboratory tests are included in Appendix B of this report. Selected test results are also shown on the boring logs in Appendix A.

2.3 ANALYTICAL LABORATORY TESTING

Analytical testing for soil corrosivity was performed on selected samples and included the following tests:

- pH
- Resistivity
- Redox Potential
- Water-soluble Sulfates
- Water-soluble Chlorides
- Sulfides

Results of the analytical laboratory tests are presented in the report text, where applicable, and included in Appendix C of this report

3.0 SITE CONDITIONS

3.1 SURFACE

The borings were advanced at accessible locations that were within or as near as safely possible to the proposed improvements, and clear of existing buried and overhead utilities. The existing pond is located southeast of the intersection of Barnes Road and Tutt Boulevard, directly south of Security Service Field in Colorado Springs, Colorado. Commercial buildings surrounded the pond to the west and south. A residential subdivision was being developed to the southeast and east of the pond. A soil-cement embankment wrapped the perimeter of the pond with an access road on the top of the south and east sides. The pond bottom was heavily vegetated with cotton tails and other wetland plants and brush. Several inches of standing water were observed on the south and east sides of the pond.

A large concrete outlet structure was present on the south side of the pond and a smaller outlet structure was present on the west side. A drop structure constructed with cement-treated soils was present at the north side of the pond. The pond surface was generally soft, wet, and sloped down to the south.

3.2 GEOLOGY

Prior to drilling, the site geology was evaluated by reviewing geologic maps including the CGS Geologic Map of Falcon NW 7.5 Minute Quadrangle, El Paso County, Colorado (Madole, 2003). Mapping indicates the surficial soils in the general area of the project site comprise of sand, clay and gravel alluvium soils underlain by sandstone and claystone bedrock consisting of Dawson Formation. The mapping is generally consistent with our explorations. However, fill materials presumably associated with the construction of the existing embankment were encountered at the ground surface in the borings advanced near the existing outlet.

3.3 SUBSURFACE

VIVID explored the subsurface conditions along the proposed channel and pond improvements by drilling, logging, and sampling of three exploratory borings. The borings were advanced to depths ranging between approximately 24.5 and 29.5 feet below the existing ground surface. The general profile encountered in our borings consisted of:

Fill

Existing fill was encountered at the ground surface in borings B-1 and B-2 and extended to approximately 8 feet below the existing ground surface. The fill material consisted of silty sand, was grayish-brown in color and hard to very hard based on drilling observations and field penetration resistance testing (blow counts). We believe the fill material may be cement-treated soil that was placed during the construction of the southern embankment.

Alluvium

Native soils comprised predominately of silty to clayey sand, poorly graded sand with silt and gravel as well as thin layers of elastic silt with sand were encountered at the ground surface or below the unit described above and extended to depths of approximately 9 to 14 feet below the ground surface. The materials were generally grayish-brown, light brown, and light gray in color, moist to wet, and field penetration testing (blow counts) indicated the relative density of the sand soils was generally loose to medium dense and the silt soils were stiff.

Bedrock

Weathered to comparatively unweathered bedrock of the Dawson Formation was encountered in each boring beneath the units described above at depths presented in Table 1 (above) and extended to the maximum depth explored in each of these borings. The bedrock consisted predominantly of interbedded sandstone and claystone. The sandstone and claystone bedrock were generally gray, grayish-brown and yellowish-brown, moist to wet, and hard to very hard.

The boring logs in Appendix A should be reviewed for more detailed descriptions of the subsurface conditions at each of the boring locations explored.

3.3.1 Groundwater

Groundwater was encountered at the time of drilling at the boring locations and approximate depths shown in Table 1, above. Due to the proximity of the borings to an active drainage channel, groundwater levels commonly vary over time and space depending on seasonal precipitation, irrigation practices, land use, and runoff conditions. These conditions and the variations that they create often are not apparent at the time of field investigation. Accordingly, the soil moisture and groundwater data in this report pertain only to the locations and times at which exploration was performed. They can be extrapolated to other locations and times only with caution. It should also be noted that VIVID has not performed a hydrologic study to verify the seasonal high-water level.

4.0 CONCLUSIONS AND RECOMMENDATIONS

4.1 GEOTECHNICAL FEASIBILITY OF PROPOSED CONSTRUCTION

VIVID found no subsurface conditions during this investigation that would preclude construction of the project as planned. We understand that the channel and pond improvements will include the construction of cut-off walls at the north side of the pond and a weir at the south side, just north of the existing outlet structure. The project also includes minor grading related to channel realignment. We anticipate regrading of the existing channel side slopes in some areas along the channel banks may be included.

The major geotechnical issues with this project/site include variable subgrade support characteristics ranging from loose/soft sand and silt soils to hard bedrock, existing, hard cement-treated soils, shallow groundwater and surface water in the channel bottom that will impact weir and cut-off wall construction, potential for relatively high surface water flows during/after storm events, and the highly erodible nature of the near-surface alluvium soils. These challenges will be addressed with a combination of design elements to reduce hydraulic forces and protect channel slopes with appropriate erosion protection measures. Construction challenges will be those typical to construction in active drainages including wet, unstable soils, and surface/groundwater control. The material type and compaction of this material will be critical to support and limiting settlement of the new structural features.

Groundwater/Surface Water

The presence of shallow groundwater and surface water creates loose/soft and wet soil conditions. Surface water was observed during our investigation. In addition, runoff and groundwater conditions and the location of the proposed improvements within the drainage channel and pond indicates that temporary dewatering and channelizing of surface water during construction will be necessary. Seasonal precipitation/runoff conditions, that are historically higher in the spring and early summer months, should be considered in construction scheduling. Structural features (e.g. weir and cut-off walls) should be designed and constructed with typical elements to prevent buildup of hydrostatic pressure (e.g. drains, weep-holes, etc.), as necessary.

Low Density Alluvial Soils

Zones of very moist, soft, unstable soils may be encountered during excavation. Extra measures may be required for stabilization of subgrade before fill placement as discussed in Section 4.2.2 of the report. Depending on final grades and hydraulic requirements, we recommend any proposed structures bear on a zone of properly prepared structural fill.

Excavation

Consideration should be given for the presence of groundwater and surface water and its effect on both short-term and long-term stability of slopes in the loose, sandy soils, as described herein. Additionally, any excavations that extend into the formational Dawson Formation bedrock should anticipate conditions varying from soft to very hard rock and difficult excavation operations.

4.2 CONSTRUCTION CONSIDERATIONS

4.2.1 General

All site preparation and earthwork operations should be performed in accordance with applicable codes, safety regulations and other local, State or Federal guidelines.

4.2.2 Site Preparation and Grading

Initial site work should consist of completely removing any organic material, trash, debris, and other deleterious materials from all areas to be filled and areas to be cut. Any existing structures that are planned for demolition should be completely removed. All material should be removed for offsite disposal in accordance with local laws and regulations or, if appropriate, stockpiled for future use. Areas to receive fill should be evaluated by the geotechnical engineer prior to the placement of any fill materials.

After performing the required subgrade preparation and excavations and prior to the placement of compacted fill, processing of the subgrade should be performed. This should include scarifying the subgrade soils to a depth of at least 8 inches, moisture conditioning and compacting as recommended in Section 4.2.6 of this report. If bedrock is encountered at bottom of excavation elevation, it must be scraped clean and relatively flat (**undisturbed bedrock should not be scarified**). All fill materials should be placed on a horizontal plane and placed in loose lifts not to exceed 8 inches in thickness, unless otherwise accepted by the geotechnical engineer.

Zones of very moist to wet, soft, unstable soils may be encountered during excavation and earthwork operations and will be dependent on the time of year construction is performed and precipitation events. If unstable conditions are encountered, the subgrade should be scarified, recompacted and proof-rolled prior to placement of fill. Use of rock, or combination of geo-grid and aggregate, can be used to stabilize areas that cannot otherwise be properly prepared for support of additional fill or structural elements. The optimal type and thickness of stabilization can only be evaluated when the conditions and magnitude of instability are exposed, but construction planning should address this need so it can be implemented when necessary.

4.2.3 Excavation Characteristics

Channel Alluvial Soils

We believe that excavation of the native alluvial soils can be readily accomplished using standard-duty excavating equipment appropriate for drainage work. Due to the relatively clean and soft/loose nature of the majority of the surficial soils, and where groundwater is encountered, these materials will slough/collapse when excavated.

Bedrock

Although not anticipated due to the deeper depths to the surface of the bedrock ranging between 9 and 14 feet below the existing ground surface, excavation into the bedrock could encounter soft to moderately hard conditions for more weathered zones to extremely difficult conditions for unweathered/formational bedrock zones. Relatively soft conditions could be encountered during excavation in the upper portions of bedrock material. The unweathered bedrock can be very hard and intact, making ripping of the bedrock extremely difficult.



Excavation equipment such as heavy-duty backhoes/trackhoes suitable for rock excavation, hoe rams, dozers equipped with rock excavating teeth/rippers and similar equipment will be required to excavate into the existing soil-cement and very hard sandstone bedrock materials, where required. We anticipate excavation in the harder materials could be relatively slow depending on the depth of excavation, the type of bedrock encountered, the type and site of equipment used, as well as the contractor's experience with similar excavation.

Dewatering/Shoring

Surface water was observed during the time of our investigation flowing from the northeast side of the pond down to the south culvert. Several inches of standing water was observed throughout the east side of the pond. Surface and groundwater infiltration will occur during construction operations, requiring construction dewatering. Utilizing appropriate construction dewatering equipment/systems such as well points, or sumps and trenches, cut-off walls, etc. will be the responsibility of the contractor. In addition, trenching into unstable, saturated overburden soils will require temporary shoring, where construction of safe slopes is not feasible. OSHA requirements for excavation in unstable materials should be followed.

All excavations must comply with applicable local, State and Federal safety regulations, and particularly with the excavation standards of the Occupational Safety and Health Administration (OSHA). Construction site safety, including excavation safety, is the sole responsibility of the Contractor as part of its overall responsibility for the means, methods, and sequencing of construction operations. VIVID's recommendations for excavation support are intended for the Client's use in planning the project, and in no way relieve the Contractor of its responsibility to construct, support and maintain safe slopes. Under no circumstances should the following recommendations be interpreted to mean that VIVID is assuming responsibility for either construction site safety or the Contractor's activities.

Due to zones of relatively clean and soft overburden soils encountered in the borings on this site, sloughing may occur in the alluvium soils and application of temporary shoring will be needed especially for deeper excavations. We believe that the soils on this site would classify as Type C materials using OSHA criteria under unsaturated conditions. OSHA requires that unsupported cuts be laid back to ratios no steeper than 1½:1 (horizontal to vertical) for Type C materials in unsaturated conditions. However, the hard and intact on-site soil-cement materials and bedrock may be classified as Type A material. OSHA requires that unsupported cuts up to 20 feet in height be laid back to ratios no steeper than ¾H:1V (horizontal to vertical) for a Type A material. In general, we believe that these slope ratios will be temporarily stable under unsaturated conditions. Where groundwater seepage occurs, which is anticipated to be at all locations within the existing pond bottom, flatter slopes and shoring will be required. Please note that the actual determination of soil type and allowable sloping must be made in the field by an OSHA-qualified "competent person."

4.2.4 Fill Materials

Based on our laboratory test results, the on-site granular (sand) alluvial soils are suitable for use as structural fill (e.g. compacted material below or adjacent proposed drop structures) for the planned construction. Soils with a higher silt/fines content were encountered in one of our borings (boring B-1 from approximately 8 to 12 feet). This type of material may be encountered at various locations and should not be re-used as structural fill. The type, placement, and compaction of fill materials will be important, especially in areas where the proposed structures will rely on the support of this fill. Fill

materials placed in the channel bottom and side slopes that will be exposed to the hydraulic action of the creek runoff must be approved by the hydraulic engineer. As such, fill types and areas within the pond/channel are described below:

- Structural fill: This material shall be placed below any foundation or structure elements and should include on-site sand soils, or if imported material is required, it should meet the requirements of Colorado Department of Transportation (CDOT) Class 1 Structure Backfill.
- Cut-off Wall backfill: Fill placed adjacent and within the lateral earth pressure zone of influence to any walls shall consist of on-site granular soils, or if imported material is required, it should meet CDOT Class I Structure Backfill specifications.
- Common fill: This material may be placed in lower zones of channel grading fill (i.e. between structures/structural fill areas) and can include a broader range of soil types including the on-site soils. **Common fill must be properly prepared and placed at a depth that will not be exposed to stream flow/erosive hydraulic forces. Wet on-site soils will need to be dried to within the compaction moisture criteria prior to re-compaction.**
- Stream Bed/Pond Surface Fill: This material may be placed in the upper zones of pond and channel grading fill that will be exposed to the hydraulic action of the creek flows. The material type will be determined by the hydraulic engineer but is anticipated to be granular materials that are suitable for exposure to erosive hydraulic forces.

Due to the relatively clean and cohesionless nature of some of the on-site granular soils, compaction machinery with small footprints like jumping jacks and use of vibration on final upper lifts may prove problematic for compaction. For these materials, large plate compactors, smooth drum rollers, or larger rubber tire equipment without vibration for final lifts may be more efficient. Laboratory maximum density determination of the clean on-site soils (for comparison of field compaction test results) may require the use of a relative density approach (Maximum Index Density and Unit Weight of Soils Using Vibratory Table, ASTM D 4253) as opposed to the more common Proctor curve method (ASTM D 1557).

A sample of proposed imported fill materials should be submitted to our office for review and testing at least 1 week prior to stockpiling at the site. Fill should be compacted according to the recommendations in Section 4.2.6 of this report. We recommend that a qualified representative of VIVID visit the site during excavation and during placement of fill to verify the subgrade is properly prepared and fill soils meet project requirements for material type and compaction.

4.2.5 Utility Trench Backfill (if applicable)

Backfill material should be essentially free of plant matter, organic soil, debris, trash, other deleterious matter, and rock particles larger than 4 inches. However, backfill material in the “pipe zone” (from the trench floor to 1-foot above the top of pipe) should not contain rock particles larger than 1 inch. Strictly observe any requirements specified by the utility agency for bedding and pipe-zone fill. In general, backfill above the pipe zone in utility trenches should be placed in lifts of 6 to 8 inches, and compacted using power equipment designed for trench work. Backfill in the pipe zone should be placed in lifts of 8 inches or less and compacted with hand-held equipment. Compact trench backfill as recommended in Section 4.2.6 of this report.

4.2.6 Compaction Requirements

Fill materials should be placed in horizontal lifts compatible with the type of compaction equipment being used, moisture conditioned, and compacted in accordance with the following criteria.

**Table 2
Compaction Specifications**

FILL LOCATION	MATERIAL TYPE (See Section 4.2.4)	PERCENT COMPACTION (ASTM D1557)	MOISTURE CONTENT
Subgrade Preparation (after clearing, grubbing, excavation, and prior to placement of new fill and/or structural elements)	On-site soils	90 minimum -or- stabilized per Section 4.2.2	± 2 % of optimum
Foundation Subgrade	On-site <u>Granular</u> Soils or CDOT Class I Structure Backfill	95 minimum	± 2 % of optimum
Structural Fill			
Utility Trench Backfill (if applicable)			
Potential Slope Re-Grading/ Embankment Fill			
Lower Zone of Channel Backfill ("Common Fill")	On-site Soils	90 minimum	± 2 % of optimum
Stream Bed/Pond Surface Fill	Materials Defined by Hydraulic Engineer	90 minimum	± 2 % of optimum

Laboratory maximum density determination of the clean on-site soils (for comparison of field compaction test results) may require the use of a relative density approach (Maximum Index Density and Unit Weight of Soils Using Vibratory Table, ASTM D 4253) as opposed to the more common Proctor curve method (ASTM D1557). If it is determined during the time of construction that a relative density approach is required, percent compaction specification will be determined upon completion of laboratory testing.

Fill should be placed in level lifts not exceeding 8 inches in loose thickness and compacted to the specified percent compaction to produce a firm and stable surface. If field density tests indicate the required percent compaction has not been obtained, the fill material should be reconditioned as necessary and re-compact to the required percent compaction before placing any additional material.

This being a drainage where unstable/pumping conditions are anticipated, stabilization using techniques such as shoving large rock or installation of geo-grid is common and should be anticipated where stable conditions cannot be obtained through moisture controls and compaction.

4.2.7 Construction in Wet or Cold Weather

Where working above groundwater or channel/pond water during construction, grade the site such that surface water can drain readily away from the work area. Promptly pump out or otherwise remove any water that may accumulate in excavations or on subgrade surfaces and allow these areas to dry before resuming construction. The use of berms, ditches and similar means may be used to prevent stormwater from entering the work area and to convey any water off site efficiently.

If earthwork is performed during the winter months when freezing is a factor, no grading fill, structural fill, or other fill should be placed on frosted or frozen ground, nor should frozen material be placed as fill. Frozen ground should be allowed to thaw or be completely removed prior to placement of fill. A good practice is to cover the compacted fill with a “blanket” of loose fill to help prevent the compacted fill from freezing.

If structures are erected during cold weather, foundations or other concrete elements should not be constructed on frozen soil. Frozen soil should be completely removed from beneath the concrete elements, or thawed, scarified and recompacted. The amount of time passing between excavation or subgrade preparation and placing concrete should be minimized during freezing conditions to prevent the prepared soils from freezing. The use of blankets, soil cover or heating as required may be utilized to prevent the subgrade from freezing.

4.2.8 Construction Testing and Observation

Testing and construction observation should take place under the direction of VIVID to support that engineer’s professional opinion as to whether the earthwork does or does not substantially conform to the recommendations in this report. Furthermore, the opinions and conclusions of a geotechnical report are based upon the interpretation of a limited amount of information obtained from the field exploration. It is therefore not uncommon to find that actual site conditions differ somewhat from those indicated in the report. The geotechnical engineer should remain involved throughout the project to evaluate such differing conditions as they appear, and to modify or add to the geotechnical recommendations, as necessary.

4.2.9 Channel Side Slopes

We anticipate that the side slopes will be constructed with maximum 3:1 (horizontal:vertical) slope configurations with areas of 4:1 configurations. Slopes with these configurations will need to be protected due to the erosive nature of the on-site soils, however they will be stable from a global stability standpoint provided they are not subject to saturation from adjacent runoff or bank seepage. If during construction seepage is noticed behind locations of new side slopes, installation of a back drain consisting of permeable sand/aggregate and a relief pipe(s) are highly recommended to avoid slumping/failure of newly constructed side slopes. The ground below the fill areas should be properly prepared prior to fill placement. All permanent cut and fill slopes must be re-vegetated and protected by mats or other means such as rip rap to control erosion.

Benching of fills into the existing slopes (if applicable) is critical to the stability of new fills. Benching of the fill into the existing slopes as the fill is brought up in layers should be performed. The height and width of the benching is dependent on existing slope geometry, size of equipment utilized, and safety requirements. As a general rule, each bench should be cut 5-feet horizontally into the original ground line



from the vertical side of the previous cut. We believe this will be possible where the existing slope is 1H:1V (horizontal:vertical) or shallower. Benching can be performed from bottom to top of slope as new layers of fill are placed. In areas where the existing slope is near vertical, the bucket of a track-hoe (or similar equipment) should be used to create “mini”- benches into the slope walls, if possible. Adjustments or other approaches will be required if slopes are unstable.

4.3 CUT-OFF WALL AND WEIR RECOMMENDATIONS

We understand that cut-off walls are planned on the north side of the pond and a weir is planned on the south side, just north of the existing outlet structure. **Due to the variable soil conditions, we recommend foundation elements bear entirely on a properly prepared bedrock surface, or at least 12 inches of properly compacted, onsite granular (sand) soils or imported structural fill per Section 4.2.4 of this report.** If a silt layer is encountered at the bottom of foundation elevation, it must be removed to expose granular (sand) soil and replaced with on-site or imported granular soils as described in Section 4.2.4 and compacted per Section 4.2.6 of this report. The foundation excavation should extend laterally at least 18 inches beyond the edge of the foundation element.

4.3.1 Design Parameters

Bearing Capacity

Due to the deeper depths to the surface of the bedrock ranging between 9 and 14 feet below the channel bottom, any CIP (cast-in-place) concrete cut-off walls (if utilized) and weir elements should be constructed on a properly prepared bedrock surface or 12-inch-thick zone of properly compacted structural fill. The subgrade should be prepared in accordance with Section 4.2.2 of this report, prior to the placement of structural fill and structural elements. Structural fill materials should meet the requirements presented in Section 4.2.4 and compacted in accordance with Section 4.2.6 of this report. A maximum allowable bearing capacity of 3,000 psf should be used for design of foundation elements. These bearing pressures may be increased by one-third for transient loading. A VIVID representative should observe the foundation excavations.

Lateral Earth Pressures

Walls that support soil at a higher grade on one side (i.e. retaining earth) should be designed to resist the following lateral earth pressures computed on the basis of an equivalent fluid unit weight for soils located adjacent the upstream side of the drop structure. These pressures are based on a granular soil assuming a phi angle of 30 degrees and buoyant unit weights (i.e. assume soils are situated below water level) for granular structural fill meeting the criteria presented in Section 4.2.4.

- Active earth pressure: 83 pounds per cubic foot (pcf)*
- At-rest earth pressure: 94 pcf*

The following passive earth pressures, presented as equivalent fluid pressure, to resist lateral loads may be used for the soils and bedrock located adjacent the downstream side of the drop structure. The pressures provided are considered ultimate parameters. **Because significant movement is required to fully mobilize passive earth pressure, we recommend a minimum factor of safety of 2 be applied for design purposes.**

- Structural Fill: 188 pounds per cubic foot (pcf)*

- Weathered Bedrock: 400 pcf
- Formational Bedrock: 500 pcf

**It should be noted that the hydrostatic water pressure (62.4 pcf) was already included in the above pressure values for structural fill only (not bedrock). Additional dynamic water forces should be added to the lateral earth pressure values presented above, as applicable.*

Fill should be placed in uniform lifts and compacted in accordance with this report. Care should be taken not to over-compact the backfill adjacent to structures since this could cause excessive lateral pressure and damage to the structures.

Sheet Pile Cut-off Wall Recommendations (if driven into bedrock)

Based on the field penetration resistance testing of bedrock obtained during drilling, the bedrock is moderately hard to very hard. Because of the variability of the bedrock, we anticipate sheet piling may not be driven to significant depths into the bedrock in some areas. Penetration of no more than 12 to 18 inches is expected before refusal occurs in some areas within the channel. It may be possible to pre-drill holes or trench into the bedrock along the proposed alignment to ease installation of sheet piling. If this condition occurs, concrete should be used to fill the resulting trench around the sheet pile.

Where driven steel sheet piling is used, we believe the sheet piling should be driven into the bedrock beneath surficial soils. Once bedrock is encountered, we recommend the sheet piling be driven to “seat” the sheet piling into the bedrock. Attempting to drive the sheet piling to achieve deeper penetration is likely to damage the sheet pile. Sheet pile sections should be selected to withstand the anticipated driving forces. In addition to the driving forces, the selection of a sheet pile section should also consider the soil and hydraulic forces as indicated within the report.

4.4 CORROSIVITY AND CONCRETE

4.4.1 Corrosion Potential

Laboratory testing was completed to provide data regarding corrosivity of onsite soils. Our scope of services does not include corrosion engineering and, therefore, a detailed analysis of the corrosion test results is not included. A qualified corrosion engineer should be retained to review the test results and design protective systems that may be required.

Laboratory chloride concentration, sulfate concentration, sulfide concentration, pH, oxidation reduction potential, and electrical resistivity tests were performed on a sample of on-site materials obtained during our field investigation. The results of the tests are included in Appendix C to this report and are summarized below in Table 3.

**Table 3
Summary of Laboratory Soil Corrosivity Testing**

Boring No.	Sample Depth (ft)	Sample Description	pH	Water Soluble Chloride (ppm)	Water Soluble Sulfate (%)	Sulfide Content	Resistivity (ohm-cm)	Redox Potential (mv)
B-1	0-4	Silty, Clayey SAND	8.95	160	0.0524	Positive	2,300	228
B-3	14	CLAYSTONE	7.6	89	0.1079	Negative	1,200	214

Metal and concrete elements in contact with soil, whether part of a foundation system or part of a supported structure, are subject to degradation due to corrosion or chemical attack. Therefore, buried metal and concrete elements should be designed to resist corrosion and degradation based on accepted practices.

Based on the “10-point” method developed by the American Water Works Association (AWWA) in standard AWWA C105/A21.5, corrosivity test results indicate high corrosive potential for the overburden clayey sand soils and the bedrock materials. We recommend that a corrosion engineer be consulted to recommend appropriate protective measures, if required.

4.4.2 Chemical Sulfate Susceptibility and Concrete Type

The degradation of concrete or cement grout can be caused by chemical agents in the soil or groundwater that react with concrete to either dissolve the cement paste or precipitate larger compounds within the concrete, causing cracking and flaking. The concentration of water-soluble sulfates in the soils is a good indicator of the potential for chemical attack of concrete or cement grout. The American Concrete Institute (ACI) in their publication Guide to Durable Concrete (ACI 201.2R-08) provides guidelines for this assessment.

The concentration of water-soluble sulfates measured in the near-surface sands and bedrock materials was less than 0.0524 and 0.1079 percent, respectively. These results indicate a Class 0 exposure of sulfate attack on concrete exposed to the overburden soils and a Class 1 exposure on concrete exposed to bedrock per CDOT Standard Specifications for Road and Bridge Construction, 2019, Section 601.04.

5.0 ADDITIONAL SERVICES & LIMITATIONS

5.1 ADDITIONAL SERVICES

Attached to this report is a document by the Geoprofessional Business Association (GBA) that summarizes limitations of geotechnical reports as well as additional services that are required to further confirm subgrade materials are consistent with that encountered at the specific boring locations presented in this report. This document should be read in its entirety before implementing design or construction activities. Examples of other services beyond completion of a geotechnical report are necessary or desirable to complete a project satisfactorily include:

- Review of design plans and specifications to verify that our recommendations were properly interpreted and implemented.
- Attendance at pre-bid and pre-construction meetings to highlight important items and clear up misunderstandings, ambiguities, or conflicts with design plans and specifications.
- Performance of construction observation and testing which allows verification that existing materials at locations beyond our borings are consistent with that presented in our report, construction is compliant with the requirements/recommendations, evaluation of changed conditions.

5.2 LIMITATIONS

This work was performed in a manner consistent with that level of care and skill ordinarily exercised by other members of VIVID's profession practicing in the same locality, under similar conditions and at the date the services are provided. Our conclusions, opinions, and recommendations are based on a limited number of observations and data. It is possible that conditions could vary between or beyond the data evaluated. VIVID makes no other representation, guarantee, or warranty, express or implied, regarding the services, communication (oral or written), report, opinion, or instrument of service provided.

This report may be used only by the Client and the registered design professional in responsible charge and only for the purposes stated for this specific engagement within a reasonable time from its issuance, but in no event later than two (2) years from the date of the report.

The work performed was based on project information provided by Client. If Client does not retain VIVID to review any plans and specifications, including any revisions or modifications to the plans and specifications, VIVID assumes no responsibility for the suitability of our recommendations. In addition, if there are any changes in the field to the plans and specifications, Client must obtain written approval from VIVID's engineer that such changes do not affect our recommendations. Failure to do so will vitiate VIVID's recommendations.

Figures

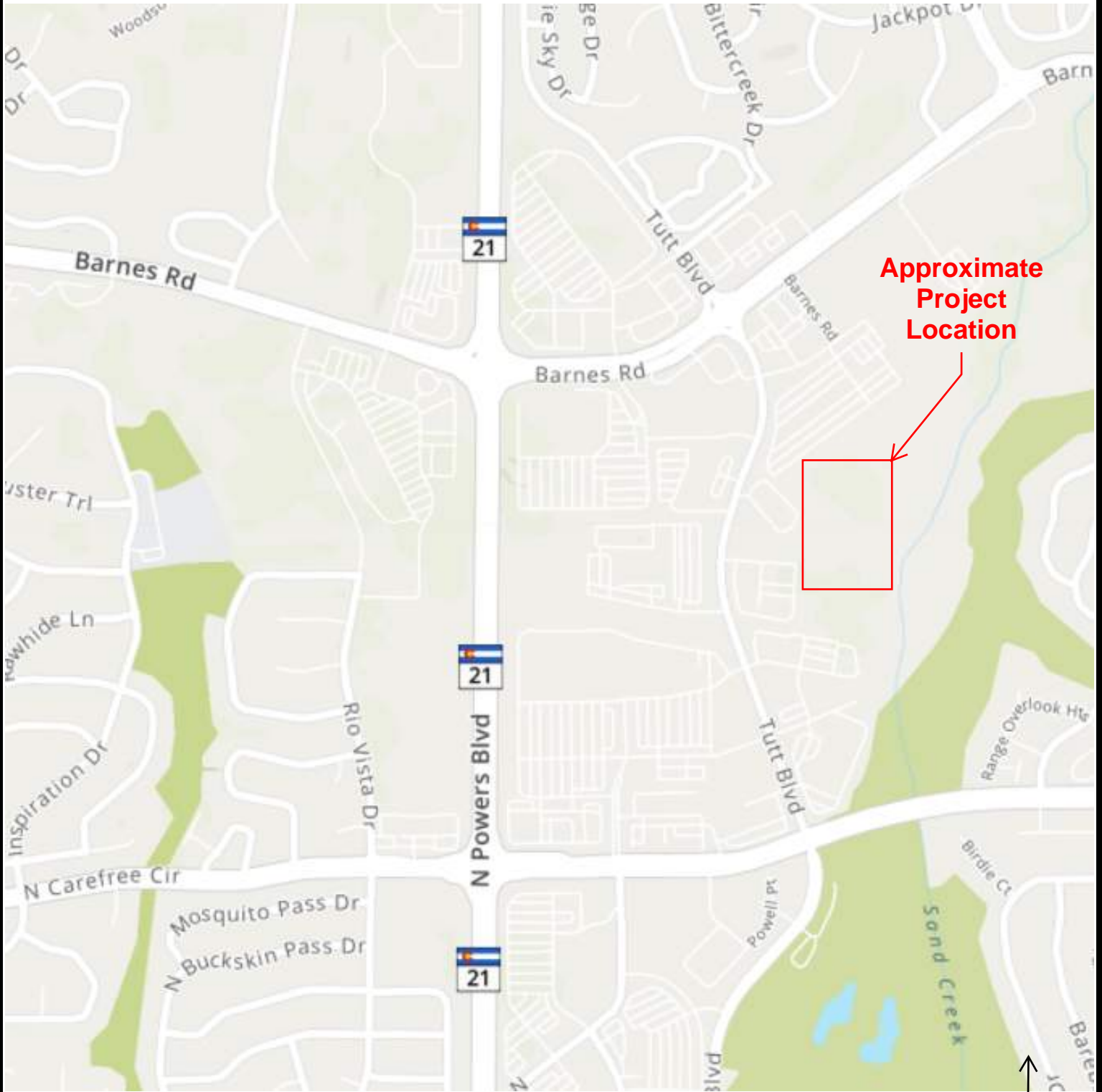

Not to Scale. Base image obtained from www.mapquest.com, 2022



Project No: D21-2-389
Date: March 7, 2022
Drawn by: MBR
Reviewed by: BTM

VICINITY MAP
Proposed Sand Creek Pond No. 2 Improvements Vicinity of Barnes Road and Tuttt Boulevard Colorado Springs, Colorado

Figure
1

LEGEND
 = APPROXIMATE LOCATION OF EXPLORATORY BORING

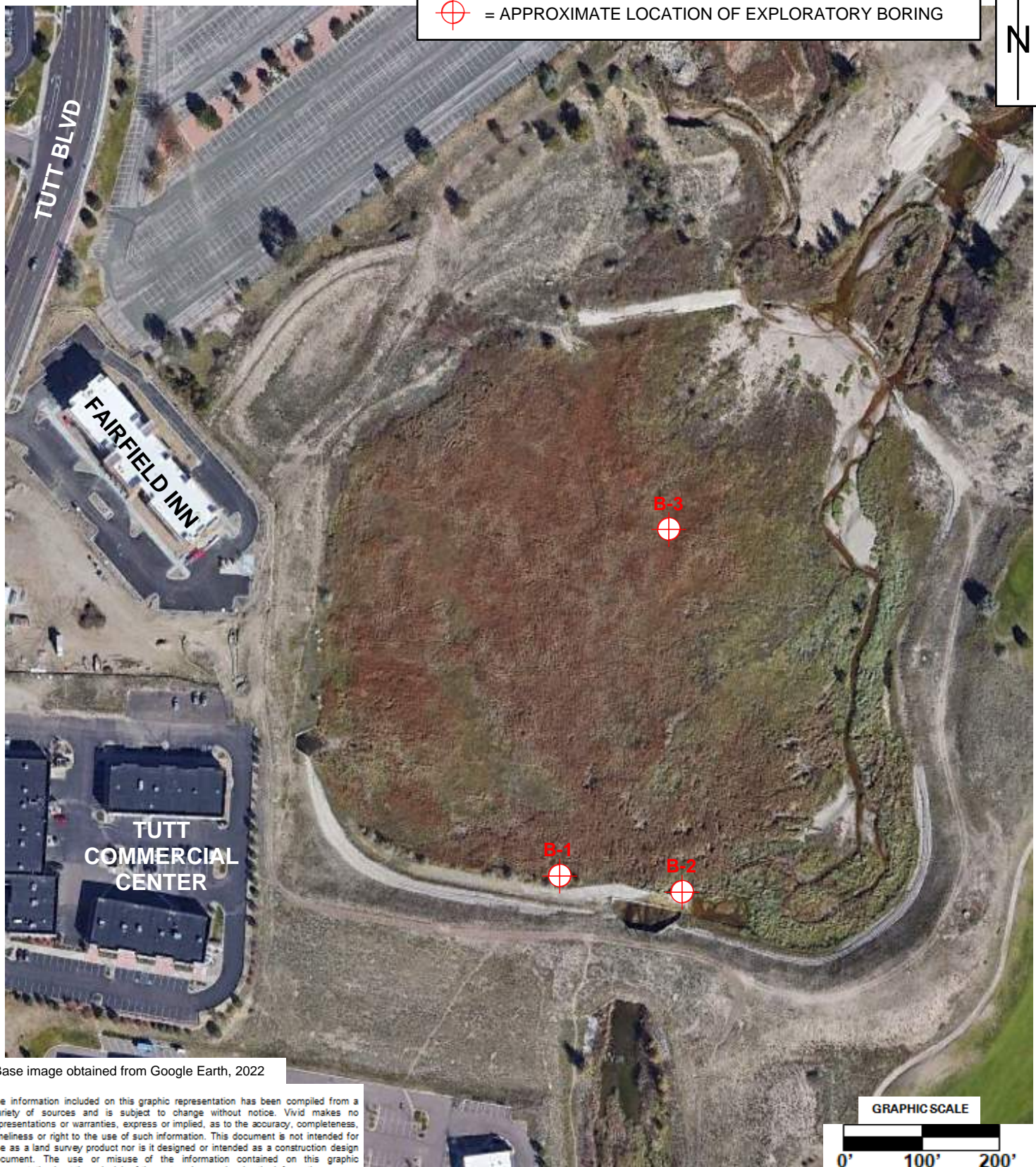

Base image obtained from Google Earth, 2022

The information included on this graphic representation has been compiled from a variety of sources and is subject to change without notice. Vivid makes no representations or warranties, express or implied, as to the accuracy, completeness, timeliness or right to the use of such information. This document is not intended for use as a land survey product nor is it designed or intended as a construction design document. The use or misuse of the information contained on this graphic representation is at the sole risk of the party using or misusing the information.

GRAPHIC SCALE

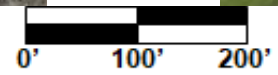

Project No: D21-2-389
Date: March 7, 2022
Drawn by: MBR
Reviewed by: BTM

BORING LOCATION PLAN

Proposed Sand Creek Pond No. 2 Improvements
 Vicinity of Barnes Road and Tutt Boulevard
 Colorado Springs, Colorado

Figure
2

Appendix A
Logs of Exploratory Borings



Vivid Engineering Group, Inc.
 1053 Elkton Drive
 Colorado Springs, Colorado 80907
 Telephone: 719-896-4356
 Fax: 719-8964357

KEY TO SYMBOLS

CLIENT Merrick & Company

PROJECT NAME Proposed Sand Creek Pond No. 2 Improvements

PROJECT NUMBER D21-2-389

PROJECT LOCATION Colorado Springs, Colorado

LITHOLOGIC SYMBOLS (Unified Soil Classification System)



CLAYSTONE



FILL



INTERBEDDED CLAYSTONE & SANDSTONE



MH: USCS Elastic Silt



SANDSTONE



SM: USCS Silty Sand



SP: USCS Poorly-graded Sand

SAMPLER SYMBOLS



Grab Sample



2" I.D. Modified California Sampler (MC)



Standard Penetration Test (SPT)

ABBREVIATIONS

- LL - LIQUID LIMIT (%)
- PI - PLASTIC INDEX (%)
- MC - MOISTURE CONTENT (%)
- DD - DRY DENSITY (PCF)
- NP - NON PLASTIC
- FINES- PERCENT PASSING NO. 200 SIEVE
- UCS - UNCONFINED COMPRESSIVE STRENGTH

Water Level at Time
Drilling, or as Shown

KEY TO SYMBOLS - GINT STD US LAB.GDT - 3/7/22 11:39 - C:\USERS\MARY BETH RAY\VIDE ENGINEERING GROUP\GEO - DOCUMENTS\PROJECTS_2021\D21-2-389_MERRICK_SAND CREEK POND NO. 2_GEO16 - DRAFTING\D21-2-389.GPJ



Vivid Engineering Group, Inc.
 1053 Elkton Drive
 Colorado Springs, Colorado 80907
 Telephone: 719-896-4356
 Fax: 719-8964357

BORING NUMBER B-1

PAGE 1 OF 1

CLIENT Merrick & Company
PROJECT NUMBER D21-2-389
DATE STARTED 1/13/22 **COMPLETED** 1/13/22
DRILLING CONTRACTOR VINE (CME-850)
DRILLING METHOD 8" Hollow Stem Auger
LOGGED BY M. Ray **CHECKED BY** B. Mustain
NOTES _____

PROJECT NAME Proposed Sand Creek Pond No. 2 Improvements
PROJECT LOCATION Colorado Springs, Colorado
GROUND ELEVATION _____ **HOLE SIZE** 8 inches
GROUND WATER LEVELS:
 ▽ **AT TIME OF DRILLING** 3.00 ft
AT END OF DRILLING ---
AFTER DRILLING ---

GENERAL BH / TP / WELL - MODIFIED - GINT STD US LAB.GDT - 3/7/22 11:31 - C:\USERS\MARY BETH RAY\VIDD ENGINEERING GROUP\GEO - DOCUMENTS\PROJECTS_2021\D21-2-389_MERRICK_SAND CREEK POND NO. 2_GEO16 - DRAFTING\ID21-2-389.GPJ

DEPTH (ft)	SAMPLE TYPE NUMBER	BLOW COUNTS (N VALUE)	TESTS	GRAPHIC LOG	MATERIAL DESCRIPTION
0					
0 - 5	GB		MC = 12.7% LL = 24 PL = 17 Fines = 13.0%		Existing Fill Silty, Clayey SAND, grayish-brown, wet, hard to very hard (possibly CTS material)
5 - 8	MC	50/6"	MC = 7.8% DD = 115.8 pcf		
8.0					----- Elastic SILT with sand, olive-brown, very moist to wet, stiff
8 - 10	MC	5-8	MC = 37.8% DD = 82.6 pcf LL = 71 PL = 35 Fines = 84.0%		
10 - 12					
12.0					Dawson Formation CLAYSTONE, dark gray, moist, hard
12 - 15	MC	50/8"	MC = 23.5% DD = 99.7 pcf UCS = 8,031 psf		
15 - 20	MC	50/9"			
20 - 21					- harder drilling at about 21 feet
21.0					Dawson Formation SANDSTONE, gray, moist, very hard
21 - 25	MC	50/4"			
25 - 29.4	MC	50/5"			

Bottom of borehole at 29.4 feet.

GENERAL BH / TP / WELL - MODIFIED - GINT STD US LAB.GDT - 3/7/22 11:31 - C:\USERS\MARY BETH RAY\VIVID ENGINEERING GROUP\GEO - DOCUMENTS\PROJECTS_2021\D21-2-389_MERRICK_SAND CREEK POND NO. 2_GEO\6 - DRAFTING\ID21-2-389.GPJ



Vivid Engineering Group, Inc.
 1053 Elkton Drive
 Colorado Springs, Colorado 80907
 Telephone: 719-896-4356
 Fax: 719-8964357

BORING NUMBER B-2

CLIENT Merrick & Company

PROJECT NUMBER D21-2-389

DATE STARTED 1/13/22 **COMPLETED** 1/13/22

DRILLING CONTRACTOR VINE (CME-850)

DRILLING METHOD 8" Hollow Stem Auger

LOGGED BY M. Ray **CHECKED BY** B. Mustain

NOTES _____

PROJECT NAME Proposed Sand Creek Pond No. 2 Improvements

PROJECT LOCATION Colorado Springs, Colorado

GROUND ELEVATION _____ **HOLE SIZE** 8 inches

GROUND WATER LEVELS:

 ▽ **AT TIME OF DRILLING** 8.00 ft

AT END OF DRILLING ---

AFTER DRILLING ---

DEPTH (ft)	SAMPLE TYPE NUMBER	BLOW COUNTS (N VALUE)	TESTS	GRAPHIC LOG	MATERIAL DESCRIPTION
0					
5	GB				Existing Fill Silty SAND, grayish-brown, moist to wet, hard to very hard (possibly CTS material)
8.0					Poorly Graded SAND with gravel, light brown, wet, medium dense
10	MC	9-9	MC = 29.1% DD = 93.1 pcf LL = NP PL = NP Fines = 3.9%		
14.0					Dawson Formation Clayey SANDSTONE, yellowish-brown to gray, moist, very hard
15	MC	10-15	UCS = 5396 psf		
20	MC	50/3"	MC = 16.7% DD = 113.6 pcf		
25	MC	50/6"			
29.3	MC	50/4"			Bottom of borehole at 29.3 feet.

GENERAL BH / TP / WELL - MODIFIED - GINT STD US LAB.GDT - 3/7/22 11:31 - C:\USERS\MARY BETH RAY\VIVID ENGINEERING GROUP\GEO - DOCUMENTS\PROJECTS_2021\ID21-2-389_MERRICK_SAND CREEK POND NO.2_GEO\16 - DRAFTING\ID21-2-389.GPJ



Vivid Engineering Group, Inc.
 1053 Elkton Drive
 Colorado Springs, Colorado 80907
 Telephone: 719-896-4356
 Fax: 719-8964357

BORING NUMBER B-3

CLIENT Merrick & Company	PROJECT NAME Proposed Sand Creek Pond No. 2 Improvements
PROJECT NUMBER D21-2-389	PROJECT LOCATION Colorado Springs, Colorado
DATE STARTED 1/13/22	COMPLETED 1/13/22
DRILLING CONTRACTOR VINE (CME-850)	GROUND ELEVATION _____ HOLE SIZE 8 inches
DRILLING METHOD 8" Hollow Stem Auger	GROUND WATER LEVELS:
LOGGED BY M. Ray	▽ AT TIME OF DRILLING 4.00 ft
CHECKED BY B. Mustain	AT END OF DRILLING ---
NOTES _____	AFTER DRILLING ---

DEPTH (ft)	SAMPLE TYPE NUMBER	BLOW COUNTS (N VALUE)	TESTS	GRAPHIC LOG	MATERIAL DESCRIPTION
0					
5	GB	3-3-4 (7)	MC = 36.8% LL = 31 PL = 24 Fines = 28.0%	▽	Silty SAND, light gray, brown, wet, loose
10	SPT	10-11-13 (24)		9.0	Dawson Formation Interbedded CLAYSTONE and SANDSTONE, gray, moist, hard to very hard
15	SPT	16-26-26 (52)			
20	MC	50/7"	MC = 25.2% DD = 97.6 pcf		
24.5	MC	50/6"		24.5	

Bottom of borehole at 24.5 feet.

Appendix B
Geotechnical Laboratory Test Results



Vivid Engineering Group, Inc.
 1053 Elkton Drive
 Colorado Springs, Colorado 80907
 Telephone: 719-896-4356
 Fax: 719-8964357

ATTERBERG LIMITS' RESULTS

CLIENT Merrick & Company

PROJECT NAME Proposed Sand Creek Pond No. 2 Improvements

PROJECT NUMBER D21-2-389

PROJECT LOCATION Colorado Springs, Colorado

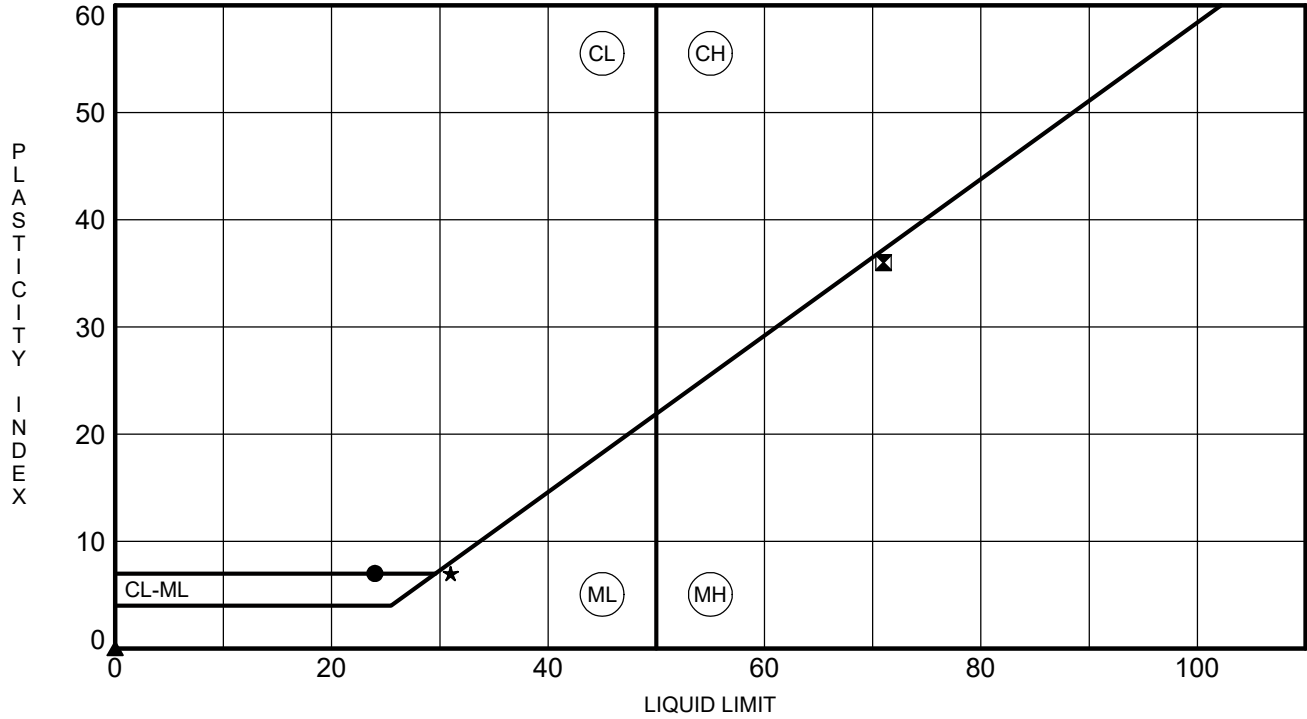

BOREHOLE	DEPTH	LL	PL	PI	Fines	Classification
● B-1	0-4'	24	17	7	13	SILTY, CLAYEY SAND(SC-SM)
☒ B-1	9.0	71	35	36	84	ELASTIC SILT with SAND(MH)
▲ B-2	9.0	NP	NP	NP	4	POORLY GRADED SAND with GRAVEL(SP)
★ B-3	4.0	31	24	7	28	SILTY SAND(SM)

ATTERBERG LIMITS - GINT STD US LAB.GDT - 3/7/22 12:13 - C:\USERS\MARY BETH RAY\VID ENGINEERING GROUP\GEO - DOCUMENTS\PROJECTS_2021\D21-2-389_MERRICK_SAND CREEK POND NO. 2_GEO16 - DRAFTING\D21-2-389.GPJ



Vivid Engineering Group, Inc.
 1053 Elkton Drive
 Colorado Springs, Colorado 80907
 Telephone: 719-896-4356
 Fax: 719-8964357

GRAIN SIZE DISTRIBUTION

CLIENT Merrick & Company

PROJECT NAME Proposed Sand Creek Pond No. 2 Improvements

PROJECT NUMBER D21-2-389

PROJECT LOCATION Colorado Springs, Colorado

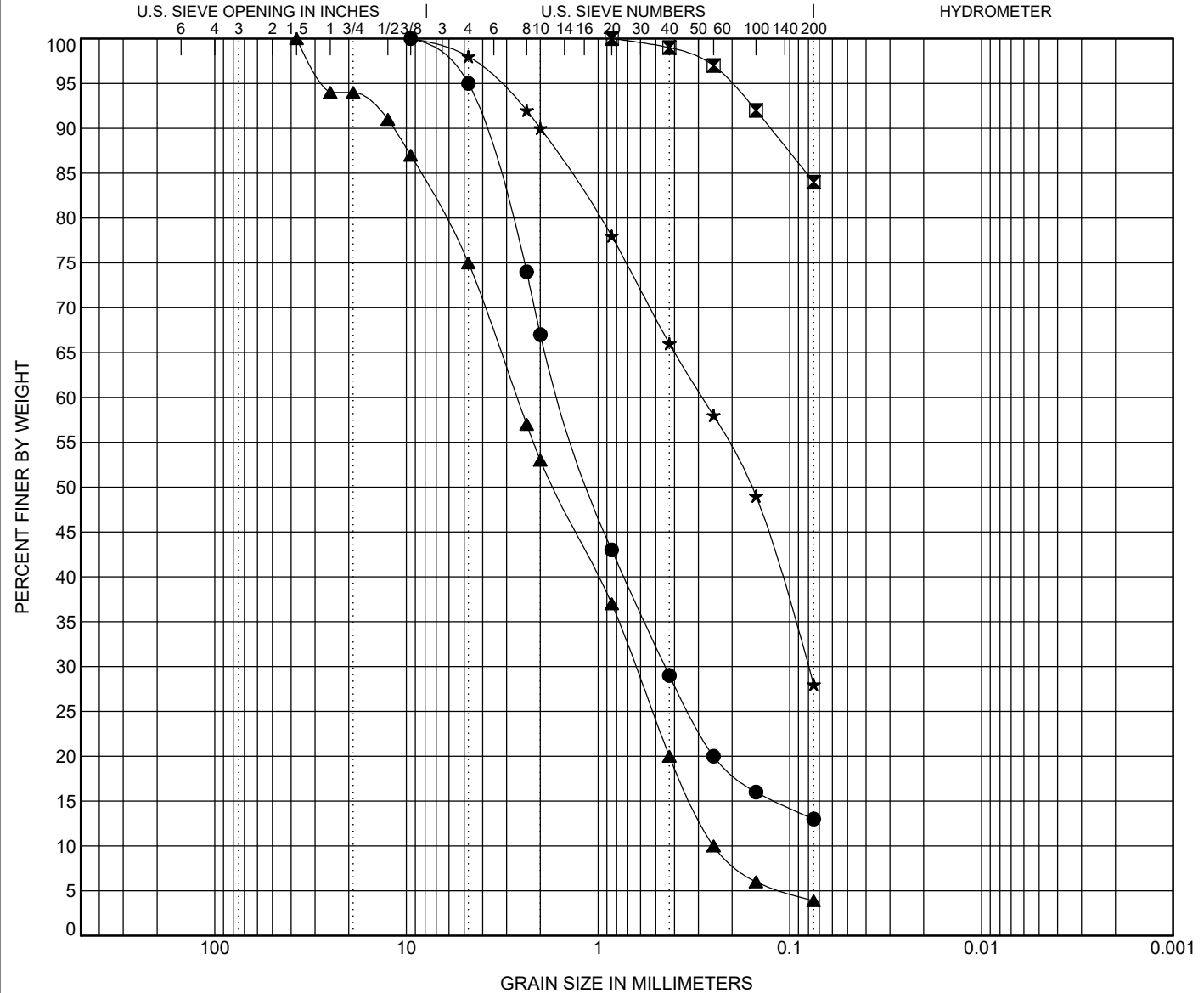

COBBLES	GRAVEL		SAND			SILT OR CLAY
	coarse	fine	coarse	medium	fine	

BOREHOLE	DEPTH	Classification	LL	PL	PI	Cc	Cu
● B-1	0-4'	SILTY, CLAYEY SAND(SC-SM)	24	17	7		
☒ B-1	9.0	ELASTIC SILT with SAND(MH)	71	35	36		
▲ B-2	9.0	POORLY GRADED SAND with GRAVEL(SP)	NP	NP	NP	0.62	10.61
★ B-3	4.0	SILTY SAND(SM)	31	24	7		

BOREHOLE	DEPTH	D100	D60	D30	D10	%Gravel	%Sand	%Silt	%Clay
● B-1	0-4'	9.5	1.558	0.447		5.0	82.0		13.0
☒ B-1	9.0	0.85				0.0	16.0		84.0
▲ B-2	9.0	37.5	2.652	0.639	0.25	25.0	71.1		3.9
★ B-3	4.0	9.5	0.285	0.08		2.0	70.0		28.0

GRAIN SIZE - GINT STD US LAB.GDT - 3/7/22 12:12 - C:\USERS\MARY BETH RAY\VID ENGINEERING GROUP\GEO - DOCUMENTS\PROJECTS_2021\D21-2-389_MERRICK SAND CREEK POND NO. 2_GEO\6 - DRAFTING\G21-2-389.GPJ



Vivid Engineering Group, Inc.
 1053 Elkton Drive
 Colorado Springs, Colorado 80907
 Telephone: 719-896-4356
 Fax: 719-8964357

SUMMARY OF LABORATORY RESULTS

PAGE 1 OF 1

CLIENT Merrick & Company

PROJECT NAME Proposed Sand Creek Pond No. 2 Improvements

PROJECT NUMBER D21-2-389

PROJECT LOCATION Colorado Springs, Colorado

Borehole	Depth	Liquid Limit	Plastic Limit	Plasticity Index	Maximum Size (mm)	%<#200 Sieve	Classification	Water Content (%)	Dry Density (pcf)		
B-1	0-4'	24	17	7	9.5	13	SC-SM	12.7			
B-1	4.0							7.8	115.8		
B-1	9.0	71	35	36	0.85	84	MH	37.8	82.6		
B-1	14.0							23.5	99.7		
B-2	9.0	NP	NP	NP	37.5	4	SP	29.1	93.1		
B-2	19.0							16.7	113.6		
B-3	4.0	31	24	7	9.5	28	SM	36.8			
B-3	19.0							25.2	97.6		

LAB SUMMARY - GINT STD US LAB.GDT - 3/7/22 12:03 - C:\USERS\MARY BETH RAY\VIVID ENGINEERING GROUP\GEO - DOCUMENTS\PROJECTS_2021\D21-2-389_MERRICK_SAND CREEK POND NO. 2_GEO16 - DRAFTING\D21-2-389.GPJ

UNCONFINED COMPRESSION TEST ASTM D 2166

PROJECT NAME: SAND CREEK POND No. 2
 PROJECT NO. : D21-2-389
 CLIENT NAME: Merrick & Company

PROJECT ENG.: BTM
 DATE RECEIVED: 1/14/2022
 DATE TESTED: 1/31/2022
 TESTED BY: TK
 DATA ENTRY: TK

BORING NO. : B-1
 SAMPLE NO.: 1
 DEPTH, FT. : 14ft
 TEST SPECIMEN NO.: 1

DESCRIPTION: CLAYSTONE, SANDY,
GRAYISH-BROWN, MOIST

INITIAL DATA

Avg. Height, In.: 4.047
 Avg. Diameter, In.: 1.930
 L/D Ratio: 2.1
 Moisture Content, %:
 (Sample, After test) 23.5
 Dry Density, pcf: 99.7
 Assumed Specific Gravity: 2.7
 Saturation, %: 91.9
 Void Ratio: 0.690
 Rate of Strain, %/Minute: 1.0

Compressive Strength @ Failure:
 Shear Strength @ Failure:
 Axial Strain @ Failure, %:

	PSF	PSI
Compressive Strength @ Failure:	8031	56
Shear Strength @ Failure:	4015	28
Axial Strain @ Failure, %:	3.5	3.5

Photo:

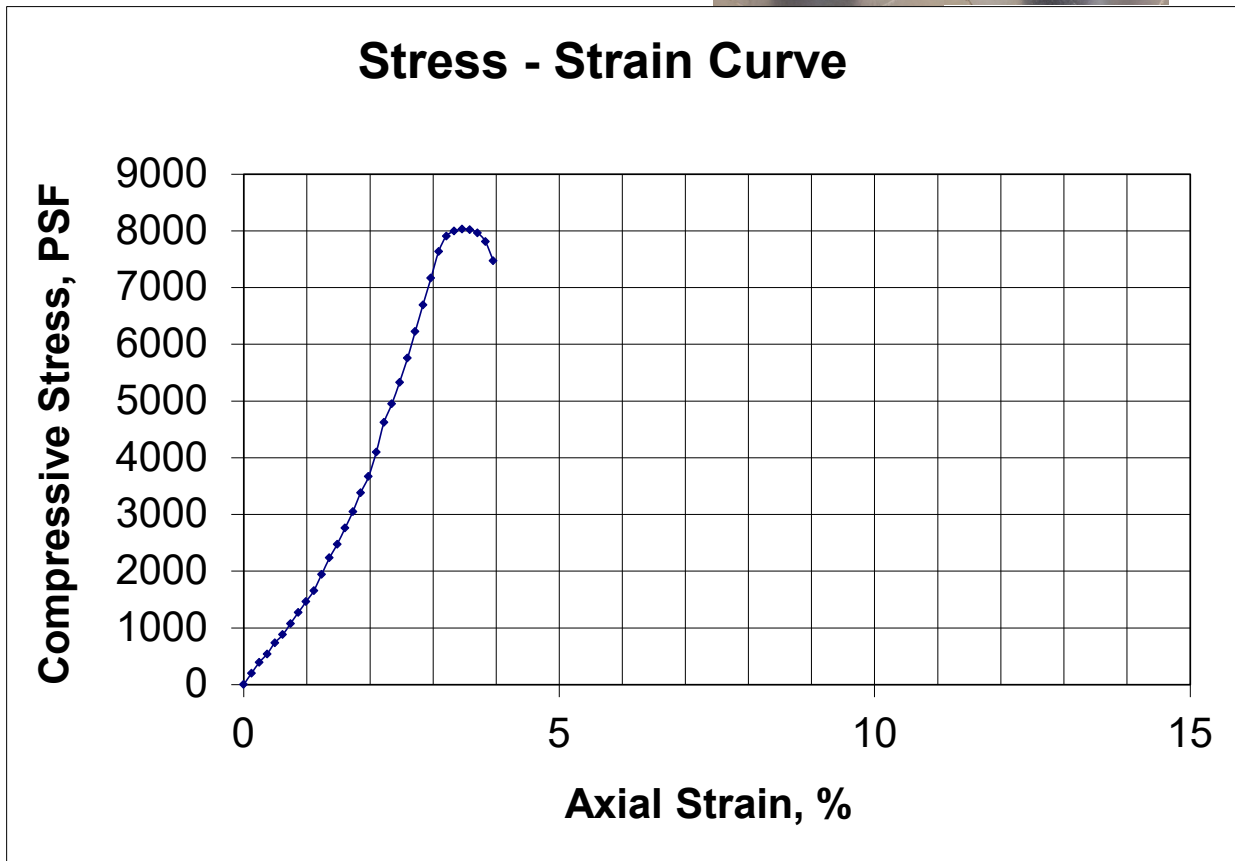
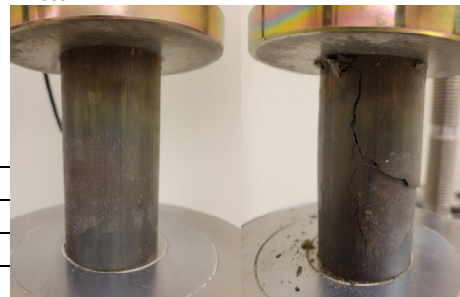

UNCONFINED COMPRESSION TEST ASTM D 2166

PROJECT NAME: SAND CREEK POND No. 2
 PROJECT NO. : D21-2-389
 CLIENT NAME: Merick & Company

PROJECT ENG.: BTM
 DATE RECEIVED: 1/14/2022
 DATE TESTED: 1/31/2022
 TESTED BY: TK
 DATA ENTRY: TK

BORING NO. : B-2
 SAMPLE NO.: 2
 DEPTH, FT. : 14ft
 TEST SPECIMEN NO.: 2

DESCRIPTION: CLAYEY SANDSTONE,
YELLOWISH-BROWN TO GRAY, MOIST

INITIAL DATA

Avg. Height, In.: 4.013
 Avg. Diameter, In.: 1.930
 L/D Ratio: 2.1
 Moisture Content, %:
 (Sample, After test) 29.1
 Dry Density, pcf: 93.1
 Assumed Specific Gravity: 2.7
 Saturation, %: 96.9
 Void Ratio: 0.810
 Rate of Strain, %/Minute: 1.0

Compressive Strength @ Failure:
 Shear Strength @ Failure:
 Axial Strain @ Failure, %:

	PSF	PSI
Compressive Strength @ Failure:	5396	37
Shear Strength @ Failure:	2698	19
Axial Strain @ Failure, %:	3.0	3.0

Photo:

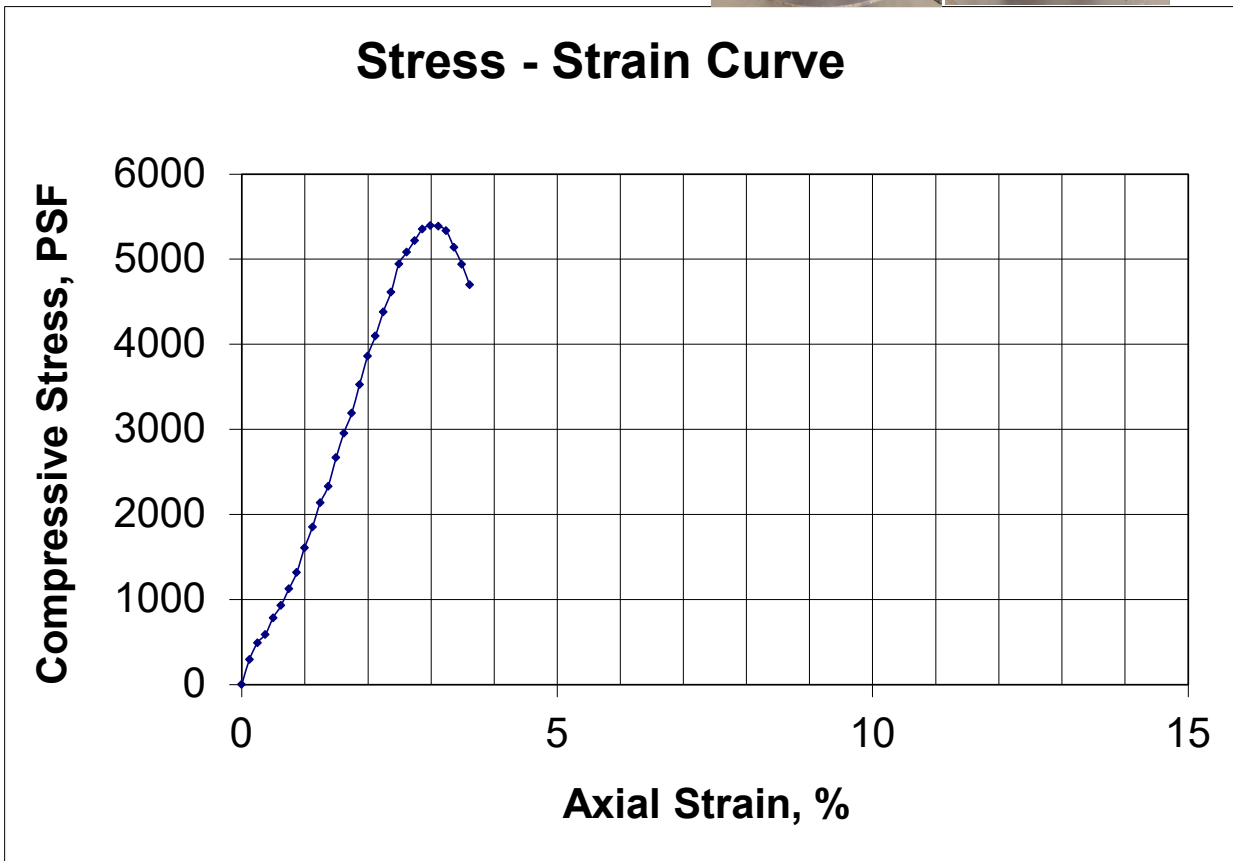
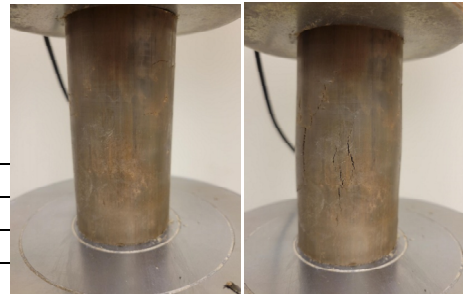

Appendix C
Analytical Laboratory Test Results

WELD LABORATORIES, INC.

1527 First Avenue • Greeley, Colorado 80631
Phone: (970) 353-8118 • Fax: (970) 353-1671
www.weldlabs.com

February 15, 2022

Vivid Engineering, Inc
Attn: Brysen Mustain
1053 Elkton Drive
Colorado Springs, CO 80907

Project No.: Sand Creek Pond 2 - D21-2-389
Sample ID: B-1 0-4'

Laboratory No.:	Results ^{1,3}	10-Point System ²
pH (SI) AASHTO T 289-91 (ASTM G51 available for some soil)	8.95	3
Conductivity (mmhos/cm)	0.380	NA
Resistivity (ohm-m) USDA Handbook 60, temperature corrected conductivity probe	26.32	
Minimum Lab Resistivity (ohm-cm)	2300	2
Minimum Lab Resistivity (ohm-m) via Miller Box, Tinker & Razor SR-2 (AASHTO T 288-12) ⁴	23	
Redox (mV vs. Ag/AgCl) ASTM G200 (ASTM D1498 if soil is low in moisture)	228	0
Free Sulfide (mg/kg DMB) Hach method 8131, prescreened with lead acetate paper	0.15	3.5
Chloride (mg/kg DMB) AASHTO T 291-94	160	2
Sulfate (mg/kg DMB) CP-L 2103	524	2
Sulfate (% DMB)	0.0524	
Sulfate-S (mg/kg DMB)	174.7	

1. NA = Not Analyzed or Not Applicable. DMB = Dry Matter Basis. Measurements taken at 25°C.

2. 10-point Corrosion system based on: Appendix A of ANSI/AWWA C105/A21.5 Standard "Polyethylene Encasement for Ductile Iron Pipe Systems." The Cl- points based on [Cl-] in "Nature: Scientific Reports Volume 7, Article number: 6865 (2017)" Sulfate is penalized at half the rate of chloride: A. A. Sagúés et. al. (<https://rosap.nrl.bts.gov/view/dot/17493>)

3. pH, Conductivity, and Redox are generally read on a 1:1 soil:water mixture if the soil is dry.

4. ASTM G57 4-Electrode Method used unless 2-electrode method is requested.

Project Manager

2-15-22
Date

WELD LABORATORIES, INC.

1527 First Avenue • Greeley, Colorado 80631
Phone: (970) 353-8118 • Fax: (970) 353-1671
www.weldlabs.com

February 15, 2022

Vivid Engineering, Inc
Attn: Brysen Mustain
1053 Elkton Drive
Colorado Springs, CO 80907

Project No.: Sand Creek Pond 2 - D21-2-389

Sample ID: B-3 14'

Laboratory No.: E22023-2B

	Results ^{1,3}	10-Point System ²
pH (SI) AASHTO T 289-91 (ASTM G51 available for some soil)	7.6	0
Conductivity (mmhos/cm)	0.807	NA
Resistivity (ohm-m) USDA Handbook 60, temperature corrected conductivity probe	12.40	
Minimum Lab Resistivity (ohm-cm)	1200	10
Minimum Lab Resistivity (ohm-m) via Miller Box, Tinker & Razor SR-2 (AASHTO T 288-12) ⁴	12	
Redox (mV vs. Ag/AgCl) ASTM G200 (ASTM D1498 if soil is low in moisture)	214	0
Free Sulfide (mg/kg DMB) Hach method 8131, prescreened with lead acetate paper	< 1	0
Chloride (mg/kg DMB) AASHTO T 291-94	89	1
Sulfate (mg/kg DMB) CP-L 2103	1079	2
Sulfate (% DMB)	0.1079	
Sulfate-S (mg/kg DMB)	359.7	

1. NA = Not Analyzed or Not Applicable. DMB = Dry Matter Basis. Measurements taken at 25°C.

2. 10-point Corrosion system based on: Appendix A of ANSI/AWWA C105/A21.5 Standard "Polyethylene Encasement for Ductile Iron Pipe Systems." The Cl- points based on [Cl-] in "Nature: Scientific Reports Volume 7, Article number: 6865 (2017)"
Sulfate is penalized at half the rate of chloride: A. A. Sagúés et. al. (<https://rosap.nrl.bts.gov/view/dot/17493>)

3. pH, Conductivity, and Redox are generally read on a 1:1 soil:water mixture if the soil is dry.

4. ASTM G57 4-Electrode Method used unless 2-electrode method is requested.

Project Manager

2-15-22
Date

Appendix D

Site Photos



DRILLING BORING B-1 - LOOKING EAST - JANUARY 2022



DRILLING BORING B-3 - LOOKING NORTH - JANUARY 2022



Project No: D21-2-389
 Date: 3/7/2022
 Drawn by: MBR
 Reviewed by: BTM

SITE PHOTOS

Proposed Sand Creek Pond No. 2 Improvements
 Vicinity of Barnes Road and Tutt Boulevard
 Colorado Springs, Colorado

FIGURE

D-1

26 of 507



EXISTING POND AREA - LOOKING EAST - AUGUST 2021



EXISTING OUTLET STRUCTURE - LOOKING SOUTHWEST - AUGUST 2021



Project No: D21-2-389
 Date: 3/7/2022
 Drawn by: MBR
 Reviewed by: BTM

SITE PHOTOS

Proposed Sand Creek Pond No. 2 Improvements
 Vicinity of Barnes Road and Tutt Boulevard
 Colorado Springs, Colorado

FIGURE

D-2

262 of 507

Appendix E

Important Information About This Geotechnical Engineering Report

Important Information about This

Geotechnical-Engineering Report

Subsurface problems are a principal cause of construction delays, cost overruns, claims, and disputes.

While you cannot eliminate all such risks, you can manage them. The following information is provided to help.

The Geoprofessional Business Association (GBA) has prepared this advisory to help you – assumedly a client representative – interpret and apply this geotechnical-engineering report as effectively as possible. In that way, clients can benefit from a lowered exposure to the subsurface problems that, for decades, have been a principal cause of construction delays, cost overruns, claims, and disputes. If you have questions or want more information about any of the issues discussed below, contact your GBA-member geotechnical engineer. Active involvement in the Geoprofessional Business Association exposes geotechnical engineers to a wide array of risk-confrontation techniques that can be of genuine benefit for everyone involved with a construction project.

Geotechnical-Engineering Services Are Performed for Specific Purposes, Persons, and Projects

Geotechnical engineers structure their services to meet the specific needs of their clients. A geotechnical-engineering study conducted for a given civil engineer will not likely meet the needs of a civil-works constructor or even a different civil engineer. Because each geotechnical-engineering study is unique, each geotechnical-engineering report is unique, prepared *solely* for the client. *Those who rely on a geotechnical-engineering report prepared for a different client can be seriously misled.* No one except authorized client representatives should rely on this geotechnical-engineering report without first conferring with the geotechnical engineer who prepared it. *And no one – not even you – should apply this report for any purpose or project except the one originally contemplated.*

Read this Report in Full

Costly problems have occurred because those relying on a geotechnical-engineering report did not read it *in its entirety*. Do not rely on an executive summary. Do not read selected elements only. *Read this report in full.*

You Need to Inform Your Geotechnical Engineer about Change

Your geotechnical engineer considered unique, project-specific factors when designing the study behind this report and developing the confirmation-dependent recommendations the report conveys. A few typical factors include:

- the client's goals, objectives, budget, schedule, and risk-management preferences;
- the general nature of the structure involved, its size, configuration, and performance criteria;
- the structure's location and orientation on the site; and
- other planned or existing site improvements, such as retaining walls, access roads, parking lots, and underground utilities.

Typical changes that could erode the reliability of this report include those that affect:

- the site's size or shape;
- the function of the proposed structure, as when it's changed from a parking garage to an office building, or from a light-industrial plant to a refrigerated warehouse;
- the elevation, configuration, location, orientation, or weight of the proposed structure;
- the composition of the design team; or
- project ownership.

As a general rule, *always* inform your geotechnical engineer of project changes – even minor ones – and request an assessment of their impact. *The geotechnical engineer who prepared this report cannot accept responsibility or liability for problems that arise because the geotechnical engineer was not informed about developments the engineer otherwise would have considered.*

This Report May Not Be Reliable

Do not rely on this report if your geotechnical engineer prepared it:

- for a different client;
- for a different project;
- for a different site (that may or may not include all or a portion of the original site); or
- before important events occurred at the site or adjacent to it; e.g., man-made events like construction or environmental remediation, or natural events like floods, droughts, earthquakes, or groundwater fluctuations.

Note, too, that it could be unwise to rely on a geotechnical-engineering report whose reliability may have been affected by the passage of time, because of factors like changed subsurface conditions; new or modified codes, standards, or regulations; or new techniques or tools. *If your geotechnical engineer has not indicated an “apply-by” date on the report, ask what it should be, and, in general, if you are the least bit uncertain about the continued reliability of this report, contact your geotechnical engineer before applying it.* A minor amount of additional testing or analysis – if any is required at all – could prevent major problems.

Most of the “Findings” Related in This Report Are Professional Opinions

Before construction begins, geotechnical engineers explore a site's subsurface through various sampling and testing procedures. *Geotechnical engineers can observe actual subsurface conditions only at those specific locations where sampling and testing were performed.* The data derived from that sampling and testing were reviewed by your geotechnical engineer, who then applied professional judgment to form opinions about subsurface conditions throughout the site. Actual sitewide-subsurface conditions may differ – maybe significantly – from those indicated in this report. Confront that risk by retaining your geotechnical engineer to serve on the design team from project start to project finish, so the individual can provide informed guidance quickly, whenever needed.

This Report's Recommendations Are Confirmation-Dependent

The recommendations included in this report – including any options or alternatives – are confirmation-dependent. In other words, *they are not final*, because the geotechnical engineer who developed them relied heavily on judgment and opinion to do so. Your geotechnical engineer can finalize the recommendations *only after observing actual subsurface conditions* revealed during construction. If through observation your geotechnical engineer confirms that the conditions assumed to exist actually do exist, the recommendations can be relied upon, assuming no other changes have occurred. *The geotechnical engineer who prepared this report cannot assume responsibility or liability for confirmation-dependent recommendations if you fail to retain that engineer to perform construction observation.*

This Report Could Be Misinterpreted

Other design professionals' misinterpretation of geotechnical-engineering reports has resulted in costly problems. Confront that risk by having your geotechnical engineer serve as a full-time member of the design team, to:

- confer with other design-team members,
- help develop specifications,
- review pertinent elements of other design professionals' plans and specifications, and
- be on hand quickly whenever geotechnical-engineering guidance is needed.

You should also confront the risk of constructors misinterpreting this report. Do so by retaining your geotechnical engineer to participate in prebid and preconstruction conferences and to perform construction observation.

Give Constructors a Complete Report and Guidance

Some owners and design professionals mistakenly believe they can shift unanticipated-subsurface-conditions liability to constructors by limiting the information they provide for bid preparation. To help prevent the costly, contentious problems this practice has caused, include the complete geotechnical-engineering report, along with any attachments or appendices, with your contract documents, *but be certain to note conspicuously that you've included the material for informational purposes only*. To avoid misunderstanding, you may also want to note that "informational purposes" means constructors have no right to rely on the interpretations, opinions, conclusions, or recommendations in the report, but they may rely on the factual data relative to the specific times, locations, and depths/elevations referenced. Be certain that constructors know they may learn about specific project requirements, including options selected from the report, *only* from the design drawings and specifications. Remind constructors that they may

perform their own studies if they want to, and *be sure to allow enough time* to permit them to do so. Only then might you be in a position to give constructors the information available to you, while requiring them to at least share some of the financial responsibilities stemming from unanticipated conditions. Conducting prebid and preconstruction conferences can also be valuable in this respect.

Read Responsibility Provisions Closely

Some client representatives, design professionals, and constructors do not realize that geotechnical engineering is far less exact than other engineering disciplines. That lack of understanding has nurtured unrealistic expectations that have resulted in disappointments, delays, cost overruns, claims, and disputes. To confront that risk, geotechnical engineers commonly include explanatory provisions in their reports. Sometimes labeled "limitations," many of these provisions indicate where geotechnical engineers' responsibilities begin and end, to help others recognize their own responsibilities and risks. *Read these provisions closely*. Ask questions. Your geotechnical engineer should respond fully and frankly.

Geoenvironmental Concerns Are Not Covered

The personnel, equipment, and techniques used to perform an environmental study – e.g., a "phase-one" or "phase-two" environmental site assessment – differ significantly from those used to perform a geotechnical-engineering study. For that reason, a geotechnical-engineering report does not usually relate any environmental findings, conclusions, or recommendations; e.g., about the likelihood of encountering underground storage tanks or regulated contaminants. *Unanticipated subsurface environmental problems have led to project failures*. If you have not yet obtained your own environmental information, ask your geotechnical consultant for risk-management guidance. As a general rule, *do not rely on an environmental report prepared for a different client, site, or project, or that is more than six months old*.

Obtain Professional Assistance to Deal with Moisture Infiltration and Mold

While your geotechnical engineer may have addressed groundwater, water infiltration, or similar issues in this report, none of the engineer's services were designed, conducted, or intended to prevent uncontrolled migration of moisture – including water vapor – from the soil through building slabs and walls and into the building interior, where it can cause mold growth and material-performance deficiencies. Accordingly, *proper implementation of the geotechnical engineer's recommendations will not of itself be sufficient to prevent moisture infiltration*. Confront the risk of moisture infiltration by including building-envelope or mold specialists on the design team. *Geotechnical engineers are not building-envelope or mold specialists*.



Telephone: 301/565-2733

e-mail: info@geoprofessional.org www.geoprofessional.org

Copyright 2016 by Geoprofessional Business Association (GBA). Duplication, reproduction, or copying of this document, in whole or in part, by any means whatsoever, is strictly prohibited, except with GBA's specific written permission. Excerpting, quoting, or otherwise extracting wording from this document is permitted only with the express written permission of GBA, and only for purposes of scholarly research or book review. Only members of GBA may use this document or its wording as a complement to or as an element of a report of any kind. Any other firm, individual, or other entity that so uses this document without being a GBA member could be committing negligent



VIVID Engineering Group, Inc.

1053 Elkton Drive, Colorado Springs, CO 80907

October 6, 2021

Theresa Ring, PE
Civil Water Engineer
Merrick & Company
theresa.ring@merrick.com

Subject: Non-Destructive/Visual Evaluation of Existing Soil-Cement Drop Structure Conditions
Location: Sand Creek Pond No. 2, Vicinity of Barnes Road and Tutt Boulevard, Colorado Springs, CO
Project No: D21-2-389

Dear Ms. Ring:

Vivid Engineering Group, Inc. (VIVID) recently performed a non-destructive/visual evaluation of the existing soil-cement drop structure located along Sand Creek, near the existing Sand Creek Pond No. 2 in the vicinity of Barnes Road and Tutt Boulevard in Colorado Springs, as described in our scope/fee proposal, dated February 17, 2021.

The following letter presents a summary of our evaluation as well as conclusions and recommendations.

BACKGROUND

Our understanding of the existing soil-cement drop structure was derived from our discussions with Merrick personnel, our on-site visual evaluation, and design details and sections developed by Kiowa Engineering, dated October 2009, provided by Merrick. We understand the existing drop structure may potentially be rehabilitated/repared as part of the larger Sand Creek Pond No. 2 improvements project.

DESIGN INFORMATION AND SITE EVALUATION

The following documents were provided by Merrick and reviewed as part of this evaluation:

- Details & Sections, Drop Structure Sta. 32+70, Sand Creek Detention Basin No. 2, design by Kiowa Engineering, October 2009.
- Various photographs of the site taken recently and provided via e-mail.

Based on review of the above information the following points are highlighted:

- The soil-cement drop structure was designed to be constructed with 12-inch thick (maximum) lifts of compacted soil cement.

- The presence of any cut-off walls could not be determined and were not included or shown in the design plans.
- Drop structure subgrade preparation requirements and specifications were not included and are unknown.

SITE INVESTIGATION

Visual Evaluation

On August 25, 2021 VIVID and Merrick personnel performed a visual and non-destructive observation of the existing drop structure conditions. Obvious areas of deterioration were the primary focus of the evaluation, and included the following major areas of observed distress:

- Undercutting and erosion of the upstream side of the drop structure crest to a depth of at least 12 inches and laterally underneath the crest at least 12 inches within the low-flow channel area;
- Erosion of the low-flow channel on the drop structure crest leading into the pool area;
- Erosion and undercutting (on the order of 6 to 12 inches) laterally into the drop structure on the side walls;
- Erosion “notch” and head-cutting feature on the drop/toe structure.

Figure 1, attached to this report, presents a summary of the general locations of the deterioration observed. This figure also references photos of the distress that are presented in Attachment A.

CONCLUSIONS AND RECOMMENDATIONS

Our evaluation found no obvious evidence of catastrophic failure or complete undermining of the structure due to the crest erosion and undercutting. Although the surface of the drop structure was observed to be severely eroded due to freeze/thaw cycles, surface water flows and sediment transport, the soil-cement surfaces downstream of the crest appeared largely in-tact and no areas of settlement or large fractures were observed. Portions of the crest and sidewalls have eroded or “flaked” away causing a lowering of the low-flow channel elevation, as well as causing locations where the sidewalls have small erosion features developing where it appears that water circulates and undercuts the sidewall lifts.

The primary structural concern is the undercutting and erosion of the crest area, where creek in-flows have continually eroded-out the channel subgrade materials and soil-cement crest. Based on t-probe investigations, the undercutting extends at least 12 inches laterally under the crest. To prevent additional undercutting, erosion and potential loss of subgrade support for other components of the drop structure, consideration should be given for installation of a driven sheet-pile or reinforced concrete cut-off wall within the creek channel (upstream of the crest) to mitigate the undercutting and direct water flow over the top of the crest. Additional repair considerations to the crest of the drop structure may include placing a new layer of concrete on top of the crest, and optionally over the front face of the top lift of soil-cement. These repairs would need to be structurally-connected by dowels or similar to a new cut-off wall to re-establish the crest elevation. Voids that are present due to undercutting may be filled-in with a high-strength flow-fill (if a driven sheet pile is used) or with high-strength, high-slump concrete if a concrete cut-off wall is constructed. The cut-off wall structure may be used as a “form” to retain and direct concrete/flow-fill materials into the voids under the crest. A conceptual schematic of the repair options is presented as Attachment B.

Other areas of surface erosion, undercutting in the sidewalls, and head-cutting near the toe were observed. Due to the nature of the soil-cement and its susceptibility to future erosion, any repairs or procedures to prevent additional erosion at the crest, sidewalls, and low-flow channel over the toe will require being structurally connected by dowels or similar using grout, epoxy or other adhesives, as appropriate.

CLOSING

We appreciate this opportunity to serve you, and we look forward to working with you again. Should you have any questions concerning this report, please contact the undersigned at 719.896.4356.

Sincerely,



Brysen T. Mustain, PG
Engineering Geologist



William J. Barreire, PE
Senior Geotechnical Engineer

Attachments:

- Figure 1 – Existing Drop Structure – Aerial Photo**
- A – Site Photos**
- B – Soil-Cement Drop Structure Conceptual Repairs Schematic**

Figure 1

Existing Drop Structure – Aerial Photo

ATTACHMENT A PHOTOS

PHOTO AREA 1

PHOTO AREA 2

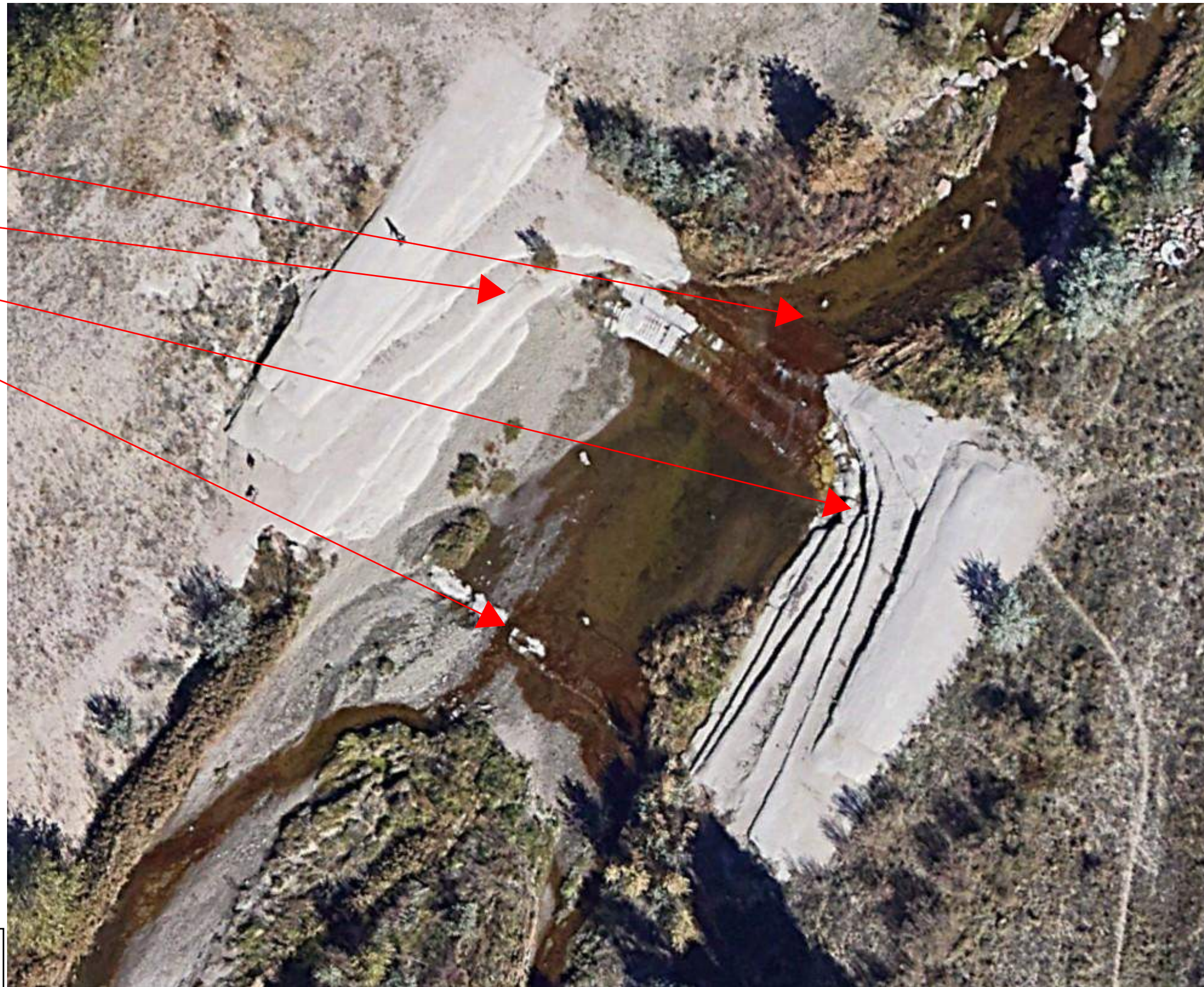
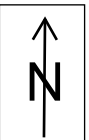

PHOTO AREAS 3 & 4

PHOTO AREA 5



The information included on this graphic representation has been compiled from a variety of sources and is subject to change without notice. Vivid makes no representations or warranties, express or implied, as to the accuracy, completeness, timeliness or right to the use of such information. This document is not intended for use as a land survey product nor is it designed or intended as a construction design document. The use or misuse of the information contained on this graphic representation is at the sole risk of the party using or misusing the information.

Not to Scale. Base image dated 10/19/2018 and obtained from Google Earth, 2021.

VIVID Engineering Group, Inc.
1053 Elkton Drive
Colorado Springs, Colorado 80907
719.896.4356

Project No: D21-2-389
Date: September 12, 2021
Drawn by: BTM
Reviewed by: WJB

EXISTING DROP STRUCTURE - AERIAL PHOTO
Sand Creek Pond No. 2 Improvements Vicinity of Barnes Road and Tutt Boulevard Colorado Springs, Colorado

Figure
1
270 of 507

Attachment A

Site Photos



PHOTO AREA 1 - EROSION AND UNDERCUTTING AT HEADWALL/CREST - LOOKING EAST

	Project No: D21-2-389	SITE PHOTOS	FIGURE A-1 272 of 507
	Date: 9/13/2021		
	Drawn by: BTM		
	Reviewed by: WJB		



PHOTO AREA 2 - UNDERCUTTING OF WEST SIDE WALL - LOOKING NORTHWEST



PHOTO AREA 3 - UNDERCUTTING OF EAST SIDEWALL - LOOKING EAST



Project No: D21-2-389
 Date: 9/13/2021
 Drawn by: BTM
 Reviewed by: WJB

SITE PHOTOS
 Sand Creek Pond No. 2 Improvements
 Vicinity of Barnes Road and Tutt Boulevard
 Colorado Springs, Colorado

FIGURE
A-2
 278 of 507



PHOTO AREA 4 - EXISTING CONDITIONS OF EAST SIDEWALL - LOOKING EAST



Project No:	D21-2-389
Date:	9/13/2021
Drawn by:	BTM
Reviewed by:	WJB

SITE PHOTOS
Sand Creek Pond No. 2 Improvements Vicinity of Barnes Road and Tutt Boulevard Colorado Springs, Colorado

FIGURE
A-3
27 of 507



PHOTO AREA 5 - EROSION/HEADCUT FEATURE AT TOE - LOOKING EAST



EXISTING DROP STRUCTURE - LOOKING NORTH

	Project No: D21-2-389	SITE PHOTOS	FIGURE A-4 275 of 507
	Date: 9/13/2021		
	Drawn by: BTM	Sand Creek Pond No. 2 Improvements Vicinity of Barnes Road and Tutt Boulevard Colorado Springs, Colorado	
	Reviewed by: WJB		

Attachment B

Soil-Cement Drop Structure Conceptual Repairs Schematic

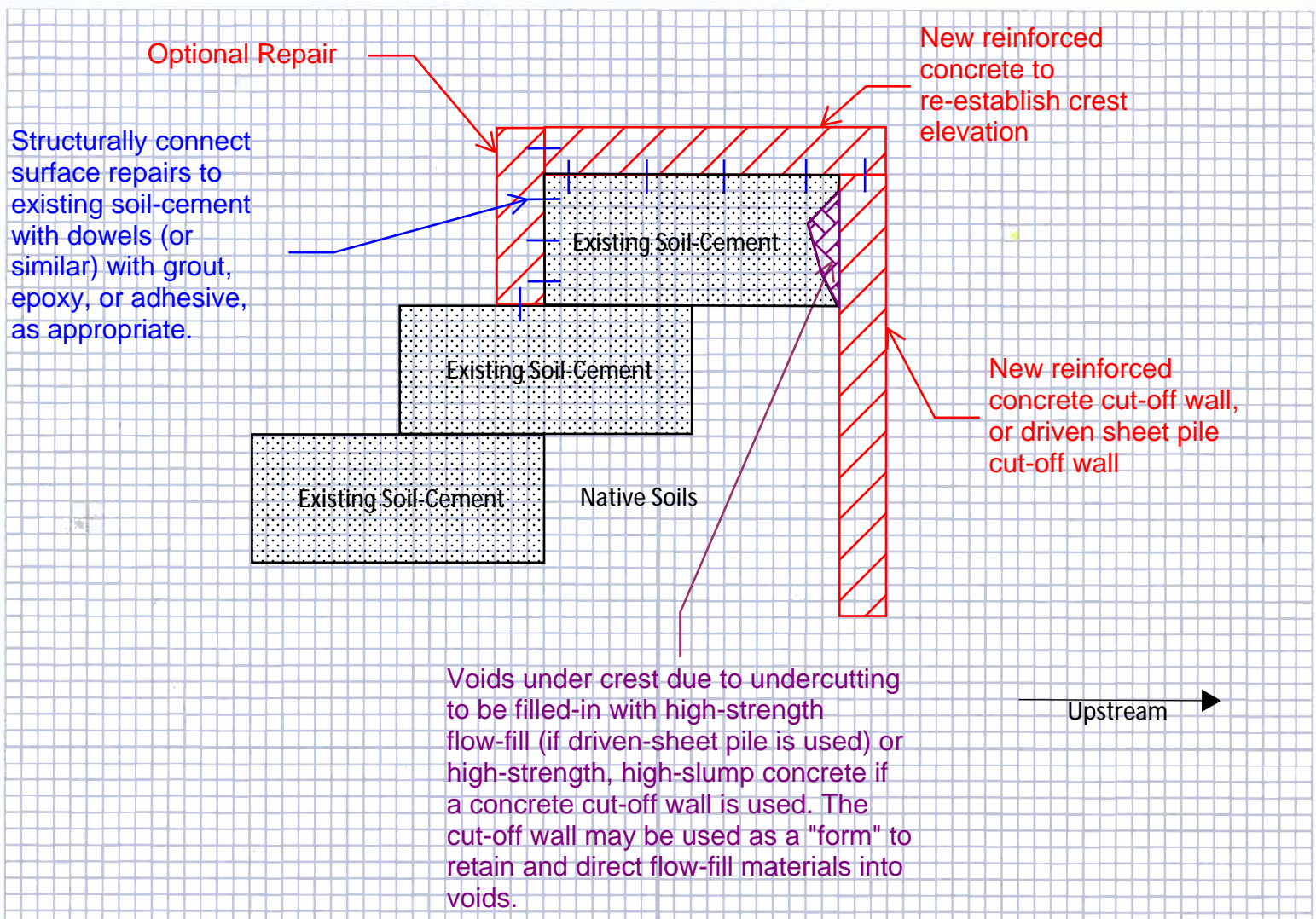

Note: If desired, "colored" concrete may be considered for use of the new surficial repairs in order to aesthetically match the existing soil-cement appearance.

NTS

APPENDIX C – GEC Administrator Certification



APPENDIX D – Hydraulic Calculations



Main Channel

Project Description

Friction Method	Manning Formula
Solve For	Discharge

Input Data

Channel Slope	0.003 ft/ft
Normal Depth	24.0 in

Section Definitions

Station (ft)	Elevation (ft)
0+00.0	2.00
0+08.0	0.00
0+12.5	0.00
0+33.5	0.00
0+38.0	0.00
0+46.0	2.00

Roughness Segment Definitions

Start Station	Ending Station	Roughness Coefficient
(0+00.0, 2.00)	(0+12.5, 0.00)	0.070
(0+12.5, 0.00)	(0+33.5, 0.00)	0.035
(0+33.5, 0.00)	(0+46.0, 2.00)	0.070

Options

Current Roughness Weighted Method	Lotter's Method
Open Channel Weighting Method	Lotter's Method
Closed Channel Weighting Method	Pavlovskii's Method

Results

Discharge	202.93 cfs
Elevation Range	0.0 to 2.0 ft
Flow Area	76.0 ft ²
Wetted Perimeter	46.5 ft
Hydraulic Radius	19.6 in
Top Width	46.00 ft
Normal Depth	24.0 in
Critical Depth	12.8 in
Critical Slope	0.027 ft/ft
Velocity	2.67 ft/s
Velocity Head	0.11 ft
Specific Energy	2.11 ft
Froude Number	0.366
Flow Type	Subcritical

Relevant Criteria:
Colorado Springs Drainage Criteria Manual, Volume 1, Table 12-3 for non-cohesive soils

Table 12-3. Hydraulic Design Criteria for Natural Unlined Channels

Design Parameter	Erosive Soils or Poor Vegetation	Erosion Resistant Soils and Vegetation
Maximum Low-flow Velocity (ft/sec)	3.5 ft/sec	5.0 ft/sec
Maximum 100-year Velocity (ft/sec)	5.0 ft/sec	7.0 ft/sec
Froude No., Low-flow	0.5	0.7
Froude No., 100-year	0.6	0.8
Maximum Tractive Force, 100-year	0.60 lb/sf	1.0 lb/sf

¹ Velocities, Froude numbers and tractive force values listed are average values for the cross section.
² "Erosion resistant" soils are those with 30% or greater clay content. Soils with less than 30% clay content shall be considered "erosive soils."

GVF Input Data

Downstream Depth	0.0 in
Length	0.0 ft

Main Channel

GVF Input Data

Number Of Steps	0
-----------------	---

GVF Output Data

Upstream Depth	0.0 in
Profile Description	N/A
Profile Headloss	0.00 ft
Downstream Velocity	0.00 ft/s
Upstream Velocity	0.00 ft/s
Normal Depth	24.0 in
Critical Depth	12.8 in
Channel Slope	0.003 ft/ft
Critical Slope	0.027 ft/ft

Messages

Messages	Resulted weighted roughness is less than any individual roughness. Consider using Improved Lotters weighted roughness method.
----------	---

Sand Creek Main Channel Riffles

Project Description

Friction Method	Manning Formula
Solve For	Normal Depth

Input Data

Channel Slope	0.020 ft/ft
Discharge	200.00 cfs

Section Definitions

Station (ft)	Elevation (ft)
0+00.0	2.00
0+08.0	0.00
0+12.5	0.00
0+33.5	0.00
0+38.0	0.00
0+46.0	2.00

Roughness Segment Definitions

Start Station	Ending Station	Roughness Coefficient
(0+00.0, 2.00)	(0+12.5, 0.00)	0.070
(0+12.5, 0.00)	(0+33.5, 0.00)	0.035
(0+33.5, 0.00)	(0+46.0, 2.00)	0.070

Options

Current Roughness Weighted Method	Lotter's Method
Open Channel Weighting Method	Lotter's Method
Closed Channel Weighting Method	Pavlovskii's Method

Results

Normal Depth	13.8 in
Elevation Range	0.0 to 2.0 ft
Flow Area	39.6 ft ²
Wetted Perimeter	39.5 ft
Hydraulic Radius	12.1 in
Top Width	39.17 ft
Normal Depth	13.8 in
Critical Depth	12.7 in
Critical Slope	0.026 ft/ft
Velocity	5.04 ft/s
Velocity Head	0.40 ft
Specific Energy	1.54 ft
Froude Number	0.884
Flow Type	Subcritical

**RIFFLES WILL BE LINED WITH TYPE
M VOID-PERMEATED RIPRAP**

GVF Input Data

Downstream Depth	0.0 in
Length	0.0 ft

Sand Creek Main Channel Riffles

GVF Input Data

Number Of Steps	0
-----------------	---

GVF Output Data

Upstream Depth	0.0 in
Profile Description	N/A
Profile Headloss	0.00 ft
Downstream Velocity	0.00 ft/s
Upstream Velocity	0.00 ft/s
Normal Depth	13.8 in
Critical Depth	12.7 in
Channel Slope	0.020 ft/ft
Critical Slope	0.026 ft/ft

Messages

Messages	Resulted weighted roughness is less than any individual roughness. Consider using Improved Lotters weighted roughness method.
----------	---

Between Drop Structure and Flow Spreader

Project Description	
Friction Method	Manning Formula
Solve For	Normal Depth
Input Data	
Roughness Coefficient	0.035
Channel Slope	0.007 ft/ft
Left Side Slope	4.000 H:V
Right Side Slope	4.000 H:V
Bottom Width	25.00 ft
Discharge	200.00 cfs
Results	
Normal Depth	18.9 in
Flow Area	49.2 ft ²
Wetted Perimeter	38.0 ft
Hydraulic Radius	15.5 in
Top Width	37.57 ft
Critical Depth	14.1 in
Critical Slope	0.018 ft/ft
Velocity	4.07 ft/s
Velocity Head	0.26 ft
Specific Energy	1.83 ft
Froude Number	0.627
Flow Type	Subcritical
GVF Input Data	
Downstream Depth	0.0 in
Length	0.0 ft
Number Of Steps	0
GVF Output Data	
Upstream Depth	0.0 in
Profile Description	N/A
Profile Headloss	0.00 ft
Downstream Velocity	0.00 ft/s
Upstream Velocity	0.00 ft/s
Normal Depth	18.9 in
Critical Depth	14.1 in
Channel Slope	0.007 ft/ft
Critical Slope	0.018 ft/ft

Relevant Criteria:
MHFD Urban Storm Drainage Criteria Manual, Volume 1, Table 12-3
for non-cohesive soils

Table 12-3. Hydraulic Design Criteria for Natural Unlined Channels

Design Parameter	Erosive Soils or Poor Vegetation	Erosion Resistant Soils and Vegetation
Maximum Low-flow Velocity (ft/sec)	3.5 ft/sec	5.0 ft/sec
Maximum 100-year Velocity (ft/sec)	5.0 ft/sec	7.0 ft/sec
Froude No., Low-flow	0.5	0.7
Froude No., 100-year	0.6	0.8
Maximum Tractive Force, 100-year	0.60 lb/sf	1.0 lb/sf

¹Velocities, Froude numbers and tractive force values listed are average values for the cross section.
²"Erosion resistant" soils are those with 30% or greater clay content. Soils with less than 30% clay content shall be considered "erosive soils."

CHANNEL WILL BE LINED
WITH TYPE L
VOID-PERMEATED RIPRAP

Tutt Blvd Outfall Channel

Project Description

Friction Method	Manning Formula
Solve For	Normal Depth

Input Data

Channel Slope	0.004 ft/ft
Discharge	36.00 cfs

Section Definitions

Station (ft)	Elevation (ft)
0+00.0	1.00
0+04.0	0.00
0+07.5	0.00
0+20.5	0.00
0+24.0	0.00
0+28.0	1.00

Roughness Segment Definitions

Start Station	Ending Station	Roughness Coefficient
(0+00.0, 1.00)	(0+07.5, 0.00)	0.070
(0+07.5, 0.00)	(0+20.5, 0.00)	0.035
(0+20.5, 0.00)	(0+28.0, 1.00)	0.070

Options

Current Roughness Weighted Method	Lotter's Method
Open Channel Weighting Method	Lotter's Method
Closed Channel Weighting Method	Pavlovskii's Method

Results

Normal Depth	10.2 in
Elevation Range	0.0 to 1.0 ft
Flow Area	20.0 ft ²
Wetted Perimeter	27.0 ft
Hydraulic Radius	8.9 in
Top Width	26.82 ft
Normal Depth	10.2 in
Critical Depth	5.4 in
Critical Slope	0.037 ft/ft
Velocity	1.80 ft/s
Velocity Head	0.05 ft
Specific Energy	0.90 ft
Froude Number	0.369
Flow Type	Subcritical

Relevant Criteria:
Colorado Springs Drainage Criteria Manual, Volume 1, Table 12-3 for non-cohesive soils

Table 12-3. Hydraulic Design Criteria for Natural Unlined Channels

Design Parameter	Erosive Soils or Poor Vegetation	Erosion Resistant Soils and Vegetation
Maximum Low-flow Velocity (ft/sec)	3.5 ft/sec	5.0 ft/sec
Maximum 100-year Velocity (ft/sec)	5.0 ft/sec	7.0 ft/sec
Froude No., Low-flow	0.5	0.7
Froude No., 100-year	0.6	0.8
Maximum Tractive Force, 100-year	0.60 lb/sf	1.0 lb/sf

¹ Velocities, Froude numbers and tractive force values listed are average values for the cross section.
² "Erosion resistant" soils are those with 30% or greater clay content. Soils with less than 30% clay content shall be considered "erosive soils."

GVF Input Data

Downstream Depth	0.0 in
Length	0.0 ft

Composite n Values.fm8
6/9/2023

Bentley Systems, Inc. Haestad Methods
Solution Center
27 Siemon Company Drive Suite 200 W
Watertown, CT 06795 USA +1-203-755-1666

FlowMaster
[10.02.00.01]
Page 1 of 2

Tutt Blvd Outfall Channel

GVF Input Data

Number Of Steps	0
-----------------	---

GVF Output Data

Upstream Depth	0.0 in
Profile Description	N/A
Profile Headloss	0.00 ft
Downstream Velocity	0.00 ft/s
Upstream Velocity	0.00 ft/s
Normal Depth	10.2 in
Critical Depth	5.4 in
Channel Slope	0.004 ft/ft
Critical Slope	0.037 ft/ft

Messages

Messages	Resulted weighted roughness is less than any individual roughness. Consider using Improved Lotters weighted roughness method.
----------	---

Springs Ranch Channel

Project Description

Friction Method	Manning Formula
Solve For	Normal Depth

Input Data

Channel Slope	0.025 ft/ft
Discharge	132.00 cfs

Section Definitions

Station (ft)	Elevation (ft)
-0+15	2.50
-0+09	0.00
0+09	0.00
0+15	2.50

Roughness Segment Definitions

Start Station	Ending Station	Roughness Coefficient
(-0+15, 2.50)	(-0+09, 0.00)	0.095
(-0+09, 0.00)	(0+09, 0.00)	0.057
(0+09, 0.00)	(0+15, 2.50)	0.095

Options

Current Roughness Weighted Method	Improved Lotter's Method
Open Channel Weighting Method	Improved Lotter's Method
Closed Channel Weighting Method	Pavlovskii's Method

See Springs Ranch Channel Grouted Boulder Sizing calculation sheet (in this appendix) for roughness coefficient calculations

Results

Normal Depth	18.4 in
Elevation Range	0.0 to 2.5 ft
Flow Area	33.2 ft ²
Wetted Perimeter	26.0 ft
Hydraulic Radius	15.4 in
Top Width	25.36 ft
Normal Depth	18.4 in
Critical Depth	13.5 in
Critical Slope	0.073 ft/ft
Velocity	3.97 ft/s
Velocity Head	0.24 ft
Specific Energy	1.78 ft
Froude Number	0.611
Flow Type	Subcritical

GVF Input Data

Downstream Depth	0.0 in
Length	0.0 ft

Springs Ranch Channel

GVF Input Data

Number Of Steps	0
-----------------	---

GVF Output Data

Upstream Depth	0.0 in
Profile Description	N/A
Profile Headloss	0.00 ft
Downstream Velocity	Infinity ft/s
Upstream Velocity	Infinity ft/s
Normal Depth	18.4 in
Critical Depth	13.5 in
Channel Slope	0.025 ft/ft
Critical Slope	0.073 ft/ft

Barnes Pond Outfall Channel

Project Description

Friction Method	Manning Formula
Solve For	Normal Depth

Input Data

Channel Slope	0.0043 ft/ft	2-YR RELEASE RATE FROM BARNES WATER QUALITY POND
Discharge	32.70 cfs	

Section Definitions

Station (ft)	Elevation (ft)
0+00.0	1.00
0+04.0	0.00
0+06.0	0.00
0+14.0	0.00
0+16.0	0.00
0+20.0	1.00

Roughness Segment Definitions

Start Station	Ending Station	Roughness Coefficient
(0+00.0, 1.00)	(0+06.0, 0.00)	0.070
(0+06.0, 0.00)	(0+14.0, 0.00)	0.030
(0+14.0, 0.00)	(0+20.0, 1.00)	0.070

Options

Current Roughness Weighted Method	Lotter's Method
Open Channel Weighting Method	Lotter's Method
Closed Channel Weighting Method	Pavlovskii's Method

Results

Normal Depth	11.7 in
Elevation Range	0.0 to 1.0 ft
Flow Area	15.4 ft ²
Wetted Perimeter	20.0 ft
Hydraulic Radius	9.3 in
Top Width	19.78 ft
Normal Depth	11.7 in
Critical Depth	6.9 in
Critical Slope	0.0279 ft/ft
Velocity	2.12 ft/s
Velocity Head	0.07 ft
Specific Energy	1.04 ft
Froude Number	0.422
Flow Type	Subcritical

Relevant Criteria:
Colorado Springs Drainage Criteria Manual, Volume 1, Table 12-3 for non-cohesive soils

Table 12-3. Hydraulic Design Criteria for Natural Unlined Channels

Design Parameter	Erosive Soils or Poor Vegetation	Erosion Resistant Soils and Vegetation
Maximum Low-flow Velocity (ft/sec)	3.5 ft/sec	5.0 ft/sec
Maximum 100-year Velocity (ft/sec)	5.0 ft/sec	7.0 ft/sec
Froude No., Low-flow	0.5	0.7
Froude No., 100-year	0.6	0.8
Maximum Tractive Force, 100-year	0.60 lb/sf	1.0 lb/sf

¹ Velocities, Froude numbers and tractive force values listed are average values for the cross section.
² "Erosion resistant" soils are those with 30% or greater clay content. Soils with less than 30% clay content shall be considered "erosive soils."

GVF Input Data

Downstream Depth	0.0 in
Length	0.0 ft

Barnes Pond Outfall Channel

GVF Input Data

Number Of Steps	0
-----------------	---

GVF Output Data

Upstream Depth	0.0 in
Profile Description	N/A
Profile Headloss	0.00 ft
Downstream Velocity	0.00 ft/s
Upstream Velocity	0.00 ft/s
Normal Depth	11.7 in
Critical Depth	6.9 in
Channel Slope	0.0043 ft/ft
Critical Slope	0.0279 ft/ft

Messages

Messages	Resulted weighted roughness is less than any individual roughness. Consider using Improved Lotters weighted roughness method.
----------	---

Wetland Swale

Project Description	
Friction Method	Manning Formula
Solve For	Discharge
Input Data	
Roughness Coefficient	0.060 ← Based on wetland vegetation in swale
Channel Slope	0.015 ft/ft
Normal Depth	2.0 in ← Depth of swale
Left Side Slope	100.000 H:V
Right Side Slope	5.000 H:V
Results	
Discharge	0.84 cfs ↗ At flows greater than 0.8 cfs, the wetland swale overtops and sheet flows to the pond bottom, then Sand Creek low-flow channel.
Flow Area	1.5 ft ²
Wetted Perimeter	17.5 ft
Hydraulic Radius	1.0 in
Top Width	17.50 ft
Critical Depth	1.3 in
Critical Slope	0.138 ft/ft
Velocity	0.58 ft/s
Velocity Head	0.01 ft
Specific Energy	0.17 ft
Froude Number	0.353
Flow Type	Subcritical
GVF Input Data	
Downstream Depth	0.0 in
Length	0.0 ft
Number Of Steps	0
GVF Output Data	
Upstream Depth	0.0 in
Profile Description	N/A
Profile Headloss	0.00 ft
Downstream Velocity	0.00 ft/s
Upstream Velocity	0.00 ft/s
Normal Depth	2.0 in
Critical Depth	1.3 in
Channel Slope	0.015 ft/ft
Critical Slope	0.138 ft/ft

Springs Ranch Low-Flow		
DA	0.24	mi ²
Q low-flow	58	cfs

$$Q_{low-flow} = 103 DA^{0.4}$$

(Eq. 6-2)

Where:

$Q_{low-flow}$ = design low-flow discharge (cfs)

DA = tributary drainage basin area (mi²)

Low Flow Springs Ranch Wetland Channel- Narrowest Reach

Project Description

Friction Method	Manning Formula
Solve For	Normal Depth

Input Data

Roughness Coefficient	0.060
Channel Slope	0.005 ft/ft
Left Side Slope	4.000 H:V
Right Side Slope	4.000 H:V
Bottom Width	35.00 ft
Discharge	58.00 cfs Springs Ranch Low-Flow

Results

Normal Depth	11.4 in
Flow Area	36.7 ft ²
Wetted Perimeter	42.8 ft
Hydraulic Radius	10.3 in
Top Width	42.57 ft
Critical Depth	5.2 in
Critical Slope	0.071 ft/ft
Velocity	1.58 ft/s
Velocity Head	0.04 ft
Specific Energy	0.98 ft
Froude Number	0.300
Flow Type	Subcritical

Relevant Criteria:
Colorado Springs Drainage Criteria Manual, Volume 1, Table 12-3 for non-cohesive soils

Table 12-3. Hydraulic Design Criteria for Natural Unlined Channels

Design Parameter	Erosive Soils or Poor Vegetation	Erosion Resistant Soils and Vegetation
Maximum Low-flow Velocity (ft/sec)	3.5 ft/sec	5.0 ft/sec
Maximum 100-year Velocity (ft/sec)	5.0 ft/sec	7.0 ft/sec
Froude No., Low-flow	0.5	0.7
Froude No., 100-year	0.6	0.8
Maximum Tractive Force, 100-year	0.60 lb/sf	1.0 lb/sf

¹ Velocities, Froude numbers and tractive force values listed are average values for the cross section.
² "Erosion resistant" soils are those with 30% or greater clay content. Soils with less than 30% clay content shall be considered "erosive soils."

GVF Input Data

Downstream Depth	0.0 in
Length	0.0 ft
Number Of Steps	0

GVF Output Data

Upstream Depth	0.0 in
Profile Description	N/A
Profile Headloss	0.00 ft
Downstream Velocity	0.00 ft/s
Upstream Velocity	0.00 ft/s
Normal Depth	11.4 in
Critical Depth	5.2 in
Channel Slope	0.005 ft/ft
Critical Slope	0.071 ft/ft

Low Flow Springs Ranch Wetland Channel- Widest Reach

Project Description

Friction Method	Manning Formula
Solve For	Normal Depth

Input Data

Roughness Coefficient	0.060
Channel Slope	0.005 ft/ft
Left Side Slope	4.000 H:V
Right Side Slope	4.000 H:V
Bottom Width	90.00 ft
Discharge	58.00 cfs Springs Ranch Low-Flow

Results

Normal Depth	6.6 in
Flow Area	50.4 ft ²
Wetted Perimeter	94.5 ft
Hydraulic Radius	6.4 in
Top Width	94.37 ft
Critical Depth	2.8 in
Critical Slope	0.086 ft/ft
Velocity	1.15 ft/s
Velocity Head	0.02 ft
Specific Energy	0.57 ft
Froude Number	0.278
Flow Type	Subcritical

Relevant Criteria:
Colorado Springs Drainage Criteria Manual, Volume 1, Table 12-3 for non-cohesive soils

Table 12-3. Hydraulic Design Criteria for Natural Unlined Channels

Design Parameter	Erosive Soils or Poor Vegetation	Erosion Resistant Soils and Vegetation
Maximum Low-flow Velocity (ft/sec)	3.5 ft/sec	5.0 ft/sec
Maximum 100-year Velocity (ft/sec)	5.0 ft/sec	7.0 ft/sec
Froude No., Low-flow	0.5	0.7
Froude No., 100-year	0.6	0.8
Maximum Tractive Force, 100-year	0.60 lb/sf	1.0 lb/sf

¹ Velocities, Froude numbers and tractive force values listed are average values for the cross section.
² "Erosion resistant" soils are those with 30% or greater clay content. Soils with less than 30% clay content shall be considered "erosive soils."

GVF Input Data

Downstream Depth	0.0 in
Length	0.0 ft
Number Of Steps	0

GVF Output Data

Upstream Depth	0.0 in
Profile Description	N/A
Profile Headloss	0.00 ft
Downstream Velocity	0.00 ft/s
Upstream Velocity	0.00 ft/s
Normal Depth	6.6 in
Critical Depth	2.8 in
Channel Slope	0.005 ft/ft
Critical Slope	0.086 ft/ft

MHFD/UDFCD Drainage Criteria Manual Volume 1 Chapter 8 Open Channels
Section 8.1.1 Mild slope Conditions - valid for subcritical flows and/or slopes less than 2%
Equation 8.11 was solved for velocity to calculate velocity thresholds.

A MINIMUM SIZE OF TYPE L WAS USED FOR ALL RIPRAP.

Sand Creek Main Channel Bank Lining

Variables:

- S 0.003 Longitudinal Channel Slope (ft/ft)
- Gs 2.5 Specific Gravity of stone (2.5 min, ranges from 2.5-2.7)

Riprap Type	D ₅₀	V (ft/s) - Threshold Mean Channel Velocity
VL	6	11.16
L	9	13.67
M	12	15.79
H	18	19.34
VH	24	22.33
		0.00

Sand Creek Channel Velocities = 2.7 fps

ONLY BANK PROTECTION PROVIDED

Sand Creek Riffle Lining

Variables:

- S 0.02 Longitudinal Channel Slope (ft/ft)
- Gs 2.5 Specific Gravity of stone (2.5 min, ranges from 2.5-2.7)

Riprap Type	D ₅₀	V (ft/s) - Threshold Mean Channel Velocity
VL	6	8.09
L	9	9.90
M	12	11.44
H	18	14.01
VH	24	16.17
		0.00

Sand Creek Riffle Velocities = 5.0 fps

Tutt Outfall Channel Lining

Variables:

- S 0.0048 Longitudinal Channel Slope (ft/ft)
- Gs 2.5 Specific Gravity of stone (2.5 min, ranges from 2.5-2.7)

Riprap Type	D ₅₀	V (ft/s) - Threshold Mean Channel Velocity
VL	6	10.31
L	9	12.62
M	12	14.58
H	18	17.85
VH	24	20.61

Tutt Outfall Channel Velocities = 1.8 fps

Downstream of Drop Structure

Variables:

- S 0.0065 Longitudinal Channel Slope (ft/ft)
- Gs 2.5 Specific Gravity of stone (2.5 min, ranges from 2.5-2.7)

Riprap Type	D ₅₀	Mean Channel Velocity
VL	6	9.79
L	9	11.99
M	12	13.84
H	18	16.95
VH	24	19.58

Sand Creek Channel Velocities = 4.1 fps

Barnes Pond Outfall Channel

Variables:

- S 0.0043 Longitudinal Channel Slope (ft/ft)
- Gs 2.5 Specific Gravity of stone (2.5 min, ranges from 2.5-2.7)

Riprap Type	D ₅₀	V (ft/s) - Threshold Mean Channel Velocity
VL	6	10.50
L	9	12.86
M	12	14.85
H	18	18.19
VH	24	21.00

Barnes Pond Outfall Channel Velocities= 2.1 fps

No riprap lining in Barnes Pond Outfall Channel

$$d_{50} \geq \left[\frac{VS^{0.17}}{4.5(G_s - 1)^{0.66}} \right]^2$$

Equation 8-11

Where:

V = mean channel velocity (ft/sec)

S = longitudinal channel slope (ft/ft)

d₅₀ = mean rock size (ft)

G_s = specific gravity of stone (minimum = 2.50, typically 2.5 to 2.7), Note: In this equation (G_s -1) considers the buoyancy of the water, in that the specific gravity of water is subtracted from the specific gravity of the rock.

Flat Portion of Barnes Pond Emergency Spillway

Variables:

- S 0.02 Longitudinal Channel Slope (ft/ft)
- Gs 2.5 Specific Gravity of stone (2.5 min, ranges from 2.5-2.7)

Riprap Type	D ₅₀	V (ft/s) - Threshold Mean Channel Velocity
VL	6	8.09
L	9	9.90
M	12	11.44
H	18	14.01
VH	24	16.17

Maximum Local Velocity on Flat portion of Emergency Spillway: 2.7 fps

HY-8 RESULTS FOR TAILWATER AND HEADWATER CONDITIONS NOT SUITABLE FOR MHFD-CULVERT SPREADSHEET

TUTT OUTFALL

OUTLET VELOCITY IS SUPERCRITICAL AND GREATER THAN ALLOWABLE FOR TYPE L RIPRAP IN TUTT OUTFALL CHANNLE ($V_{max} = 12.62$ FPS).

THE CALCULATIONS ON THE NEXT SHEETS SHOW THAT A HYDRAULIC JUMP OCCURS OVER THE TYPE H RIPRAP AT THE TUTT OUTFALL, UPSTREAM OF THE TRANSITION TO TYPE L TYPICAL CHANNEL LINING RIPRAP.

Discharge Names	Total Discharge	Culvert Discharge	headwater Elevation (ft)	Inlet Control Depth(ft)	Outlet Control Depth(ft)	Flow Type	Normal Depth (ft)	Critical Depth (ft)	Outlet Depth (ft)	Tailwater Depth (ft)	Outlet Velocity (ft/s)	Tailwater Velocity (ft/s)
2-YR	68.00	68.00	6517.58	1.88	-12.22	1-S2n	0.52	1.13	0.52	1.00	13.08	2.40
10-YR	103.00	103.00	6518.18	2.48	-8.69	1-JS1t	0.68	1.49	4.59	4.59	2.24	0.00
100-YR	191.00	191.00	6519.44	3.74	-5.80	1-JS1f	1.00	2.25	6.00	7.23	3.18	0.00

OUTLET VELOCITIES LESS THAN MAXIMUM ALLOWABLE VELOCITY FOR TYPE L RIPRAP IN TUTT OUTFALL CHANNEL ($V_{max} = 12.62$ FPS)

Culvert Summary Table - Culvert 1
— □ ×

Discharge Names	Total Discharge	Culvert Discharge	headwater Elevation (ft)	Inlet Control Depth(ft)	Outlet Control Depth(ft)	Flow Type	Normal Depth (ft)	Critical Depth (ft)	Outlet Depth (ft)	Tailwater Depth (ft)	Outlet Velocity (ft/s)	Tailwater Velocity (ft/s)
2-YR	68.00	68.00	6517.58	1.88	-12.22	1-S2n	0.52	1.13	0.52	1.00	13.08	2.40
10-YR	103.00	103.00	6518.18	2.48	-8.69	1-JS1t	0.68	1.49	4.59	4.59	2.24	0.00
100-YR	191.00	191.00	6519.44	3.74	-5.80	1-JS1f	1.00	2.25	6.00	7.23	3.18	0.00

Display

Crossing Summary Table

Culvert Summary Table Culvert 1

Water Surface Profiles

Tapered Inlet Table

Customized Table Options...

Geometry

Inlet Elevation: 6515.70 ft

Outlet Elevation: 6502.31 ft

Culvert Length: 450.20 ft

Culvert Slope: 0.0298

Culvert Rise: 6.00 ft

Culvert Span: 10.00 ft

Outlet Control: Full Flow

Plot

Crossing Rating Curve

Culvert Performance Curve

Selected Water Profile

Water Surface Profile Data

Help
Flow Types...
Edit Input Data...
Energy Dissipation...
AOP...
Low Flow...
Export Report
MS Word (*.docx)
Close

Project: SCP2
 Designer: TDM

Tutt Blvd Outfall Hydraulic Jump Analysis: 2-Year DBPS Flow

Will the jump start at XS510 (Toe of slope)?						
USDCM Eq. 9-4			USDCM Eq. 9-3			
y1 (Supercritical depth at XS 510) (ft)		0.53	Supercritical (XS 510)		Subcritical (XS 490)	
Fr1 (at XS 510)	1.24		Q (cfs)	68	Q (cfs)	68
			g (ft/s ²)	32.2	g (ft/s ²)	32.2
y2 (sequent depth) (ft)	0.70		A (ft ²)	13.27	A (ft ²)	28.55
Subcritical Depth at (XS 490) (ft)	1.01		z (ft)	0.27	z (ft)	0.505
			F supercritical(ft ³)	14.3	F subcritical(ft ³)	19.4
Is the subcritical depth greater than y2?	Yes		Is F sub greater than F super?			Yes

The subcritical depth at XS 490 (the downstream end of the existing soil cement) is greater than the sequent depth corresponding to XS 510 (the toe of the slope). Also, the specific force, F, of subcritical results at XS 490 is greater than the specific force of supercritical results at XS 510. This indicates a jump will start to form at or upstream of XS 510.

L/y2	4	From Fig 9-4
L (Length of Jump) (ft)	3	
River Station at Downstream End of Jump	507	

The 2-year event in Tutt Blvd Outfall and no ponding in SCP2 results in a hydraulic jump with its estimated downstream end at river station 507, which is over the existing soil cement. Tailwater caused by ponding in Pond 2 results in the hydraulic jump occurring within the Tutt Blvd Culvert, as shown in the HY-8 results.

$$F = \frac{Q^2}{gA} + \bar{z}A$$

Equation 9-3

Where:

F = specific force

Q = flow at cross section

g = acceleration of gravity

\bar{z} = distance from the water surface elevation to the centroid of the flow area (A)

A = area of flow

$$\frac{y_2}{y_1} = \frac{1}{2} \left(\sqrt{1 + 8F_1^2} - 1 \right)$$

Equation 9-4

Where:

y_2 = required depth of tailwater (also called the sequent depth, in feet)

y_1 = depth of water at drop toe, feet (taken from cross section at drop toe, supercritical HEC-RAS model)

F_1 = Froude Number = $V_1 / (gy_1)^{1/2}$ (based on depth and velocity at drop toe)

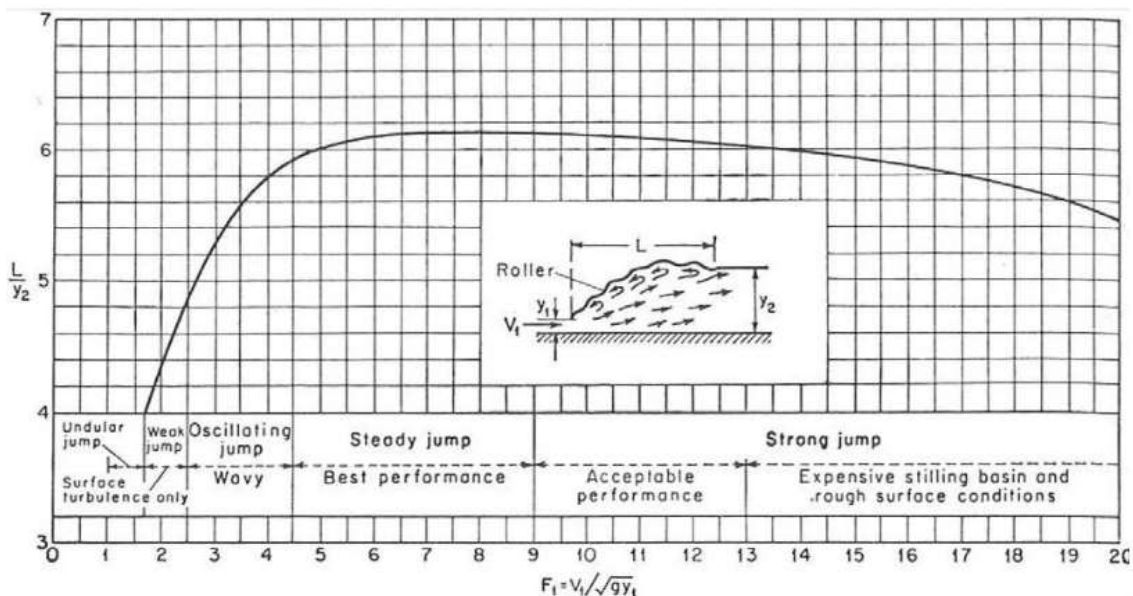

Hydraulic Jump at Tutt Outfall: HEC-RAS 1D Model

HEC-RAS River: Tutt Outfall Reach: Reach 1 Profile: PF 1

Reach	River Sta	Profile	Plan	Q Total (cfs)	Min Ch El (ft)	W.S. Elev (ft)	Crit W.S. (ft)	E.G. Elev (ft)	E.G. Slope (ft/ft)	Vel Chnl (ft/s)	Flow Area (sq ft)	Top Width (ft)	Froude # Chl	Hydr Depth C (ft)	Flow Area Ch (sq ft)
Reach 1	645	PF 1	Tutt_sub	68.00	6505.30	6506.43	6506.43	6506.99	0.002366	6.03	11.31	10.04	1.00	1.13	11.28
Reach 1	645	PF 1	Tutt_super	68.00	6505.30	6505.82	6506.43	6508.46	0.031004	13.04	5.22	10.02	3.18	0.52	5.21
Reach 1	545	PF 1	Tutt_sub	68.00	6502.30	6503.43	6503.43	6503.99	0.002366	6.03	11.30	10.03	1.00	1.13	11.28
Reach 1	545	PF 1	Tutt_super	68.00	6502.30	6502.83	6503.43	6505.42	0.029964	12.91	5.27	10.01	3.13	0.53	5.27
Reach 1	544	PF 1	Tutt_sub	68.00	6502.30	6503.20	6503.20	6503.59	0.028578	5.05	13.51	17.53	1.01	0.78	13.42
Reach 1	544	PF 1	Tutt_super	68.00	6502.30	6502.73	6503.20	6505.33	0.057959	12.95	5.26	17.38	4.15	0.30	5.24
Reach 1	522	PF 1	Tutt_sub	68.00	6501.92	6502.99	6502.50	6503.04	0.002898	1.83	37.23	39.64	0.33	0.94	37.21
Reach 1	522	PF 1	Tutt_super	68.00	6501.92	6502.40	6502.50	6502.77	0.076928	4.89	13.92	39.61	1.45	0.35	13.92
Reach 1	521	PF 1	Tutt_sub	68.00	6501.90	6502.89	6502.58	6503.03	0.008481	2.96	22.96	26.18	0.56	0.88	22.96
Reach 1	521	PF 1	Tutt_super	68.00	6501.90	6502.58	6502.58	6502.90	0.031091	4.52	15.06	24.24	1.01	0.62	15.06
Reach 1	510	PF 1	Tutt_sub	68.00	6501.70	6502.91	6502.38	6502.99	0.000831	2.23	33.03	55.31	0.38	1.07	30.13
Reach 1	510	PF 1	Tutt_super	68.00	6501.70	6502.29	6502.38	6502.70	0.011061	5.12	13.27	24.85	1.24	0.53	13.27
Reach 1	505.00*	PF 1	Tutt_sub	68.00	6501.70	6502.91	6502.38	6502.98	0.001329	2.24	32.65	54.44	0.38	1.06	29.94
Reach 1	505.00*	PF 1	Tutt_super	68.00	6501.70	6502.29	6502.38	6502.70	0.017381	5.13	13.25	24.84	1.24	0.53	13.25
Reach 1	500.00*	PF 1	Tutt_sub	68.00	6501.70	6502.90	6502.38	6502.98	0.002119	2.27	32.08	53.08	0.39	1.05	29.64
Reach 1	500.00*	PF 1	Tutt_super	68.00	6501.70	6502.27	6502.38	6502.71	0.029986	5.33	12.76	24.68	1.31	0.52	12.76
Reach 1	495.00*	PF 1	Tutt_sub	68.00	6501.70	6502.88	6502.38	6502.96	0.003021	2.31	31.24	51.04	0.40	1.03	29.18
Reach 1	495.00*	PF 1	Tutt_super	68.00	6501.70	6502.38	6502.38	6502.68	0.022774	4.42	15.38	25.54	1.00	0.60	15.38
Reach 1	490	PF 1	Tutt_sub	68.00	6501.70	6502.86	6502.38	6502.94	0.004447	2.37	30.12	48.19	0.41	1.01	28.55
Reach 1	490	PF 1	Tutt_super	68.00	6501.70	6502.38	6502.38	6502.68	0.030998	4.42	15.38	25.54	1.00	0.60	15.38
Reach 1	374	PF 1	Tutt_sub	68.00	6501.56	6502.73	6502.23	6502.81	0.004057	2.25	36.21	86.72	0.40	1.00	29.00
Reach 1	374	PF 1	Tutt_super	68.00	6501.56	6502.23	6502.23	6502.54	0.031702	4.46	15.25	25.43	1.02	0.60	15.25
Reach 1	267	PF 1	Tutt_sub	68.00	6501.03	6502.21	6501.72	6502.29	0.004308	2.29	34.12	73.72	0.41	0.99	28.71
Reach 1	267	PF 1	Tutt_super	68.00	6501.03	6501.72	6501.72	6502.03	0.031072	4.43	15.33	25.42	1.01	0.60	15.33

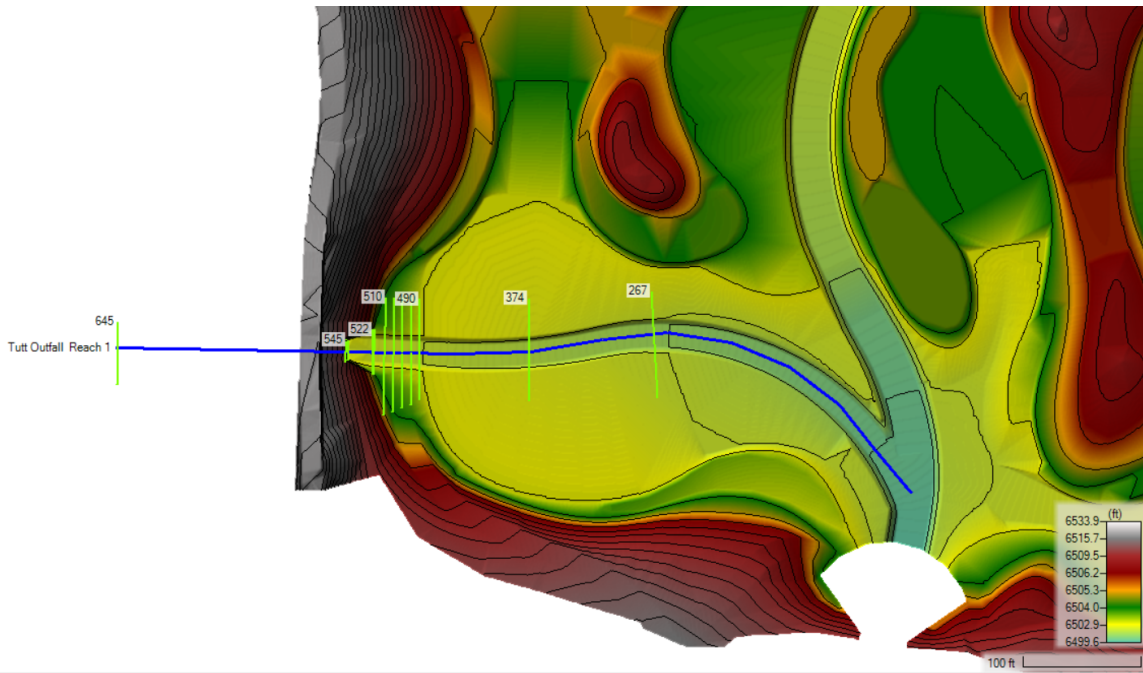

Figure 10: Full extents of the 1D HEC-RAS model used to evaluate the hydraulic jump that is expected to form at Tutt Outfall.

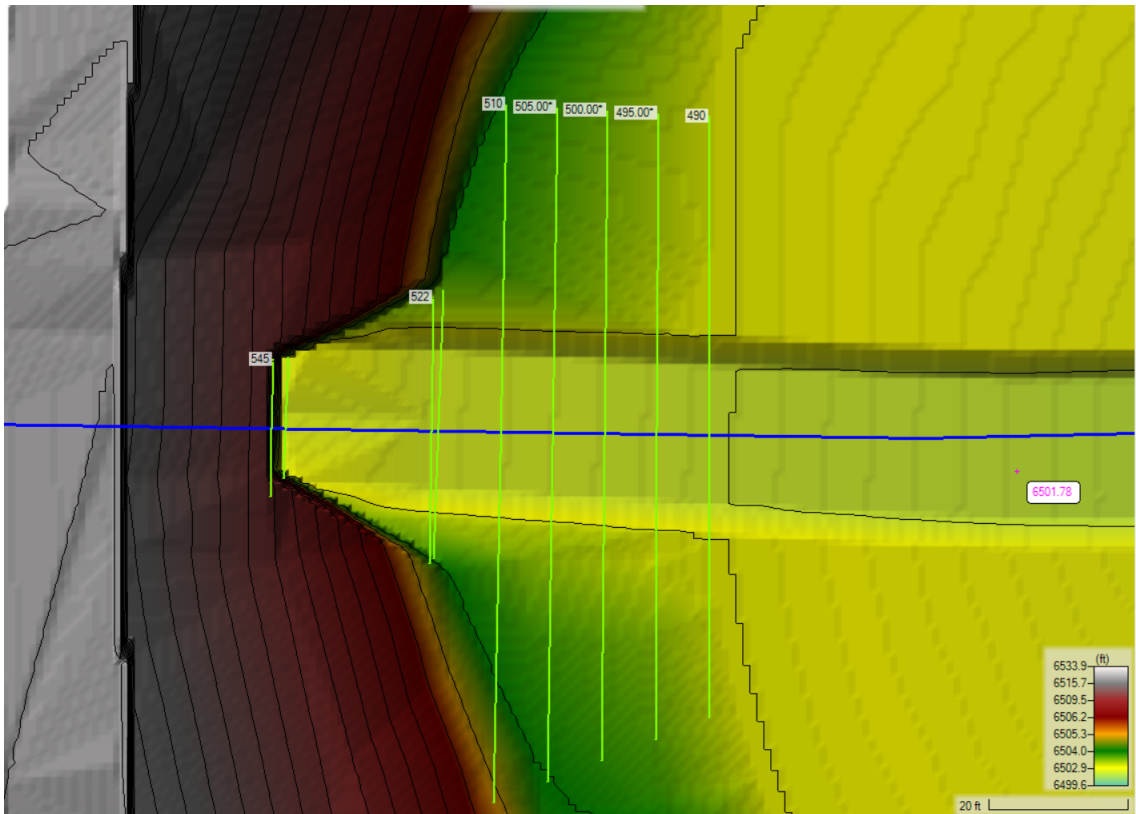
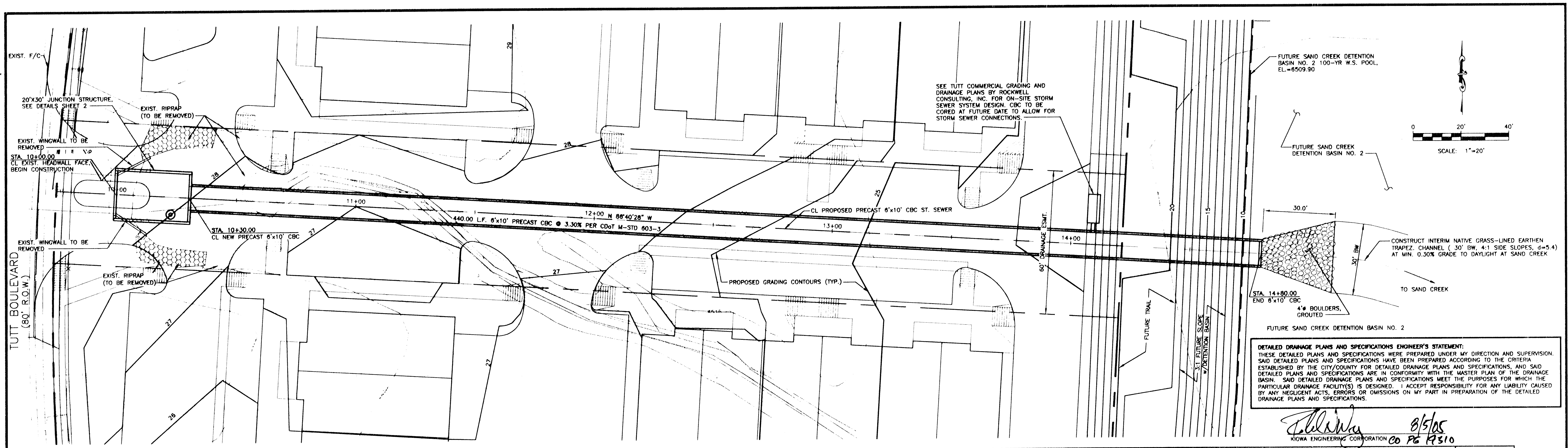

Figure 11: A zoomed-in image of Figure 10 at the location where the jump is estimated to occur.

0508-02-1
Tutt Blvd. Outfall



DETAILED DRAINAGE PLANS AND SPECIFICATIONS ENGINEER'S STATEMENT:
THESE DETAILED PLANS AND SPECIFICATIONS WERE PREPARED UNDER MY DIRECTION AND SUPERVISION. SAID DETAILED PLANS AND SPECIFICATIONS HAVE BEEN PREPARED ACCORDING TO THE CRITERIA ESTABLISHED BY THE CITY/COUNTY FOR DETAILED DRAINAGE PLANS AND SPECIFICATIONS, AND SAID DETAILED PLANS AND SPECIFICATIONS ARE IN CONFORMITY WITH THE MASTER PLAN OF THE DRAINAGE BASIN. SAID DETAILED DRAINAGE PLANS AND SPECIFICATIONS MEET THE PURPOSES FOR WHICH THE PARTICULAR DRAINAGE FACILITY(S) IS DESIGNED. I ACCEPT RESPONSIBILITY FOR ANY LIABILITY CAUSED BY ANY NEGLIGENT ACTS, ERRORS OR OMISSIONS ON MY PART IN PREPARATION OF THE DETAILED DRAINAGE PLANS AND SPECIFICATIONS.

John W. ... 8/5/05
KIOWA ENGINEERING CORPORATION CO. PG. 17310

0508-02
Features: Drainage Closed
Sheet 1 of 2

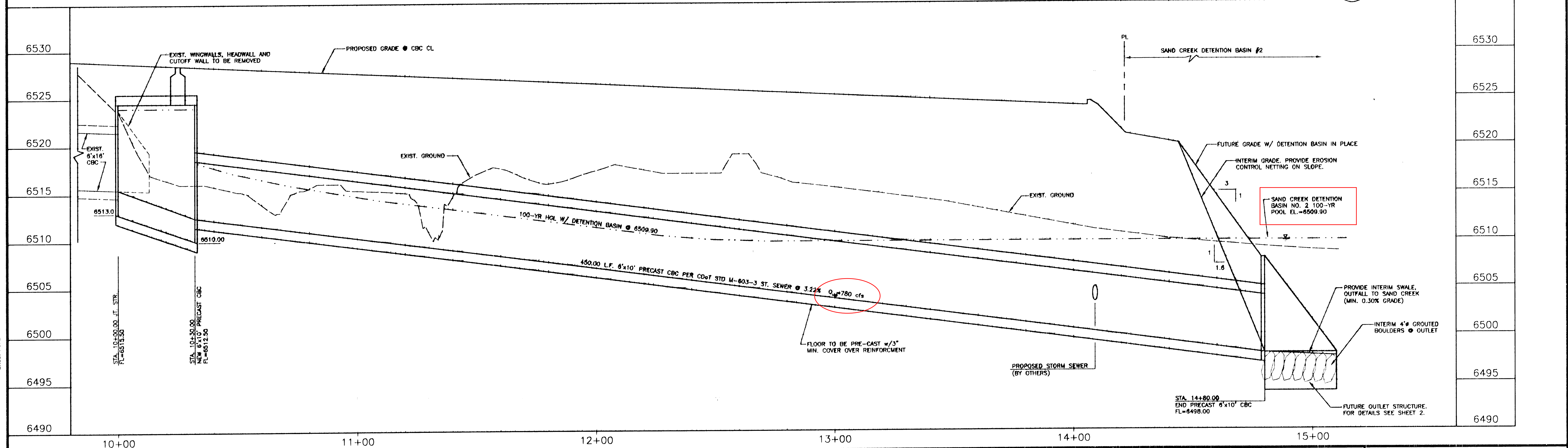

STATEMENT: THE CITY OF COLORADO SPRINGS RECOGNIZES THE DESIGN ENGINEER AS HAVING RESPONSIBILITY FOR THE DESIGN; THE CITY HAS LIMITED ITS SCOPE OF REVIEW ACCORDINGLY. RESUBMITTAL REQUIRED IF CONSTRUCTION HAS NOT COMMENCED WITHIN 180 DAYS AFTER REVIEW DATE.	REVIEW: TRAFFIC ENGINEERING _____ DATE _____ STREET DESIGN: _____ CURB GUTTER REVIEW _____ DATE _____ FINAL REVIEW _____ DATE _____	DESIGN DATA: SIDEWALKS: WIDTH <u>N/A</u> LOCATION: Attached <input type="checkbox"/> Detached <input type="checkbox"/> CURB TYPE 1 <input type="checkbox"/> 2 <input type="checkbox"/> 3 <input type="checkbox"/> R/W WIDTH <u>N/A</u> F/C - F/C <u>N/A</u> STREET TYPE <u>N/A</u> HVEEM _____	SCALE: HORIZ. 1"=20' VERT. 1"=5' BENCHMARK: Cp Post (punch on post), 4' to 5' high, 4" pipe on gas easement, approximately 150' east of Tutt Boulevard (N 13996.32061, E 7866.78878); Elevation = 6519.82.	REVISIONS: NO. DESCRIPTION DATE	ENGINEER: Kiowa Engineering Corporation 1604 South 21st Street Colorado Springs, Colorado 80904 (719) 630-7342 DESIGNED BY: <u>GCC</u> DATE: <u>8/5/05</u> DRAWN BY: <u>GCC</u> DATE: <u>8/5/05</u> CHECKED BY: <u>RNW</u> DATE: <u>8/5/05</u>	PROJECT <u>TUTT BOULEVARD OUTFALL</u> STORM SEWER PROFILE SUBDIVISION <u>TUTT COMMERCIAL CENTER</u> DRAINAGE BASIN <u>SAND CREEK</u> JOB NO. <u>05003</u> SHEET <u>1</u> OF <u>2</u>
	DRAINAGE DESIGN: FILED IN ACCORDANCE WITH SECTION 7-7-906 OF THE CODE OF COLORADO SPRINGS, SEPTEMBER 2001, AS AMENDED. <i>Clara M. ...</i> DATE <u>Aug 5, 2005</u>	ASPHALT THICKNESS: AC Surface _____ AC Base _____ AGG. BASE THICKNESS: Class 6 _____ Class 5 _____ Class 2 _____				

0508-02-1

DETERMINATION OF CULVERT HEADWATER AND OUTLET PROTECTION

MHFD-Culvert, Version 4.00 (May 2020)

Project: _____ **ID:** _____ BARNES POND OUTFALL LOW TAILWATER BASIN

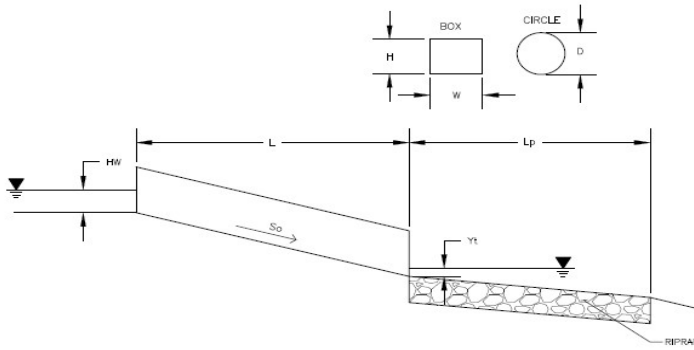

Soil Type:
Choose One:
 Sandy
 Non-Sandy

Design Information:	
Design Discharge	Q = <input type="text" value="197.4"/> cfs
Circular Culvert:	D = <input type="text" value="54"/> inches
Barrel Diameter in Inches	Square Edge with Headwall
Inlet Edge Type (Choose from pull-down list)	
OR:	OR
Box Culvert:	H (Rise) = <input type="text"/> ft
Barrel Height (Rise) in Feet	W (Span) = <input type="text"/> ft
Barrel Width (Span) in Feet	
Inlet Edge Type (Choose from pull-down list)	
Number of Barrels	# Barrels = <input type="text" value="1"/>
Inlet Elevation	Elev IN = <input type="text" value="6506"/> ft
Outlet Elevation OR Slope	Elev OUT = <input type="text" value="6505.53"/> ft
Culvert Length	L = <input type="text" value="94.46"/> ft
Manning's Roughness	n = <input type="text" value="0.013"/>
Bend Loss Coefficient	k _b = <input type="text" value="0"/>
Exit Loss Coefficient	k _x = <input type="text" value="1"/>
Tailwater Surface Elevation	Y _t Elevation = <input type="text" value="6509.54"/> ft
Max Allowable Channel Velocity	V = <input type="text" value="5"/> ft/s
Calculated Results:	
Culvert Cross Sectional Area Available	A = <input type="text" value="15.90"/> ft ²
Culvert Normal Depth	Y _n = <input type="text" value="4.50"/> ft
Culvert Critical Depth	Y _c = <input type="text" value="4.02"/> ft
Froude Number	Fr = <input type="text" value="-"/> Pressure flow!
Entrance Loss Coefficient	k _e = <input type="text" value="0.50"/>
Friction Loss Coefficient	k _f = <input type="text" value="0.40"/>
Sum of All Loss Coefficients	k _s = <input type="text" value="1.90"/> ft
Headwater:	
Inlet Control Headwater	HW _I = <input type="text" value="9.08"/> ft
Outlet Control Headwater	HW _O = <input type="text" value="8.32"/> ft
Design Headwater Elevation	HW = <input type="text" value="6515.12"/> ft
Headwater/Diameter OR Headwater/Rise Ratio	HW/D = <input type="text" value="2.03"/> HW/D > 1.5!
Outlet Protection:	
Flow/(Diameter ^{2.5})	Q/D ^{2.5} = <input type="text" value="4.61"/> ft ^{0.5} /s
Tailwater Surface Height	Y _t = <input type="text" value="4.01"/> ft
Tailwater/Diameter	Y _t /D = <input type="text" value="0.89"/>
Expansion Factor	1/(2*tan(θ)) = <input type="text" value="5.76"/>
Flow Area at Max Channel Velocity	A _t = <input type="text" value="39.58"/> ft ²
Width of Equivalent Conduit for Multiple Barrels	W _{eq} = <input type="text" value="-"/>
Length of Riprap Protection	L_p = <input type="text" value="31"/> ft
Width of Riprap Protection at Downstream End	T = <input type="text" value="10"/> ft
Adjusted Diameter for Supercritical Flow	D _a = <input type="text" value="-"/> ft
Minimum Theoretical Riprap Size	d ₅₀ min = <input type="text" value="7"/> in
Nominal Riprap Size	d ₅₀ nominal = <input type="text" value="9"/> in
MHFD Riprap Type	Type = <input type="text" value="L"/>

NOTE: DESIGN FLOW IS EQUAL TO THE FLOW THROUGH "OUTLET PLATE #1" WHEN THE POND WSE IS AT ITS MAXIMUM 100-YR PONDING DEPTH, AS CALCULATED IN THE MHFD DETENTION SPREADSHEET.

NOTE: TAILWATER EQUALS THE MAXIMUM PONDING DEPTH IN SAND CREEK POND 2 IN THE 25-YEAR STORM. SEE COINCIDENTAL OCCURRENCE TABLE 7-3 IN APPENDIX C

NOTED. THIS IS TO BE EXPECTED FOR A EDB OUTLET PIPE.

USDCM USES THE SAME METHOD TO SIZE RIPRAP FOR RIPRAP OUTLET APRONS AND LOW TAILWATER BASINS.

DETERMINATION OF CULVERT HEADWATER AND OUTLET PROTECTION

MHFD-Culvert, Version 4.00 (May 2020)

Project: _____ **ID:** _____ BARNES POND OUTFALL LOW TAILWATER BASIN

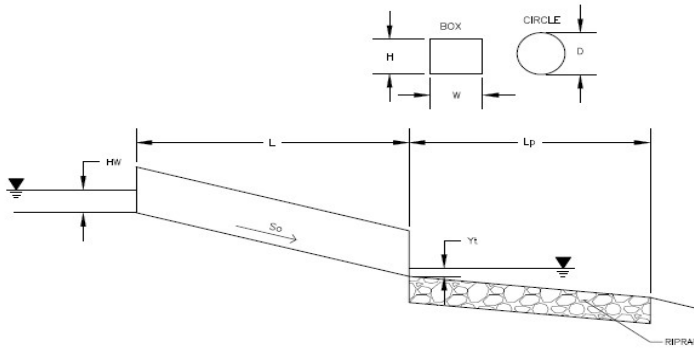

Soil Type:
Choose One:
 Sandy
 Non-Sandy

NOTED.

Supercritical Flow! Using Adjusted Diameter to calculate protection type.

Design Information:	
Design Discharge	Q = <input type="text" value="78.2"/> cfs
Circular Culvert:	D = <input type="text" value="54"/> inches
Barrel Diameter in Inches	Square Edge with Headwall
Inlet Edge Type (Choose from pull-down list)	OR
OR:	H (Rise) = <input type="text"/> ft
Box Culvert:	W (Span) = <input type="text"/> ft
Barrel Height (Rise) in Feet	# Barrels = <input type="text" value="1"/>
Barrel Width (Span) in Feet	Elev IN = <input type="text" value="6506"/> ft
Inlet Edge Type (Choose from pull-down list)	Elev OUT = <input type="text" value="6505.53"/> ft
Number of Barrels	L = <input type="text" value="94.46"/> ft
Inlet Elevation	n = <input type="text" value="0.013"/>
Outlet Elevation OR Slope	k _b = <input type="text" value="0"/>
Culvert Length	k _x = <input type="text" value="1"/>
Manning's Roughness	Y _t Elevation = <input type="text" value="6506.9"/> ft
Bend Loss Coefficient	V = <input type="text" value="5"/> ft/s
Exit Loss Coefficient	
Tailwater Surface Elevation	
Max Allowable Channel Velocity	

NOTE: DESIGN FLOW IS EQUAL TO THE FLOW THROUGH "OUTLET PLATE #1" WHEN THE POND WISE IS AT ITS MAXIMUM 10-YR PONDING DEPTH, AS CALCULATED IN THE MHFD DETENTION SPREADSHEET. THIS SMALLER DESIGN FLOW WAS USED WITH A LOWER TAIL WATER TO SEE IF IT PRODUCED A WORSE CONDITION THAN THE 100-YR OUTFLOW FROM THE WATER QUALITY POND.

Calculated Results:	
Culvert Cross Sectional Area Available	A = <input type="text" value="15.90"/> ft ²
Culvert Normal Depth	Y _n = <input type="text" value="2.41"/> ft
Culvert Critical Depth	Y _c = <input type="text" value="2.59"/> ft
Froude Number	Fr = <input type="text" value="1.14"/> Supercritical!
Entrance Loss Coefficient	k _e = <input type="text" value="0.50"/>
Friction Loss Coefficient	k _f = <input type="text" value="0.40"/>
Sum of All Loss Coefficients	k _s = <input type="text" value="1.90"/> ft
Headwater:	HW _I = <input type="text" value="3.90"/> ft
Inlet Control Headwater	HW _O = <input type="text" value="3.78"/> ft
Outlet Control Headwater	HW = 6509.90 ft
Design Headwater Elevation	HW/D = 0.87
Headwater/Diameter OR Headwater/Rise Ratio	
Outlet Protection:	Q/D ^{2.5} = <input type="text" value="1.82"/> ft ^{0.5} /s
Flow/(Diameter ^{2.5})	Y _t = <input type="text" value="1.37"/> ft
Tailwater Surface Height	Y _t /D = <input type="text" value="0.30"/>
Tailwater/Diameter	1/(2*tan(θ)) = <input type="text" value="4.42"/>
Expansion Factor	A _t = <input type="text" value="15.64"/> ft ²
Flow Area at Max Channel Velocity	W _{eq} = <input type="text" value="-"/> ft
Width of Equivalent Conduit for Multiple Barrels	L_p = 31 ft
Length of Riprap Protection	T = 12 ft
Width of Riprap Protection at Downstream End	Da = <input type="text" value="3.46"/> ft
Adjusted Diameter for Supercritical Flow	d ₅₀ min = <input type="text" value="10"/> in
Minimum Theoretical Riprap Size	d ₅₀ nominal = <input type="text" value="12"/> in
Nominal Riprap Size	Type = M
MHFD Riprap Type	

NOTE: TAILWATER EQUALS THE MAXIMUM PONDING DEPTH IN SAND CREEK POND 2 IN THE 5-YEAR STORM. SEE COINCIDENTAL OCCURRENCE TABLE 7-3 IN APPENDIX C

USDCM USES THE SAME METHOD TO SIZE RIPRAP FOR RIPRAP OUTLET APRONS AND LOW TAILWATER BASINS. THIS CONDITION REQUIRES A LARGER RIPRAP SIZE AND THEREFORE IS USED FOR DESIGN.

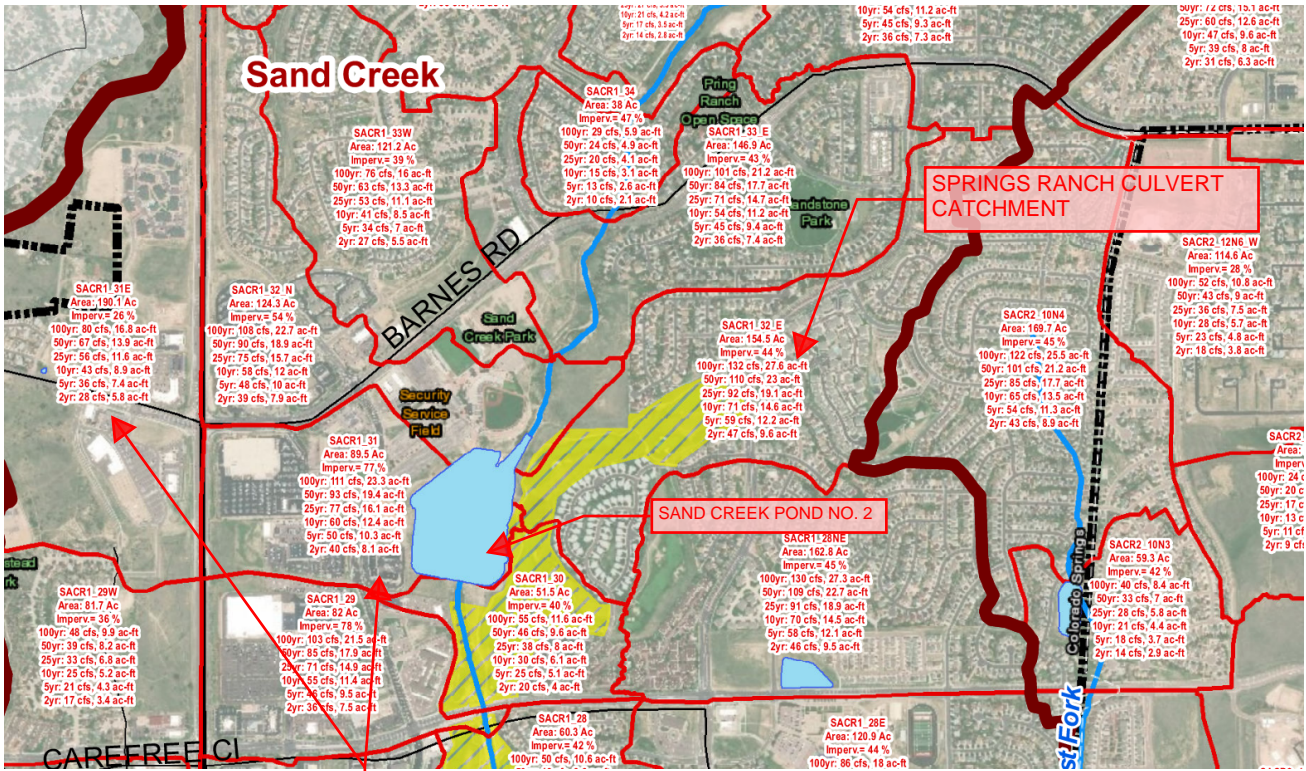

THIS FIGURE IS A ZOOMED IN AREA OF THE FLOWS SHOWN ON PAGE 128 OF THE SAND CREEK DRAINAGE BASIN PLANNING STUDY (2021)

table can be used to establish an appropriate design tailwater elevation for a storm drainage system based on the expected coincident storm frequency on the outfall channel. For example, if the receiving stream has a drainage area of 200 hectares and the storm drainage system has a drainage area of 2 hectares, the ratio of receiving area to storm drainage area is 200 to 2 which equals 100 to 1. From Table 7-3 and considering a 10-year design storm occurring over both areas, the flow rate in the main stream will be equal to that of a five year storm when the drainage system flow rate reaches its 10-year peak flow at the outfall. Conversely, when the flow rate in the main channel reaches its 10-year peak flow rate, the flow rate from the storm drainage system will have fallen to the 5-year peak flow rate discharge. This is because the drainage areas are different sizes, and the time to peak for each drainage area is different.

Area Ratio	Frequencies for Coincidental Occurrence			
	10-Year Design		100-Year Design	
	Main Stream	Tributary	Main Stream	Tributary
10,000 to 1	1	10	2	100
	10	1	100	2
1,000 to 1	2	10	10	100
	10	2	100	10
100 to 1	5	10	25	100
	10	5	100	25
10 to 1	10	10	50	100
	10	10	100	50
1 to 1	10	10	100	100
	10	10	100	100

There may be instances in which an excessive tailwater causes flow to back up the storm drainage system and out of inlets and access holes, creating unexpected and perhaps hazardous flooding conditions. The potential for this should be considered. Flap gates placed at the outlet can sometimes alleviate this condition; otherwise, it may be necessary to isolate the storm drain from the outfall by use of a pump station.

Energy dissipation may be required to protect the storm drain outlet. Protection is usually required at the outlet to prevent erosion of the outfall bed and banks. Riprap aprons or energy dissipators should be provided if high velocities are expected (see HEC-14, "Hydraulic Design of Energy Dissipators for Culverts and Channels"⁽³⁵⁾ for guidance with designing an appropriate dissipator).

The **orientation of the outfall** is another important design consideration. Where practical, the outlet of the storm drain should be positioned in the outfall channel so that it is pointed in a downstream direction. This will reduce turbulence and the potential for excessive erosion. If the outfall structure cannot be oriented in a downstream direction, the potential for outlet scour must be considered. For example, where a storm drain outfall discharges perpendicular to the direction of flow of the receiving channel, care must be taken to avoid erosion on the opposite channel bank. If erosion potential exists, a channel bank lining of riprap or other suitable material should be installed on the bank. Alternatively, an energy dissipator structure could be used at the storm drain outlet.

Springs Ranch Channel Grouted Boulder Sizing		
Estimated Boulder Size, D (ft)	3	
Estimated Depth of Flow, y (ft)	1.36	
y/D (minimum of 1)	1	
Manning's n for Boulders Grouted to 2/3 D	0.092	Equation 9-2
Composite Manning's n	0.070	From FlowMaster*
Velocity at toe, V (fps)	3.97	from FlowMaster
Slope, S (ft/ft)	0.025	
Specific Gravity of Rock, Ss	2.55	
Rock Sizing Parameter, Rp	1.59	Equation 9-7
Minimum Rock Size	B24	Table 9-4
Conclusion	Use B36 instead of B24 for aesthetics	

*Note: Composite n value was calculated using Improved Lotters's method. n= 0.095 on channel banks where boulders grouted to 2/3 D, n= 0.056 in channel bottom where boulders are grouted to 6" below top of boulder.

$$n_{24''-42''(2/3)} = \frac{0.086(y/D)^{0.16}}{\ln(2.55y/D)} \quad \text{Equation 9-2}$$

$$R_p = \frac{VS^{0.17}}{(S_s - 1)^{0.66}} \quad \text{Equation 9-7}$$

Table 9-4. Boulder sizes for various rock sizing parameters

Rock Sizing Parameter, R_p	Grouted Boulders ¹
	Boulder Classification ²
Less than 5.00	B24
5.00 to 5.59	B24
5.60 to 6.99	B36
7.00 to 8.00	B48

¹ Grouted to no less than 1/3 the height (+1"/- 0"), no more than 1/2 (+0"/- 1") of boulder height.

² See *Open Channels* chapter.

Barnes WQ Pond Outfall LTWB Grouted Boulder Sizing		
Estimated Boulder Size, D (ft)	3	
Estimated Depth of Flow, y (ft)	1.15	
y/D (minimum of 1)	1	
Manning's n for Boulders Grouted to 2/3 D	0.092	Equation 9-2
Critical Depth, y _c (LTWB approach) (ft)	1.167	from FlowMaster
Critical Velocity, V _c (LTWB approach) (fps)	6.1	PE Handbook Equation 6.4.3.2
Slope, S (ft/ft)	0.5	
Specific Gravity of Rock, S _s	2.55	
Rock Sizing Parameter, R _p	4.08	Equation 9-7
Minimum Rock Size	B24	Table 9-4
Conclusion	Use B36 instead of B24 for aesthetics	

$$n_{24}^{-42^{(2/3)}} = \frac{0.086(y/D)^{0.16}}{\ln(2.55y/D)}$$

Equation 9-2

Table 9-4. Boulder sizes for various rock sizing parameters

Rock Sizing Parameter, R _p	Grouted Boulders ¹
	Boulder Classification ²
Less than 5.00	B24
5.00 to 5.59	B24
5.60 to 6.99	B36
7.00 to 8.00	B48

¹ Grouted to no less than 1/3 the height (+1"/- 0"), no more than 1/2 (+0"/- 1") of boulder height.

² See *Open Channels* chapter.

Barnes WQ Pond Outfall Concrete Apron (Approach to LTWB) 100-Year Flow

Project Description	
Friction Method	Manning
	Formula
Solve For	Normal Depth
Input Data	
Roughness Coefficient	0.013
Channel Slope	0.003 ft/ft
Bottom Width	33.00 ft
Discharge	237.00 cfs
Results	
Normal Depth	13.4 in
Flow Area	36.8 ft ²
Wetted Perimeter	35.2 ft
Hydraulic Radius	12.5 in
Top Width	33.00 ft
Critical Depth	14.0 in
Critical Slope	0.003 ft/ft
Velocity	6.44 ft/s
Velocity Head	0.65 ft
Specific Energy	1.76 ft
Froude Number	1.076
Flow Type	Supercritical
GVF Input Data	
Downstream Depth	0.0 in
Length	0.0 ft
Number Of Steps	0
GVF Output Data	
Upstream Depth	0.0 in
Profile Description	N/A
Profile Headloss	0.00 ft
Downstream Velocity	Infinity ft/s
Upstream Velocity	Infinity ft/s
Normal Depth	13.4 in
Critical Depth	14.0 in
Channel Slope	0.003 ft/ft
Critical Slope	0.003 ft/ft

Hydraulic Analysis Report

Project Data

Project Title: Barnes Outfall Water Quality Pond

Designer: TDM

Project Date: Friday, July 21, 2023

Project Units: U.S. Customary Units

Notes: This weir calculation finds the WSE when the undetained 100-yr peak inflow goes over the emergency spillway.

Weir Analysis: Weir Analysis

Notes:

Input Parameters

Irregular Weir

Irregular Weir Geometry

Station (ft)	Elevation (ft)
0.00	6516.70
40.00	6515.00
240.00	6515.00
280.00	6516.70

Tailwater (above crest): 0.00 ft

Applied Coefficients

0	2.6424
1	2.73984
2	2.6424

Flow: 317.7000 cfs

Result Parameters

Head: 0.6714 ft

WSE= crest elev. + head = 6515.0 + 0.7ft = 6515.7

Project: Barnes Outfall Water Quality Pond & Sand Creek Pond No. 2
Designer: TDM

Barnes WQ Pond Emergency Spillway Protection No Tailwater	
COS DCM eq 13-9	
S (ft/ft)	0.07
Cf (Concentration factor)	3
Q (cfs)	349.3
Spillway Crest Length (ft)	75
q (cfs/ft)	4.66

Calculated D50 (in)	8.6
Riprap Type to be Used	Type L

Barnes WQ Pond Emergency Spillway Protection 2D Modeling Results (Sloped portion, with 100-year flow over Barnes WQ Pond Emergency Spillway and 25-year flow in SCP2)	
COS DCM eq 13-9	
S (ft/ft)	0.07
Cf (Concentration factor)	1
Velocity (fps)	3
Depth (ft)	3.4
q max (cfs/ft)	10.20

Calculated D50 (in)	7.2
Riprap Type to be Used	Type L

$$D_{50} = 5.23 S^{0.43} (1.35 C_f q)^{0.56}$$

Equation 13-9

Where:

- D_{50} = median rock size (in)
- S = longitudinal slope (ft/ft)
- C_f = concentration factor (1.0 to 3.0)
- q = unit discharge (cfs/ft)

When:

η (porosity) = 0.0 (i.e., for buried soil riprap)

Note: 2D model results were analyzed to find the highest unit discharge (q max) on the spillway. Because q max was used (instead of q average), the concentration factor (Cf) was set equal to 1.0

2D HEC-RAS Results: Barnes Pond 100-Year Flow (Undetained) Over Emergency Spillway with 25-Year Flow in Sand Creek Pond No. 2

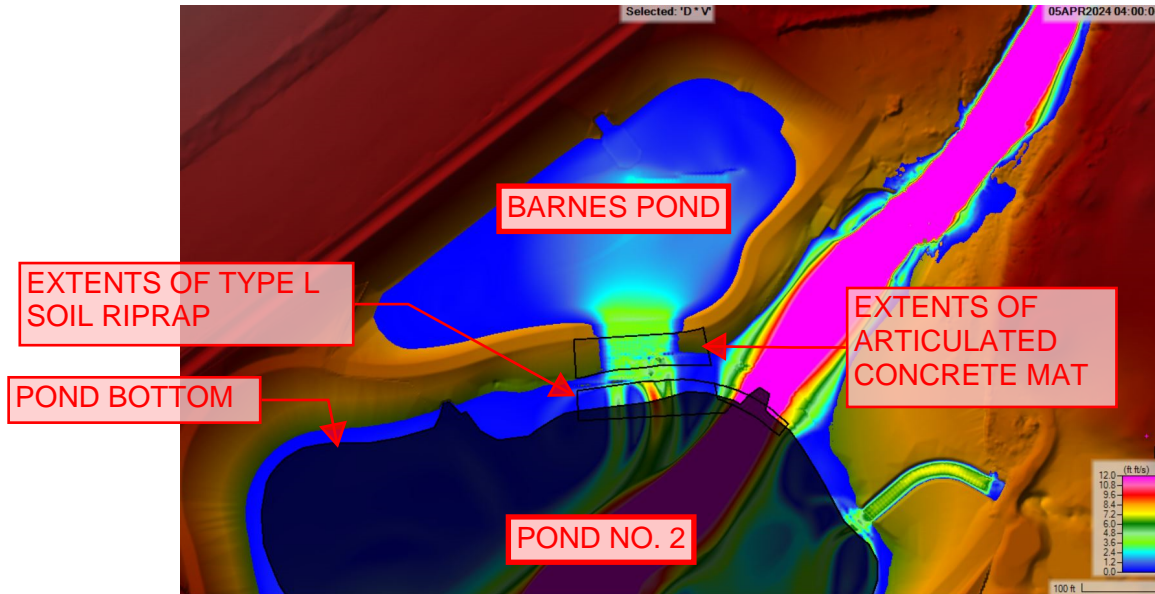

Figure 4: Unit discharge is shown as the product of depth and velocity. Model results in this image were used to evaluate the stability of the sloped portion of the type L soil riprap on the Barnes Pond emergency spillway. The bottom (flat) portion of Pond No. 2 is darkened because velocity, not unit discharge, was used to evaluate the flat portion of the spillway riprap. See Figures 6 and 7 for velocity results.

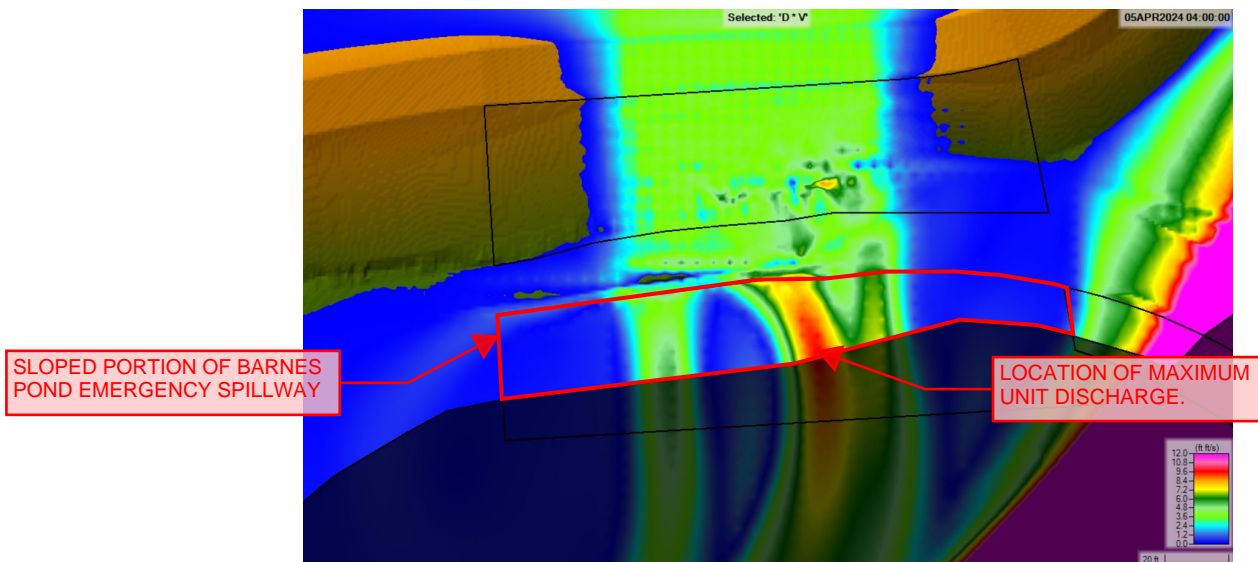

Figure 5: A zoomed-in image of the results shown in Figure 4. The maximum local unit discharge is 10.2 cfs/ft, which was used as an input in COS DCM Eq. 13-9.

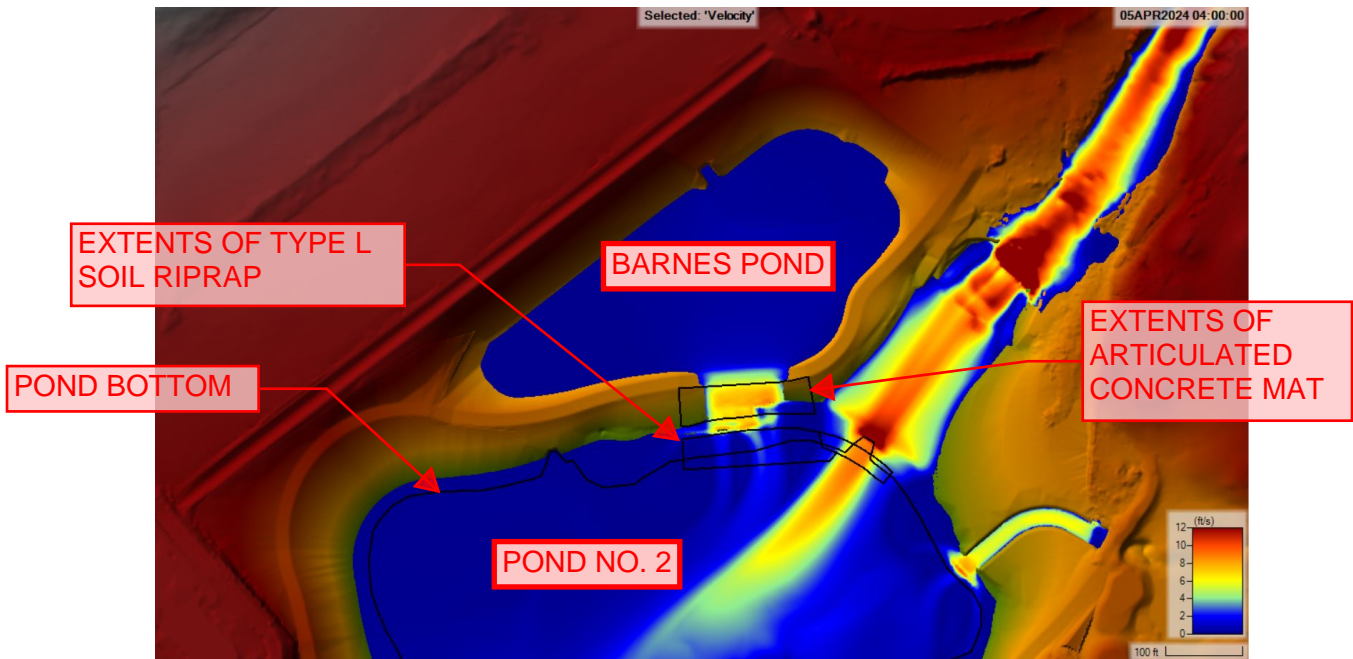

Figure 6: Velocity results are shown. Model results in this image were used to evaluate the stability of the flat portion of the type L soil riprap on the Barnes Pond emergency Spillway.

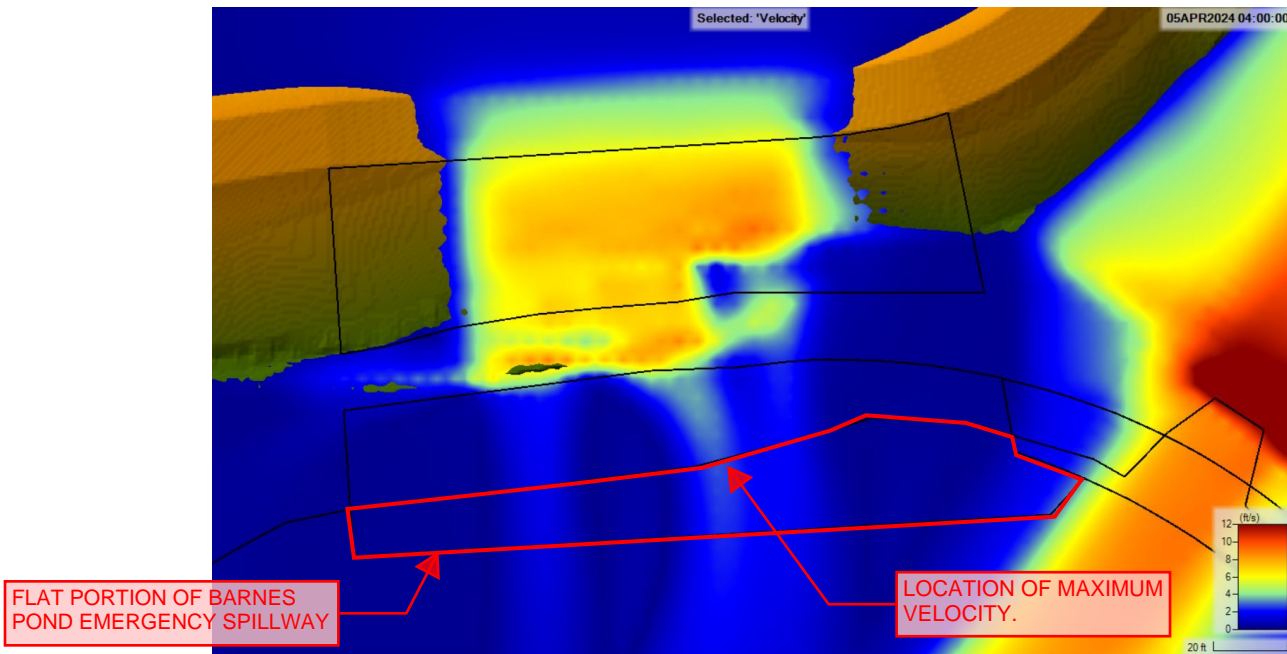

Figure 7: A zoomed-in image of the results shown in Figure 6. The maximum local velocity is 2.7 fps, which was used as an input in USDCM Eq. 8.11.

MHFD/UDFCD Drainage Criteria Manual Volume 2 Chapter 9 Hydraulic Structures
Section 2.4.3 Seepage Control - Lane's Weight Creep MethodExisting Soil Cement Drop Structure

Horizontal Creep Distance, L_H =	90 ft	*length of soil cement
Sheetpile depth =	2 ft	
Vertical Creep Distance, L_V =	4 ft	
Differential Head, H_s =	4 ft	*assume same as physical drop
Creep Ratio, C_w =	8.5	
Goal =	8.5	*silty sands found in Geotech borings

Top elevation of Soil Cement =	6512.4	*surveyed
Bedrock elevation =	6505.2	*Boring TH-2, 2006 construction drawings
Difference =	7.2	

Following Lane's Weighted Creep, a cutoff wall of only 2-feet is needed. However, visual evaluation completed by Vivid revealed undercutting upstream of the drop. Design proposes a cutoff wall from the drop structure to bedrock.

Table 9-3. Lane’s weighted creep: Recommended minimum ratios

Material	Ratio
Very fine sand or silt	8.5
Fine sand	7.0
Medium sand	6.0
Coarse sand	5.0
Fine gravel	4.0
Medium gravel	3.0
Coarse gravel including cobbles	3.0
Boulders with some cobbles and gravel	3.0
Soft clay	3.0
Medium clay	2.0
Hard clay	1.8
Very hard clay or hardpan	1.6

2. The weighted-creep head ratio is defined as:

$$C_w = \frac{\left(\frac{L_H}{3} + L_V \right)}{H_s}$$

Equation 9-5

Where:

C_w = creep ratio

H_s = differential head between analysis points (ft)

L_V = Vertical Creep Distance (ft)

L_H = Horizontal Creep Distance (ft)

HY-8 Culvert Analysis Report

Crossing Discharge Data

Discharge Selection Method: User Defined

Headwater Elevation (ft)	Discharge Names	Total Discharge (cfs)	Surveyed Discharge (cfs)	Roadway Discharge (cfs)	Iterations
6500.62	Design Low Flow	200.00	200.00	LOW FLOW IS ONLY CONVEYED THROUGH 2 CULVERTS. SEE REPORT FOR 2 CULVERT ANALYSIS	
6502.44	2-year	657.00	657.00	0.00	1
6503.45	5-year	970.00	970.00	0.00	1
6504.18	10-year	1221.00	1221.00	0.00	1
6504.90	25-year	1486.00	1486.00	0.00	1
6505.48	50-year	1715.00	1715.00	0.00	1
6506.06	DBPS 100-year OUT	1950.00	1950.00	0.00	1
6507.40	Design 100-year IN	2490.00	2490.00	0.00	1
6509.78	Orig Design 50-year	3360.00	3360.00	0.00	1
6513.72	FEMA 100-year	4500.00	4487.64	12.30	6
6516.41	Orig Design 100-year	7150.00	5107.16	2042.49	6
6513.30	Overtopping	4382.22	4382.22	0.00	Overtopping

Table 1 - Summary of Culvert Flows at Crossing: Existing Conditions

Rating Curve Plot for Crossing: Existing Conditions

Total Rating Curve

Crossing: Existing Conditions

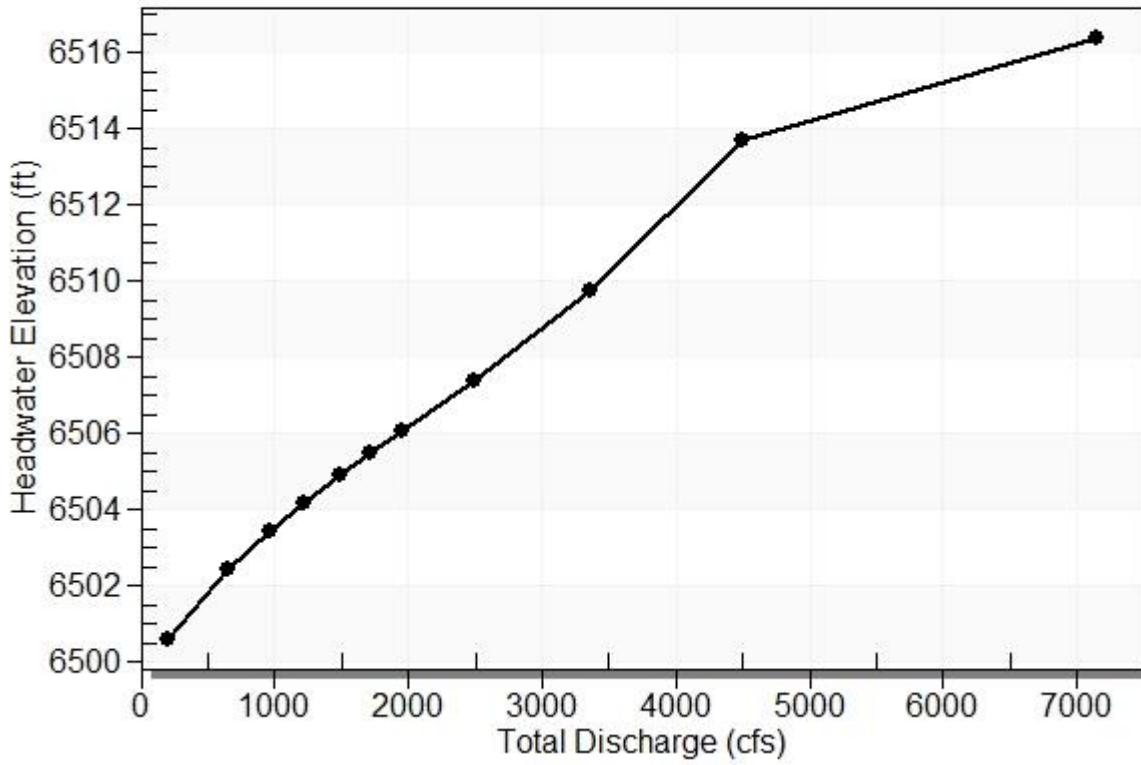

Table 2 - Culvert Summary Table: Surveyed

Discharge Names	Total Discharge (cfs)	Culvert Discharge (cfs)	Headwater Elevation (ft)	Inlet Control Depth (ft)	Outlet Control Depth (ft)	Flow Type	Normal Depth (ft)	Critical Depth (ft)	Outlet Depth (ft)	Tailwater Depth (ft)	Outlet Velocity (ft/s)	Tailwater Velocity (ft/s)
Design Low Flow	200.00	200.00	6500.62	1.509	0.587	1-S2n	0.842	0.986	0.869	1.274	6.393	2.952
2-year	657.00	657.00	6502.44	3.334	1.893	1-S2n	1.817	2.179	1.911	2.567	9.552	4.536
5-year	970.00	970.00	6503.45	4.336	2.686	1-S2n	2.360	2.825	2.501	3.220	10.774	5.189
10-year	1221.00	1221.00	6504.18	5.070	3.313	1-S2n	2.762	3.293	2.937	3.678	11.547	5.608
25-year	1486.00	1486.00	6504.90	5.786	3.980	1-S2n	3.165	3.754	3.373	4.117	12.239	5.986
50-year	1715.00	1715.00	6505.48	6.370	4.567	1-S2n	3.500	4.131	3.732	4.469	12.765	6.274
DBPS 100-year OUT	1950.00	1950.00	6506.06	6.953	5.184	1-S2n	3.833	4.500	4.089	4.807	13.247	6.540
Design 100-year IN	2490.00	2490.00	6507.40	8.287	6.671	5-S2n	4.572	5.296	4.867	5.519	14.211	7.072
Orig Design 50-year	3360.00	3360.00	6509.78	10.666	10.073	5-S2n	5.702	6.468	6.034	6.525	15.467	7.765
FEMA 100-year	4500.00	4487.64	6513.72	14.609	13.308	5-S2n	7.101	7.844	7.441	7.665	16.752	8.488
Orig Design 100-year	7150.00	5107.16	6516.41	17.297	16.243	4-FFf	8.000	8.000	8.000	9.846	17.733	9.732

Straight Culvert

Inlet Elevation (invert): 6499.11 ft, Outlet Elevation (invert): 6498.70 ft

Culvert Length: 90.00 ft, Culvert Slope: 0.0046

HEADWATER OF CULVERTS IS TAILWATER OF WEIR AND ORIFICE STRUCTURES

Site Data - Surveyed

Site Data Option: Culvert Invert Data

Inlet Station: 0.00 ft

Inlet Elevation: 6499.11 ft

Outlet Station: 90.00 ft

Outlet Elevation: 6498.70 ft

Number of Barrels: 3

Culvert Data Summary - Surveyed

Barrel Shape: Concrete Box

Barrel Span: 12.00 ft

Barrel Rise: 8.00 ft

Barrel Material: Concrete

Embedment: 0.00 in

Barrel Manning's n: 0.0130

Culvert Type: Straight

Inlet Configuration: Square Edge (30-75° flare) Wingwall

Inlet Depression: None

Tailwater Channel Data - Existing Conditions

Tailwater Channel Option: Trapezoidal Channel

Bottom Width: 50.00 ft

Side Slope (H:V): 2.50 (_:1)

Channel Slope: 0.0050

Channel Manning's n: 0.0400

Channel Invert Elevation: 6498.00 ft

Roadway Data for Crossing: Existing Conditions

Roadway Profile Shape: Irregular Roadway Shape (coordinates)

Irregular Roadway Cross-Section:

Coord No.	Station (ft)	Elevation (ft)
0	15.75	6521.90
1	201.50	6520.00
2	252.30	6516.00
3	289.00	6515.50
4	316.00	6517.90
5	340.00	6514.30
6	420.00	6513.90
7	488.00	6513.30
8	504.00	6517.00
9	529.00	6516.84
10	564.00	6515.55
11	622.00	6516.70
12	662.40	6521.15
13	863.18	6521.65
14	907.00	6523.30

Roadway Surface: Gravel

Roadway Top Width: 50.00 ft

HY-8 Culvert Analysis Report

Headwater Elevation (ft)	Discharge Names	Total Discharge (cfs)	Surveyed - Double - use for low flow only Discharge (cfs)	Roadway Discharge (cfs)	Iterations
6501.08	Design	200.00	200.00	0.00	1
6501.11	2-ft depth	205.00	205.00	0.00	1
6513.30	Overtopping	2023.07	2023.07	SEE REPORT FOR 3 CULVERT ANALYSIS FOR FLOWS GREATER THAN 200 CFS	

Table 1 - Summary of Culvert Flows at Crossing: Existing Conditions (Copy)

Rating Curve Plot for Crossing: Existing Conditions (Copy)

Total Rating Curve
Crossing: Existing Conditions (Copy)

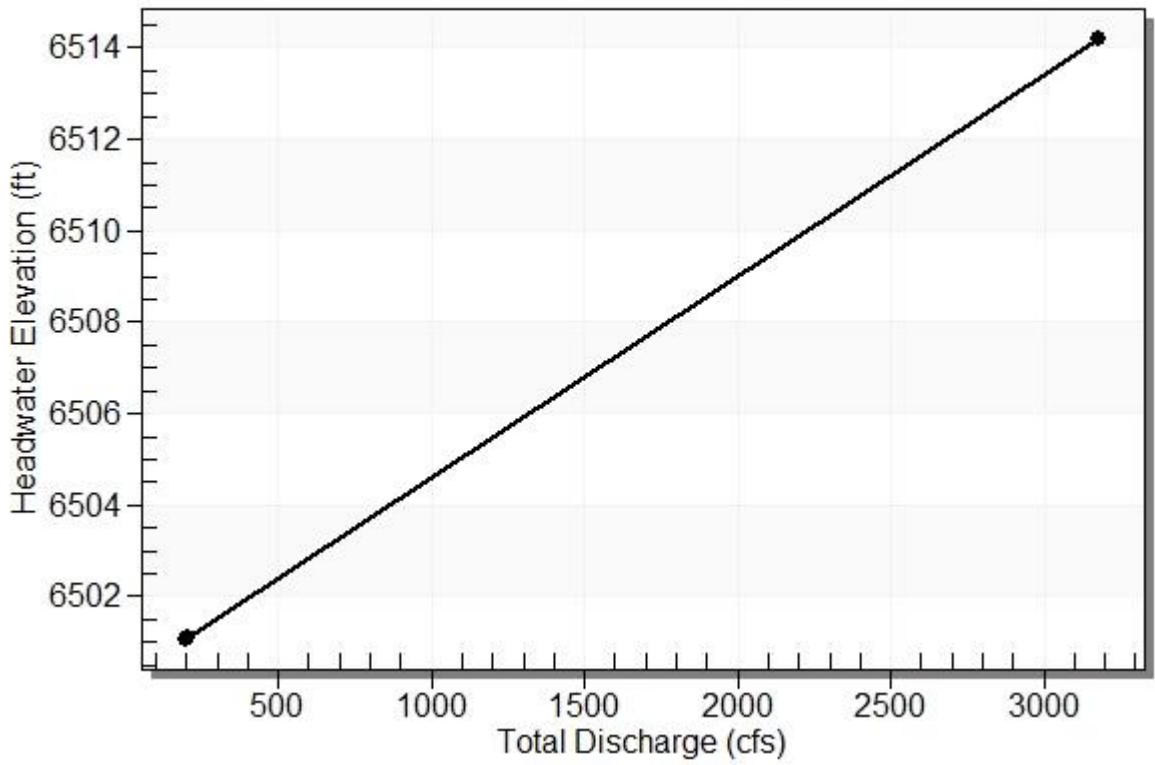

Table 2 - Culvert Summary Table: Surveyed - Double - use for low flow only

Discharge Names	Total Discharge (cfs)	Culvert Discharge (cfs)	Headwater Elevation (ft)	Inlet Control Depth (ft)	Outlet Control Depth (ft)	Flow Type	Normal Depth (ft)	Critical Depth (ft)	Outlet Depth (ft)	Tailwater Depth (ft)	Outlet Velocity (ft/s)	Tailwater Velocity (ft/s)
Design	200.00	200.00	6501.08	1.977	0.918	1-S2n	1.098	1.292	1.138	1.274	7.321	2.952
2-ft depth	205.00	205.00	6501.11	2.010	0.941	1-S2n	1.115	1.313	1.157	1.292	7.384	2.980

Straight Culvert

Inlet Elevation (invert): 6499.10 ft, Outlet Elevation (invert): 6498.70 ft

Culvert Length: 90.00 ft, Culvert Slope: 0.0044

Site Data - Surveyed - Double - use for low flow only

Site Data Option: Culvert Invert Data

Inlet Station: 0.00 ft

Inlet Elevation: 6499.10 ft

Outlet Station: 90.00 ft

Outlet Elevation: 6498.70 ft

Number of Barrels: 2

Culvert Data Summary - Surveyed - Double - use for low flow only

Barrel Shape: Concrete Box

Barrel Span: 12.00 ft

Barrel Rise: 8.00 ft

Barrel Material: Concrete

Embedment: 0.00 in

Barrel Manning's n: 0.0130

Culvert Type: Straight

Inlet Configuration: Square Edge (30-75° flare) Wingwall

Inlet Depression: None

Table 3 - Downstream Channel Rating Curve (Crossing: Existing Conditions (Copy))

Flow (cfs)	Water Surface Elev (ft)	Depth (ft)	Velocity (ft/s)	Shear (psf)	Froude Number
200.00	6499.27	1.27	2.95	0.40	0.47
205.00	6499.29	1.29	2.98	0.40	0.48

Tailwater Channel Data - Existing Conditions (Copy)

Tailwater Channel Option: Trapezoidal Channel

Bottom Width: 50.00 ft

Side Slope (H:V): 2.50 (_:1)

Channel Slope: 0.0050

Channel Manning's n: 0.0400

Channel Invert Elevation: 6498.00 ft

Roadway Data for Crossing: Existing Conditions (Copy)

Roadway Profile Shape: Irregular Roadway Shape (coordinates)

Irregular Roadway Cross-Section:

Coord No.	Station (ft)	Elevation (ft)
0	15.75	6521.90
1	201.50	6520.00
2	252.30	6516.00
3	289.00	6515.50
4	316.00	6517.90
5	340.00	6514.30
6	420.00	6513.90
7	488.00	6513.30
8	504.00	6517.00
9	529.00	6516.84
10	564.00	6515.55
11	622.00	6516.70
12	662.40	6521.15
13	863.18	6521.65
14	907.00	6523.30

Roadway Surface: Gravel

Roadway Top Width: 50.00 ft

Concrete Apron Channel

Project Description	
Friction Method	Manning Formula
Solve For	Normal Depth
Input Data	
Roughness Coefficient	0.013
Channel Slope	0.006 ft/ft
Bottom Width	25.00 ft
Discharge	200.00 cfs
Results	
Normal Depth	11.5 in
Flow Area	23.9 ft ²
Wetted Perimeter	26.9 ft
Hydraulic Radius	10.6 in
Top Width	25.00 ft
Critical Depth	15.1 in
Critical Slope	0.003 ft/ft
Velocity	8.38 ft/s
Velocity Head	1.09 ft
Specific Energy	2.05 ft
Froude Number	1.511
Flow Type	Supercritical
GVF Input Data	
Downstream Depth	0.0 in
Length	0.0 ft
Number Of Steps	0
GVF Output Data	
Upstream Depth	0.0 in
Profile Description	N/A
Profile Headloss	0.00 ft
Downstream Velocity	Infinity ft/s
Upstream Velocity	Infinity ft/s
Normal Depth	11.5 in
Critical Depth	15.1 in
Channel Slope	0.006 ft/ft
Critical Slope	0.003 ft/ft

Orifice

Project Description		
Solve For	Headwater Elevation	
Input Data		
Discharge	200.00 cfs	
Centroid Elevation	6,500.85 ft	
Tailwater Elevation	6,500.60 ft	
Discharge Coefficient	0.610	
Opening Width	25.00 ft	
Opening Height	2.5 ft	
Results		
Headwater Elevation	6,501.28 ft	DEPTH = 1.68 -> LESS THAN HEIGHT OF ORIFICE. THEREFORE, THE ORIFICE WILL ACT AS A WEIR AT LOW FLOW.
Headwater Height Above Centroid	0.43 ft	
Tailwater Height Above Centroid	-0.25 ft	
Flow Area	62.5 ft ²	
Velocity	3.20 ft/s	
Messages		
Notes	Centroid Elevation = $6499.6 + (2.5 / 2) = 6500.85$	

Orifice as Weir

Project Description	
Solve For	Headwater Elevation
Input Data	
Discharge	200.00 cfs
Crest Elevation	0.00 ft
Tailwater Elevation	0.00 ft
Weir Coefficient	3.10 ft ^(1/2) /s
Crest Length	25.0 ft
Number Of Contractions	0
Results	
Headwater Elevation	1.88 ft
Headwater Height Above Crest	1.88 ft
Tailwater Height Above Crest	0.00 ft
Flow Area	47.0 ft ²
Velocity	4.25 ft/s
Wetted Perimeter	28.8 ft
Top Width	25.00 ft

Hydraulic Analysis Report

Project Data

Project Title:

Designer:

Project Date: Tuesday, January 11, 2022

Project Units: U.S. Customary Units

Notes:

Weir Analysis: 3alt - Connect to Wingwalls - 250' Total Length

Notes: 10-feet removed from each corner for flow interference

Input Parameters

Irregular Weir

Coefficient: 3.1000

Irregular Weir Geometry

Station (ft)	Elevation (ft)
10.00	6513.00
26.00	6509.00
93.00	6509.00
97.00	6508.00
172.00	6508.00
176.00	6509.00
244.00	6509.00
260.00	6513.00

Tailwater (above crest): 0.00 ft

Applied Coefficients

0	3.095
1	3.095
2	3.095
3	3.095
4	3.095
5	3.095
6	3.095

Flow: 2500.0000 cfs

Result Parameters

Head: 2.9752 ft

100-YEAR WSE = 6511.0



MILE HIGH FLOOD DISTRICT DETENTION BASIN DESIGN WORKBOOK

*MHFD-Detention, Version 4.06 (July 2022)
Mile High Flood District
Denver, Colorado
www.mhfd.org*

Purpose: This workbook aids in the estimation of stormwater detention basin sizing and outlet routing based on the modified puls routing method for urban watersheds. Several different BMP types and various outlet configurations can be sized.

Function:

1. Approximates the stage-area-volume relationship for a detention basin based on watershed parameters and basin geometry parameters. Also evaluates existing user-defined basin stage-area relationships.
2. Sizes filtration media orifice, outlet orifices, elliptical slots, weirs, trash racks, and develops stage-discharge relationships. Uses the Modified Puls method to route a series of hydrographs (i.e., 2-, 5-, 10-, 25-, 50-, 100- and 500-year) and calibrates the peak discharge out of the basin to match the pre-development peak discharges for the watershed.

Content: This workbook consists of the following sheets:

Basin Tabulates stage-area-volume relationship estimates based on watershed parameters

Outlet Structure Tabulates a stage-discharge relationship for the user-defined outlet structure (inlet control).

Reference Provides reference equations and figures.

User Tips and Tools Provides instructions and video links to assist in using this workbook. Includes a stage-area calculator.

BMP Zone Images Provides images of typical BMP zone configurations corresponding with Zone pulldown selections.

Acknowledgements: *Spreadsheet Development Team:*
Ken MacKenzie, P.E., Holly Piza, P.E.
Mile High Flood District

Derek N. Rapp, P.E.
Peak Stormwater Engineering, LLC

Dr. James C.Y. Guo, Ph.D., P.E.
Professor, Department of Civil Engineering, University of Colorado at Denver

Comments? Direct all comments regarding this spreadsheet workbook to: [MHFD E-Mail](#)
Revisions? Check for revised versions of this or any other workbook at: [Downloads](#)

DETENTION BASIN STAGE-STORAGE TABLE BUILDER

MHFD- Detention, Version 4.06 (July 2022)

Project: Barnes Outfall Water Quality Pond

Basin ID:

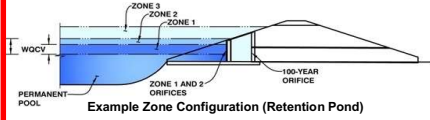

Example Zone Configuration (Retention Pond)

Information

Table with input parameters: Selected BMP Type = EDB, Watershed Area = 104.30 acres, Watershed Length = 6,135 ft, Watershed Length to Centroid = 2,250 ft, Watershed Slope = 0.042 ft/ft, Watershed Imperviousness = 78.90% percent, Percentage Hydrologic Soil Group A = 0.0% percent, Percentage Hydrologic Soil Group B = 100.0% percent, Percentage Hydrologic Soil Groups C/D = 0.0% percent, Target WQCV Drain Time = 40.0 hours, Location for 1-hr Rainfall Depths = User Input

Note: L / W Ratio > 8
L / W Ratio = 8.28

After providing required inputs above including 1-hour rainfall depths, click 'Run CUHP' to generate runoff hydrographs using the embedded Colorado Urban Hydrograph Procedure.

Table of runoff and detention volumes: Water Quality Capture Volume (WQCV) = 2.795 acre-feet, Excess Urban Runoff Volume (EURV) = 9.124 acre-feet, 2-yr Runoff Volume (P1 = 0.96 in.) = 6.378 acre-feet, 5-yr Runoff Volume (P1 = 1.24 in.) = 8.657 acre-feet, 10-yr Runoff Volume (P1 = 1.5 in.) = 10.912 acre-feet, 25-yr Runoff Volume (P1 = 1.89 in.) = 14.671 acre-feet, 50-yr Runoff Volume (P1 = 2.23 in.) = 17.798 acre-feet, 100-yr Runoff Volume (P1 = 2.6 in.) = 21.377 acre-feet, 500-yr Runoff Volume (P1 = 3.59 in.) = 30.661 acre-feet, Approximate 2-yr Detention Volume = 5.830 acre-feet, Approximate 5-yr Detention Volume = 7.873 acre-feet, Approximate 10-yr Detention Volume = 10.151 acre-feet, Approximate 25-yr Detention Volume = 11.996 acre-feet, Approximate 50-yr Detention Volume = 13.070 acre-feet, Approximate 100-yr Detention Volume = 14.361 acre-feet

Optional User Overrides table with columns for Volume (acre-feet) and Length (inches) for various stages.

Depth Increment = [input] ft

Main stage-storage table with columns: Stage - Storage Description, Stage (ft), Optional Override Stage (ft), Length (ft), Width (ft), Area (ft^2), Optional Override Area (ft^2), Area (acre), Volume (ft^3), Volume (ac-ft). Rows include Top of Micropool and stages 6508 through 6519.

Define Zones and Basin Geometry

Table of basin geometry parameters: Zone 1 Volume (WQCV) = 2.795 acre-feet, Zone 2 Volume (100-year - Zone 1) = 11.566 acre-feet, Select Zone 3 Storage Volume (Optional) = [input] acre-feet, Total Detention Basin Volume = 14.361 acre-feet, Initial Surcharge Volume (ISV) = user ft^3, Initial Surcharge Depth (ISD) = user ft, Total Available Detention Depth (Htotal) = user ft, Depth of Trickle Channel (Htc) = user ft, Slope of Trickle Channel (STC) = user ft/ft, Slopes of Main Basin Sides (Smain) = user H:V, Basin Length-to-Width Ratio (RLW) = user, Initial Surcharge Area (AISV) = user ft^2, Surcharge Volume Length (LISV) = user ft, Surcharge Volume Width (WISV) = user ft, Depth of Basin Floor (HFLOOR) = user ft, Length of Basin Floor (LFLOOR) = user ft, Width of Basin Floor (WFLOOR) = user ft, Area of Basin Floor (AFLOOR) = user ft^2, Volume of Basin Floor (VFLOOR) = user ft^3, Depth of Main Basin (HMAIN) = user ft, Length of Main Basin (LMAIN) = user ft, Width of Main Basin (WMAIN) = user ft, Area of Main Basin (AMAIN) = user ft^2, Volume of Main Basin (VMAIN) = user ft^3, Calculated Total Basin Volume (Vtotal) = user acre-feet

This sheet is an excerpt from Barnes Water Quality Pond Drainage Report

This sheet is an excerpt from Barnes Water Quality Pond Drainage Report

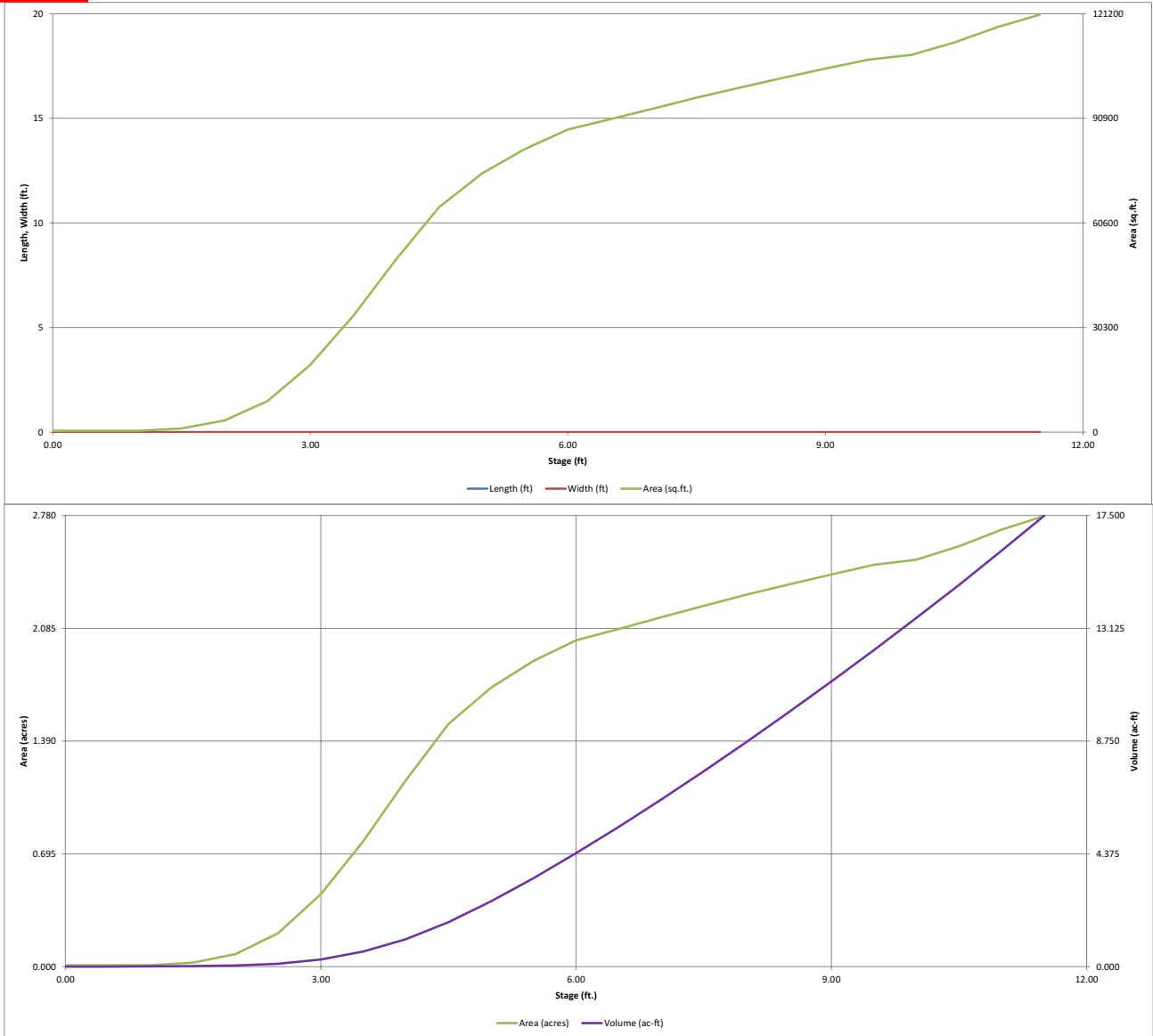

This sheet is an excerpt from Barnes Water Quality Pond Drainage Report

DETENTION BASIN OUTLET STRUCTURE DESIGN

MHFD-Detention, Version 4.06 (July 2022)

Project: Barnes Outfall Water Quality Pond

Basin ID:

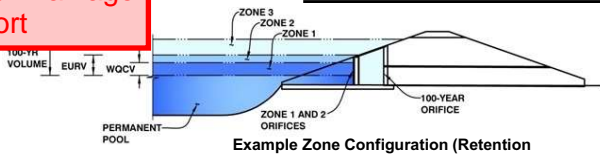

	Estimated Stage (ft)	Estimated Volume (ac-ft)	Outlet Type
(WQCV)	5.16	2.795	Orifice Plate
(100-year)	10.33	11.566	Weir&Pipe (Circular)
Zone 3			Not Utilized
Total (all zones)		14.361	

User Input: Orifice at Underdrain Outlet (typically used to drain WQCV in a Filtration BMP)

Underdrain Orifice Invert Depth =	N/A	ft (distance below the filtration media surface)	Underdrain Orifice Area =	N/A	ft ²
Underdrain Orifice Diameter =	N/A	inches	Underdrain Orifice Centroid =	N/A	feet

User Input: Orifice Plate with one or more orifices or Elliptical Slot Weir (typically used to drain WQCV and/or EURV in a sedimentation BMP)

Centroid of Lowest Orifice =	0.00	ft (relative to basin bottom at Stage = 0 ft)	WQ Orifice Area per Row =	4.688E-02	ft ²
Depth at top of Zone using Orifice Plate =	5.17	ft (relative to basin bottom at Stage = 0 ft)	Elliptical Half-Width =	N/A	feet
Orifice Plate: Orifice Vertical Spacing =	N/A	inches	Elliptical Slot Centroid =	N/A	feet
Orifice Plate: Orifice Area per Row =	6.75	sq. inches (use rectangular openings)	Elliptical Slot Area =	N/A	ft ²

User Input: Stage and Total Area of Each Orifice Row (numbered from lowest to highest)

	Row 1 (required)	Row 2 (optional)	Row 3 (optional)	Row 4 (optional)	Row 5 (optional)	Row 6 (optional)	Row 7 (optional)	Row 8 (optional)
Stage of Orifice Centroid (ft)	0.00	2.00	4.00					
Orifice Area (sq. inches)	6.75	6.75	6.75					

	Row 9 (optional)	Row 10 (optional)	Row 11 (optional)	Row 12 (optional)	Row 13 (optional)	Row 14 (optional)	Row 15 (optional)	Row 16 (optional)
Stage of Orifice Centroid (ft)								
Orifice Area (sq. inches)								

User Input: Vertical Orifice (Circular or Rectangular)

	Not Selected	Not Selected			Not Selected	Not Selected
Invert of Vertical Orifice =	N/A	N/A	ft (relative to basin bottom at Stage = 0 ft)	Vertical Orifice Area =	N/A	ft ²
Depth at top of Zone using Vertical Orifice =	N/A	N/A	ft (relative to basin bottom at Stage = 0 ft)	Vertical Orifice Centroid =	N/A	feet
Vertical Orifice Diameter =	N/A	N/A	inches			

User Input: Overflow Weir (Dropdown with Flat or Sloped Gate and Outlet Pipe OR Rectangular/Trapezoidal Weir and No Outlet Pipe)

	Zone 2 Weir	Not Selected			Zone 2 Weir	Not Selected
Overflow Weir Front Edge Height, H _o =	5.17	N/A	ft (relative to basin bottom at Stage = 0 ft)	Height of Gate Upper Edge, H _t =	5.17	N/A
Overflow Weir Front Edge Length =	12.00	N/A	feet	Overflow Weir Slope Length =	12.00	N/A
Overflow Weir Gate Slope =	0.00	N/A	H:V	Gate Open Area / 100-yr Orifice Area =	7.16	N/A
Horiz. Length of Weir Sides =	12.00	N/A	feet	Overflow Gate Open Area w/o Debris =	113.90	N/A
Overflow Gate Type =	Close Mesh Gate	N/A		Overflow Gate Open Area w/ Debris =	56.95	N/A
Debris Clogging % =	50%	N/A	%			

User Input: Outlet Pipe w/ Flow Restriction Plate (Circular Orifice, Restrictor Plate, or Rectangular Orifice)

	Zone 2 Circular	Not Selected			Zone 2 Circular	Not Selected
Depth to Invert of Outlet Pipe =	1.50	N/A	ft (distance below basin bottom at Stage = 0 ft)	Outlet Orifice Area =	15.90	N/A
Circular Orifice Diameter =	54.00	N/A	inches	Outlet Orifice Centroid =	2.25	N/A
				Half-Central Angle of Restrictor Plate on Pipe =	N/A	N/A

User Input: Emergency Spillway (Rectangular or Trapezoidal)

Spillway Invert Stage =	7.50	ft (relative to basin bottom at Stage = 0 ft)	Spillway Design Flow Depth =	1.07	feet
Spillway Crest Length =	75.00	feet	Stage at Top of Freeboard =	9.57	feet
Spillway End Slopes =	20.00	H:V	Basin Area at Top of Freeboard =	2.48	acres
Freeboard above Max Water Surface =	1.00	feet	Basin Volume at Top of Freeboard =	12.46	acre-ft

Routed Hydrograph Results

The user can override the default CUHP hydrographs and runoff volumes by entering new values in the Inflow Hydrographs table (Columns W through AF)

	WQCV	EURV	2 Year	5 Year	10 Year	25 Year	50 Year	100 Year	500 Year
Design Storm Return Period =									
One-Hour Rainfall Depth (in) =	N/A	N/A	0.96	1.24	1.50	1.89	2.23	2.60	3.59
CUHP Runoff Volume (acre-ft) =	2.795	9.124	6.378	8.657	10.912	14.671	17.798	21.377	30.661
Inflow Hydrograph Volume (acre-ft) =	N/A	N/A	6.378	8.657	10.912	14.671	17.798	21.377	30.661
CUHP Predevelopment Peak Q (cfs) =	N/A	N/A	0.9	8.0	20.3	56.4	78.7	108.4	175.8
TIONAL Override Predevelopment Peak Q (cfs) =	N/A	N/A							
Predevelopment Unit Peak Flow, q (cfs/acre) =	N/A	N/A	0.01	0.08	0.19	0.54	0.75	1.04	1.69
Peak Inflow Q (cfs) =	N/A	N/A	88.9	118.3	146.9	209.8	254.2	308.5	438.4
Peak Outflow Q (cfs) =	1.2	245.2	32.7	55.8	78.2	139.0	179.4	197.4	345.1
Ratio Peak Outflow to Predevelopment Q =	N/A	N/A	N/A	7.0	3.9	2.5	2.3	1.8	2.0
Structure Controlling Flow =	Plate	Spillway	Overflow Weir 1	Overflow Weir 1	Overflow Weir 1	Overflow Weir 1	Overflow Weir 1	Outlet Plate 1	Spillway
Max Velocity through Gate 1 (fps) =	N/A	1.82	0.28	0.5	0.7	1.2	1.6	1.7	1.8
Max Velocity through Gate 2 (fps) =	N/A	N/A	N/A	N/A	N/A	N/A	N/A	N/A	N/A
Time to Drain 97% of Inflow Volume (hours) =	38	38	40	39	38	36	34	32	28
Time to Drain 99% of Inflow Volume (hours) =	40	41	43	43	42	42	41	40	39
Maximum Ponding Depth (ft) =	5.16	8.19	5.71	5.95	6.15	6.61	6.88	7.40	8.16
Area at Maximum Ponding Depth (acres) =	1.77	2.32	1.94	2.00	2.03	2.10	2.13	2.21	2.31
Maximum Volume Stored (acre-ft) =	2.808	9.147	3.812	4.284	4.687	5.636	6.207	7.337	9.055

EURV NOT EVALUATED OR ACCURATELY REPRESENTED IN THIS TABLE. IF EURV IS NOT REQUIRED, SPREADSHEET DETERMINES DEPTH BASED ON ENTIRE EURV IN POND.

R24-129SI

Project:
Designer

SCP2
TDM

**Springs Ranch EX Soil Cement Hydraulic Jump Analysis
100-Year DBPS Flow from Springs Ranch**

Will the jump start at XS186 (Toe of Drop)?					
USDCM Eq. 9-4			USDCM Eq. 9-3		
y1 (Supercritical depth at XS 186) (ft)	0.26		Supercritical (XS 186)		Subcritical (XS 171)
Fr1 (at XS 186)	2.28		Q (cfs)	132	Q (cfs) 132
			g (ft/s ²)	32.2	g (ft/s ²) 32.2
y2 (sequent depth) (ft)	0.72		A (ft ²)	19.98	A (ft ²) 393.81
Subcritical Depth at (XS 171) (ft)	3.79		z (ft)	0.13	z (ft) 1.90
			F supercritical(ft ³)	29.7	F subcritical(ft ³) 747.6
Is the subcritical depth greater than y2?	Yes		Is F sub greater than F super?		Yes

The subcritical depth at XS 171 (the downstream end of the riprap apron) is greater than the sequent depth corresponding to XS186 (the toe of the drop). Also, the specific force, F, of subcritical results at XS 171 is greater than the specific force of supercritical results at XS 186. This indicates a jump will start to form at or upstream of XS 186.

L/y2	5.7	From Fig 9-4
L (Length of Jump) (ft)	4	
River Station at Downstream End of Jump	182	

The 100-year event in the Springs Ranch culverts and 25-year event in SCP2 results in a hydraulic jump with its estimated downstream end at river station 182. This flow/tailwater scenerio requires the longest length of the proposed riprap apron at the bottom of the Springs Ranch Channel. The proposed riprap apron extends 11ft past the downstream end of the hydraulic jump in this "worst-case" scenerio.

Project:
Designer

SCP2
TDM

**Springs Ranch EX Soil Cement Hydraulic Jump Analysis
10-Year DBPS Flow from Springs Ranch**

Will the jump start at XS186 (Toe of Drop)?					
USDCM Eq. 9-4		USDCM Eq. 9-3			
		Supercritical (XS 186)		Subcritical (XS 171)	
y1 (Supercritical depth at XS 186) (ft)	0.19	Q (cfs)	71	Q (cfs)	71
Fr1 (at XS 186)	2.00	g (ft/s ²)	32.2	g (ft/s ²)	32.2
y2 (sequent depth) (ft)	0.45	A (ft ²)	14.43	A (ft ²)	120.93
Subcritical Depth at (XS 171) (ft)	1.17	z (ft)	0.10	z (ft)	0.59
		F supercritical(ft ³)	12.2	F subcritical(ft ³)	72.0
Is the subcritical depth greater than y2?	Yes	Is F sub greater than F super?			Yes

The subcritical depth at XS 171 (the downstream end of the riprap apron) is greater than the sequent depth corresponding to XS 186 (the toe of the drop). Also, the specific force, F, of subcritical results at XS 171 is greater than the specific force of supercritical results at XS 186. This indicates a jump will start to form at or upstream of XS 186.

L/y2	4.4	From Fig 9-4
L (Length of Jump) (ft)	2	
River Station at Downstream End of Jump	184	

The 10-year event in the Springs Ranch culverts and 5-year event in SCP2 results in a hydraulic jump with its estimated downstream end at river station 184.

Project:
Designer:

SCP2
TDM

**Springs Ranch EX Soil Cement Hydraulic Jump Analysis
2-Year DBPS Flow from Springs Ranch**

Will the jump start at XS186 (Toe of Drop)?						
USDCM Eq. 9-4			USDCM Eq. 9-3			
y1 (Supercritical depth at XS 186) (ft)		0.15	Supercritical (XS 186)		Subcritical (XS 171)	
Fr1 (at XS 186)		1.88	Q (cfs)	47	Q (cfs)	47
			g (ft/s ²)	32.2	g (ft/s ²)	32.2
y2 (sequent depth) (ft)		0.33	A (ft ²)	11.44	A (ft ²)	40.8
Subcritical Depth at (XS 171) (ft)		0.39	z (ft)	0.08	z (ft)	0.195
			F supercritical(ft ³)	6.9	F subcritical(ft ³)	9.6
Is the subcritical depth greater than y2?	Yes		Is F sub greater than F super?			Yes

The subcritical depth at XS 171 (the downstream end of the riprap apron) is greater than the sequent depth corresponding to XS 186 (the toe of the drop). Also, the specific force, F, of subcritical results at XS 171 is greater than the specific force of supercritical results at XS 186. This indicates a jump will start to form at or upstream of XS 186.

L/y2	4.2	From Fig 9-4
L (Length of Jump) (ft)	1	
River Station at Downstream End of Jump	185	

The 2-year event in the Springs Ranch culverts and no ponding in SCP2 results in a hydraulic jump with its estimated downstream end at river station 185.

$$F = \frac{Q^2}{gA} + \bar{z}A \quad \text{Equation 9-3}$$

Where:

F = specific force

Q = flow at cross section

g = acceleration of gravity

\bar{z} = distance from the water surface elevation to the centroid of the flow area (A)

A = area of flow

$$\frac{y_2}{y_1} = \frac{1}{2} \left(\sqrt{1 + 8F_1^2} - 1 \right) \quad \text{Equation 9-4}$$

Where:

y_2 = required depth of tailwater (also called the sequent depth, in feet)

y_1 = depth of water at drop toe, feet (taken from cross section at drop toe, supercritical HEC-RAS model)

F_1 = Froude Number = $V_1/(gy_1)^{1/2}$ (based on depth and velocity at drop toe)

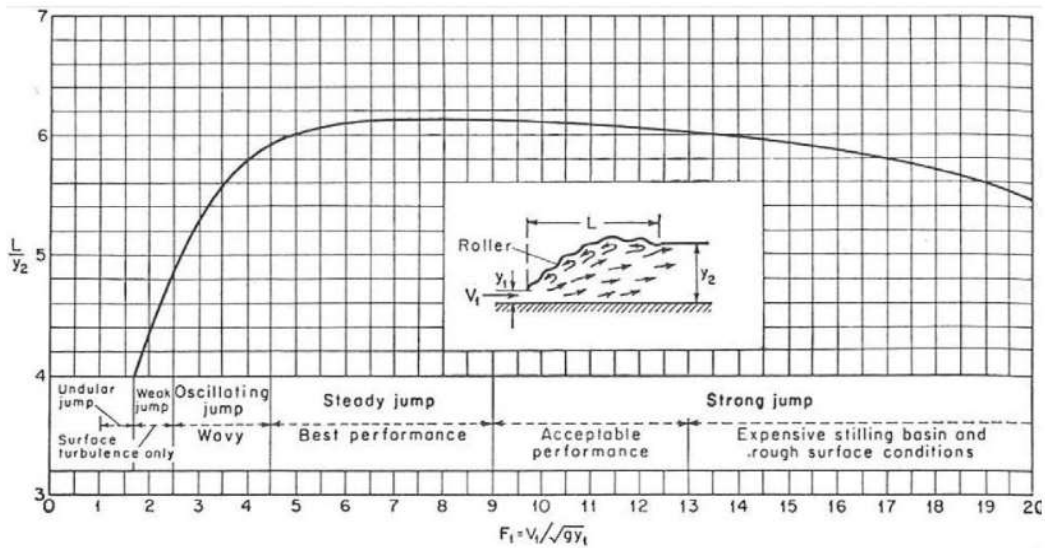

Hydraulic Jump at Springs Ranch Channel Existing Soil Cement: HEC-RAS 1D Model

HEC-RAS River: SR_RD Reach: 1 Profile: PF 1

Reach	River Sta	Profile	Plan	Q Total (cfs)	Min Ch El (ft)	W.S. Elev (ft)	Crit W.S. (ft)	E.G. Elev (ft)	E.G. Slope (ft/ft)	Vel Chnl (ft/s)	Flow Area (sq ft)	Top Width (ft)	Froude # Chl	Hydr Depth C (ft)	Flow Area Ch (sq ft)
1	375	PF 1	SR_RD_10yr_sub	71.00	6513.81	6514.98		6515.12	0.037113	2.99	23.75	23.59	0.53	1.01	23.75
1	375	PF 1	SR_RD_10yr_super	71.00	6513.81	6514.59	6514.59	6514.94	0.150943	4.71	15.06	21.75	1.00	0.69	15.06
1	375	PF 1	SR_RD_2yr_super	47.00	6513.81	6514.41	6514.41	6514.69	0.165973	4.18	11.23	20.91	1.01	0.54	11.23
1	375	PF 1	SR_RD_2yr_sub	47.00	6513.81	6514.70		6514.81	0.042370	2.70	17.38	22.23	0.54	0.78	17.38
1	375	PF 1	SR_RD_100yr_sub	132.00	6513.81	6515.54		6515.73	0.031464	3.48	37.94	26.34	0.51	1.44	37.94
1	375	PF 1	SR_RD_100yr_super	132.00	6513.81	6514.95	6514.95	6515.46	0.137749	5.69	23.20	23.48	1.01	0.99	23.20
1	283	PF 1	SR_RD_10yr_sub	71.00	6511.53	6513.07		6513.14	0.013746	2.15	33.02	25.44	0.33	1.30	33.02
1	283	PF 1	SR_RD_10yr_super	71.00	6511.53	6512.31	6512.31	6512.66	0.153938	4.74	14.98	21.80	1.01	0.69	14.98
1	283	PF 1	SR_RD_2yr_super	47.00	6511.53	6512.13	6512.13	6512.41	0.165314	4.18	11.24	20.87	1.01	0.54	11.24
1	283	PF 1	SR_RD_2yr_sub	47.00	6511.53	6512.77		6512.83	0.012891	1.83	25.64	23.99	0.31	1.07	25.64
1	283	PF 1	SR_RD_100yr_sub	132.00	6511.53	6513.65		6513.76	0.015284	2.72	48.46	28.18	0.37	1.72	48.46
1	283	PF 1	SR_RD_100yr_super	132.00	6511.53	6512.67	6512.67	6513.17	0.139806	5.71	23.11	23.53	1.02	0.98	23.11
1	228	PF 1	SR_RD_10yr_sub	71.00	6510.15	6510.92	6510.92	6511.27	0.153925	4.75	14.94	21.65	1.01	0.69	14.94
1	228	PF 1	SR_RD_10yr_super	71.00	6510.15	6510.92	6510.92	6511.27	0.153925	4.75	14.94	21.65	1.01	0.69	14.94
1	228	PF 1	SR_RD_2yr_super	47.00	6510.15	6510.75	6510.75	6511.02	0.165433	4.19	11.22	20.77	1.01	0.54	11.22
1	228	PF 1	SR_RD_2yr_sub	47.00	6510.15	6510.75	6510.75	6511.02	0.165433	4.19	11.22	20.77	1.01	0.54	11.22
1	228	PF 1	SR_RD_100yr_sub	132.00	6510.15	6511.29	6511.29	6511.79	0.136701	5.68	23.24	23.45	1.01	0.99	23.24
1	228	PF 1	SR_RD_100yr_super	132.00	6510.15	6511.29	6511.29	6511.79	0.138353	5.70	23.15	23.44	1.01	0.99	23.15
1	202	PF 1	SR_RD_10yr_sub	71.00	6509.38	6509.74	6509.74	6509.87	0.014787	1.86	32.55	110.40	0.61	0.28	29.01
1	202	PF 1	SR_RD_10yr_super	71.00	6509.38	6509.70	6509.74	6509.89	0.024054	2.13	27.91	110.40	0.76	0.24	24.73
1	202	PF 1	SR_RD_2yr_super	47.00	6509.38	6509.66	6509.69	6509.79	0.020017	1.69	22.73	110.40	0.67	0.20	19.96
1	202	PF 1	SR_RD_2yr_sub	47.00	6509.38	6509.69	6509.69	6509.78	0.012316	1.47	26.56	110.40	0.54	0.23	23.49
1	202	PF 1	SR_RD_100yr_sub	132.00	6509.38	6509.87	6509.87	6510.06	0.016153	2.48	46.62	110.40	0.68	0.41	41.98
1	202	PF 1	SR_RD_100yr_super	132.00	6509.38	6509.79	6509.88	6510.11	0.033572	3.07	37.13	110.40	0.95	0.33	33.23
1	193	PF 1	SR_RD_10yr_sub	71.00	6507.19	6507.82	6507.82	6508.00	0.036892	3.37	21.06	61.92	1.00	0.35	21.06
1	193	PF 1	SR_RD_10yr_super	71.00	6507.19	6507.57	6507.82	6508.08	0.894495	9.85	7.21	45.33	4.33	0.16	7.21
1	193	PF 1	SR_RD_2yr_super	47.00	6507.19	6507.51	6507.74	6508.06	1.162171	9.99	4.71	34.90	4.79	0.14	4.71
1	193	PF 1	SR_RD_2yr_sub	47.00	6507.19	6507.74	6507.74	6507.87	0.046223	2.94	15.97	61.98	1.00	0.27	15.97
1	193	PF 1	SR_RD_100yr_sub	132.00	6507.19	6509.53		6509.55	0.000369	1.07	123.02	62.16	0.13	2.06	123.02
1	193	PF 1	SR_RD_100yr_super	132.00	6507.19	6507.69	6508.00	6509.19	0.541119	9.80	13.48	59.35	3.58	0.23	13.48
1	186	PF 1	SR_RD_10yr_sub	71.00	6505.75	6506.92		6506.93	0.000434	0.81	88.17	129.57	0.13	1.15	87.93
1	186	PF 1	SR_RD_10yr_super	71.00	6505.75	6505.96	6506.07	6506.33	0.179257	4.91	14.46	115.69	2.00	0.19	14.43
1	186	PF 1	SR_RD_2yr_super	47.00	6505.75	6505.92	6506.00	6506.18	0.170822	4.11	11.45	112.43	1.88	0.15	11.44
1	186	PF 1	SR_RD_2yr_sub	47.00	6505.75	6506.20		6506.23	0.005087	1.43	32.89	117.40	0.39	0.43	32.81
1	186	PF 1	SR_RD_100yr_sub	132.00	6505.75	6509.54		6509.54	0.000023	0.37	372.28	150.81	0.04	3.38	325.37
1	186	PF 1	SR_RD_100yr_super	132.00	6505.75	6506.03	6506.22	6506.71	0.299446	6.60	20.03	116.15	2.28	0.26	19.98
1	179	PF 1	SR_RD_10yr_sub	71.00	6505.75	6506.92		6506.92	0.000284	0.66	108.36	138.50	0.11	1.16	107.84
1	179	PF 1	SR_RD_10yr_super	71.00	6505.75	6506.02	6506.02	6506.15	0.042022	2.90	24.50	120.36	1.00	0.26	24.36
1	179	PF 1	SR_RD_2yr_super	47.00	6505.75	6505.96	6505.96	6506.06	0.039063	2.44	19.29	119.52	0.95	0.21	19.18
1	179	PF 1	SR_RD_2yr_sub	47.00	6505.75	6506.17		6506.20	0.003749	1.21	38.98	122.20	0.33	0.42	38.78
1	179	PF 1	SR_RD_100yr_sub	132.00	6505.75	6509.54		6509.54	0.000017	0.33	417.43	149.81	0.03	3.48	384.12
1	179	PF 1	SR_RD_100yr_super	132.00	6505.75	6506.15	6506.15	6506.35	0.035272	3.58	36.97	121.95	1.00	0.39	36.78
1	171	PF 1	SR_RD_10yr_sub	71.00	6505.72	6506.92		6506.92	0.000223	0.59	121.69	144.20	0.10	1.17	120.93
1	171	PF 1	SR_RD_10yr_super	71.00	6505.72	6505.99	6505.99	6506.11	0.041430	2.80	25.36	125.64	1.00	0.24	25.19
1	171	PF 1	SR_RD_2yr_super	47.00	6505.72	6505.93	6505.93	6506.03	0.049634	2.51	18.73	122.84	1.04	0.18	18.61
1	171	PF 1	SR_RD_2yr_sub	47.00	6505.72	6506.14		6506.16	0.003646	1.15	41.06	129.81	0.32	0.39	40.80
1	171	PF 1	SR_RD_100yr_sub	132.00	6505.72	6509.54		6509.54	0.000014	0.32	434.40	154.88	0.03	3.79	393.81
1	171	PF 1	SR_RD_100yr_super	132.00	6505.72	6506.11	6506.11	6506.30	0.039111	3.53	37.44	129.01	1.04	0.36	37.20
1	163	PF 1	SR_RD_10yr_sub	71.00	6505.66	6506.91		6506.92	0.000290	0.57	126.06	152.81	0.09	1.20	125.04
1	163	PF 1	SR_RD_10yr_super	71.00	6505.66	6505.96	6505.96	6506.08	0.057660	2.78	25.63	137.02	0.98	0.24	25.44
1	163	PF 1	SR_RD_2yr_super	47.00	6505.66	6505.91	6505.91	6506.00	0.057534	2.36	19.98	134.78	0.95	0.19	19.83
1	163	PF 1	SR_RD_2yr_sub	47.00	6505.66	6506.12		6506.14	0.004865	1.12	42.08	140.75	0.31	0.40	41.73
1	163	PF 1	SR_RD_100yr_sub	132.00	6505.66	6509.54		6509.54	0.000020	0.32	420.00	161.92	0.03	3.78	403.98
1	163	PF 1	SR_RD_100yr_super	132.00	6505.66	6506.08	6506.08	6506.27	0.051466	3.44	38.50	140.30	1.00	0.37	38.21
1	144	PF 1	SR_RD_10yr_sub	71.00	6505.52	6506.91		6506.91	0.000304	0.59	121.66	123.33	0.09	1.23	117.68
1	144	PF 1	SR_RD_10yr_super	71.00	6505.52	6505.91	6505.91	6506.05	0.059026	2.97	23.87	91.10	1.02	0.26	23.87
1	144	PF 1	SR_RD_2yr_super	47.00	6505.52	6505.84	6505.84	6505.95	0.061594	2.58	18.23	88.24	1.00	0.21	18.23
1	144	PF 1	SR_RD_2yr_sub	47.00	6505.52	6505.88		6505.96	0.036729	2.19	21.45	89.90	0.79	0.24	21.45
1	144	PF 1	SR_RD_100yr_sub	132.00	6505.52	6509.54		6509.54	0.000018	0.31	453.06	154.89	0.03	3.86	369.64
1	144	PF 1	SR_RD_100yr_super	132.00	6505.52	6506.05	6506.05	6506.25	0.050460	3.62	36.46	95.81	1.01	0.40	36.46
1	132	PF 1	SR_RD_10yr_sub	71.00	6505.20	6506.91		6506.91	0.000132	0.43	168.11	130.88	0.06	1.43	159.66
1	132	PF 1	SR_RD_10yr_super	71.00	6505.20	6505.62	6505.62	6505.76	0.055955	3.02	23.51	83.51	1.00	0.28	23.51
1	132	PF 1	SR_RD_2yr_super	47.00	6505.20	6505.54	6505.54	6505.65	0.059858	2.68	17.53	78.24	1.00	0.22	17.53
1	132	PF 1	SR_RD_2yr_sub	47.00	6505.20	6505.72		6505.75	0.009338	1.46	32.24	89.09	0.43	0.36	32.24
1	132	PF 1	SR_RD_100yr_sub	132.00	6505.20	6509.54		6509.54	0.000011	0.25	584.68	176.62	0.02	4.06	453.33
1	132	PF 1	SR_RD_100yr_super	132.00	6505.20	6505.77	6505.77	6505.97	0.048765	3.55	37.16	93.30	0.99	0.40	37.16
1	81	PF 1	SR_RD_10yr_sub	71.00	6504.97	6506.90		6506.91	0.000087	0.35	208.82	132.16	0.05	1.70	203.77
1	81	PF 1	SR_RD_10yr_super	71.00	6504.97	6505.25	6505.25	6505.38	0.056547	2.88	24.67	94.93	1.00	0.26	24.67
1	81	PF 1	SR_RD_2yr_super	47.00	6504.97	6505.18	6505.18	6505.28	0.059829	2.49	18.86	93.97	0.98	0.20	18.86
1	81	PF 1	SR_RD_2yr_sub	47.00	6504.97	6505.46		6505.47	0.003475	1.04	45.10	98.23	0.27	0.46	45.10
1	81	PF 1	SR_RD_100yr_sub	132.00	6504.97	6509.54		6509.54	0.000008	0.23	611.40	163.35	0.02	4.31	523.77
1	81	PF 1	SR_RD_100yr_super	132.00	6504.97	6505.38	6505.38	6505.57	0.051047	3.55	37.23	96.99	1.01	0.38	37.23
1	12	PF 1	SR_RD_10yr_sub	71.00	6504.66	6506.90		6506.90	0.000048	0.34	220.11	127.90	0.04	2.07</	

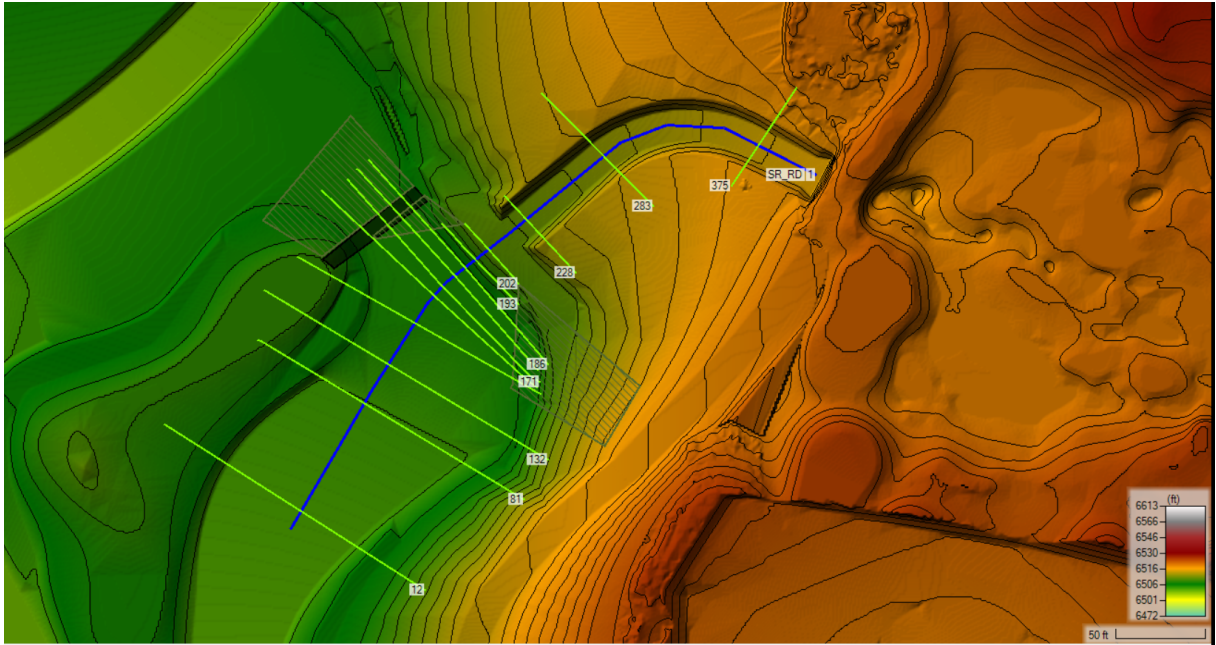

Figure 8: Full extents of the 1D HEC-RAS model used to evaluate the hydraulic jump that is expected to form at the downstream end of the Springs Ranch Channel.

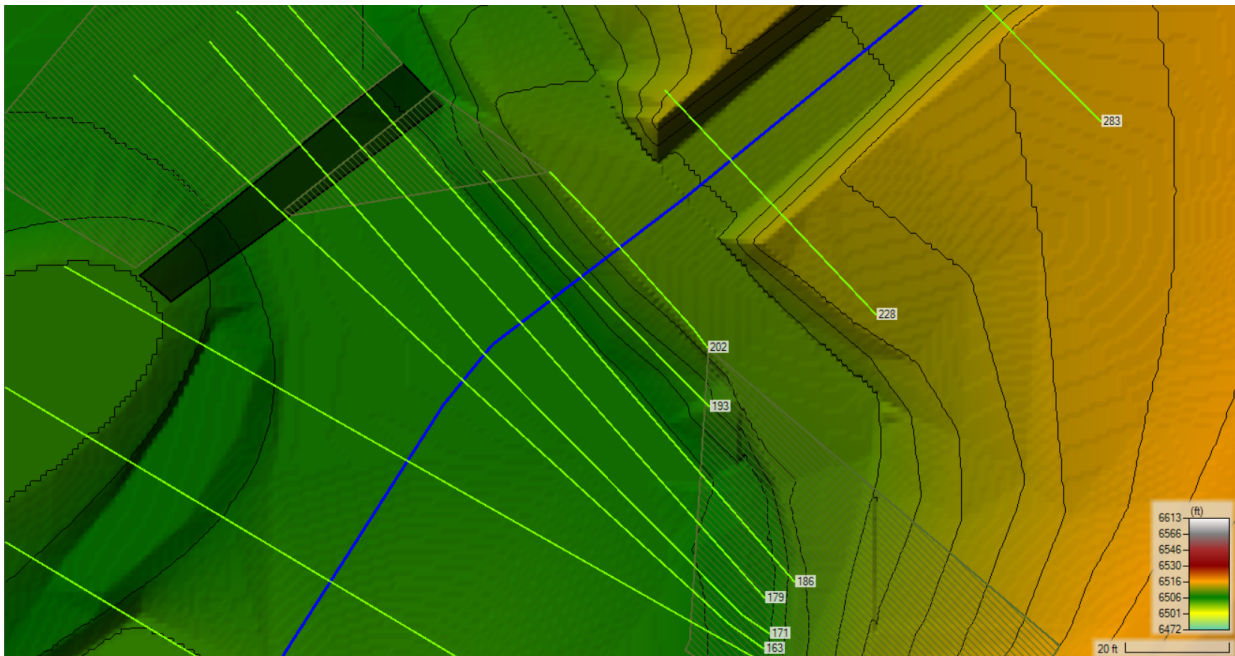

Figure 9: A zoomed-in image of Figure 8 at the location where the jump is estimated to occur.



SCHEDULE E – PROJECT SPECIFIC SPECIAL PROVISIONS

Will follow this page.

SCHEDULE E

PROJECT SPECIFIC SPECIAL PROVISIONS

The **Project Specific Special Provisions** amend or supplement the **General Provisions** of the Construction Contract and other provisions of the Contract Documents as indicated below. All Provisions, which are not so amended or supplemented, remain in full force and effect.

1.0 STANDARD SPECIFICATIONS

1.01 STANDARD SPECIFICATIONS

The **Standard Specifications** for this project shall be the *City of Colorado Springs City Engineering Division General Provisions and Standard Specifications*, (revised March 2005), except as modified hereinafter, which are incorporated in the contract documents by reference as though embodied herein in their entirety.

All contractors on this project are required to have on the job site and utilize the current updated copy of the *City of Colorado Springs City Engineering Division General Provisions and Standard Specifications*.

Copies are available on line through the City of Colorado Springs internet site or for purchase at the cost of \$20.00 from the City of Colorado Springs, Office Services Unit, 30 South Nevada Avenue, Suite L01, Colorado Springs, during regular business hours.

1.02 UTILITY SPECIFICATIONS

Listed below are utility department specifications that should be utilized (current issue or revision) in the construction and/or protection of the respective utility lines.

Hard copies of these specifications are available at Colorado Springs Utilities Development Services, 111 S. Cascade Avenue, Suite 105, Colorado Springs, Colorado 80903. The specifications can also be accessed online at www.csu.org/pages/standards-bulletins.aspx.

UTILITY SPECIFICATIONS

Colorado Springs Utilities
Wastewater Line Extension
And Service Standards

Colorado Springs Utilities
Water Line Extension
And Service Standards

Colorado Springs Utilities
Natural Gas Line Extension
And Service Standards

Colorado Springs Utilities
Electric Line Extension
And Service Standards

2.0 PROJECT SPECIFIC SPECIAL CONDITIONS

2.01 GENERAL

Work to be completed under this contract consists of furnishing all labor, materials, equipment, accessories, and performing all operations to complete the project work in accordance with the Drawings and Specifications.

All work shall be completed in accordance with the *City of Colorado Springs City Engineering Division General Provisions and Standard Specifications*, (revised March 2005,) referred to hereinafter as **Standard Specifications**, except as modified in these **Special Provisions** and the **Project Special Technical Specifications** contained in Schedule F of this document.

The **Contractor** shall visit the jobsite to carefully examine the proposed work. The **Contractor** shall also thoroughly review the Drawings and Specifications. The **Contractor** shall satisfy himself as to the character, quality, and quantities of work to be performed, materials to be furnished, and as to the requirements of these Specifications.

2.02 PROJECT DESCRIPTION

General

The project consists of construction of pond improvements including low flow channels and an outlet structure, installation of riprap channel bed and bank protection, modification of a soil cement flow spreader, modification of a soil cement drop structure, planting and/or seeding and restoration of areas disturbed during construction within approximately 20 acres in and adjacent to Sand Creek Detention Pond No. 2, including approximately 1500 linear feet of Sand Creek upstream of N Carefree Circle. The work is being completed to mitigate sedimentation and degradation within the project site.

2.03 CONTROL OF WORK

In case of any discrepancies in any of the Drawings, Standard Specifications, Special Provisions, and Technical Specifications, the order of precedence is as follows:

- a) Project Specific Special Provisions
- b) Project Special Technical Specifications
- c) Drawings (**Plans**)
 - i. General Drawings
 - ii. Field Markings and Construction Oversight (Figure dimensions will govern over scaled dimensions on all **Plans**)
- d) General Provisions
- e) City of Colorado Springs Engineering Division Standard Specifications
- f) Colorado Springs Utilities Specifications
- g) Digital drawing files if provided to the **Contractor**.

2.04 OWNER

The City of Colorado Springs (hereinafter referred to as **Owner**) shall administer this project including the finalization of any change orders, pay estimates and payments of such, acceptance of work, and other matters as stipulated in these Contract Documents.

2.05 ENGINEER

Engineer refers to the City Engineer of Colorado Springs or designated representative.

2.06 DRAWINGS

The drawings for this project are separate from the Contract Documents book and are entitled "**Sand Creek Detention Pond No. 2**" (hereinafter referred to as the **Construction Plans** or the **Plans**).

2.07 CONSTRUCTION LIMITS

The **Contractor** shall limit construction activities to the "Limits of Construction" as shown in the **Construction Plans** and details and as described in these Special Provisions. Even within the designated limits of disturbance there are existing native trees, shrubs and grasses that are desirable to maintain. To the full extent practical, the **Contractor** shall perform the work in a manner that minimizes damage to the existing vegetation.

THE EXISTING DAM IS A CLASS III (LOW-HAZARD) STATE JURISDICTIONAL DAM. CONSTRUCTION ACTIVITIES ON THE DAM MUST BE LIMITED TO WHAT IS NECESSARY TO INSTALL THE AGGREGATE ACCESS ROAD AND RAISE THE GRADE AT THE TOE OF THE DAM. ANY OTHER DISTURBANCE TO THE DAM MUST BE APPROVED BY A CITY REPRESENTATIVE.

2.08 INSPECTION

At all times, representatives of the **Owner or Owner's Representative** and representatives of other agencies affected by the construction work, and the **Owner or Owner's Representative** shall have the right to enter and inspect any and all parts of the work for compliance with the **Plans** and Specifications.

The **Owner or Owner's Representative** shall decide any and all questions that may arise as to the quality and acceptability of the materials furnished, the work performed, the manner of performance, and the progress of the work. He shall decide all questions that may arise as to the acceptable fulfillment of the contract. The decision of the **Owner or Owner's Representative** shall be final.

The **Contractor** shall give inspection personnel a minimum of forty-eight (48) hours notice prior to needing inspection.

2.09 MATERIAL TESTING

The **Contractor** shall provide all materials testing for Quality Control for the project, which shall be considered incidental to the work. Testing shall be as specified in the City General Provisions Section 108.22 and the Project Special Technical Specifications. The City will provide Quality Assurance testing and reserves the right to reject any work completed by the **Contractor** based on failing tests from either the Quality Assurance or Quality Control provider. All materials tests results shall be provided to the City on a weekly basis, with immediate notification of any failing tests. A final report documenting all tests completed, locations, and results shall be provided to the City upon project completion.

Testing shall be conducted at the following frequencies, which shall supersede any conflicts in the remainder of these specifications:

- Field Compaction Testing for "subgrade preparation, foundation subgrade, wingwall backfill, and cut-off wall backfill" zones-1 test per 500 cubic yards of material
- Field Compaction Testing for remaining fill/subgrade prep-1 test per 1,000 cubic yards of material
- Laboratory Moisture/Density Curve (Proctor): 1 per material type/change in material, and minimum 1 per 10,000 cubic yards of material
- Material Classification Testing (gradation, Atterberg limits): 1 per material type/change in material, and minimum 1 per 10,000 cubic yards of material. Test

- borrow/stockpiled material prior to placement. Minimum 1 test per 10,000 cu yds material and visual changes/variations in material type.
- Grout Testing: a minimum of 2 samples for strength testing shall be prepared per grouted boulder structure, or one per day per grouted boulder structure, whichever is greater. Strength, slump and air-content tests shall be as specified for concrete testing in section 506 of the City General Specifications and section 600 of the Special Technical Specifications. Requirements in the Special Technical Specifications shall supersede those in the City General Specifications.
- Concrete Testing: shall be as specified in section 506 of the City General Specifications and section 600 of the Special Technical Specifications. Requirements in the Special Technical Specifications shall supersede those in the City General Specifications.

2.10 EXISTING UTILITIES

No underground utility locating or utility potholing was performed in the design of this project. The **Contractor** shall field verify the existence and location of all existing utilities which might affect the work and shall notify the **Owner or Owner's Representative** of any utilities not shown on the **Construction Plans**. The utilities shown on the **Construction Plans** are noted for informational purposes only and are believed to be correct. However, additional utilities may be present in the area. The **Contractor** must take sole responsibility for damage to any utility line encountered whether or not shown on the **Plans** and whether or not actually located in the field as shown on the **Plans**. The **Contractor** shall notify the utility companies for field locations prior to the start of construction. This section is supplemental to the **City General Provisions, Section 108.09**.

If the exact location and depth of existing underground utilities are unknown, the **Contractor** shall perform all necessary exploratory excavation at his expense to locate these facilities which may affect the work prior to beginning construction. The **Contractor** shall notify the **Engineer** immediately of any utility discrepancies or conflicts.

The **Contractor** shall inform the **Owner or Owner's Representative** of existing utilities that may need to be relocated. The **Contractor** shall be responsible for contacting, coordinating, and requesting relocations from affected utility owners, and scheduling any relocation in his Work Sequence Plan to meet the Contract Time of Performance.

If the **Contractor** requests that utility companies relocate their utilities for his convenience in construction of any portion of the work, the cost of such shall be at the **Contractor's** expense.

Contract time will not be extended to account for repair of utilities that are damaged by the **Contractor** due to his negligence.

The **Contractor** will be required to contact all utility owners 72 hours prior to beginning excavation and/or grading.

Full compensation for compliance and cooperation, as required by this section, shall be considered to be included in the prices bid for items included on the contract bid schedule and no additional compensation will be provided.

2.11 FEES AND PERMITS

Except as noted below, the **Contractor**, prior to commencing any work, shall secure at his own expense (including fees) all permits required for the performance of the work. Full compensation for compliance and cooperation, as required by this section for all permits except erosion and sediment control, shall be included in the prices bid for mobilization included on the contract bid schedule and no additional compensation will be provided. Erosion and sediment control

permitting shall be included in the price bid for Erosion and Sediment Control included on the contract bid schedule and no additional compensation will be provided.

The **Owner** will acquire authorization to utilize a Nationwide Permit 31 for Maintenance of Existing Flood Control Facilities and a floodplain development permit for the project. The **Contractor** shall perform the work in conformance with the terms of these permits.

The **Contractor** shall obtain at a minimum a

1. **Traffic Control/Access Permit (City and CDOT),**
2. **Contractor Endorsement Letter, Fee, Insurance (Union Pacific Railroad)**
3. **Air Quality Permit (El Paso County)**
4. **A Grading and Erosion Control Permit (City),**
5. **A Construction Stormwater Management Plan (City)**
6. **An Excavation Permit (City),**
7. **A Construction Dewatering Permit (Colorado Department of Public Health and Environment), and**
8. **A Construction Stormwater Discharge Permit (CDPHE).**

The **Contractor** shall comply with all requirements of the permits.

The **Contractor** shall submit required permits to the **Owner** for approval at or prior to the preconstruction meeting. The **Contractor** shall also submit a traffic control plan at the preconstruction meeting for approval by the **Owner**. The **Contractor** shall obtain any additional permits required for the construction of the project. The **Contractor** shall comply with all conditions of all the required permits.

2.12 WASTE MATERIALS

The **Contractor** shall clean up any debris created by his construction activities and shall dispose of the same in suitable trash containers on a daily basis. All debris shall be disposed of off-site at a disposal site approved by the **Owner**. Should the **Contractor** fail to maintain the construction area in a suitable manner after receiving writing notice from the **City**, the **Owner** will have the right to contract with a third party and withhold any amounts incurred from the **Contractor's** payment.

2.13 OPERATIONS WITH OTHERS

The **Owner** reserves the right to have other work performed by other contractors and to permit the public utility companies and others to do work adjacent to or within the site. The **Contractor** shall conduct his operations and shall cooperate with the other parties to minimize interference with this other work.

2.14 CONSTRUCTION STAGING AND ACCESS

Staging areas shall be limited to those shown in the **Plans**. The **Contractor** shall restore the staging areas as shown on the **Plans** for uplands areas at the completion of construction.

Access to the project areas shall be as shown in the **Plans**. The **Contractor** shall be responsible for: establishing and maintaining the access routes during construction; limiting disturbances from vehicles and equipment to the width and length of the access route that is described in these Special Provisions and shown on the **Plans**; and restoring the temporary access routes to match the pre-project condition at the completion of construction. The **Contractor** shall perform temporary removal and in-kind replacement of portions of fences as required. Some utility facilities are present within the construction access route. The **Contractor** shall take measures to protect all facilities in place in accordance with direction from the utility owner. Contractor shall coordinate with utility owner prior to mobilization to review the construction access route.

All areas affected by construction shall be cleaned and restored to native site conditions or better at the completion of the project work. All work and costs associated with the use and restoration of staging and access areas shall be included in the bid price for Mobilization and no additional compensation will be provided. Seeding required to restore the staging area shall be incidental to Mobilization.

2.15 SANITARY FACILITIES

The **Contractor** shall provide suitable temporary sanitary restroom facilities for use by the construction personnel. Wastes collected in the temporary facilities shall be removed and disposed of in a timely and satisfactory manner, as required to maintain the facilities in a sanitary usable condition. The **Contractor** shall maintain the facilities so that any offensive odor is controlled.

Full compensation for compliance and cooperation, as required by this section, shall be included in the prices bid for items included on the contract bid schedule and no additional compensation will be provided.

2.16 CONTRACTOR'S AND OWNERS REPRESENTATIVES

The **Contractor** shall have on the job at all times as his agent, a competent superintendent capable of reading and thoroughly understanding the **Plans** and **Specifications** and being thoroughly experienced in the type of work being performed. The **Owner** will have a representative on the job site periodically to observe work for conformance with the **Plans** and **Specifications** and clarify questions the **Contractor** has relative to the job. The **Contractor** shall provide accurate records of any field changes made during construction.

2.17 DUST, EROSION, AND NOISE CONTROL

The **Contractor** shall be responsible to install sufficient temporary erosion control facilities to minimize erosion in areas impacted by access, staging, and construction activities. The **Contractor** shall repair, at no additional cost to the project, any erosion and washouts that may occur due to the lack of proper erosion control facilities.

The **Contractor** shall use measures to prevent and control dust and mud within the area affected by the project in accordance with applicable permits. No additional compensation will be paid to the **Contractor** for general dust control. ***Vehicle-tracking control mats will be required at the access points to the public and private paved roadways. Removal of vehicle-tracking mats will be accomplished prior to re-vegetation.***

The **Contractor** shall clean off any soil, dirt, or debris tracked onto any adjacent streets. When notified by the **Owner** that the adjacent streets require cleaning, the **Contractor** shall clean the streets within **2 hours** of such notification, or the **Owner** shall arrange to have the streets cleaned and shall deduct the cost of such cleaning from the **Contractor's** payments.

All work and materials associated with installation and maintenance of temporary erosion control facilities until permanent stabilization is achieved will be paid for in the lump sum price bid for temporary erosion and sediment control.

Construction noise shall be limited as required by the City Code and Charter, Chapter 9 – Public Offenses, Article 8.

2.18 TRAFFIC CONTROL AND PEDESTRIAN BARRICADES

The **Contractor** shall furnish all necessary flag persons; erect and maintain warning lights, advance warning signs, detour signs, barricades, temporary fence, and sufficient safeguards around all excavations, embankments, obstructions; and any other work for this project for the

protection of all work being performed and for the safety of the public and pedestrian traffic, as well as bicycles and motor vehicles.

The **Contractor** shall provide adequate temporary construction fencing around active work zones and access routes when hazards to pedestrian traffic exist. The **Contractor** shall provide proper warning signs on existing trails, driveways, and roadways that cross or are a part of temporary access routes, staging areas or work zones.

All signs and barricades shall conform to the **Manual of Uniform Traffic Control Devices** and meet the requirements of **General Provision 105.07 and Section 800 of the Standard Specifications**.

The **Contractor** shall submit three (3) copies of a **Traffic Control Plan** and accepted permit, acceptable to the **Owner**, for review **at or before the Preconstruction Conference**. This plan must provide traffic control at all access points, and when loading and unloading equipment and material in public street right-of-ways.

2.19 WATER CONTROL

Until the **Owner** issues final written acceptance of the project, the **Contractor** shall take every precaution against damage to any part of the project including the adjacent land, vegetation, utilities, paving and structures from any cause, including all surface and subsurface water, whether arising from the execution of work or any other cause. The **Contractor** shall rebuild, repair, restore, replant and make good all damages to any portion of the work due to causes beyond the control of and without the fault of negligence of the **Contractor**, including but not restricted to high water, floods, or acts of God, of the public enemy, or of governmental authorities.

The **Contractor** shall be responsible for the project and shall take such precautions as may be necessary to construct the project in a dry condition and provide for drainage, dewatering, and control of all surface and subsurface water. The term water shall be interpreted as including water in all its forms including, but not limited to, liquid water, snow, and ice. The **Contractor** shall erect any necessary temporary structures or other facilities at his expense to control surface water and groundwater. **The Contractor is advised that he is working in a major drainage course subject to continuous low flow and intermittent flow of significant magnitude. As such, proper management and control of water through the project area will be required to avoid localized flooding, damage to the work and adjacent facilities and properties and/or extensive soil erosion.** At or prior to the **Preconstruction Conference** and prior to beginning any work, the **Contractor** shall submit three (3) copies of a plan for **Water Control and Dewatering** to the **Owner** for review. The **Owner**, at his option, may require the **Contractor** to update the **Water Control Plan** as conditions warrant. The **Contractor** shall acquire a **Construction Dewatering Permit and Stormwater Discharge permit from the Colorado Department of Public Health and Environment**.

The **Contractor** shall carefully evaluate and plan the work and develop a water control plan that is compatible with the work plan and minimizes risks to adjacent properties, facilities and completed and in-progress work.

The **Contractor**, at his expense, shall furnish all necessary equipment and materials required to control the surface and subsurface water in all the areas from start of work through the completion of the total project work. The **Contractor** shall perform all work associated with "Water Control and Dewatering" in accordance with the **Section 920 "Water Control and Dewatering"** included in the Project Special Technical Specifications.

2.20 PROGRESS

If the completion of any part of the work or the delivery of materials is behind the approved schedule, the **Contractor** must submit an updated schedule acceptable to the **Owner** for bringing the work up to meet the anticipated completion date. The **Owner** shall have the right to withhold

progress payments for the work if the **Contractor** fails to update and submit the progress/manpower schedule and reports as specified.

2.21 PRE-CONSTRUCTION CONFERENCE RESPONSIBILITIES

The **Contractor** will attend a **pre-construction meeting** before beginning construction. The purpose of the meeting will be to discuss project issues, scheduling, phasing, environmental concerns, water control, private property issues, pedestrian issues, storm water clean water act, safety, etc., the **Contractor's** designated Superintendent or Supervisor assigned to the project shall attend this meeting. The **Contractor shall**, at a minimum, provide the following materials at or prior to the **Pre-Construction Conference**:

1. Traffic Control and Pedestrian Safety Plan
2. Water Control and Dewatering Plan
3. Construction Dewatering Permit
4. Construction Stormwater Discharge Permit
5. Stormwater Management Plan (if revisions are requested from plan)
6. Construction Schedule and Manpower Report
7. Detailed Construction Method and Phasing Plan for Construction (Refer to 2.31)

The **Plans** are to be reviewed by the **Owner** prior to construction. All issues are to be resolved prior to beginning construction.

2.22 SHOP DRAWINGS

Contractor shall submit all required **Shop Drawings and Product Submittals (digital in PDF format or 3 hard copies)** to the **Owner or Owner's Representative** for review. These include, at a minimum, the following:

1. Test results for any imported riprap, aggregate bedding, grout, concrete, and boulders
2. Geotextiles
3. Seed, mulch, bonded fiber matrix
4. Structural Concrete Mix Design
5. Structural Concrete Form Materials
6. Anti-Graffiti Coating manufacturer's data sheets
7. Structural Concrete Reinforcement Shop Drawings, Certificates, and Manufacturers Literature
8. Structural Steel shop drawings and manufacturer's data sheets
9. Selective Site Demolition Methods and Operations

Owner shall respond to any **Shop Drawings** within 2 weeks of receipt.

2.23 COORDINATION WITH PRIVATE PROPERTY OWNERS

The **Contractor** is not to enter **private property**, outside of the construction easements as shown on the **Plans** unless written access permission from the owner of the property is obtained by the **Contractor** and approved by the **Owner**. All damages to private property shall be immediately repaired to as good or better conditions at no additional cost to the project. The **Contractor** will notify the **Owner** immediately if damages occur to private property.

2.24 MOBILIZATION

The Bid Schedule has an item for mobilization, which may include such items as administration, bonding, and insurance. **Mobilization shall be paid as shown in Section 627 of the Project Special Technical Specifications.**

2.25 DISPOSAL SITE

The **Contractor** is responsible for the removal of all debris, unsuitable material, asphalt, concrete, bushes, portions of trees not used in the work, stumps, remains from clearing and

grubbing, and all other materials not used for the construction of the improvements. Disposal of these materials shall not be measured separately but included in the unit price bid for each applicable item on the bid schedule. The **Contractor** shall designate in writing a disposal site acceptable to the **Owner**. Further, the **Contractor** shall consider the following for hauling suitable or disposing of unsuitable materials:

- ❑ Access to the project beyond the immediate confines of the work area shall be over suitable roadways without violation of any City, County, State, or Federal restrictions for vehicle and truck weights or any other limitation on movement of heavy equipment hauling materials to and from the site.
- ❑ **Violation costs, including fines and repairs to either public or private roadways or appurtenance structures, above or below ground level, shall be at the Contractor's expense.**

Unless otherwise presented in the Bid Schedule, the **Contractor's** cost for loading, hauling, daily cleaning of streets and trails, the disposal of material that must be removed from the site, together with the construction, maintaining and altering of haul roads, dump fees and permits, shall not be paid for separately.

2.26 EXCAVATION AND REPLACEMENT OF UNSUITABLE MATERIAL

Excavation and Replacement of Unsuitable Material is defined in the Technical Specifications. The **Contractor** shall not complete any excavation and replacement of unsuitable material without prior written approval from the **Owner**. Excavation and replacement of unsuitable material shall not be used in lieu of proper dewatering.

2.27 WORK HOURS

Normal work hours are 7:30 AM to 5:30 PM Monday through Friday. Work outside normal hours may be allowed but must be approved in advance in writing by the **Owner**.

2.28 ARCHAEOLOGICAL AND HISTORICAL DISCOVERIES

The **Contractor** is required to inform the **Owner** of any evidence which might suggest to a lay person that archaeological or historic materials may be present in the work area. Upon making such a discovery, the **Contractor** shall do whatever is necessary to avoid disturbing the work area. This could require that the **Contractor's** activities be redirected or stopped until the **Owner** or **Engineer** determines how to proceed.

2.29 CONSTRUCTION DOCUMENTATION

Photographs and Videos

1. Construction photographs will be required on the project illustrating pre-construction, construction, and post-construction conditions.
2. Photographs shall be 3" X 5" size or larger, matte finish, in color and mounted in 3-ring binders.
3. Each photograph shall be marked with date description and identification number.
4. Each photograph must indicate a station reference to work as shown on the **Plans**.
5. The preconstruction photographs shall be delivered to and approved by the **Owner** or **Owner's Representative**, prior to the beginning of construction.
6. Include progress photographs with each pay request. The photos will be a requirement for payment.
7. Digital pictures on a disk may be substituted for the above. However, the pictures must be named as described above.
8. **Contractor** shall procure and provide to the City an overhead drone video of before, during (on at least a monthly basis), and after site conditions along the entire project reach following the same flight path. Any cost associated with this item shall be considered incidental to Mobilization.

Red-line Drawings

The **Contractor** shall maintain a ***red-line set of drawings indicating field changes*** to the design, existing facilities not shown, pertinent construction data, etc. The **Contractor** shall submit a current set of red-line plans to the **Owner** with each pay estimate. The **Contractor** shall submit a complete set of red-line plans, including as-built survey to the **Owner** at the completion of the project. Red-line plans shall be completed and submitted in both CAD (in a version specified by the **Owner**) and PDF.

Construction photographs and videos will not be paid for separately but will be considered incidental to the Bid Item for Mobilization. As-built survey and red-line drawings will be included in the Bid Item for Survey and Red-Line Drawings.

2.30 SPILL KIT

The **Contractor** shall supply and maintain a spill kit on-site. The spill kit shall contain any and all necessary devices to be used in the event of a spill on-site during construction activities. The **Contractor** shall coordinate with the **Owner's** stormwater inspector regarding the site-specific contents of the spill kit. The spill kit shall remain on-site and be available at all times for the **Contractor's** crew. A meeting shall be set up by the **Contractor's** Stormwater Supervisor prior to any construction activities to clarify the uses and implementation of the spill kit.

The spill kit will not be paid for separately but will be considered incidental to the Bid Item for Erosion and Sediment Control.

2.31 CONSTRUCTION METHOD AND PHASING PLAN

The **Contractor** shall submit a construction method and phasing plan detailing the methods and sequence to be utilized in construction of the proposed facilities. The plan is to include the following items:

1. Mobilization
2. Control and routing of base flows, flood flows, and groundwater;
3. Pedestrian, bicycle, and motorized vehicle Traffic Control as it relates to work phasing;
4. Establishment, maintenance, and restoration of access routes;
5. Pond construction;
6. Slope shaping, seeding, and planting;
7. Phasing.

The **Owner** is to review the construction method and phasing plan and have all questions and issues addressed before construction can proceed. All costs associated with preparation and potential revisions to the method and phasing plan will be considered incidental to the price bid for associated items and no separate payment will be provided.

2.32 REQUESTS FOR INFORMATION (RFI)

"Requests for Information" (RFI) sheets shall be completed by the **Contractor** if additional information of clarification is required. The **RFI** shall be submitted to the **Owner** for processing. **Owner** shall respond to any **RFIs** within 5 business days of receipt. Any changes to the **Plans**, specifications, and construction requirements are to be made in writing. No changes will be permitted based on verbal agreements.

2.33 CONSTRUCTION COORDINATION MEETINGS

The **Contractor will conduct weekly construction progress meetings** with the attendance of all pertinent project related personnel. The **Contractor** shall coordinate with the **Owner** as to the location where the meetings are to be held. The **Contractor** shall create the meeting agenda and distribute meeting minutes within 24 hours of meetings.

2.34 CONSTRUCTION STAKING

The **Contractor** shall be responsible for providing grade and horizontal control for the project elements. At the **Owner** or **Engineer's** request, the **Contractor** shall survey grades and elevations to verify design during construction. The **Contractor** shall place stakes with flags at all property corners as specified on the **Plans** to delineate the work limits. The **Contractor** shall protect all existing control points, property corners and monuments. The **Contractor** shall be responsible for replacing any damaged or destroyed monument, property corner or control point. Any cost associated with providing surveying, grade control, or as built documentation is to be included in the Survey bid item.

2.35 CLEAN UP AND REMOVAL OF SEDIMENT DEPOSITS

The **Contractor** shall implement stabilization measures within the project area to control erosion to the extent practical. If sediment or other material from the site migrates downstream of the project area during construction, it shall be removed and disposed of by the **Contractor** without any additional compensation. The **Contractor** is advised to document the existing conditions in the channel and to provide a copy of the documentation to the **Owner** prior to beginning construction.

2.36 MEASUREMENT AND PAYMENT

The provisions for measurement and payment contained in this section replace and/or take precedence over the measurement and payment provisions contained in the **Standard Specifications**.

Payment for work performed by the **Contractor** under these Contract Documents will be made at the approved unit price or lump sum price for each of the items as listed in the bid proposal and measured as hereinafter specified. Such payment shall compensate the **Contractor** for all costs in connection with furnishing all labor, equipment and material required and performing the operations necessary to complete the item in accordance with the contract documents. No partial payment shall be made for ordered, delivered, or stockpiled items.

Any items of work which are called out in the **Plans** and/or the specifications or are typical for the type of construction being accomplished and do not have a specific line item in the bid proposal but which are necessary to complete the work in accordance with the requirements of good and standard practice, such as sub-grade preparation and grading are to be considered as incidental to the construction of the project and the **Contractor's** cost for such work shall be included in the bid price for the related item of work.

The **Contractor** shall accomplish all incidental work essential to the completion of the project, including cleanup and disposal of waste or surplus material without additional cost to the **Owner**. The cleanup and disposal of waste or surplus material shall be performed during construction or as soon after as is reasonably possible to better maintain the safety and aesthetics of the construction area.

The estimated quantities shown in the bid form are estimates only, being given only as the basis for tabulation and evaluation of the bid, and the City does not warrant, expressly or by implication, that the actual amount of work will correspond therewith. The right to increase or decrease the amount of any class or portion of the work or to make changes in the work required as may be deemed necessary is reserved by the City as provided elsewhere in these specifications. Unless otherwise noted in the following bid items descriptions, the basis of payment will be the plan/bid form quantity. The **Contractor** should perform an independent estimate of quantities and bring discrepancies in excess of 10% of the bid quantity to the attention of the **Engineer** before completion of their bid. It should be noted that certain bid items may be included in the Bid Form to establish a unit price should the use of those items become necessary during construction. Allowance will not be made for loss of anticipated profits or additional compensation should the

use of these items be deemed unnecessary. Project survey of existing site conditions was completed in Fall 2021 and Summer 2022 by Merrick & Company with project control as stated on the **Plans**. If the **Contractor** does not believe that the survey adequately represents the current site conditions, **Contractor** may at his expense and prior to submitting a Bid, procure an existing conditions survey to document any changed site conditions and necessary changes to earthwork or other quantities.

BID ITEMS DESCRIPTIONS:

BID ITEM NO. 1: MOBILIZATION (LS)

a. Item Description

Mobilization shall consist of the preparatory work and operations in mobilizing for beginning work on the Project and restoring the site and demobilizing at the end of construction. This work shall include, but not be limited to, those operations necessary for the movement of personnel, equipment, supplies and incidentals to the Project Site, and for the establishment of temporary offices safety equipment and first aid supplies, sanitary and other facilities, as required by these Specifications, and State and local laws and regulations. The costs of bonds, plans, permits and any required insurance and other pre-construction expense necessary for the start of the work, excluding the cost of construction materials, shall also be included in this item.

b. Payment

Payment for the Bid Item shall include but is not limited to full compensation for all labor, equipment, tools and materials necessary to mobilize and obtain permitting, and all other costs incurred or labor and operations which must be performed prior to beginning the other items under the contract. Payment shall be made based on the applicable contract lump sum price for the Bid Item and shall include full compensation for all labor, equipment, tools, and materials necessary to complete the work.

Payment will be according to the following schedule:

1. When 5% of the original contract amount is earned, 20% of the amount bid for mobilization will be paid.
2. When 20% of the original contract amount is earned, an additional 30% of the amount bid for mobilization will be paid.
3. When 35% of the original contract amount is earned, an additional 10% of the amount bid for mobilization will be paid.
4. When 50% of the original contract amount is earned, the remaining 40% of the amount bid for mobilization will be paid.

BID ITEM NO. 2: TRAFFIC CONTROL (LS)

a. Item Description

This item includes all labor, materials, equipment, and tools required to meet the requirements of Section 800 of the **Standard Specifications**.

b. Payment

Payment shall be made as a percentage of the Traffic Control Lump Sum amount equal to the percent-complete-to-date of the balance of the total contract amount less any previous payments for Traffic Control. In no case shall the total amount paid for Traffic Control exceed the Lump Sum shown in the bid schedule. Payments shall be considered full compensation for all labor, equipment, tools, and materials necessary to complete the work.

BID ITEM NO. 3: WATER CONTROL AND DEWATERING (LS)

a. Item Description

This work consists of all temporary measures needed to meet the requirements of Section 2.19 of these Special Provisions and Section 920 of the Project Special Technical Specifications during construction of the project. This bid item includes all the costs for labor, equipment, tools, and materials associated with the work.

b. Payment

The lump sum price will include all of the CONTRACTOR's costs. This BID item includes, but is not limited to:

- 1) Preparing and submitting water control plan for review
- 2) Implementing measures to control surface water and groundwater not paid for under Bid Item ESC-07-001, Temporary Diversion Measure or ESC-16-001. Temporary Slope Drain
- 3) Providing temporary power and sound proofing, as required
- 4) Evaluating, designing, constructing, maintaining, replacing, and monitoring dewatering measures
- 5) Modifying the approved and implemented water control plan as necessary
- 6) Furnishing and installing all materials, sediment basins, diversion measures, slope drains, check dams, pumps, dewater bags, earth embankments, sheet pile, wells, stream crossings or any other material necessary for water control
- 7) Obtaining all required permits
- 8) Monitoring, sampling and analysis, and preparing water quality reports, if required
- 9) Protecting WORK from groundwater, base flows, and storm events
- 10) Providing all other related and necessary labor, equipment, and materials to complete the WORK.

Payment shall be made based on the applicable contract lump sum price for the Bid Item and shall include full compensation for all labor, equipment, tools, and materials necessary to complete the work.

1. When 25% of the of the original contract amount is earned, 34% of the amount bid for water control and dewatering will be paid.
2. When 50% of the of the original contract amount is earned, 33% of the amount bid for water control and dewatering will be paid.
3. When 100% of the of the original contract amount is earned, 33% of the amount bid for water control and dewatering will be paid.

BID ITEM NO. 4: CLEARING AND GRUBBING (AC)

a. Item Description

Clearing and grubbing consists of clearing, grubbing, removing, and disposing of all vegetation, and trees 8" or smaller diameter, as needed to construct the proposed improvements as shown on the **Plans** and as required by the Work and not paid for by other bid items. Trees, vegetation, and objects designated to remain shall be preserved free from injury or defacement as part of this bid item.

b. Payment

Payment will be according to the total acreage cleared and grubbed. Payment for the Bid Item shall include but is not limited to full compensation for all labor, equipment, tools and materials necessary to clear areas as required for site access, staging areas, and construction of the proposed improvements as indicated within the limits of disturbance. Payment shall not be made for areas cleared unnecessarily, and such areas shall be restored at the **Contractor's** expense. Payment shall be made at the applicable contract unit price for the Bid Item and shall include full compensation for all labor, equipment, tools, and materials necessary to complete the work.

BID ITEM NO. 5: EROSION CONTROL (LS)

a. Item Description

Erosion control shall be paid as a lump sum item, regardless of the facilities required to manage erosion in compliance with all permits and regulations.

b. Payment

Payment for this item shall include all earthwork, sediment control means and devices, pipes, temporary culverts, check dams, silt fencing, erosion control logs, vehicle tracking, construction access roads, and all other material, equipment and operations necessary for erosion control measures. This bid item also includes removal of all erosion control measures when the project is complete. Payment shall be made based on the applicable contract lump sum price for the Bid Item and shall include full compensation for all labor, equipment, tools, and materials necessary to complete the work.

Payment will be according to the following schedule:

1. When 25% of the original contract amount is earned, 34% of the bid amount will be paid.
2. When 50% of the original contract amount is earned, 33% of the bid amount will be paid.
3. When 75% of the original contract amount is earned, 33% of the bid amount will be paid.

BID ITEM NO. 6: REMOVAL OF STRUCTURES AND OBSTRUCTIONS (LS)

a. Item Description

This item includes removing and properly disposing offsite miscellaneous metals, handrailing, and other items as noted to be removed that are not covered by another pay item. This work also includes removal of any debris as necessary to complete the work. Items to be removed shall become the property of the **Contractor**.

b. Payment

Payment shall be made on a percent complete basis as concrete or other debris is removed from the site and disposed of by the **Contractor** as approved by the **Engineer**.

BID ITEM NO. 7: CUT SOIL CEMENT (SF)

a. Item Description

This item includes removing and properly disposing offsite existing soil cement to finished grade or plan subgrade elevation as noted on the drawings. Items to be removed shall become the property of the **Contractor**.

b. Payment

Payment shall be made on a square foot basis as soil cement is removed to final elevation, hauled from the site and disposed of by the **Contractor** as approved by the **Engineer**.

BID ITEM NO. 8: REMOVE CONCRETE STRUCTURE (LS)

a. Item Description

This item includes removing and properly salvaging or disposing offsite existing concrete structure as noted to be removed. Items to be removed shall become the property of the **Contractor**. This item shall not be measured but shall be paid on a lump sum basis.

b. Payment

Payment shall be made on a lump sum basis once all concrete structure is removed from the site and disposed of by the **Contractor** as approved by the **Engineer**.

BID ITEM NO. 9: TOPSOIL EXCAVATION AND STOCKPILE (CY)

a. Item Description

The measurement for payment for this item will be the actual number of cubic yards of topsoil excavated and properly stockpiled in accordance with the DRAWINGS and SPECIFICATIONS or as otherwise directed by the ENGINEER. No measurement of this

item will be made unless changes to the CONTRACT DOCUMENTS are made, in which case the ENGINEER will perform measurement of the modified volume. The quantity is based on the neat lines shown on the DRAWINGS and SPECIFICATIONS, and does not account for shrinkage or swell. No additional payment will be made for areas disturbed outside of construction limits or areas within construction limits that are not identified on the DRAWINGS and SPECIFICATIONS to be disturbed, unless approved by the ENGINEER. The unit price will include all of the CONTRACTOR's costs. This BID item includes, but is not limited to:

- 1) Excavating topsoil and vegetation to required depths
- 2) Hauling, stockpiling and segregating topsoil in the off-site stockpile area as directed by the DRAWINGS and SPECIFICATIONS.
- 3) Protecting stockpiles from erosion
- 4) Preparing subgrade
- 5) Providing all other related and necessary labor, equipment, and materials required to complete the WORK

b. Payment

Payment will be based on units completed and accepted.

BID ITEM NO. 10: TOPSOIL, REPLACE (CY)

a. Item Description

The measurement for payment for this item will be the actual number of cubic yards of topsoil replaced in accordance with the DRAWINGS and SPECIFICATIONS or as otherwise directed by the ENGINEER. No measurement of this item will be made unless changes to the CONTRACT DOCUMENTS are made, in which case the ENGINEER will perform measurement of the modified volume. The quantity is based on the neat lines shown on the DRAWINGS and SPECIFICATIONS, and does not account for shrinkage or swell. No additional payment will be made for areas disturbed outside of construction limits or areas within construction limits that are not identified on the DRAWINGS and SPECIFICATIONS to be disturbed, unless approved by the ENGINEER. The unit price will include all of the CONTRACTOR's costs. This BID item includes, but is not limited to:

- 1) Replacing and moistening of topsoil in the designated areas to required depths
- 2) Providing all other related and necessary labor, equipment, and materials required to complete the WORK

b. Payment

Payment will be based on units completed and accepted.

BID ITEM NO. 11: EARTHWORK, EXCAVATION (CY)

a. Item Description

The measurement for payment for this item will be the actual number of cubic yards excavated and used for fill, measured and computed by the average end area method or grid method (difference between existing and finished grade) in accordance with the DRAWINGS and SPECIFICATIONS or as otherwise directed by the ENGINEER. No measurement of this item will be made unless changes to the CONTRACT DOCUMENTS are made, in which case the ENGINEER will perform measurement of the modified volume. The quantity is based on the neat lines shown on the DRAWINGS and does not account for shrinkage or swell, and does not include structural excavation or pre-excavation required to install other BID items. The unit price will include all of the CONTRACTOR's costs. This BID item includes, but is not limited to:

- 1) Excavating, transporting, stockpiling with BMPs, and hauling excavated material to fill areas within PROJECT,
- 2) Cross hauling material
- 3) Removing and hauling deleterious materials
- 4) Providing all other related and necessary labor, equipment, and materials to complete the WORK

b. Payment

Payment shall be based on units completed and accepted.

BID ITEM NO. 12: EARTHWORK, FILL WITH ONSITE MATERIAL (CY)

a. Item Description

The measurement for payment for this item will be the actual number of cubic yards of material used for fill, measured and computed by the average end area method or grid method (difference between existing and finished grade) in accordance with the DRAWINGS and SPECIFICATIONS or as otherwise directed by the ENGINEER. No measurement of this item will be made unless changes to the CONTRACT DOCUMENTS are made, in which case the ENGINEER will perform measurement of the modified volume. The quantity is based on the neat lines shown on the DRAWINGS and does not account for shrinkage or swell, and does not include structural excavation or pre-excavation required to install other BID items. The unit price will include all of the CONTRACTOR's costs. This BID item includes, but is not limited to:

- 1) Placing, reworking, and compacting fill material
- 2) Moistening, drying, and reconditioning material, as necessary, to meet moisture-density requirements
- 3) Surface roughening and terracing BMPs as shown on the DRAWINGS
- 4) Providing all other related and necessary labor, equipment, and materials to complete the WORK

b. Payment

Payment shall be based on units completed and accepted.

BID ITEM NO. 13: EARTHWORK, FILL WITH STOCKPILED MATERIAL (CY)

a. Item Description

The measurement for payment for this item will be the actual number of cubic yards of material used for fill, measured and computed by the average end area method or grid method (difference between existing and finished grade) in accordance with the DRAWINGS and SPECIFICATIONS or as otherwise directed by the ENGINEER. No measurement of this item will be made unless changes to the CONTRACT DOCUMENTS are made, in which case the ENGINEER will perform measurement of the modified volume. The quantity is based on the neat lines shown on the DRAWINGS and does not account for shrinkage or swell, and does not include structural excavation or pre-excavation required to install other BID items. The unit price will include all of the CONTRACTOR's costs. This BID item includes, but is not limited to:

- 1) Transporting stockpiled material from the stockpile location to the fill areas within PROJECT.
- 2) Placing, reworking, and compacting fill material
- 3) Moistening, drying, and reconditioning material, as necessary, to meet moisture-density requirements
- 4) Surface roughening and terracing BMPs as shown on the DRAWINGS
- 5) Providing all other related and necessary labor, equipment, and materials to complete the WORK

b. Payment

Payment shall be based on units completed and accepted.

BID ITEM NO. 14: UPLAND SEED AND MULCH (SF)

BID ITEM NO. 15: WETLAND/RIPARIAN SEED AND MULCH (SF)

a. Item Description

This item includes seeding and mulching as designated on the plans and details. The quantity of seed and mulch to be paid for will be the measured surface area in square feet.

Materials shall be in accordance with the Standard Specifications as modified by the Special Technical Specifications.

b. Payment

Payment shall be made at the applicable contract unit price for the Bid Item and shall be considered full compensation for furnishing and installation of all materials; seeding, reseeding, weeding, and maintenance until final acceptance, and all other items necessary to develop a healthy stand of grass as shown on the drawings and in accordance with the specifications.

BID ITEM NO 16: WETLAND PLUGS (EA)

a. Item Description

Measurement will be made of the actual number of plants placed and accepted at the locations shown on the drawings or as directed by the Owner's Representative, and in accordance with the specifications.

b. Payment

Payment will be made at the unit price bid and shall include: furnishing and installation of all materials including plants, soil amendment, excavation including stones, riprap, etc.; backfill, maintenance until substantial completion, and other items necessary to complete the work as shown on the drawings and in accordance with the specifications.

BID ITEM NO. 17: COTTONWOOD POLES (EA)

a. Item Description

This item includes the harvesting and planting of live cottonwood poles as designated on the plans and details. The quantity of cottonwood poles to be paid for will be measured in the field as the number of planted poles accepted in the field by the Engineer as complying with the plans and specifications.

Harvested stock, materials and planting shall be in accordance with the Standard Specifications as modified by the Special Technical Specifications.

b. Payment

Payment shall be made at the applicable contract unit price for the Bid Item and shall be considered full compensation for all labor, equipment, tools, and materials, and protection of the planted live poles necessary to complete the work including but not limited to harvesting from on-site or off-site locations, transporting, trimming, driving pilot holes, installing poles, tamping, watering, beaver protection, and all other items required to install the cottonwood poles per the plans and specifications.

Bid Item No. 18: DECIDUOUS TREES (2" CAL. B&B) (EA)

a. Item Description

The measurement for payment for this item will be per each tree placed as shown on the BID in accordance with the DRAWINGS and SPECIFICATIONS or as otherwise directed by the ENGINEER. The unit price will include all of the CONTRACTOR's costs. This BID item includes, but is not limited to:

- 1) Furnishing, transporting, and installing all materials, including
- 2) stakes and guying wire
- 3) Excavating
- 4) Adding soil amendments and preparing soil
- 5) Mulching
- 6) Weeding
- 7) Spraying for insect and disease control, as required
- 8) Maintaining trees
- 9) Watering during construction warranty period
- 10) Replacing dead or diseased plants during construction warranty period
- 11) Providing all other related and necessary labor, equipment, and materials to complete the WORK

b. Payment

The accepted quantities will be paid for at the contract unit price per EA of trees planted.

Bid Item No. 19: DECIDUOUS SHRUBS (#5 CONTAINER) (EA)

a. Item Description

The measurement for payment for this item will be per each shrub placed in accordance with the DRAWINGS and SPECIFICATIONS or as otherwise directed by the ENGINEER. The unit price will include all of the CONTRACTOR's costs. This BID item includes, but is not limited to:

- 1) Providing and installing plants
- 2) Excavating
- 3) Preparing soil and adding soil amendments
- 4) Replacing dead or diseased plants during construction warranty period
- 5) Watering during construction warranty period
- 6) Mulching
- 7) Providing all other related and necessary labor, equipment, and materials to complete the WORK

b. Payment

Payment shall be made on a per each basis as shrubs have been planted.

BID ITEM NO. 20: VOID PERMEATED TYPE L RIPRAP (CY)

BID ITEM NO. 22: VOID PERMEATED TYPE M RIPRAP (CY)

a. Bid Item No. 24: Void Permeated Type H Riprap (CY) Item Description

This item includes the Void Permeated Riprap of each type to be placed as indicated in the **Plans** and as directed by the **Engineer**. The quantity of Void Permeated Riprap to be paid for each type for will be measured in the field as the length multiplied by the average width of constructed riprap on the finished face of the riprap less the quantity of Harvested Riprap placed and approved. The face area will be multiplied by the specified depth to determine the pay quantity in cubic yards. This work shall be performed in accordance with Section 626 of the **Special Technical Specifications** and with information in the **Plans**.

b. Payment

Payment shall be made at the applicable contract unit price for the Bid Item multiplied by the field measured quantity less the quantity of Harvested Riprap placed and approved and shall include full compensation for all labor, equipment, hauling, tools, and materials necessary to complete the work. Payment shall include all materials, labor, and equipment required to place and install the Void Permeated Riprap as shown in the contract documents including, but not limited to subgrade preparation, rock materials, permeate material, soil materials not paid for by another Bid Item, mixing, mechanical and hand placement, void fill material, placement of amended topsoil material, and bringing surrounding ground to finished grades.

BID ITEM NO. 21: HARVEST, RESTORE, AND REPLACE VOID-PERMEATED TYPE M RIPRAP (CY)

BID ITEM NO. 23: HARVEST, AMEND, AND REPLACE TYPE H VOID-PERMEATED RIPRAP (CY)

BID ITEM NO. 25: HARVEST, RESTORE, AND REPLACE SOIL TYPE L RIPRAP (CY)

a. Item Description

This item includes the Soil or Void Permeated Riprap of each type to be harvested, restored or amended, and replaced as indicated in the **Plans** and as directed by the **Engineer**. The quantity of Harvested Soil or Void Permeated Riprap to be paid for each type for will be measured in the field as the length multiplied by the average width of riprap on the in-place face of the riprap. The face area will be multiplied by the depth of in-place material to determine the pay quantity in cubic yards. This work shall be performed in accordance with Section 626 of the **Special Technical Specifications** and with information in the **Plans**.

b. Payment

Payment shall be made at the applicable contract unit price for the Bid Item multiplied by the field measured quantity and shall include full compensation for all labor, equipment, hauling, tools, and materials necessary to complete the work. Payment shall include all materials, labor, and equipment required to place and install the Soil or Void Permeated Riprap as shown in the contract documents including, but not limited to subgrade preparation, rock materials, permeate material, soil materials not paid for by another Bid Item, mixing, mechanical and hand placement, void fill material, placement of amended topsoil material, and bringing surrounding ground to finished grades.

BID ITEM NO. 26: SOIL TYPE L RIPRAP (CY)

a. Item Description

This item includes the Soil Riprap of each type to be placed as indicated in the **Plans** and as directed by the **Engineer**. The quantity of Soil Riprap to be paid for each type for will be measured in the field as the length multiplied by the average width of constructed riprap on the finished face of the riprap less the quantity of Harvested Riprap placed and approved. The face area will be multiplied by the specified depth to determine the pay quantity in cubic yards. This work shall be performed in accordance with Section 626 of the **Special Technical Specifications** and with information in the **Plans**.

b. Payment

Payment shall be made at the applicable contract unit price for the Bid Item multiplied by the field measured quantity less the quantity of Harvested Riprap placed and approved and shall include full compensation for all labor, equipment, hauling, tools, and materials necessary to complete the work. Payment shall include all materials, labor, and equipment required to place and install the Soil Riprap as shown in the contract documents including, but not limited to subgrade preparation, rock materials, soil materials not paid for by another Bid Item, mixing, mechanical and hand placement, placement of amended topsoil material, and bringing surrounding ground to finished grades.

BID ITEM NO. 27: GROUTED BOULDERS (CY)

a. Item Description

This item includes all materials, equipment, and labor associated with constructing grouted boulders as shown in the **Plans**. The work shall be performed in accordance with the **Standard Specifications** as modified by Section 626 of the Project Special Technical Specifications.

b. Payment

Payment shall be made at the bid price per cubic yard, and shall include full compensation for all labor, equipment, tools, and materials necessary to construct the structures. Payment for Grouted Boulders shall include all subgrade preparation and fine grading to prepare the site for boulder placement; boulders, placed to the satisfaction of the **Engineer**, all grout, including grout trench, curing, and hauling and placement of materials as required.

BID ITEMS NO. 28 AND 29: STRUCTURAL CONCRETE AND STRUCTURAL CONCRETE WITH INTEGRAL COLOR (CY)

a. Item Description

Concrete will be measured by the cubic yard in accordance with the dimensions shown on the plans. Plan quantities reflect deductions for all voids designed into the structure. This work shall be performed in accordance with Section 600 of the Standard Specifications as modified by the Special Technical Specifications. Payment

The accepted quantities will be paid for at the contract unit price per CY of concrete placed. Payment shall include all materials, labor, and equipment required to place and install the reinforced concrete as shown in the contract documents including, but not limited to subgrade preparation, drainage holes and core, forming, rebar placement, form release, integral color, concrete delivery, installation, curing, blanketing if required, testing, backfill, compaction and bringing surrounding ground to finished grades.

BID ITEM NO. 30: BACKFILL CONCRETE (CY)

a. Item Description

Concrete will be measured by the cubic yard in accordance with the dimensions shown on the plans. Plan quantities reflect deductions for all voids designed into the structure. This work shall be performed in accordance with Section 600 of the Standard Specifications as modified by the Special Technical Specifications. This pay item excludes the concrete apron at the railroad crossing.

b. Payment

The accepted quantities will be paid for at the contract unit price per CY of concrete placed. Payment shall include all materials, labor, and equipment required to place and install the reinforced concrete as shown in the contract documents including, but not limited to subgrade preparation, forming, rebar placement, form release, concrete delivery, installation, curing, blanketing if required, testing, backfill, compaction and bringing surrounding ground to finished grades.

BID ITEM NO. 31: REMOVE 18" RCP (LF)

a. Item Description

Measurement shall be from end to end of the pipe. This item includes the removal and disposal of reinforced concrete pipe at the locations as noted on the plans.

b. Payment

Payment shall be made at the applicable contract unit price for the Bid Item per lineal foot and shall be considered full compensation for all labor, equipment, tools, and materials, required to remove, stockpile, load, transport, and dispose of the pipe.

BID ITEM NO. 32: REMOVE FES – 18" DIAMETER (EA)

a. Item Description

Measurement shall be per each flared end section and toe wall unit. This item includes the removal and disposal of FES at the locations as noted on the plans.

b. Payment

Payment shall be made at the applicable contract unit price for the Bid Item and shall be considered full compensation for all labor, equipment, tools, and materials, required to remove, stockpile, load, transport, and dispose of the FES.

BID ITEM NO 33: SHEET PILE (SF)

a. Item Description

The measurement for payment for this item will be the actual number of square feet placed in accordance with the DRAWINGS and SPECIFICATIONS or as otherwise directed by the ENGINEER. Measurements will be based upon planar square feet (length x width). No payment will be made for sheet pile installed outside the limits of construction shown on the DRAWINGS and SPECIFICATIONS, or for WORK required to repair damage done by the CONTRACTOR's operations.

b. Payment

Payment shall be made at the applicable contract unit price for the Bid Item multiplied by the field measured quantity and shall include full compensation for all labor, equipment, hauling, tools, and materials necessary to complete the work. Payment shall include all materials, labor, and equipment required to place and install the sheet pile as shown in the contract documents including, but not limited to splicing, cutting, driving, removing and replacing pile damaged during installation, constructing and restoring access roads for pile driving equipment and other incidental work required to install the sheet piling, cutting lifting holes, and pre-drilling for installation into bedrock as necessary.

BID ITEM NO 34: SHEET PILE CAP (LF)

a. Item Description

The measurement for payment for this item will be the actual number of linear feet of sheet pile cap placed in accordance with the DRAWINGS and SPECIFICATIONS or as otherwise directed by the ENGINEER. The unit price will include all of the CONTRACTOR's costs. This BID item includes, but is not limited to:

- 1) Excavating and disposing of the material
- 2) Furnishing, forming, and placing concrete, including rebar
- 3) Acquiring, placing, and compacting approved clay material as shown the DRAWINGS
- 4) Installing gasket material as required
- 5) Welding, extension, and splicing, as necessary, to install sheet pile cap according to the DRAWINGS and SPECIFICATIONS
- 6) Providing all other related and necessary labor, equipment, and materials to complete the WORK

b. Payment

The accepted quantities will be paid for at the contract unit price per LF of sheet pile cap placed.

BID ITEM NO 35: GRANITE SAND AGGREGATE (LF)

a. Item Description

The measurement for payment for this item will be the actual number of Lineal feet of granite sand aggregate placed in accordance with the DRAWINGS and SPECIFICATIONS or as otherwise directed by the ENGINEER. The unit price will include all of the CONTRACTOR's costs. This BID item includes, but is not limited to:

- 1) Furnishing, transporting, mixing, and placing all aggregate
- 2) Excavating, preparing subgrade, backfilling, and compacting to the lines and grades shown on the DRAWINGS
- 3) Removing any debris, disposing unsuitable material, and transporting, stockpiling, and placing suitable excess material in fill areas within the PROJECT
- 4) Providing all other related and necessary labor, equipment, and materials to complete the WORK

b. Payment

The accepted quantities will be paid for at the contract unit price per LF of granite sand aggregate placed.

BID ITEM NO 36: REMOVE TREE (>8") (EA)

a. Item Description

The measurement for payment for this item will be the actual number of trees removed in accordance with the DRAWINGS and SPECIFICATIONS or as otherwise directed by the ENGINEER. The unit price will include all of the CONTRACTOR's costs. This BID item includes, but is not limited to:

- 1) Removing, hauling, and disposing of structures and obstructions including, but not limited to, existing pipe, culverts, inlets, concrete, asphalt, and any structures and obstructions that interfere with the WORK
- 2) Backfilling and compacting after removal of structures and obstructions
- 3) Moisture conditioning of suitable backfill material
- 4) Restoring area, as required
- 5) Providing all other related and necessary labor, equipment, and materials to complete the WORK

b. Payment

The accepted quantities will be paid for at the contract unit price per tree removed.

BID ITEM NO 37: REMOVABLE STOP LOGS SYSTEM (LS)

a. Item Description

The measurement for payment for this item will be paid as a lump sum for any labor, equipment, and materials required for this item. The unit price will include all of the CONTRACTOR's costs. This BID item includes, but is not limited to:

- 1) Furnishing and installing stop log system, embedded items, posts, stop logs and appurtenances as shown on DRAWINGS.
- 2) Coordination with foundation/wall work at outlet structure.
- 3) Providing all other related and necessary labor, equipment, and materials to complete the WORK

b. Payment

Payment shall be made on a lump sum basis once all stop log systems have been installed.

BID ITEM NO 38: STRUCTURAL AESTHETIC TREATMENTS (LS)

a. Item Description

This item will not be measured but will be paid on a lump sum basis for structural aesthetic treatment placed on the structural concrete of structures in accordance with the DRAWINGS and SPECIFICATIONS or as otherwise directed by the ENGINEER. The lump sum price will include all of the CONTRACTOR's costs. This BID item includes, but is not limited to:

- 1) Treating, patching cleaning and preparing concrete surfaces prior to treatment
- 2) Furnishing and applying the treatment, including stain, decorative joints, and formliner,
- 3) Providing all other related and necessary labor, equipment, and materials to complete the WORK

b. Payment

Payment shall be made on a lump sum basis once all Structural Aesthetic Treatments have been installed.

BID ITEM NO 39: RAILING (LF)

a. Item Description

The measurement for payment for this item will be the actual number of linear feet of handrail placed in accordance with the DRAWINGS and SPECIFICATIONS or as otherwise directed by the ENGINEER. The unit price will include all of the CONTRACTOR's costs. This BID item includes, but is not limited to:

- 1) Furnishing, measuring, fabricating, welding, blasting, priming, coating, painting, and installing handrail
- 2) Providing hardware necessary to anchor handrail
- 3) Providing all other related and necessary labor, equipment, and materials to complete the WORK

b. Payment

The accepted quantities will be paid for at the contract unit price per LF of Handrail placed.

BID ITEM NO 40: WATER FEATURE BOULDER (EA)

a. Item Description

The measurement for payment for this item will be the actual number of Water Feature Boulders placed in accordance with the DRAWINGS and SPECIFICATIONS or as otherwise directed by the ENGINEER. The unit price will include all of the CONTRACTOR's costs. This BID item includes, but is not limited to providing all related and necessary labor, equipment, boulders, dowels, and other materials required to complete the WORK.

b. Payment

The accepted quantities will be paid for at the contract unit price per each of Water Features Boulders placed.

BID ITEM NO 41: TRUEGRID PAVERS (SY)

a. Item Description

The measurement for payment for this item will be the actual number of square yards of Truegrid Pavers placed as part of the Truegrid Pavers Perimeter Access Road, Truegrid Pavers Access Roads in accordance with the DRAWINGS and SPECIFICATIONS or as otherwise directed by the ENGINEER. This BID item includes, but is not limited to providing all related and necessary labor, equipment, and materials to complete the WORK.

b. Payment

The accepted quantities will be paid for at the contract unit price per SY of Truegrid Pavers placed.

BID ITEM NO 42: MUCK EXCAVATION (CY)

a. Item Description

The measurement for payment for this item will be the actual number of cubic yards of material removed beyond what is required for the construction of the improvements in accordance with the DRAWINGS and SPECIFICATIONS or as otherwise directed by the ENGINEER. Measurement will be based upon actual field measurements and calculated volumes (no allowance for shrinkage or swell). The unit price will include all of the CONTRACTOR's costs. This BID item will be only at the direction of the ENGINEER. This BID item includes, but is not limited to: 1) Excavating, hauling, and disposing material off site 2) Replacing with approved material 3) Placing approved geotextile 4) Providing all other related and necessary labor, equipment, and materials to complete the WORK.

b. Payment

Payment will be based on units completed and accepted.

BID ITEM NO. 43: FLOOD WARNING SIGN (EA)

a. Item Description

The measurement for payment for this item will be per each Flood Warning Sign placed in accordance with the DRAWINGS and SPECIFICATIONS or as otherwise directed by the ENGINEER. The unit price will include all of the CONTRACTOR's costs. This BID item includes, but is not limited to:

- 1) Coordination with ENGINEER and OWNER regarding overall sign content, layout, and placement
- 2) Submitting proof for review and approval prior to sign production
- 3) Furnishing, transporting and installing all materials including sign supports, brackets, posts, bracing, concrete, and any necessary hardware
- 4) Excavation and compaction
- 5) Providing all other related and necessary labor, equipment, and materials to complete the WORK.

b. Payment

Payment will be made at the contract unit price based on units completed and accepted.

BID ITEM NO 44: FORCE ACCOUNT (EA)

a. Item Description

If additional work arises that is necessary to accomplish the scope of work of the contract and is not identified elsewhere in the contract documents, the ENGINEER may authorize work under a force account basis. Payment will be made on a time and materials basis necessary to complete the authorized work. Before any work is authorized by the ENGINEER, the CONTRACTOR and ENGINEER shall agree in writing as to the rate for all employee wages, and material and equipment costs that may be necessary to complete the authorized work.

b. Measurement

Daily, the CONTRACTOR and the ENGINEER shall compare and agree upon the records of labor, equipment, and materials used for the force account work.

c. Payment

To receive payment, the CONTRACTOR shall provide itemized statements of all costs of such force account work detailed as follows:

- Name, classification, date, daily hours, total hours, wage rate, and extensions thereof for each worker and foreman;
- Quantities of materials, prices, and extensions thereof and transportation costs for materials. Attach invoices for all materials used or consumed. If the CONTRACTOR takes the materials from its own inventory, provide certification that:
 - The Material was taken from inventory;
 - The quantity claimed was actually used; and
 - The price and transportation costs claimed represent the Contractor's actual costs; and
- Designations, dates, daily hours, total hours, rental rates, and extensions thereof for each unit of equipment and transportation costs for equipment.



SCHEDULE F – PROJECT SPECIAL TECHNICAL SPECIFICATIONS

Will follow this page.

SCHEDULE F
PROJECT SPECIAL TECHNICAL SPECIFICATIONS

The Technical Specifications for this project shall be the City of Colorado Springs; Engineering Division "Standard Specifications" (herein referenced as Standard Specifications) revised March 2005. The following Special Technical Specifications take precedence over, supplement, or modify the Standard Specifications.

INDEX OF REVISIONS AND ADDITIONS

SECTION REVISED OR ADDED

600	Structural Concrete
617	Steel Sheet Pile
618	Concrete Forming
619	Reinforcement
620	Drainage Channels
624	Riprap and Grouted Riprap Channel Construction
626	Rock
627	Mobilization
640	Structural Steel, Miscellaneous Metalwork and Embedments
650	Selective Site Demolition
900	Seeding, Fertilizer, Blanket, and Mulching
901	Cottonwood Poles
902	Plantings
910	Erosion and Sediment Control
920	Water Control and Dewatering
925	Clearing and Grubbing
950	Construction Surveying

PROJECT SPECIAL TECHNICAL SPECIFICATIONS

REVISION OF SECTION 600 Structural Concrete

Replace section 600 with the following:

PART 1 GENERAL

600.1.01 DESCRIPTION:

- A. This section covers cast-in-place concrete, including furnishing materials, transporting, placing, finishing, curing and other appurtenant items of construction.
- B. Inform Engineer at least 2 weeks in advance of time and places at which Contractor intends to place concrete. All preparation work for concrete placements shall be substantially completed at least 2 workdays prior to the scheduled start of concrete placement to allow for the Engineer's review and any necessary corrections.

600.1.02 QUALITY ASSURANCE:

- A. Reference standards.
 - 1. Except as noted or modified in this Section, all concrete materials, transporting, placing, finishing and curing shall conform to requirements of the latest and current versions of following standards:
 - a. American Concrete Institute Standards (ACI)
 - 1) 117 Specification for Tolerances for Concrete Construction and Materials
 - 2) 211.1 Standard Practice for Selecting Proportions for Normal, Heavyweight, and Mass Concrete.
 - 3) 301 Specifications for Concrete Construction .
 - 4) 304 Recommended Practice for Measuring, Mixing, Transporting, and Placing Concrete.
 - 5) 304.2 Placing Concrete by Pumping Methods.
 - 6) 305 Recommended Practice for Hot Weather Concreting.
 - 7) 306 Recommended Practice for Cold Weather Concreting.
 - 8) 308 Standard Practice for Curing Concrete.
 - 9) 309 Recommended Practice for Consolidation of Concrete.
 - 10) 350 Code Requirements for Environmental Engineering Concrete Structures.
 - b. American Society for Testing and Materials (ASTM).
 - 1) C94 Standard Specification for Ready Mixed Concrete
- B. Contractor shall keep at least one copy of above listed ACI publications, latest edition, in project field office at all times.
- C. Any material or operation specified by reference to the published specifications of a manufacturer shall be complied with unless directed otherwise by the Engineer.
- D. In case of a conflict between the referenced specifications or standards and this Specification, the one having the more stringent requirements, as determined by the Engineer, shall govern.
- E. Architectural Requirements

1. The Contractor shall submit details of the forming system to be used for the walls including details of formwork, form liner, form ties, thru bolts, rustications, finishing techniques and other items used in the construction of the wall. An elevation of the wall showing the layout of the formwork, form liner, form ties, chamfers, and other formwork details shall be submitted. An aesthetically pleasing layout and finished surface for the wall shall be provided.
2. Prior to construction the Contractor shall construct a sample panel of the proposed construction for the Engineer's approval. The panel shall be approximately 6 ft long by 4 ft high and of the same construction as the proposed wall. The sample panel shall show the workmanship, form liner, joints, form ties, color and texture to be used for the wall. The accepted panel shall form the standard for accepted finished work on the project.

600.1.03 SUBMITTALS: All submittals shall be made in accordance with Project Special Provisions Section 2.22. Mix designs, shop drawings and catalog information shall be submitted for related equipment and components, in order to show that concrete and items selected and to be installed by the Contractor generally conform to the Contract Documents. Submittal information includes, but is not necessarily limited to the following:

A. Miscellaneous product information.

1. Catalog information and shop drawings for: waterstops, admixtures, bonding agents, membrane curing compound, joint sealer, embedded items, non-shrink grout, wedge-type expansion anchors, and other concrete appurtenances.

B. Proposed concrete mix design. (Note: Contractor shall be responsible for fully informing the concrete supplier of all specification requirements regarding the concrete mix before the proposed mix design is submitted.)

1. The proportions of ingredients shall be selected to produce the proper workability (slump), durability (air content), strength, maximum water-cementitious materials ratio, time of set and other required properties of Sections 2.01 and 2.02.

The proportion of ingredients shall be such as to produce a mixture with slump and durability that will work readily into the corners and angles of the forms and around reinforcement by the methods of placing and consolidation employed on the work. Do not permit the materials to segregate or excessive free water to collect on the surface.

An independent testing laboratory acceptable to the Engineer shall perform concrete trial mixtures and testing. The costs of the mix designs and testing shall be borne by the Contractor.

submitted concrete mixture will not receive final approval until a sample panel has been constructed and approved by the Engineer and Landscape Architect.

2. Prior to commencing concrete work, submit and obtain Engineer's review of certified test reports describing proposed concrete mix design, which shall be prepared in compliance with ACI Standard 301, with concrete proportions established on the basis of previous field experience or laboratory trial batches, except as modified herein. Test reports shall also include:
 - a. Fine aggregates - Source, type, gradation, deleterious substances and bulk specific gravity on basis of weight of saturated surface-dry aggregate. ASTM C 128.
 - b. Coarse aggregate - Source, type, gradation, deleterious substances and bulk specific gravity on basis of weight of saturated surface-dry aggregate. ASTM C 127.

- c. Ratio of fine to total aggregates.
- d. Weight (saturated surface-dry) of each aggregate per cubic yard.
- e. Total water content in gallons per cubic yard.
- f. Slump on which design is based.
- g. Brand, type and quantity of cement.
- h. Brand, type and quantity of admixtures.
- i. Water-cementitious materials ratio (shall be not greater than specified in Part 2.02).
- j. Air content (which shall be within the upper half of the allowable range).
- k. For the laboratory trial batches method, the determination of the cementitious materials content necessary to attain the required strength and other properties, without exceeding the maximum water-cementitious materials ratio, shall be by preliminary tests in accordance with the following procedures:

Concrete trial mixtures having proportions and consistency suitable for the work shall be made using at least three different cementitious materials contents which will produce a range in strengths encompassing those required for the work.

Proportions of ingredients shall be determined and tests conducted in accordance with the basic relationships and procedures outlined in "Recommended Practice for Selecting Proportions for Normal and Heavy-Weight Concrete (Part I):" (ACI 211.1).

For each cementitious materials content, at least three specimens for each age to be tested shall be made and cured in accordance with "Method of Making and Curing Concrete Compression and Flexure Test Specimens in the Laboratory" (ASTM C 192) and tested for strength at 1, 7, and 28 days. Tests shall be conducted in accordance with "Method of Test of Compressive Strength of Molded Concrete Cylinders" (ASTM C 39).

From the results of these tests, a curve shall be plotted showing the relationship between cementitious materials content and the average 28-day compressive strength. The minimum cementitious materials content to be used shall be that value shown by the curve to produce a strength of at least 1500 psi in 24 hours and at least 1200 psi greater than the 28-day strength specified. In any case, the minimum cementitious materials content shall not be less than that specified in Part 2.02.

If the previous field experience method is used in proportioning, the strengths shall be in compliance with ACI 301. In addition, the Contractor shall demonstrate the ability of the proposed mixture proportions to produce concrete meeting all the requirements of these Specifications. Field test records must be acceptable to the Engineer to use this method.

- 3. In addition to the test data described above, when it is expected that concrete will be placed under hot weather concrete conditions as defined in Section 600, Part 1.06.C, trial batches shall be tested at the maximum temperature that the concrete is expected to be placed. Alternatively, sufficient records may be submitted that show field concrete performance under these temperatures and which are acceptable to Engineer. For provisions for concrete placed under cold weather, see Part 1.05.B

C. Cylinder compression test reports.

- 1. Submit 2 copies of certified test reports to Engineer for 1.03.B.2.K.

D. Ready-mix delivery tickets.

1. Submit delivery tickets for each load at time of delivery indicating following:
 - a. Quantity delivered with Mix Identification Number.
 - b. Quantity of each material in batch.
 - c. Outdoor temperature in shade.
 - d. Time at which water was added.
 - e. Elapsed time between when water was added and concrete load was in place.
 - f. Amounts of initial and supplemental water added, including any corrections for water in aggregate. Note: Total water amount shall result in a water-cementitious materials ratio not greater than the maximum permissible.
 - g. Name of individual authorizing supplemental water.
 - h. Numerical sequence of delivery by indicating cumulative yardage delivered on each ticket.

600.1.04 PRODUCT DELIVERY, STORAGE AND HANDLING:

A. Cementitious materials.

1. Store in weather-tight enclosures and protect against dampness, contamination and warehouse set.
2. Do not use cementitious materials that have become caked or lumpy.

B. Aggregates.

1. Stockpile to prevent excessive segregation, or contamination with other materials or other sizes of aggregates.
2. Use only one supply source for each aggregate stockpile.
3. The bottom 6 in. of all aggregate piles in contact with ground shall not be used.
4. Frozen or partially frozen aggregates shall not be used.

C. Admixtures.

1. Store to prevent contamination, evaporation, or damage.
2. Protect liquid admixtures from freezing or harmful temperature ranges.
3. Agitate emulsions prior to use.

D. Rubber and plastic materials.

1. Store in cool place away from direct sunlight.

E. Mixing and transporting ready-mixed concrete.

1. Maximum elapsed time from time water is added to mix until concrete is in place shall not exceed 1-1/2 hours when concrete is transported in revolving drum truck bodies unless all other provisions of these specifications can be met, including maximum water-cementitious materials ratio, workability, strength and air content. Comply with ASTM C 94.

2. Do not use concrete transported without continuous agitation if the elapsed period between the time the concrete is mixed and the time it is placed is greater than 30 minutes. With the Engineer's approval, an approved retarding admixture may be used at the rate prescribed in Part 2.01.D.6. Also with the Engineer's approval, the mixed-to-placed time period may be extended an additional 30 minutes.
3. Do not use concrete transported with agitation when the time between start of mixing and placement is more than 90 minutes.
4. Deliver and handle concrete in a manner that will:
 - a. Prevent objectionable segregation or damage to the concrete, and
 - b. Facilitate placing with a minimum of handling.
5. Thoroughly clean and flush the compartment in which the concrete is transported to the work at intervals necessary to ensure hardened concrete will not accumulate in the compartment. Discharge flushing water from the compartment before it is charged with the next batch.
6. Obtain Engineer's approval for plant equipment, operation, and procedures.

600.1.05 JOB CONDITIONS:

A. Environmental requirements:

1. Do not place concrete during rain, sleet, or snow unless adequate protection is provided and Engineer's approval is obtained.
2. Do not allow rainwater to increase mixing water or damage surface finish.
3. For cold or hot weather concreting conditions, lab cured cylinder tests may not be an accurate indication of field achieved strengths. Under these weather conditions, the Engineer may require job cured cylinder breaks to determine field strength (cylinders to be job cured in same manner as the in-place concrete.) The Contractor shall pay for testing. Refer to Section 600, part 3.10 for related items to be furnished by Contractor. If cold or hot weather concreting practices specified in Sections 1.06.B and 1.06.C are not adhered to, the Engineer may require Contractor, at Contractor's expense, to provide additional pullout tests in accordance with ASTM C 900, job cured cylinder tests, or 2-inch diameter cored samples from areas in question to determine field strengths achieved.
4. Changes in temperature of the concrete shall be as uniform as possible and shall not exceed 10 Degrees F. in any 1-hour or 45 Degrees F. in any 24-hour period.

B. Cold Weather Concreting. Conform to ACI 306, "Cold Weather Concreting" in addition to this specification.

1. Temperature of concrete when placed shall not be less than following:
Minimum Concrete Temp, Degrees F

Air Temp. Degrees F	Sections with least dimension	
	Under 12 in.	12 in. and Over
30 to 45	60	50
0 to 30	65	55
Below 0	70	60

If water or aggregate has been heated, the water and aggregate shall be combined in the mixer before cementitious materials are added. Cementitious materials shall not be added to mixture of water and aggregate when the temperature of the mixture is greater than 95°F.

2. When placed, heated concrete shall not be warmer than 80°F.
3. Prior to placing concrete, all ice, snow, surface and subsurface frost shall be removed, and temperature of surfaces to be in contact with new concrete, including subgrade materials and massive embedments such as rock, shall be raised to a minimum of 35°F and a maximum of 60°F. The entire mass of all massive embedments must be raised to this temperature range.
4. Protect concrete from freezing during specified curing period. See Part 3.09, Curing, for temperature to be maintained during initial curing period.
5. When the mean daily temperature of the atmosphere is less than 40°F, forms shall be left in place a minimum of 5 days to aid in retaining heat.
6. Heated enclosures shall be strong and windproof to insure adequate protection of corners, edges and thin sections.
7. Do not permit heating units to locally heat or dry concrete.
8. Do not use combustion heaters during first 24 hours unless concrete is protected from exposure to exhaust gases, which contain carbon dioxide.
9. If air temperatures drop below 35°F., the Contractor shall install a high-low temperature gauge into the most exposed portion of concrete during the curing protection period. The gauge shall be equipped to register the lowest overnight temperature. If the concrete temperature drops below the specified temperature, the curing period shall be extended until the degree-days (Part 3.09) are satisfied.
10. Refer to ACI 306 for further requirements.

C. Hot Weather Concreting: Conform to ACI 305, "Hot Weather Concreting" in addition to this specification.

1. Take precautions when ambient air temperature is 90°F or above. These measures may include installation of windbreaks, shading, fog spraying, sprinkling, ponding, or wet covering of a light color. If daytime highs are expected to exceed 100°F, floor and roof slab concrete shall be placed overnight, with placement commencing not prior to 3 hours before sunset.
2. Temperature of concrete when placed shall not exceed 85°F.
3. Cool forms and reinforcing to a maximum of 90°F by spraying with water prior to placing concrete.
4. Do not use cementitious materials that have reached a temperature of 105°F or more at the time they enter the concrete mix.
5. Prevent plastic shrinkage cracking due to rapid evaporation of moisture.
6. Do not place concrete when evaporation rate (actual or anticipated) is 1.0 kg per square m per hour or above, as determined by Figure 2.1.5 of ACI 305.
7. Set-retarding and water-reducing admixtures may be used when the ambient air temperature is 90°F or above to offset accelerating effects of high temperature.

8. Refer to ACI 305 for further requirements.
- D. Protection from Mechanical Injury: During the curing period, the concrete shall be protected from damaging mechanical disturbances particularly load stresses, heavy shock and excessive vibration. All finished concrete surfaces shall be protected from damage caused by construction equipment, materials, or methods and by rain or running water. Self-supporting structures shall not be loaded in such a way as to over-stress the concrete.

PART 2 PRODUCTS

600.2.01 CONCRETE MATERIALS:

- A. Cement shall conform to the "Standard Specification for Portland Cement," ASTM C 150, Type II low-alkali. Once cement type is chosen, the type and source shall remain the same throughout the project.
1. Fly ash shall be Class F (ASTM C 618).
- B. Aggregates.
1. Fine aggregate - ASTM C 33.
 2. Coarse aggregate - ASTM C 33 Size No. 57 or 67.
 3. Once aggregates are chosen, the same source and type of aggregates shall be used throughout the project.
- C. Water.
1. Shall be clean, fresh and free from injurious amounts of oils, acids, alkalis, salts, organic materials, or other substances that may be deleterious to concrete or reinforcement.
- D. Admixtures.
1. Use only as specified or reviewed and acceptable to Engineer.
 2. Include any admixtures to be used in the proposed concrete mix designs. Use only admixtures which are compatible with each other and adjust required dosages accordingly.
 3. Prohibited Admixtures: Calcium chloride, thiocyanates or admixtures containing more than 0.05% chloride ions are not permitted.
 4. Air entraining Agent: ASTM C260. Use BASF (Master Builders) Micro- Air Air-entraining admixture or equal approved by the Engineer.
 5. Water Reducing and Retarding Admixtures: ASTM C494. Contractor shall be responsible for its use and application of the proper dosage rate. It may also be necessary to adjust the quantity of air entraining agent. When fly ash is used in the concrete, the dosage rate shall be applied to both the cement and fly ash combined. Water reducing admixture shall be added at the plant and shall be Pozzoloth 322N by BASF (Master Builders) or approved equal acceptable to the Engineer. Use retarders only as specified or with the Engineer's approval.

6. Mid-Range Water-Reducing Admixture: ASTM C494. Polyheed 1025 by BASF (Master Builders) or equal approved by the Engineer.
7. High Range Water-Reducing Admixture (Superplasticizer): "Eucon 37" by the Euclid Chemical Co., (HRWR) "Rheobuild 1000" by BASF (Master Builders) or "Sikament" by Sika Chemical Corp. The admixture shall conform to ASTM C494, Type F or G, and not contain more chloride ions than are present in municipal drinking water.

E. Tests for Chloride Ions.

1. For all concrete in which aluminum or galvanized metal is to be embedded, it shall be demonstrated by tests in accordance with AASHTO T-260 that the hardened concrete, including the aggregates, cementitious materials and any admixtures used, will not contain more than 0.06 percent water soluble chloride ions by weight of cement.

600.2.02 CONCRETE PRODUCTION:

A. Ready-mixed concrete.

1. Mixed and delivered, ASTM C 94.
2. Retempering. Indiscriminate addition of water to increase slump shall be prohibited.

Concrete shall be mixed only in quantities required for immediate use. Concrete that has partially set shall not be retempered but shall be discarded.

When concrete arrives at the project with slump below that suitable for placing, first the concrete shall be remixed for at least one minute at mixing speed. If the slump is still too low, water may be added only if the maximum permissible water-cementitious materials ratio is not exceeded, the maximum slump is not exceeded, and the temperature of the concrete is less than 90°F. The water must be incorporated by additional mixing equal to at least half of the total mixing required. The Engineer must review such addition.

B. Batching and mixing equipment.

1. Conform to "Recommended Practice for Measuring, Mixing, Transporting and Placing Concrete," ACI 304.

C. Proportioning.

1. Proportion ingredients to produce a well-graded mix of high density and maximum workability consistent with the accepted mix design.
2. Entrained air, $6 \pm 1\frac{1}{2}$ percent for ASTM C 33 Size 67 or 57 coarse aggregate. Refer to ACI 301 for air entrainment required for other coarse aggregate sizes.
3. Refer to Part 1.04.E for mixing and transporting ready-mixed concrete requirements.
4. Strength and General Requirements.

Design and proportion concrete to meet the following minimum compressive strengths and other criteria:

<u>Location</u>	<u>Design Strength 28-Day (psi)</u>	<u>ASTM C 33 Aggregate Size No.</u>	<u>Slump Inches ± 1.5 in.</u>	<u>Minimum Cement Content lb/yd3</u>	<u>Fly Ash Content lb/yd3</u>	<u>Maximum W-C Materials Ratio*</u>
Structural Concrete	4500	57 or 67	3"min-5"max	tbd***	tbd***	0.42
Path Concrete**	4000	57 or 67	4	520	90	0.40
Concrete Fill Material	1500	57 or 67	2	tbd***	tbd***	0.33

*The maximum water-cementitious materials ratio by weight, which shall be based on all water in the mix, including correction for moisture in aggregates, and shall be based on the total cementitious materials including cement and fly ash, if any.

**Path concrete includes walks, trails, and all exterior associated concrete flatwork areas.

*** To be determined in mix design. The maximum percentage of flyash shall be 20%.

Admixtures Required Within this Specification (May be required in other Specifications, does not include admixtures related to mix design.)				
Type	Fibrous Concrete Reinforcement	Color Additive	Anti-Washout Admixture	Other
Structural	None	None	None	
Path	None	None	None	
Concrete Fill Material	None	None	None	
Grout – for Grouted Rock & Boulders	See Rock Specification	See Rock Specification	See Rock Specification	See Rock Specification

600.2.03 CONCRETE ACCESSORY MATERIALS:

A. Curing Materials.

1. Sheet material: ASTM C 171. Sheet material shall not be used on colored concrete.
2. Liquid membrane: membrane-curing compound shall be in accordance with ASTM C 309. Membrane curing compound shall be sprayable, 18% minimum solids content, MasterKure 123 or equivalent acceptable to the Engineer. The concrete will have a stain per the Landscape Architect. The curing compound shall be removed prior to application of the stain in a method approved by the Engineer and acceptable to the stain manufacturer.

B. Joint Sealers.

1. Joint Sealer: Joints indicated on Drawings, shall be sealed with a polyurethane joint sealer material of uniform, non-sag or self-leveling consistency as indicated. The sealant shall, when installed, tenaciously adhere to primed concrete surfaces and shall remain permanently elastomeric.

The material shall be of a type that will, when properly installed, effectively and permanently seal joints subject to minor movements. Install with primer and cure in accordance with the manufacturer's instructions and recommendations.

Except as noted on the Drawings, joint sealer shall be Sikaflex 2C-NS or 2C-SL Elastic Sealant/Adhesive, as manufactured by Sika Chemical Corporation or other material acceptable to the Engineer. Add color as required to match adjacent surfaces where exposed to view.

- C. Non-Shrink Grout: Non-shrink grout shall be "Masterflow 713" or equivalent acceptable to the Engineer. Grouts with iron filings are not acceptable. The grout shall be compatible with the surface to be bonded.
- D. Epoxy Bonding Agent: Bonding agent shall be a two-component moisture insensitive epoxy adhesive, Sikadur 32, Hi-Mod or equivalent acceptable to the Engineer.
- E. Expansion Joint Filler Material: Joint filler material shall be closed cell neoprene or rubber conforming to ASTM D 1056, Grade 2A3. Material shall be glued securely to concrete surfaces.
- F. Sand-Cement Grout: Sand-cement grout, where specified, shall be a mixture of portland cement, sand and water with a maximum water-cement ratio of 0.38 by weight. The cement used shall be of the same type and source as used in the other concrete on this project. The grout shall have a consistency similar to thick paint.
- G. Concrete Support Blocks: Concrete support blocks for the floor reinforcement and the support of the vertical reinforcement at the base of the wall shall be a mixture of portland cement, sand and water with a maximum water-cement ratio of 0.38 by weight. The cement used shall be of the same type and source as used in the other concrete on this project.
- H. Waterstops – refer to Section 03-15-13 Waterstops for specification requirements.
- I. Anti-Graffiti Coating: The coating shall be Chemprobe Series 626 Dur A Pell GS (Graffiti Shield) by Chemprobe Coating Systems, LP. Where the Anti-Graffiti Coating is to be used over stone veneers or Structural Concrete Coatings, verify compatibility of the materials prior to application. A material safety data sheet (MSDS) and a complete set of manufacturer's mixing and application instructions shall be submitted to the Engineer before the Contractor begins applying the coating.

PART 3 EXECUTION

600.3.01 INSPECTION:

- A. General.
 - 1. Assure that excavations and formwork are completed. Refer to Concrete Forming - Section 618 for formwork requirements.
 - 2. Assure that dirt, mud, encrusted concrete, debris and excess water have been removed.
 - 3. Check that reinforcement is properly positioned and secured in place. Refer to Reinforcement – Section 619 for steel reinforcement requirements.
 - 4. Verify that expansion joint material, anchors, and other embedded items are secured in proper position.

600.3.02 PREPARATION:

- A. General.

1. Remove any hardened concrete and foreign material from inner surface of conveying equipment.
 2. Prepare slab subgrade in accordance with ACI 301.
 3. Designate limits of each placement and obtain Engineer's review of entire installation prior to proceeding.
 4. Subgrade for concrete flatwork (walks, trails, curb & gutter, etc.): Excavate to required depth, remove all soft, yielding material, replace with suitable on-site material. Place six-inch layer of approved free draining on-site material if determined to be necessary by the Engineer. Compact base to a firm, even surface. Compaction shall not be less than 95 percent dry density (ASTM D698).
- B. Concrete placed against gravel or crushed stone.
1. Prevent loss of water from concrete with a minimum 2 in. layer of material having 25 percent fines passing a No. 4 sieve.
- C. Concrete placed against rock.
1. Remove all loose pieces of rock.
 2. Clean exposed rock surface in accordance with Soils Engineers recommendations.
 3. Thoroughly wet hardened surface before placing fresh concrete.
- D. Concrete placed against hardened or existing concrete.
1. Prior to placing fresh concrete against surface of hardened concrete, complete the following:
 - a. Remove all laitance, foreign substances (including curing compound), wash with clean water, and thoroughly wet hardened surface before placing fresh concrete.
 - b. Apply epoxy-bonding agent at blockouts, cutouts and in locations directed by Engineer.

600.3.03 PLACEMENT:

- A. Conveying.
1. Convey concrete from mixer to final position as rapidly as practicable without segregation or loss of material.
 2. Use only metal or metal-lined chutes with maximum length of 20 ft, having a maximum slope of 1 vertical to 2 horizontal, and a minimum slope of 1 vertical to 3 horizontal.
 3. Provide a hopper at the end of long-belt conveyors and chutes not meeting the requirements in 2. above.
 4. Conveying by pumping methods shall conform to ACI 304, Chapter 9.
- B. Depositing in Walls.
1. Deposit concrete in a continuous operation until section is completed.

2. Concrete shall be deposited as nearly as practicable to its final position to avoid segregation due to rehandling or flowing.
3. Place concrete in approximately horizontal layers 2 ft maximum thickness.
4. Each layer of concrete shall be plastic when covered with following layer.
5. Rate of vertical rise not more than 2 ft per hour.
6. Provide placement capacity as necessary to comply with these requirements with construction and other joint locations shown on the Drawings.
7. Maximum height of concrete free fall, 4 ft.
8. Pump concrete or use a tremie having varying lengths for placing concrete in columns and walls to prevent free fall of more than 4 ft.
9. Concrete shall not be dropped through reinforcing steel nor subjected to any other procedure that will cause segregation.
10. Place and consolidate concrete in wall or column forms at least 24 hours prior to the time concrete or any reinforcing steel is placed in the system to be supported by such walls or columns except as noted below.
11. Do not exceed 6 ft of vertical height for any portion of a wall or column placed monolithically with floor or roof slab.
12. Allow concrete to thoroughly settle before top is finished. Remove all laitance, debris, and surplus water from surfaces at tops of forms by screeding, scraping, or other effective means.
13. Overfill forms wherever top of a wall will be exposed to weathering and after concrete has settled, screed off excess.
14. See Part 3.04 C. for preparation of construction joints prior to placing wall concrete.

C. Depositing in Floor and Roof Slabs.

1. Deposit concrete in a continuous operation until section is completed.
2. Concrete shall be deposited as nearly as practicable to its final position to avoid segregation due to rehandling or flowing.
3. Place concrete in strips approximately 10 ft wide approximately parallel to the wind direction at the time of placement. At least two placing crews shall be used, one working back and forth on each half of the slab, working the 10 ft wide strips continuously from one edge of the slab to the opposite edge.
4. Each strip of concrete shall be covered with 6 mil. thick plastic 12 ft. wide or Burlene, overlapped approximately 1.5 ft, prior to the development of plastic shrinkage cracks.

D. Depositing in Flatwork (Walks, Trails, Curb & Gutter, etc.).

1. Place concrete monolithically between expansion joints.
- E. Consolidation.
1. During and immediately after placement, thoroughly compact and work around all reinforcements, embedments, and into corners of forms, eliminating all air or stone pockets that may cause honeycombing, pitting, or planes of weakness.
 2. Use mechanical vibrators that will maintain at least 9,000 cycles per minute when immersed in concrete.
 3. Minimum horsepower per vibrator shall be 1-1/2.
 4. Number and type of vibrators shall be as acceptable to Engineer. A spare vibrator will be available at all times in case of mechanical problems.
 5. Over-vibrating and the use of vibrators to transport concrete laterally in forms will not be allowed.
 6. Vertically insert vibrators at points approximately 2 ft apart and to a depth to penetrate 6 in. into the preceding layer.
 7. Vibrate each location for a length of time to obtain adequate consolidation (generally 5 to 15 seconds).

600.3.04 JOINTS:

- A. Watertight joints (Waterstops).
1. Use at all locations where water is to be contained, groundwater is to be resisted and as shown on Drawings. Approved water stop is required at all such joints.
- B. Expansion and contraction (control) joints.
1. At locations shown on Drawings.
 2. Extend reinforcement continuously through joints, except "Expansion Joints," unless specifically shown on Drawings.
 3. Form joint with felt, ASTM D 2475, where "bond breaker" is indicated.
 4. Flexible joint filler material as indicated in Part 2.03, shall be used in Expansion Joints.
 5. Expansion and contraction joints shall be caulked with a joint sealer as indicated in Part 2.03.
- C. Construction joints.
1. Provide where shown on Drawings.
 2. Obtain Engineer's approval for proposed locations of construction joints not shown on Drawings or for proposed elimination of construction joints shown on Drawings.
 3. Locate joints to least impair the strength and serviceability of the structure, generally as follows:

- a. Columns and walls.
 - 1) At underside of beams, girders, haunches, drop panels, slabs, and at floor levels.
 - 2) All haunches and drop panels shall be considered as parts of supported floor or roof and shall be placed monolithically therewith.
 - b. Suspended slabs.
 - 1) At or near mid-span in flat slab construction.
 - c. Construction joints in walls, beams, girders, and slabs shall be perpendicular to planes of their surfaces, with expansive rubber waterstops, and shall not be keyed except as shown on Drawings.
 - d. Maximum length of wall segments without construction joints shall be 500 ft or as shown on the Drawings.
4. The surfaces of concrete to be cast against shall be thoroughly cleaned and all laitance removed. Concrete shall be vibrated adequately to prevent honeycombing at the joint.
 5. Construction joints shall require bond. After cleaning, before new concrete is placed, vertical joints shall be wetted unless otherwise detailed on Drawings or directed by Engineer. Prior to placement of concrete in walls, the bottom construction joint must be slushed with 2 to 3 in. of sand-cement grout. The sand-cement grout shall have a consistency similar to thick paint and shall be proportioned as specified in Part 2.03. The fresh concrete shall be placed before the grout has attained its initial set.
 6. Joints where indicated on Drawings or where directed by the Engineer to receive an epoxy bonding agent shall have been prepared and the bonding agent applied in accordance with the manufacturer's recommendations prior to placing fresh concrete.
- D. Joints for Concrete Flatwork (Walks, Trails, Curb and Gutter, etc.).
1. Construct all joints true to line with faces perpendicular to surface of the sidewalk, trail, etc. Maximum variance, ¼-inch from indicated position.
 2. Expansion Joints: Place joints every 100 feet, or at cold joints, or where directed by the Engineer. Set joint material full depth of slab, ¼-inch below the surface. Anchor in place. Finish joints with a ¼-inch radius edger.
 3. Control Joints: Place joints at the same interval as the width of the trail, but not more than 10 feet. Each joint will be struck perpendicular to the trail or where designated by the Engineer to a depth of ¼ of the thickness of the slab. Any joints not sufficiently deep will be saw cut to the required depth from the pavement surface. All joints shall be straight.
 4. Where a scoring pattern is indicated, accomplish by cutting ¼ the depth of concrete with a trowel or by placing metal strips and removing and finishing with a ¼-inch radius edger. Sawed joints of ⅓-inch width will be acceptable.
 5. Where existing or proposed structures, such as light standards, fire hydrants, and poles are within the limits of the sidewalk or flatwork area, score concrete in a block 8-inches wider than the maximum dimension of structure and place a ¼-inch premolded expansion joint around structure

600.3.05 FINISHING EXPOSED SURFACES:

- A. Finishing unformed surfaces.
 1. Slabs for aprons, slabs-on-grade, and tops of walls.

- a. Provide surface conforming to proper elevation and contour. Except as noted otherwise on the Drawings, all walks and slabs shall slope 2 percent away from buildings. All other walks, exterior concrete steps, etc. shall be pitched to drain out with a slope of ¼ in. per ft. Tops of retaining walls shall be pitched back (into the backfill) 0.25 in. per ft unless designated otherwise by the Engineer. All aggregates shall be completely embedded in mortar by screeding.
 - 1) Screeded surfaces shall be free of surface irregularities.
 - 2) Maximum variation from a plane surface in any 10 ft section shall be ¼ in.
2. Coordination of Finishing and Placement.
- a. Mixing and placing shall be carefully coordinated with finishing. Concrete shall not be placed on the subgrade or forms more rapidly than it can be spread, straight edged, and bull floated. These operations must be performed before bleeding water has an opportunity to collect on the surface.
 - b. To obtain good surfaces and avoid cold joints, the size of placing and finishing crews shall be planned with due regard for the effects of concrete temperature and atmospheric conditions on the rate of hardening of the concrete.
 - c. All flatwork finishers on the project shall be ACI Certified flatwork finishers or equivalent acceptable to the Engineer.
3. Jointing and Edging.
- a. Joints in slabs shall be located and detailed as indicated on the Drawings and in the Specifications.
 - b. Where saw-cut joints are required or permitted, cutting shall be timed properly with the set of the concrete. Cutting shall be started as soon as the concrete has hardened sufficiently to prevent aggregates from being dislodged by the saw. Cutting shall be completed before shrinkage stresses become sufficient to produce cracking. In all cases, the saw cutting shall be completed no later than within the first 12 hours after the slab finishing operations have been completed.
 - c. Edge exposed edges of floated or troweled surfaces with a tool having a ¼ in. corner radius, unless these edges are specified to be beveled.
4. Consolidation.
- a. Concrete in slabs shall be thoroughly consolidated. Internal vibration shall be used in beams and girders of framed slabs and along the bulkheads of slabs on grade. Consolidation of slabs shall be obtained with vibrating screeds, roller pipe screeds, internal vibrators, or other acceptable means. The concrete surfaces shall not be manipulated prior to finishing operations.
5. Finishes.
- a. Unless selection of finishes is made in the Specifications or on the Drawings, the following finishes shall be used, as applicable.
 - 1) Floated Finish - Use for tops of walls, footings, pile caps, etc.
 - 2) Troweled Finish - Use for floors in finished areas and where called for on Drawings.
 - 3) Broom Finish - Use for floor slabs, concrete stairs, landings, sidewalks, concrete trails, curb and gutters.
 - 4) Raked Finish - Use for slabs to receive topping or secondary concrete
 - 5) Light Sandblast – As indicated on Drawings and Specifications
 - 6) Medium Sandblast – As indicated on Drawings and Specifications
 - b. The following finishes shall be utilized on this project unless specified or detailed otherwise.
 - 1) Floated Finish.
 - a) After the concrete has been placed, consolidated, struck-off, and leveled by bull floating, the concrete shall not be worked further until ready for floating. Floating shall begin when the water sheen

has disappeared and/or when the mix has stiffened sufficiently to permit the proper operation of a power-driven float. The surface shall then be consolidated with power-driven floats of the impact type, except in thin sections, such as pan slabs, which shall be floated by hand. Hand floating with wood or cork-faced floats shall be used in locations inaccessible to the power-driven machine. Trueness of surface shall be rechecked at this stage with a 10-foot straightedge applied at not less than two different angles. All high spots shall be cut down and all low spots filled during this procedure to produce planes checking true under the straightedge in any direction, with tolerances not exceeding $\frac{1}{4}$ in. in 10 ft. The slab shall then be refloated immediately to a uniform, smooth, granular texture.

- 2) Troweled Finish.
 - a) Where a troweled finish is specified, the surface shall be finished first with impact power floats, as specified above where applicable, then with power trowels and finally with hand trowels. The first troweling after power floating shall be done by a power trowel and shall produce a smooth surface that is relatively free of defects, but which may still contain some trowel marks. Additional troweling shall be done by hand after the surface has hardened sufficiently. The final troweling shall be done when a ringing sound is produced as the trowel is moved over the surface. The surface shall be thoroughly consolidated by the hand troweling operations. The finished surface shall be free of any trowel marks and shall be uniform in texture and appearance, with tolerances not exceeding $\frac{1}{4}$ in. in 10 ft. On surfaces that support floor coverings, any defects of sufficient magnitude to show through the floor covering shall be removed by grinding.
- 3) Broom Finish.
 - a) Slabs shall be given a coarse transverse-scored texture by drawing a broom across the surface. This operation shall follow immediately after bull floating operations and hand floating as required to close the surface. Provide a uniform abrasive texture of constant color. On paths, walks and trails, broom at right angles to normal traffic direction.
- 4) Rake Finish.
 - a) Roughened concrete surface to a $\frac{1}{2}$ " minimum amplitude by raking.
- 5) Light Sandblast.
 - a) Light sandblast is defined as that which leaves an even fine-grained surface in which the cement mortar has been removed to the extent of starting to expose the small aggregate. Complete operations for a smooth form finish. If necessary, use grout rubbed finish to repair surface areas. Add color to grout mix to match color of concrete where colored concrete is specified. Contractor shall prepare a 3-foot square sample panel, including color additive, for review by the Engineer.
- 6) Medium Sandblast.
 - a) Medium sandblast is defined as that which leaves an even fine-grained surface in which cement mortar has been removed to the extent of exposing the small aggregate, and just starting to expose large aggregate. Complete operations for a smooth form finish. If necessary, use grout rubbed finish to repair surface areas. Add color to grout mix to match color of concrete where colored

concrete is specified. Contractor shall prepare a 3 foot square sample panel, including color additive, for review by the Engineer.

600.3.06 REPLACEMENT, REPAIRING AND PATCHING OF DEFECTIVE CONCRETE:

A. Removal and replacement of defective concrete:

1. After forms have been removed, any concrete that is not formed as shown on the Drawings, is out of alignment or level beyond the required tolerance, shows a defective surface that cannot be properly repaired or patched, or cannot be shown to prevent water migration through concrete surfaces or joints, shall be removed and replaced at the Contractor's expense.
2. Liquid retaining concrete walls, slabs, beams, etc., cannot have any honeycombing, cold joints, cracks greater than 0.004 in. wide, or leakage of water through the concrete thickness or joints. If in the opinion of the Engineer the honeycombing, cold joints, cracks or leakage are excessive, the Contractor shall be required to remove the complete concrete segment and replace it. Where minor honeycombing, cold joints, cracks or leakage occurs, it shall be repaired as indicated in Part 3.07.B and C below.

B. Repair of tie holes, blockouts, cutouts and defective concrete.

1. Immediately after form removal, repair, to the satisfaction of the Engineer, all repairable surface defects, including tie holes, in concrete surfaces. In all cases, repair work shall be completed within 24 hours of removal of the forms and prior to application of curing compound.
2. Replace, to satisfaction of Engineer, within 48 hours after adjacent forms have been removed, all other honeycombed and defective concrete areas that cannot be immediately repaired as noted in item 1 above.
3. Cut out and remove to sound concrete, with edges square-cut to avoid feathering, all honeycombed or otherwise defective concrete.
4. Repair work shall conform to ACI 301 and these specifications. At all blockouts, tie-holes and cutouts, after being thoroughly cleaned, apply an epoxy-bonding agent and fill with non-shrink grout, as specified in the materials section of this specification. Color shall be added to match surrounding concrete.
5. Perform in a manner that will not interfere with thorough curing of surrounding concrete.
6. Adequately cure all repair work.

C. Repair of cracks and minor honeycombed areas.

All cracks, minor honeycombed concrete or other areas of apparent leakage, including wet spots on walls, shall be sealed with Epoxy Sealant injection or other acceptable means so that the concrete is watertight.

600.3.07 FINISHING FORMED SURFACES:

A. Finishing.

1. Rough form finish - All surfaces not exposed to view such as surfaces in contact with earth.
 - a. Chip off all fins and other surface projections greater than ¼ in. high.

- b. Fill all tie holes and repair and patch all defects.
2. Smooth form finish - All exposed surfaces not generally exposed to view including interior surfaces of structures.
 - a. Use form facing to produce a smooth, hard uniform surface.
 - b. Keep number of seams to a minimum.
 - c. Remove all fins and projections.
 - d. Clean, coat, and fill all tie holes.
 - e. Repair and patch all defects.
 3. Grout-Rubbed Finish – Provide a grout-rubbed finish on all concrete surfaces exposed to view. Do not begin cleaning surface until all contiguous surfaces are completed and accessible and can be completed at the same time.
 - a. Complete operation for smooth form finish (see above), then wet surface and apply grout mix of 1 part of Portland Cement and 1-1/2 parts of fine sand by volume with sufficient water to produce a grout having the consistency of thick paint. Substitute white Portland Cement for a part of the gray as required in order to produce a color matching the color of the surrounding concrete, as determined by a trial patch. Wet the surface of the concrete sufficiently to prevent absorption of water from the grout and apply the grout uniformly with brushes or a spray gun.
 - b. Immediately after applying the grout, scrub the surface vigorously with a cork float or stone to coat the surface and fill all air bubbles and holes.
 - c. While the grout is still plastic, remove all excess grout by working (rubbing) the surface with a rubber float, burlap, or other means.
 - d. After the surface whitens from drying (about thirty minutes at normal temperatures), rub vigorously with clean burlap.
 - e. The finish shall be kept damp for at least 36 hours after final rubbing.
 - f. Proper curing temperatures need to be maintained just as with other concrete work.
 4. Sandblast finish – Exposed surfaces exposed to view, where indicated on the Drawings to be sandblasted, shall include requirements of a smooth form finish followed by sandblasting to remove approximately 1/8-inch of surface concrete.
 5. Anti-Graffiti Coating - All surfaces where noted on the Drawings, in the Specifications and/or in the Contract to receive an Anti-Graffiti Coating.
 - a. Where an Anti-Graffiti Coating is called out on the Drawings, in the Specifications and/or in the Contract, the coating shall be applied to all exposed surfaces of the structure above the ground line, including all walls and headwalls, and shall also extend 6 inches below the finished ground line. This will require staged backfilling of the front face of the wall.
 - b. Sidewalks, paths, concrete wall surfaces, wall caps, bridge bearing= devices, curb and barrier cover plates, steel fence, and steel rail shall be masked or otherwise protected to prevent Anti-Graffiti Coating from coming into contact with them.
 - c. The final color of the Anti-Graffiti Coating shall be clear.
 - d. The Anti-Graffiti Coating shall be applied in accordance with the manufacturer's instructions and recommendations.
 - e. New mortar joints of any stonework shall be at least 28 days old, or as otherwise approved in writing by the Coating manufacturer, before the coating is applied.

600.3.08 CURING:

A. General.

1. Freshly deposited concrete shall be protected from premature drying and excessively hot or cold temperatures and shall be maintained without drying at a relatively constant temperature for the period of time necessary for the hydration of the cementitious materials

and proper hardening of the concrete. A list of all intended curing methods including a description of materials shall be submitted to the Engineer for review.

2. Initially, the concrete temperature shall be maintained at or above 70° F. for 3 days or at or above 50° F. for 5 days. Continue curing as required to achieve the specified 28-day strength. See Part 1.05 Job Conditions for additional information.
3. Keep concrete continuously moist for at least 7 days after placement by use of:
 - a. Ponding or continuous sprinkling.
 - 1) Begin as quickly as possible after initial set.
 - 2) Provide complete coverage with minimum of runoff by regulating rate of water application.
 - 3) Interrupt application of water to walls for finishing or repair work only over areas being finished.
 - 4) Do not permit wall areas to become dry that are not being finished.
 - 5) Resume curing immediately after each day's finishing operations.
 - b. Polyethylene film see Item C. below.
 - c. Wet burlap, wet absorptive mats, or wet sand.
 - d. Leave forms in place for concrete walls and keep wet.
4. Use membrane-curing compound as noted below.

B. Membrane curing compound (conforming to ASTM C 309).

1. Shall be used prior to placement of plastic sheeting on concrete floor and roof slabs, walls and other miscellaneous concrete areas where acceptable to Engineer.
2. Spray-apply in 2 coats perpendicular to each other at coverage recommended by manufacturer. Use clear membrane curing compound, not white, on flatwork (walks, trails, paths, etc.).
3. Cover unformed surfaces with curing compound within 30 minutes after final finishing.
4. Apply curing compound immediately to formed surfaces if forms are removed before end of specified curing period. Curing compound sprayed in tie holes is to be cleaned out before patching tie holes. Forms may be left in place for all or part of the curing period; wood forms shall be kept wet.
5. Protect compound against abrasion during curing period.

C. Film Curing (conforming to ASTM C 171).

1. Film curing shall not be used in lieu of water curing on tank floor and roof slabs. Use only where specifically reviewed and acceptable to Engineer.
2. Concrete placed early in the concrete placing operation shall not be allowed to dry out. Apply Membrane Curing Compound, or other material acceptable to the Engineer, as noted above prior to placing the polyethylene film or other coverings.
3. Begin as quickly as possible after initial set of concrete.
4. Cover surfaces completely with polyethylene sheeting.
5. Overlap edges for proper sealing and anchorage.

6. Cover joints between sheets with dunnage as required to prevent displacement due to wind or other factors.
7. Promptly repair all tears, holes, and other damage.
8. Anchor continuously all edges and anchor surface as necessary to prevent billowing.

600.3.09 QUALITY CONTROL:

A. Concrete tests.

1. Shall be paid for by the Contractor, except where noted otherwise in these specifications, and shall be in accordance with the requirements of ACI 301, except as noted or modified in this Section. Test specimens shall be taken by an ACI Certified Concrete Field-Testing Technician - Grade 1 in accordance with the "Standard Method of Making and Curing Concrete Test Specimens in the Field," ASTM C 31.
 - a. Strength test.
 - 1) Mold and laboratory cure five cylinders from each sample.
 - 2) Test two cylinders at 14 days per ASTM C 39. Test two cylinders at 28 days for acceptance. Keep the remaining one as a spare to be tested as directed by Engineer.
 - 3) The spare cylinder for each sample may be eliminated after the first several concrete placements of each type of concrete if, in the opinion of the Engineer, test results are consistent and within specifications.
 - b. Minimum samples.
Collect the following minimum samples for each 28-day strength concrete used in the work for each day's placing:

<u>Concrete Quantity</u>	<u>Number of Samples</u>
50 yds ³ or less	one
50 to 100 yds ³	two
100 yds ³ or more	two plus one sample for each additional 100 yds ³
 - c. Slump test.
 - 1) Conduct test for each strength test sample and whenever consistency of concrete appears to vary.
 - 2) Slump tests shall be made using "Method of Test for Slump of Portland Cement Concrete" (ASTM C 143).
 - d. Air content.
 - 1) Conduct test from one of first three batches mixed each day and for each strength test sample.
 - 2) Samples indicating low air contents by the pressure method air content tests in accordance with ASTM C 231 shall be verified by the gravimetric method, ASTM C 138, and the volumetric method, ASTM C 173, before adding additional air entraining admixture in the field.
2. The Contractor shall provide the following to the Owner and the Testing Agency at no additional cost to the Owner:
 - a. Incidental labor required to facilitate testing.
 - b. Minimum one day's advance notice when concrete is to be placed.
 - c. Storage facilities for concrete test cylinders; including, when necessary, a specially prepared box with high-low thermometer and thermostatically controlled heating devices in accordance with Section 9.2 of ASTM C 31 for storage of the cylinders for the first 24 hours after molding.
 - d. Materials, samples, and access to materials as required for testing.

- e. Reimbursement of costs for testing and inspection resulting as a consequence of the following:
 - 1) Work not in compliance with the Contract Documents.
 - 2) Testing requested by the Contractor or Subcontractor such as field-cured cylinder tests for stripping strengths, etc.
 - 3) Testing to verify the adequacy of work done, without prior notice, without proper supervision, or contrary to standard construction practice.
- f. The use of testing services shall in no way relieve the Contractor of his responsibility to furnish materials and construction in full compliance with the Drawings and Specifications.

B. Acceptance of Concrete.

- 1. If the early strength tests fall below the early strengths deemed necessary to achieve the specified 28-day strength, the Engineer shall have the right to require conditions of temperature and moisture necessary to secure the required strength. The Engineer may also require pull out tests in accordance with ASTM C 900 or core tests in accordance with ASTM C 42.
- 2. Strength level of concrete will be considered satisfactory so long as average of all sets of two consecutive strength test results equals or exceeds specified 28-day strength and no individual strength test result falls below the specified strength by more than 500 psi.

C. Failure of Test Cylinder Results.

- 1. Upon failure of the 28-day test cylinder results, Engineer may require Contractor at his expense, to obtain and test at least three pullout tests or 2-in. diameter cored samples from area in question.
- 2. Concrete will be considered adequate if average of three pullout or core tests is at least 85 percent of, and if no single core is less than 75 percent of the specified 28-day strength.
- 3. Upon failure of the pullout or core test results, Engineer may require Contractor, at his expense, to perform load tests as specified in ACI 318, Chapter 20, or remove and replace as directed by the engineer.
- 4. In the event an area is found to be structurally unsound, the Engineer may order removal and replacement of concrete as required. The cost of the pullout or core tests, and the load test and the structural evaluation shall be borne by the Contractor.
- 5. Fill all pullout or core holes as specified for repairing defective concrete.

- END OF SECTION -

ADDITION OF SECTION 617 – STEEL SHEET PILE

Section 517 is hereby added to the Standard Specifications and shall include the following:

617.01 GENERAL
617.01.01 DESCRIPTION

- A. This section covers all members to be used in the construction of steel sheet pile. This Specifications also covers the installation of steel sheet piling and trimming of the sheet pile to the

lines and grades shown on the Drawings or as required. This work also includes pre-drilling to facilitate driving sheet pile to install sheet pile to the designated elevations.

617.01.02 QUALITY STANDARDS:

American Society of Testing Materials
ASTM – A328, (Grade 50) – Sheet Piling
ASTM – A328 or A690 – Steel corners, tees, wyes, and crossings

617.01.03 SUBMITTALS: Contractor shall provide information from the manufacturer that indicates the sheet piling meets or exceeds the Specification listed in this Section.

617.02 PRODUCTS

617.02.01 SHAPES:

- A. Steel sheet piles and special fabricated shapes shall be of a design that assures continuous interlock throughout the entire length when in place.
- B. Additional length beyond those indicated on the Drawings may be required to provide for trimming of tops of sheet piling.
- C. Steel sheet piles and interlocks shall not have excessive kinks, camber or twist that would prevent the pile from reasonably free sliding to grade.

617.02.01 MATERIALS:

- A. Sheet Pile: PZ 22 sheet pile shall be installed according to the plans.
- B. The interlocks between steel sheet pile sections shall be configured such that the average width of the annular space between all contact points of the interlocks shall be a maximum of 1/8 inch, as determined by the Engineer.
- C. Steel sheet piling shall meet the requirements of ASTM A328, (Grade 50). Steel corners, tees, wyes, and crosses shall meet the requirements of ASTM A328 or A690.
- D. All steel sheet piling shall be new and un-spliced material throughout unless otherwise reviewed and accepted by the Engineer.
- E. Handling holes: If handling holes are provided, they shall be two standard 2-9/16-inch diameter handling holes located 6 inches from one end. If not encapsulated by sheet pile cap concrete, the holes shall be plugged by welding a piece of steel over the hole prior to installing any riprap, backfill or drop structure cap. The plated hole shall be watertight.
- F. All fabricated connections shall be made with the use of angles or bent plates, as necessary, and shall be adequately welded or connected with high strength bolts as accepted by the Engineer.
- G. Sheet Pile Cap: Shall be 12-inches by 12-inches by 1/2-inch thick ASTM A36 Steel with a continuous weld on both sides to the top of sheet pile with a spacing of no more than 48-inches on-center, unless shown otherwise on the Drawings.

617.03 EXECUTION

617.03.01 CONSTRUCTION REQUIREMENTS:

- A. Sheet piling installer must have, as a minimum, three successful past installations of sheet piling of comparable overall heights and sections and comparable penetration into soils similar to those found on the Project.
- B. Do not begin sheet pile installation until the earthwork in the area where the piles are to be driven has been completed to the extent that the grade elevation is at no more than 12 inches above or below the top of the piling elevation as indicated on the Drawings.
- C. Steel sheet piling shall be assembled before driving and then driven as a continuous wall, progressively in stages to keep the piles aligned correctly and minimize the danger of breaking the interlock between the sheets. The piling shall be driven within the following tolerances:
 - Alignment - sheet pile shall be driven to form a relatively straight line between the termini points shown on the Drawings. Horizontal deviation of any point from a straight line connecting the two ends of the wall section shall be a maximum of 6 inches.
 - Plumbness - each individual sheet pile section shall be driven vertical, within a horizontal tolerance of 2 percent of any vertical length measured along the pile.
 - Elevation - tops of sheet pile sections shall be within a tolerance of 1 inch from plan elevations. Contractor shall not be paid for excess sheet pile trimmed off the end of the pile to meet final grade.
- D. Steel Z piling shall be driven with the ball-end leading. Proper care and planning shall be used to allow for this construction procedure in both immediate and possible future walls.
- E. Alternate Z piles must be reversed end for end for proper interlocking in the "normal" position. Piles shall also be aligned properly to maintain a "normal" driving width.
- F. For sheet piles driven into the native soils, pre-drilled soils, or excavated soils, a vibratory driver may be used as long as the required depth is obtained. For sheet piles being driven into bedrock, an approved hammer utilizing a minimum hammer energy of 19,000 foot-pounds per square inch of steel section shall be used to obtain the required depth or virtual refusal. The Contractor shall submit verification from the manufacturer that the hammer can deliver the required energy. The hammer shall be clearly marked so that it can be identified at the job site.
- G. Steel sheet piling shall be driven to the depths shown on the Drawings or to virtual refusal. Virtual refusal is defined as 10 blows per inch with an approved pile hammer. A pile hammer shall be used to determine virtual refusal. The hammer shall be operating at the manufacturer's recommended stroke and speed when virtual refusal is measured.
- H. Care shall be taken during driving to keep from causing deformations of the top of the piles, splitting of section, or breaking of the interlock between sections. Care shall also be taken during driving to prevent and correct any tendency of steel sheet piles to twist or get out of plumb. Steel sheet piling shall be driven to form a tight bulkhead. A driving head shall be used and any piling which is damaged in driving or which has broken interlocks between sections shall be pulled and replaced at Contractor's expense.
- I. Steel sheet pile that is full length as shown on the Drawings and is required to be driven below the specified cutoff elevation shall be spliced with additional steel sheet piling with a full penetration butt weld. Splice locations, if necessary, must be reviewed and accepted by the Engineer prior to installation.

- J. Contractor shall brace and/or provide soil grading as necessary during construction operations in order to provide lateral stability for the sheet pile wall. The sheet pile wall has been designed for the soils grades of the final configuration denoted on the Drawings only. Other temporary configurations during the construction period shall not be allowed.

In lieu of driving the sheet pile, the Contractor may (at his option) excavate to elevations shown on the Drawings and place sheet pile. Backfill of sheet pile shall be per Sections 621 – Channel Excavation and 622 – Channel Embankment and Backfill. A combination of excavation and driving of sheet pile will also be acceptable.

- K. All welding or gas cutting shall be in accordance with the current standards of the American Welding Society.
- L. Reinforcing bars shall be welded to the sheet pile at locations shown on the Drawings.

-END OF SECTION-

ADDITION OF SECTION 618 – CONCRETE FORMING

618.01 GENERAL

618.01.01 DESCRIPTION:

This section covers furnishing, erecting and removing forms for cast-in-place concrete.

618.01.02 QUALITY ASSURANCE:

A. Reference Standards:

1. American Concrete Institute Standards (ACI)
 - a. 301 Specifications for Concrete Construction
 - b. 347 Guide to Formwork
 - c. As modified herein.

B. Design Criteria:

1. The Contractor shall design the formwork for the loads, lateral pressures and allowable stresses outlined in Chapter 1 of ACI 347.

C. Maximum Allowable Tolerances:

1. Variation from Plumb
 - a. Lines and surfaces of columns, piers and walls
 - 1) In any 10 feet of length 1/4 inch
 - 2) Entire length 1 inch
 - b. Control-joint grooves, and other conspicuous lines
 - 1) In any 20 feet of length 1/4 inch
 - 2) In 40 feet or more 3/4 inch
2. Variation from level or specified grade
 - a. Slabs, beams and roof
 - 1) In any 10 feet of length 1/4 inch
 - 2) In any 20 feet of length 3/8 inch
 - 3) Entire length 3/4 inch

3. The maximum deflection of facing materials reflected in concrete surfaces exposed to view shall be 1/240 of the span between supporting members.
4. Refer to ACI 301 for additional requirements.

D. Architectural Requirements:

1. submit details of the forming system to be used for the walls including details of formwork, form liner, form ties, thru bolts, rustications, finishing techniques and other items used in the construction of the wall. An elevation of the wall showing the layout of the formwork, form liner, form ties, chamfers, and other formwork details shall be submitted. An aesthetically pleasing layout and finished surface for the wall shall be provided.
2. Prior to construction the Contractor shall construct a sample panel of the proposed construction for the Engineer's approval. The panel shall be approximately 6 ft long by 4 ft high and of the same construction as the proposed wall. The sample panel shall show the workmanship, form liner, joints, form ties, color and texture to be used for the wall. The accepted panel shall form the standard for accepted finished work on the project.

618.01.03 SUBMITTALS: Submit certificate stating form materials to be used. All submittals shall be made in accordance with Project Special Provisions Section 2.22

618.02 PRODUCTS

618.02.01 FORM MATERIALS:

- A. General: Where "Smooth Form Finish," or "Grout Cleaned Finish" is specified, use prefabricated plywood panel forms, job-built plywood forms, forms lined with plywood or fiberboard, or steel forms. Where "Rough Form Finish" is specified, unlined wooden forms may be used.
- B. Form liner shall be as indicated on the Landscape Architect Drawings. Concrete placed in sections with a form liner shall be placed and consolidated as recommended by the form liner manufacturer and ACI Specifications. All formwork shall be approved by the Landscape Architect.
- C. Steel Forms: Symons "Steel-Ply," Simplex "Industrial Steel FrameForms," Universal "Uniform" or equivalent.
- D. Plywood Forms: Product Standard PS-1, - waterproof, resin-bonded exterior type Douglas fir.
- E. Fiberboard Forms: Federal Spec LLL-B-810 - Type II tempered, waterproof, screenback, concrete form hardboard.
- F. Lumber (Including Board and Batten Forms): Straight, uniform width and thickness, free from knots, offsets, holes, dents, and other surface defects. Lumber must be sufficiently sealed to prevent the absorption of water, form release agent, etc.
- G. Chamfer strips: Clear white pine, surface against concrete planed.
- H. Form ties:
 1. Removable end, permanently embedded body type with waterstop.
 2. Sufficient strength and rigidity to support and maintain the form in proper position and alignment without the use of auxiliary spreaders.

3. When cones are provided on the outer ends the permanently embedded portion shall be back a minimum of one inch from concrete surface.
 4. Permanently embedded type without threaded ends shall be so constructed so that removable ends are readily broken off (one inch back from concrete surface) without damage to the concrete.
 5. Form ties in exposed surfaces shall be uniformly spaced and aligned in horizontal and vertical rows. Form ties and their layout shall be approved by the Landscape Architect. Submit details of ties and proposed pattern for review.
- I. Joints: Joints shall be flat, not keyed, with adhesive waterstops, unless otherwise shown on Drawings.
- J. Polyethylene Film: Product Standard PS17; 6 mil.
- K. Form Coating:
1. Non-staining chemical release agent that will not damage the concrete surfaces and appropriate for use in potable water structures.
 2. For all exposed surfaces not in contact with earth backfill use Symons Corp. "Magic Kote", L & M "Debond" or equivalent.
 3. The concrete will have a curing compound and stain finish applied to it. Form coating shall be compatible with these products or shall be removed in such manner that it doesn't effect the application of these products.

617.03 EXECUTION

617.03.01 ERECTION:

- A. General:
1. Erect forms substantially and sufficiently tight to prevent leakage of mortar and braced or tied to maintain the desired position, shape and alignment before, during and after concrete placement. At vertical wall joints where forms overlay existing concrete, a mortar tight joint shall be required. Use a bead of silicone caulking or foam joint filler against concrete before placing form. Alternate methods shall be acceptable to the Engineer.
 2. Use adequate walers, stiffeners and braces to ensure proper alignment and stability until the wall construction is completed.
 3. Provide temporary openings at the bottom of column and wall forms and at other locations where necessary to facilitate cleaning and inspection.
 4. Temporary openings in wall or column forms used to limit the free fall of concrete to a maximum of 4 feet shall be located to facilitate placing and consolidation of the concrete. Such openings in walls shall not exceed 8 feet laterally to avoid moving concrete laterally more than 4 feet.
 5. If tremies of proper length are used for depositing concrete in walls or columns, temporary openings for concrete placement will not be required.

6. Whenever the top of a wall will be exposed to weathering, do not extend the forms on one side above the top of the wall; bring to true line and grade.
7. At other locations, bring forms to a true line and grade, or provide a wooden guide strip at the proper location on the forms so that the top surface can be finished with a screed or template for concrete which is to have a specified elevation, slope or contour.
8. At horizontal construction joints in walls, do not extend the forms on one side more than 2 feet above the joint. Horizontal construction joints shall not be used in walls of water retaining structures or exposed walls, unless reviewed and accepted by the Engineer.
9. Where concrete is placed against rock, remove all loose pieces of rock and clean the exposed surface with a high pressure hose.

B. Embedded Items:

1. Anchor bolts, castings, steel shapes, conduits, sleeves, waterstops, masonry anchorage and other materials that are to be embedded in the concrete shall be accurately positioned in the forms and securely anchored.
2. Install conduits in walls or slabs with reinforcement in both faces between the two faces of reinforcing steel.
3. In walls or slabs which have only a single mat of reinforcing steel, place conduits near the center of the wall or slab.
4. Unless installed in pipe sleeves, provide anchor bolts with sufficient threads to permit a nut to be installed on the concrete side of the form or template.
5. Install a second nut on the other side of the form or template and adjust the two nuts so the bolt will be held rigidly in proper position.
6. Assure embedments are clean when installed.
7. After concrete placement, clean surfaces not in contact with concrete or concrete mortar and other foreign substances.

C. Preparation of Form Surfaces:

1. Remove mortar, grout, and other foreign material from form surfaces.
2. Coat form surfaces with form coating material before either the reinforcing steel or concrete is placed. Ensure that dimension lumber board and batten forms are properly sealed so that they do not absorb form coating or water.
3. Do not allow form coating to:
 - a. Stand in puddles in the forms.
 - b. Come in contact with the reinforcing steel.
 - c. Come in contact with adjacent hardened concrete against which fresh concrete is to be placed.

D. Edges and Corners:

1. Place chamfer strips in forms to bevel exposed edges and projecting corners. Tool the top edges of walls and slabs not indicated on the Drawings to be beveled.

2. Form beveled edges for all vertical and horizontal corners of equipment bases unless indicated otherwise on the Drawings.
3. Chamfer strip shall be 3/4 inch unless indicated otherwise on the Drawings.

E. Removal:

1. Do not remove or disturb forms until the concrete has attained sufficient strength to safely support all dead and live loads.
2. For beams, slabs and similar sections the shores and supports shall remain in place until the concrete has reached its specified 28-day strength, unless otherwise specified or permitted by the Engineer. Determine strength from pullout tests in accordance with ASTM C 900 or job cured cylinder breaks. Cylinders shall be job cured in same manner as the formed concrete.
3. Retain shoring in place and reinforce as necessary to carry out construction equipment, materials or other loads in excess of cured strength. Brace walls and columns after removal of forms to resist wind and construction loads.
4. Use care in form removal to avoid surface gouging, corner, or edge breakage, and other damage to the concrete.
5. Do not commence form removal for concrete not yet supporting loads, earlier than the following schedule, unless field cured cylinders and/or maturity meters indicate the concrete has reached 85 percent of the specified 28-day strength:

a.	Walls and columns	24 hours
b.	Vertical sides of beams and girders	24 hours
c.	Bottom forms and shoring for non-pre-stressed slabs, beams and girders under 10 feet clear span between permanent supports.	7 days
d.	Bottom forms and shoring for non-pre-stressed slabs, beams and girders between 10 and 20 feet clear span between permanent supports.	14 days
e.	Bottom forms and shoring for on prestressed slabs, beams and girders over 20 feet clear span between permanent supports.	21 days
f.	Refer to ACI 347, Chapter 2, for additional requirements.	

- END OF SECTION -

ADDITION OF SECTION 619 – REINFORCEMENT

619.01 GENERAL

619.01.01 DESCRIPTION: This section covers furnishing and installing steel bars and welded wire fabric for concrete reinforcement.

619.01.02 QUALITY ASSURANCE:

A. Reference Standards:

1. American Concrete Institute Standards (ACI)
 - a. 301 Specifications for Concrete Construction.
 - b. 315 Manual of Standard Practice for Detailing Reinforced Concrete Structures.
 - c. 318 Code Requirements for Structural Concrete
 - d. 350 Code Requirements for Environmental Engineering Concrete Structures.
2. As modified herein or on the Drawings.

B. Allowable Tolerances:

1. Fabrication Tolerances
 - a. Sheared length: ± 1 inch
 - b. Depth of truss: $+0$, $-1/4$ inch for concrete thickness 24 inches or less and $+0$, $-1/2$ inch for concrete thickness over 24 inches.
 - c. Overall dimensions of stirrups, ties and spirals: $+0$, $-1/4$ inch for concrete thickness 24 inches or less and $+0$, $-1/2$ inch for concrete thickness over 24 inches.
 - d. All other bends ± 1 inch.
2. Placement Tolerances

See Section 619.03.02.C

619.01.03 SUBMITTALS: All submittals shall be made in accordance with Project Special Provisions Section 2.22.

A. Shop Drawings:

1. Before fabrication of reinforcing steel, the Contractor shall review and approve shop drawings, bar lists, fabrication and setting drawings and shall submit the same to Engineer for review.
2. Show sizes, quantity and dimensions for fabrication and placing of reinforcing bars and bar supports. Indicate bar schedules, stirrup spacing, and diagrams of bent bars.

B. Certificates: Mill test certificates identifying chemical and physical analysis of each load of reinforcing steel delivered.

C. Manufacturer's Literature: Manufacturer's specifications and installation instructions for splice devices when these devices are called for on the Drawings.

619.01.04 PRODUCT DELIVERY, STORAGE AND HANDLING:

- A. Deliver to site in bundles marked with metal tags indicating bar size and length.
- B. Carefully handle and store on supports that will keep the steel from coming in contact with the ground or standing water.

619.02 PRODUCTS

619.02.01 REINFORCEMENT BARS:

- A. Bars: Steel reinforcement bars shall be new, deformed billet steel, meeting ASTM A 615; Grade 60. Weldable reinforcement bars shall conform to ASTM A 706, Grade 60.
- B. Epoxy Coated Bars: Epoxy coated steel reinforcing bars shall be new, deformed billet steel, meeting ASTM A 775/A 775M; Grade 60. Coatings shall be applied in plants that are certified in accordance with Concrete Reinforcing Steel Institute (CRSI) Epoxy Coating Plant Certification Program or equivalent. Damage to coating due to shipment, storage and handling shall be repaired in accordance with manufacture's written recommendations.
- C. Tie Wire: Annealed steel, Fed. Spec. QQ-W-461, 16 gauge minimum, epoxy coated.
- D. Fabrication: In accordance with CRSI Manual of Standard Practice except for the allowable tolerances specified herein in 619.01.02B.

619.02.02 BAR SUPPORTS:

- A. Conform to "Bar Support Specifications," CRSI Manual of Standard Practice.
- B. The portions of the supports or accessories within ½ inch of the concrete surface shall be coated with plastic at least 3/32-inch thick at points of contact with the formwork. Other requirements shall be in accordance with Class 1, maximum protection, plastic protected bar supports, in Chapter 3 of the Manual of Standard Practice by CRSI.

619.02.03 **WELDED WIRE REINFORCEMENT:** Welded Wire Reinforcement shall be electrically welded wire fabric of cold-drawn wire (70,000 psi yield point) of gauge and mesh size shown on the drawings and shall conform to "Specification for Welded Steel Wire Reinforcement for Concrete Reinforcement" (ASTM A 1064).

619.02.04 **BAR COUPLERS:** Reinforcing steel bar splicing couplers shall be a mechanical type as manufactured by BarSplice Products Inc., or equal. Couplers shall develop 125% of the specified yield strength of the reinforcing bars. Make field demonstrations and sample splicing prior to splicing bars being included into the work.

619.03 EXECUTION

619.03.01 PREPARATION:

- A. Remove all mud, oil, loose rust or mill scale or other foreign materials on reinforcing bars that may reduce bond prior to pouring concrete.
- B. Rust or mill scale that is "tight" will be permissible without cleaning or brushing provided weights, dimensions, cross-sectional area, and tensile properties meet requirements of ASTM A 615.

619.03.02 INSTALLATION:

- A. Bar Placement:
 - 1. Conform to CRSI-WCRSI "Placing Reinforcing Steel."

2. Reinforcement shall be supported and wired together to prevent displacement by construction loads or the placing of concrete.

B. Bar Supports:

1. Provide at least the number of supports as required by ACI 315.
2. All reinforcement shall be tied to chairs to secure them from displacement during concrete placement. Reinforcement shall be secured at a maximum distance of four feet on center. All chairs shall be stapled to wooden soffits. Staples and tie wire only shall be used to secure chairs to forms, except as reviewed by the Engineer.
3. Do not use pebbles, pieces of broken stone, common or face brick, metal pipe or wood blocks to support reinforcement.

C. Placement Tolerances:

1. Clear distance to formed surface: See 619.03.02 D.1 and 619.03.02 D.2.
2. Minimum spacing between bars: -1/4 inch
3. Top bars in slabs and beams: See 619.03.02 D.1 and 619.03.02.D.2.
4. Spacing crosswise of members: Spaced evenly within 2 inches.
5. Lengthwise of members: \pm 2 inches.
6. Maximum bar movement to avoid interference with other reinforcing steel, conduits or embedded items: one bar diameter. If bars are moved more than one bar diameter, or enough to exceed the above tolerances, the resulting arrangement of bars may be rejected by the Engineer.

D. Concrete Cover:

1. Except as otherwise indicated on the Drawings, provide the following minimum concrete cover for reinforcement.
 - a. Unformed surfaces adjacent to excavation
Non-prestressed Concrete 2 inches
 - b. Formed or top surfaces exposed to weather or saturated air, submerged or in contact with earth.
Non-prestressed Concrete 2 inches
 - c. Other locations:
Bars in beams or columns, including stirrups & ties: 2 inches
 - d. Placed against earth 3 inches
2. Cover for reinforcing steel shall not be less than the minimum given above (no minus tolerance) and shall not exceed the minimum by more than 1/4 inch where concrete thickness is 24 inches or less, or more than 1/2 inch where the concrete thickness is more than 24 inches.

E. Reinforcement Adjustment:

1. Move reinforcing bars only as stated under 3-2 C 6.
2. Do not heat, bend or cut bars without Engineer's approval.
3. Grade 60 bars shall not be bent after being partially embedded in hardened concrete unless approved by engineer.

F. Splices:

1. Do not splice bars except at locations shown on the Drawings without the Engineer's approval.
2. Minimum lap distance shall be as shown on the Drawings. If not shown, splices shall be Class B tension lap splice as specified in ACI 318.
2. Tie splices securely to prevent displacement by construction loads or during placement of concrete.
3. Splices in wall reinforcement and slabs shall be staggered such that no more than one bar in two is spliced in any four-foot-wide vertical section.
4. Reinforcement shall be continuous around corners or corner bars provided.

G. Welded Wire Reinforcement:

1. Install in longest practicable length.
2. Lap adjoining pieces 2 meshes plus end extension of wires, but not less than 12 inches in structural slabs.
3. Do not locate laps midway between, or directly over, support members of continuous structures.
4. Offset laps in adjacent widths to prevent continuous laps.
5. Extend reinforcement through contraction joints and construction joints unless otherwise indicated on the Drawings.

- END OF SECTION -

REVISION OF SECTION 620 DRAINAGE CHANNELS

Section 620 of the Standard Specifications is hereby revised as follows:

Under Subsection 621.01, add the following:

CONTRACTOR to review and familiarize themselves with the project Geotechnical Evaluation Report prepared by Vivid Engineering Group, included with the bid package.

Revise Subsection 621.04 to delete the words “at no additional cost to the owner” and replace with “all of the costs for dewatering shall be included in the Lump Sum bid price for Water Control and Dewatering”.

Under Subsection 621.05 Modify the Following:

In Paragraph B modify the compaction standard for cohesionless soils to be 95% maximum Modified Proctor dry density (ASTM 1557) at +/-2% optimum moisture content.

Add Subsection 621.055 “**Muck Excavation and Replacement**”

Where excavation to the finished grade or subgrade results in a subgrade consisting of unsuitable saturated soil, the **Engineer** may require the **Contractor** to remove and replace the unsuitable material with approved material compacted in a maximum of 8-inch loose lifts to a minimum of 95% maximum dry density Modified Proctor (ASTM 1557) at +/- 2% optimum moisture content to re-establish the finished grade or sub-grade. Unstable material shall be removed from the project site and disposed of by the **Contractor**. Muck Excavation and Replacement will not be paid for separately but will be considered incidental to the bid item that it is associated with.

Add Subsection 621.056 “**Cattail Over-Excavation**”

Harvest and stockpile 1-foot depth of topsoil from the pond bottom. This stockpile is referred to as Topsoil Stockpile #1. The pond bottom is defined in the Construction Drawings. Harvest and stockpile an additional 6-inch depth of topsoil from the pond bottom. This stockpile is referred to as Topsoil Stockpile #2. Topsoil Stockpile #1 and Topsoil Stockpile #2 shall not be mixed. Place topsoil from Topsoil Stockpile #1 as the top 6-inches of finished grade on all areas as defined in the Construction Drawings. Haul all remaining topsoil from Topsoil Stockpile #1 to the offsite stockpile location. Place topsoil from Topsoil Stockpile #2 as the top 6-inches of finished grade on all areas with wetland/riparian seed or wetland plugs as shown on the Construction Drawings. Haul all remaining topsoil from Topsoil Stockpile #2 to the offsite stockpile location. Topsoil from Stockpile #1 nor Stockpile #2 shall be mixed with other offsite stockpiles.

Modify Subsection 622.03 to reflect the Following:

Site-specific Construction Considerations, including but not limited to compaction requirements, from the project Geotechnical Evaluation Report shall supersede requirements from this section where they are in conflict.

Under Subsection 622.03 Add the Following:

When completing construction during wet or cold weather, grade the site such that surface water can drain readily away from the work areas. Promptly pump out or otherwise remove any water that may accumulate in excavations or on subgrade surfaces and allow these areas to dry before resuming construction. The use of berms, ditches and similar means may be used to prevent stormwater from entering the work area and to convey any water off site efficiently.

If earthwork is performed during the winter months when freezing is a factor, no grading fill, structural fill or other fill should be placed on frozen ground, nor should frozen material be placed as fill. Frozen ground should be allowed to thaw or be completely removed prior to placement of fill. A good practice is to cover the compacted fill with a “blanket” of loose fill to help prevent the compacted fill from freezing.

If structures are erected during cold weather, foundations or other concrete elements should not be constructed on frozen soil. Frozen soil should be completely removed from beneath the concrete elements, or thawed, scarified and recompacted. The amount of time passing between excavation or subgrade preparation and placing concrete should be minimized during freezing

conditions to prevent the prepared soils from freezing. The use of blankets, soil cover or heating as required may be utilized to prevent the subgrade from freezing.

Excavation or Embankment (Fill) work either completed or in a stage of completion that is either eroded or washed away or becomes unstable due to either rains, snow, snow melt, channel flows or lack of proper water control shall be either removed and replaced, re-compacted or reshaped as directed by the **Engineer** and in accordance with the Drawings and Specifications at **Contractor's** sole expense. Removed unsuitable materials shall be hauled away and disposed of at **Contractor's** expense. Placing of replacement materials for removed unsuitable materials shall be purchased, placed and compacted at **Contractor's** expense. All embankment fill material shall be compacted in a maximum of 8-inch loose lifts to a minimum of 95% maximum dry density modified proctor per ASTM 1557. Moisture content shall be within a range of $\pm 2\%$ optimum moisture content.

Subgrade should be prepared as described in Section 4.2.2 of the project Geotechnical Evaluation Report. Probing with a steel rod will be required to verify stable foundation material, if designated on the Drawings or when ordered by the **Engineer**. Areas found to be soft and/or unstable and those areas which failed shall be ripped, scarified, wetted if necessary, and re-compacted to the requirements for density and moisture at **Contractor's** expense.

Probing shall be done with equipment and in a manner acceptable to the **Engineer**. Probing as ordered by the **Engineer** shall not be measured and paid for separately but shall be included in the unit prices bid for the work.

Under Subsection 622.05

Modify section to reflect that testing shall be ordered and performed at the contractor's expense based upon the testing schedule section 2.09 of the project Special Provisions. Quality Assurance testing may be ordered by the City and performed at the owner's expense.

REVISION OF SECTION 624 riprap and grouted riprap channel construction

Modify section 624.

ADDITION OF SECTION 626 – ROCK

Section 626 is hereby added to the Standard Specifications and shall include the following:

626.01 Description

The work of this section consists of installation of water control measures, subgrade preparation, riprap, boulders, boulders to be grouted, grout, weep/underdrains (if included), sculpted rock, and miscellaneous appurtenant items as indicated herein and on the Drawings.

The terms “Boulder Grout” or “grout” – when referenced related to grouting rock, boulders, core rock, etc., as used in these specifications, refers to a type of concrete to be used as a filler and cementing agent between boulders. The grout, and all related Boulder Grout work, shall meet the requirements of this Section and Section 600 – Structural Concrete, including, but not limited to: mix design, quality assurance and control, submittals, materials, job conditions, placement, curing and testing.

The term “rock” includes all boulders, rip rap, core rock, cobble, and other types defined in section 626.02. The term “boulders” includes Surface Boulders, Rounded Surface Boulders, and Feature Boulders as determined in section 626.02.

626.01.01 SUBMITTALS AND TESTING:

- A. General: Submittals shall be prepared and submitted in accordance with the Submittal Procedures.
- B. In advance of delivery of imported rock to the work site an inspection of the quarry or source of any imported rock shall be arranged by the Contractor and shall include the Contractor, Engineer, and Quarry Representative.
- C. Rock Work Plan: The Contractor shall prepare a Rock Work Plan for the project. The plan shall provide the Contractor’s methods and procedures for managing the sourcing, supply, stockpiling, delivery, and installation of rock work for the project including the following:
 - 1. Rock shall be imported from a quarry. Identify material sources and expected quantities for each type of rock. Estimated quantities will be made at the earliest time practicable for each area to be constructed, and the Rock Work Plan will be updated or amended to reflect quantities.

For each type of imported rock, include certificates stating the source of the rock and that the rock will meet the requirements of this section. Include test results for specific gravity, abrasion, gradation and freeze thaw on samples of rock to be supplied on this project.
 - 2. The Contractor and quarry or rock supplier shall identify procedures that will be used to stockpile, mix and grade the types of riprap and boulders specified.
 - 3. Sketches or exhibits indicating material stockpile and staging areas.
 - 4. Describe methodologies and techniques for installation of each rock type.
- D. Submit design mix for Boulder Grout per requirements of Section 600 - Structural Concrete.
- E. Visual Checking: Boulders shall be visually checked by the Contractor at the quarry or source of imported rock, or at the work site as required for size, elongation, cracks, deterioration and other defects visible on the entire surface area of the stone. If cracks are observed, the Contractor

shall notify the Engineer to make a determination as to acceptability of rock. Boulders with cracks or defects that are detrimental to a long-lasting product shall not be shipped to the work site.

- F. Physical Checking: Boulders shall be physically checked as requested by the Owner at the work site by dropping one boulder on top of another from a height of 6-feet between the boulders. If cracks are observed, the Owner shall make a determination as to acceptability of rock. Boulders with cracks or defects that are detrimental to a long-lasting product shall not be utilized.

626.02 MATERIALS

626.02.01 ROCK:

- A. General: Rock shall be imported. Imported rock shall be derived from offsite sources such as quarries, pits excavations, or surface sources. All rock must be screened and/or sorted and stockpiled into the various rock types to be used on the project. Graded materials shall be stockpiled in a manner to avoid segregation.

All rock and boulders are to be sound and durable against disintegration under conditions to be met in handling and placing. Rock and boulders shall be hard and tenacious and otherwise of a suitable quality to ensure permanency in the specified kind of work. Rock and boulders shall be free of calcite intrusions, cracks, joints, and other defects that could promote accelerated weathering and deterioration of the rock. Rhyolite rock shall not be allowed. .

The color of imported boulders and riprap (other than Core Rock) shall match closely with existing rock in the project site as approved by the Engineer. Color shall be consistent on the entire PROJECT and shall match the color of rock to be used for all other portions of the WORK.

For Rip Rap and Core Rock, each rock/boulder shall have its greatest dimensions not greater than 3 times its least dimension.

All rock and boulders shall conform to the following test requirements of the American Society for Testing Materials (ASTM) and American Association of State Highway and Transportation Officials (AASHTO) Standards:

	Requirement	Testing Standard
Apparent Specific Gravity	2.60 minimum	ASTM C-127
Abrasion Loss	40% maximum	ASTM C-535
Freeze Thaw Loss	10% maximum after 12 cycles	AASHTO 103 Procedure A

All rock and boulders to be used on the project must be approved by the Engineer. Once approved, the rock shall be kept consistent through the project. No change may be made to the rock source unless specifically approved by the Engineer.

- B. TYPES: The following types of rock shall be imported for this project.
 1. Surface Boulders. To be used for grouted boulder or loose boulder installations in areas where smoothness or aesthetics of finished rock work is desired. The minimum size of surface boulders to be used on this project is shown on the Drawings or details but shall be at least 36-inches in all dimensions.
 2. Riprap: Imported rock meeting the following gradation:

CLASSIFICATION OF GRADATION OF ORDINARY RIPRAP (IMPORTED)

Riprap Designation	% Smaller than Given Size by Weight	Intermediate Rock Dimensions (inches)	d ₅₀ (inches)*
Type VL	70 - 100	12	6
	50 - 70	9	
	35 - 50	6	
	2-10	2	
Type L	70 - 100	15	9
	50 - 70	12	
	35 - 50	9	
	2 - 10	3	
Type M	70 - 100	21	12
	50 - 70	18	
	35 - 50	12	
	2 - 10	4	
Type H	70 - 100	30	18
	50 - 70	24	
	35 - 50	18	
	2 - 10	6	
Type VH	70 - 100	42	24
	50 - 70	33	
	35 - 50	24	
	2 - 10	9	

* d₅₀ = Mean Particle Size

3. Additional Requirements for Rip Rap:

- a. Each load of riprap shall be reasonably well graded from the smallest to the largest size specified.
- b. Stones smaller than the two to ten percent (2 - 10%) size will not be permitted in an amount exceeding ten percent (10%) by weight of each load.
- c. Control of gradation shall be by visual inspection. However, in the event ENGINEER determines the riprap to be unacceptable, ENGINEER shall pick two (2) random truckloads to be dumped and checked for gradation.
 - i. Mechanical equipment and labor needed to assist in checking gradation shall be provided by CONTRACTOR at no additional cost.
- d. Unless otherwise noted on the Drawings, riprap shall be placed in the following minimum thickness (not including bedding thickness as applicable):

Riprap Designation	Riprap Layer Thickness (inches)
Type VL	12
Type L	18
Type M	24
Type H	36
Type VH	48

4. Granular Bedding Material: Granular bedding designation and total thickness of bedding shall be as shown on the Drawings. Granular bedding shall meet the same requirements for specific gravity, absorption, abrasion, sodium sulfate soundness, and freeze – that durability as required for riprap and specified above.

Gradation for Granular Bedding:

U.S. Standard Sieve Size	Percent Weight by Passing Square-Mesh Sieves	
	Type I (CDOT)	Type II (CDOT)
3-inch	-	90 – 100
1-1/2 inch	-	-
3/4 inch	-	20 – 90
3/8 inch	100	-
No. 4	95 – 100	0 – 20
No. 16	45 – 80	-
No. 50	10 – 30	-
No. 100	2 – 10	-
No. 200	0 – 2	0 - 3

C. **QUALITY CONTROL:** The Contractor shall manage the delivery and stockpiling of rock at the site to assure that adequate supply of rock meeting the specification is available for installation when required. Stockpile locations shall be arranged to avoid interference with other project operations. Rock which does not meet specifications or is not installed shall be removed from the site.

626.02.02 BOULDER GROUT (Grout):

- A. Concrete used for grouted rocks and boulders – “Boulder Grout” or “grout” shall be an approved batch and meet all the requirements for ready-mixed concrete as specified in Section 600 – Structural Concrete, except as modified below.
- B. Strength and General Requirements.
 - 1. Design and proportion Boulder Grout to meet the following minimum compressive strengths and other criteria.

Location	Aggregate Size inch– (ASTM C33 size)	Design Strength 28-day (psi)	Required Strength 7-day (psi)	Slump ± 1-inch h	Minimum Cement Content* (lbs/yd)	Flyash Content	Maximum Water Cement Ratio*
Boulder Grout **	#67	4,500	3,000	2-10	611	20% max.	0.38

* The maximum water-cementitious materials ratio by weight, which shall be based on all water in the mix, including correction for moisture in aggregates, and shall be based on the total cementitious materials including cement and fly ash, if any.

** Add synthetic fiber reinforcement. See Boulder Grout Admixtures.

- 2. Entrained Air for Boulder Grout.
 - a. Entrained air, 6 ± 1½ percent for ASTM C33 Size 67 coarse aggregate. Refer to ACI 301 for air entrainment required for other coarse aggregate sizes.
- 3. The slump of the Boulder Grout will be adjusted depending on the number of rock or boulder layers grouted in a single pour. All Boulder Grout shall meet the specified requirements for slump, durability, strength, water-cement ratio and other properties. Boulder Grout slump shall vary per the following table:

Boulder Grout Location	Slump

Single Boulder Layer	2" to 5"
Multiple Boulder Layer	6" to 10" Note: When grouting on steeper slopes, and at the direction or approval of the Engineer, the Contractor shall use a slump in the range specified for Single Boulder Grouting, but only in those portions along the surface of the slope.

4. When Boulder Grout arrives at the project with slump below 1-inch, first the Boulder Grout shall be remixed for at least one minute at mixing speed; if the slump is still too low, water may be added only if the maximum permissible water-cement ratio is not exceeded. The water-cement ratio must be verified by truck batch tickets and corrections for moisture in the aggregates. The water must be incorporated by additional mixing equal to at least half of the total mixing required. Any water addition must be reviewed and approved by the Engineer.
5. When grouting multiple boulder layers, such as in areas using core rock, Boulder Grout shall arrive at the job site at a slump of less than 2-inches, be verified, then the high-range water-reducing admixture (super-plasticizer) added to increase the slump to the approved level for placement. Water shall not be added for this purpose. Contractor shall review recommendations of the admixture supplier and ready-mix producer with Engineer. Batch plant additions of part or the entire high-range water-reducing admixture may be considered if found acceptable by the Engineer and if shown to produce equal or better results.
6. Slump shall be adjusted by the Contractor within the ranges given above to assure complete penetration of the Boulder Grout through each rock layer, into the layer below, and to the underlying subgrade.
7. Do not re-temper mix by adding water once slump is attained in each truck load.

C. Boulder Grout Admixtures:

1. Fibrous Concrete Reinforcement: For all locations where fiber reinforcing is called out on the drawings or in the specifications, add 100 percent virgin polypropylene, fibrillated fibers to the concrete. Volume per cubic yard shall equal a minimum of 0.10% (1.5 pounds/CY). Fiber length shall be graded per manufacturer. Fiber manufacturer must document evidence of 5-year satisfactory performance history, compliance with applicable building codes, ASTM C 1399, and ASTM C 1116/C 1116 M, Type III fiber reinforced concrete. Fibrous concrete reinforcement shall be Fibermesh 300 or Fibercast 500 manufactured by Propex Concrete Systems, Chattanooga, TN or approved equal. Product use shall be in accordance with manufacturer's instructions and recommendations.

626.02.03 SOIL RIPRAP:

- A. Rock requirements are to comply with riprap as specified in Part 2.01 Rock.
- B. Soil riprap shall be placed in the minimum thicknesses as noted on the Drawing plans, details, and sections.
- C. The soil material shall be native or imported topsoil and mixed with sixty-five percent (65%) riprap and thirty five percent (35%) soil by volume.

- D. Unless specified elsewhere, seed for buried riprap shall consist of a mix of native grasses as proposed by a local, well qualified supplier. Rates and application will be as recommended by the supplier.

626.02.04 VOID-PERMEATED RIPRAP:

Void-Permeated Riprap differs from Soil Riprap and Void-Filled Riprap in that most of the voids are filled after placement of the riprap layer. The material to be washed into the voids shall be referred to as permeate material.

- A. Rock requirements are to comply with riprap material specifications in Part 2.01 Rock.
- B. Samples of riprap and permeate material shall be submitted for the review and approval of the ENGINEER prior to construction.
- C. Where "Void-Permeated Riprap" is designated on the Drawings, riprap shall be mixed with the Permeate Materials prior to initially placing riprap.
- D. Permeate material shall consist of sands, rounded gravels, and rounded river cobbles. Void permeate materials shall meet the gradation requirements specified in the following table. If permeate materials are harvested on-site, the material shall be well mixed and stockpiled on site with the gradation of the permeate material visually approximated and agreed upon with the Engineer. If agreement cannot be reached, a sample shall be taken and the gradation shall be established.
- E. Void-permeated riprap shall be placed in the minimum thicknesses as noted on the Drawing plans, details, and sections. The materials required for each step in the placement procedure include:

Approximate Proportions	Material Type	Material Description
Initially Placed Riprap		
75-90% of Initially Placed Riprap	Riprap	Type VL, L, M, or H as Indicated on Drawings
10-25% of Initially Placed Riprap	Permeate Materials: Pit Run well mixed and placed with riprap or: VTC (Vehicle Tracking Control rock)	4-inch minus pit run surge (round river rock and sand, well graded, 90-100% passing 4-inch sieve, 70-80% passing 1.5-inch sieve, 0 -60% passing 3/8-inch sieve, 10-30% passing #16 sieve). or: VTC (Vehicle Tracking Control) rock (crushed rock with 100% passing 4-inch sieve, 50-70% passing 3-inch sieve, 0-10% passing 2-inch sieve)
Permeate Material (To be Washed into Voids after Initial Placement)		
25%	Permeate material	2 to 4-inch cobble (round washed river rock that is well-graded, 100% passing 6-inch sieve, 35-50% passing 3-inch sieve, 5-20% passing 2-inch sieve)

25%	Permeate material	Harvested onsite channel/river bottom material or: 4-inch minus pit run surge (round river rock and sand, well graded, 90-100% passing 4-inch sieve, 70-80% passing 1.5-inch sieve, 40-60% passing 3/8-inch sieve, 10-30% passing #16 sieve) or: VTC (Vehicle Tracking Control) rock (crushed rock with 100% passing 4-inch sieve, 50-70% passing 3-inch sieve, 0-10% passing 2-inch sieve)
50%	Permeate Material	Harvested sands and gravels collected from locations identified on site.
Material Placed on top of Riprap Layer after Plating		
Top layer	Top dressing	Same as the permeate material.

* Percentage used shall be based upon mixing samples made prior to placement of riprap as determined by the Engineer. The Contractor shall prepare four samples of at least two cubic yards each. The Engineer shall inspect each sample and determine new mix percentages for next trial sample.

Void-permeated riprap shall be placed in the minimum thicknesses as noted on the Drawing plans, details, and sections.

626.02.05 FILTER FABRIC:

Use Mirafi 140 N non-woven filter fabric or engineer-approved equal where shown on the Drawings.

626.02.06 CURING COMPOUND:

Membrane-curing compound shall be in accordance with ASTM C309. Membrane curing compound shall be sprayable, 18 percent minimum solids content, as manufactured by L&M Construction Chemicals, Inc or equivalent acceptable to Engineer. Membrane curing compound used on colored concrete shall be as manufactured by L&M Construction Chemicals, Inc or equivalent acceptable to Engineer. Curing compound shall be non-toxic and must not cause discoloration of the Boulder Grout and boulders. When used on integrally colored, dry shake, or stained Boulder Grout, curing compound shall be approved by color additive/stain manufacturer and compatible with the color additives, stains, and any surface treatments/finishes used.

626.03 EXECUTION

626.03.01 SUBGRADE PREPARATION:

- A. WATER CONTROL: Prior to commencing work on rock placement, install water control measures as required to perform work in dry conditions. Water control measures shall include, but are not limited to, diversions, sumps with pumps or other means necessary to maintain the level of groundwater below subgrade elevation and to divert surface water away from the work area. The Contractor is responsible for investigating and understanding all site conditions that may affect the work, including surface water, level of groundwater and time of year the work is to be done. By submitting a bid, the Contractor acknowledges that such investigations have been made and consideration of such conditions are a part of the Contractor's bid.

- B. **SUBGRADE PREPARATION FOR RIPRAP, AND BOULDERS:** Excavate for placement of rock as indicated, providing a firm smooth compacted uniform surface at the proper grade. The subgrade shall be free of brush, trees, stumps, and other objectionable material. If unsuitable materials are encountered, they shall be removed and replaced in accordance with Section 31 00 00 - Earthwork, for subgrade that has been excavated in undisturbed soil. The subgrade shall be undisturbed native material, unless in fill areas or as otherwise shown on the Drawings. Excavation and subgrade shall at a minimum meet the requirements of Sections 621 -Channel Excavation and 622 – Channel Embankment and Backfill. In fill areas under riprap and non-grouted boulders, the subgrade is to be compacted to 95 percent maximum density (ASTM D698) or to 70 percent of its maximum relative density (ASTM D2049). In fill areas under or otherwise supporting grouted rock or sculpted concrete, the subgrade shall meet the stricter requirements of Subgrade under Structures as specified in Sections 621 – Channel Excavation and 622 – Channel Embankment and Backfill. Subgrade elevation and compaction shall be verified by the Engineer prior to placement of riprap or boulders.

For riprap areas, after an acceptable subgrade is established, bedding material shall be immediately placed and leveled to the specified elevation shown on the DRAWINGS. Immediately following the placement of the bedding material, the riprap shall be placed. If bedding material is disturbed for any reason, it shall be replaced and graded at CONTRACTOR's expense. In-place bedding materials shall not be contaminated with soils, debris or vegetation before the riprap is placed. If contaminated, the bedding material shall be removed and replaced at CONTRACTOR's expense. If a scarified subgrade is required, the subgrade shall be prepared and compacted to the elevations required as specified or shown for riprap. Afterwards, the surface shall be uniformly scarified to the depths required using sufficiently sized equipment. Tractors, bulldozers, or similar equipment shall pull a tillage implement or be fitted with a tool bar containing tines, rippers or other devices capable of loosening and mixing the soil to the required depth. Other methods may be acceptable if approved by the Engineer.

626.03.02 RIPRAP PLACEMENT:

- A. Install water control measures. Prepare subgrade and machine place stones into position following details on Drawings. Arrange as necessary by machine or by hand to interlock. The finished area shall be well graded and free from objectionable pockets of small stones and clusters of larger stones. Dumping and/or backhoe placement alone is not sufficient to ensure proper interlocked placement. The basic procedure shall result in larger materials flush to the top surface with faces and shapes arranged to minimize voids, and smaller material below and between larger material. Surface grades will be a plane or as indicated on drawings, but projections above or depressions under the finished design grade more than 10% of the rock layer thickness will not be allowed. Smaller rock shall be securely locked between the larger stone. It is essential that the material between the larger stones is not loose, or easily displaced by flow or by vandalism. The stone will be consolidated by the bucket of the backhoe or other means that will cause interlocking of the material. The outside edges of the material are to be uniform and free from bulges, humps, or cavities. All rock is to be placed in a dewatered condition beginning at the toe of the slope or other lowest point unless otherwise specified in the Drawings or Specifications. Riprap shall be placed to full course thickness in one operation and in such a manner as to avoid displacing the underlying bedding material. Placing of riprap in layers, or by dumping into chutes, or by similar methods shall not be permitted.

626.03.03 SOIL RIPRAP:

- A. Adjacent stockpiles of riprap and soil shall be created and mixing done at the stockpile location, not at the location where soil riprap is to be placed
- B. Mix thirty-five percent (35%) soil by volume with stockpiled riprap, using additional moisture and control procedures that ensure a homogenous mixture, where the soil fills the inherent voids in the riprap without displacing riprap.

- C. With prior approval of Engineer, layering the riprap and soil instead of premixing may be allowed if the native soil is granular.
- D. Place a first layer of smaller soil riprap of approximate d50 thickness. Then place the top layer with surface rocks that are largely d50 or greater, filling voids as necessary with smaller riprap. Create a smooth plane as described in Part 3.03 Riprap Placement.
- E. The mixture shall be consolidated by large vibratory equipment or backhoe bucket to create a tight, dense interlocking mass.
- F. The soil shall be further wetted to encourage void filling with soil.
- G. Any large voids shall be filled with rock and small voids filled with soil.
- H. Excessively thick zones of soil prone to washing away shall not be created (for example, no thicknesses greater than six (6) inches).
- I. Where indicated on the Drawings as exposed or not designated as buried, the final surface shall be thoroughly wetted for good compaction, smoothed, and compacted by vibrating equipment; the surface shall then be hand raked to receive planting or seeding. Hand broadcast seed mix and mulch as specified and shown on the drawings Final grade shall be covered with erosion control blanket and secured with biodegradable stakes.

626.03.04 VOID-PERMEATED RIPRAP:

- A. Void-permeated Riprap is riprap meeting other material and installation requirements specified elsewhere in this specification with the following additional material and installation requirements:
- B. Follow requirements of 3.01 SUBGRADE PREPARATION, and 3.02 RIPRAP PLACEMENT except as modified herein.
- C. Scarify upper layer of prepared subgrade to facilitate plating of riprap.
- D. Place bedding if required on details.
- E. Approved individual component materials of the initially placed riprap shall be delivered to site in separate marked stockpiles. Mixing shall be accomplished using a front-end loader or other approved means to add the specified percentages of each material to a mixing stockpile. Avoid picking up native soil from the subgrade under the stockpiled materials during the loader bucket mixing operations.
- F. Place riprap as specified and shown on the drawings in equally deep lifts no thicker than 15-inches.
- G. Wash and rod Permeate Material into riprap by evenly placing material with water on top of the riprap and dumping loader or backhoe buckets of water over the Permeate Material and riprap. Continue washing the Void Permeated Material until more material will not wash into the riprap.
- H. Repeat the placement and washing and rodding of the Permeate Material of the next layer of riprap until the design thickness is obtained.

- I. For the top layer of riprap: distribute and flatten riprap to a relatively uniform surface using a backhoe bucket or other approved means following a definite pattern, with the voids between the larger stones filled with the Void Permeated Material.
- J. Plating of Riprap: Plated (also referred to as keyed riprap), is mechanically placed riprap that has been keyed in place by slapping the surface with a large piece of armor plating that is repeatedly dropped. A 5000-pound steel plate (approximately 4' x 5' x 6") is used to compact the rock into a tight mass and to smooth the rock surface. The plate need only be dropped approximately 3 to 4 feet to be effective.
 - a. Plating is complete when striking action has resulted in a reasonably uniform surface, true to the dimensions shown in the plans, and the tops of the rocks have less than 1-1/2-inches of variation.
 - b. If approved by the Engineer and adequate performance is demonstrated, a backhoe equivalent or larger than a 235C Caterpillar excavator with a vibratory hydraulic plate compactor weighing at least 1,700 pounds and creating an impulse force of at least 18,000 lbs at a frequency of 2100 cpm or greater or full loading of an excavator bucket, can be used in place of the repeatedly dropped armored plate method. Plating is complete after all areas are compacted for at least 30 seconds and as specified above.
- K. After plated surface is accepted, fill remaining surface voids (1 to 3 inches) with the top dressing to the finished grade.
- L. For exposed void-permeated riprap where seeding is indicated on plans, prior to filling the top 1 to 3 inches. The final surface shall be thoroughly wetted for good compaction, smoothed, and compacted by vibrating equipment; the surface shall then be hand raked to receive planting or seeding. Hand broadcast seed mix and mulch as specified and shown on the drawings Final grade shall be covered with erosion control blanket and secured with biodegradable stakes.

626.03.05 BURIED RIPRAP:

When any type of riprap is designated on the drawings or specifications to be buried, the following requirements shall apply:

- A. The top surface shall be covered with topsoil to the depth indicated on the drawings such that no rock points are protruding. Hand broadcast seed mix and mulch as specified and shown on the drawings.
- B. Place onsite topsoil excavated material that is free from trash and organic matter in riprap voids by washing and rodding. Prevent excessive washing of material into stream. When voids are filled and the surface accepted by ENGINEER, place the specified depth of topsoil as designated on the DRAWINGS over the specified area.
- C. The topsoil surface layer shall be compacted to approximately 85% of maximum density and within two percentage points of optimum moisture in accordance with ASTM D698. Topsoil shall be added to any areas that settle.
- D. Fine grade the surface by hand raking to receive planting or seeding.
- E. Hand broadcast seed mix and mulch as specified and shown on the drawings Final grade shall be covered with erosion control blanket and secured with biodegradable stakes.

626.03.06 ALL BOULDERS AND ROCK TO BE GROUTED:

- A. Grouted rock (Core Rock, Feature Boulders, and Surface Boulders) installation shall be subject to approval by the Engineer at two stages:
 - 1. Following subgrade preparation and before placement of any rock; and,
 - 2. Before grouting the placed rock.
- B. The Engineer shall be notified a minimum of 48 hours before the scheduled placement of any rock for grouted rock installation to allow inspection of prepared subgrade. The prepared subgrade shall be subject to approval by the Engineer and no rock shall be placed without such approval.
- C. The Engineer shall be notified a minimum of 48 hours before the scheduled placement of any Boulder Grout for grouted rock installations. The arrangement, elevation and cleanliness of rock to be grouted shall be subject to approval by the Engineer and no Boulder Grout shall be placed prior to such approval.
- D. Prepare subgrade (see Part 3.1). Placement methods will avoid displacing the compacted subgrade. Install fabric if/where shown on the Drawings.
- E. Boulders shall be set in contact with each other so that the interstices between adjacent boulders shall be as small as the character of the rock will permit.
- F. Tolerances for boulder placement shall be as indicated on the Drawings or specified herein. In some cases, it may be necessary to remove a boulder, adjust the subgrade elevation and re-set the boulder to achieve the required surface tolerance.

626.03.07 FEATURE BOULDERS, AND SURFACE BOULDERS TO BE GROUTED (ADDITIONAL-REQUIREMENTS):

- A. Prepare subgrade (see Part 3.1).
- B. Boulders shall be individually placed in a manner to avoid displacing underlying materials. Each boulder shall be placed to the final position by the use of a multi-prong grapple device or suitable equipment for handling individual boulders. If necessary, the boulder shall be picked up and repositioned with minimal disturbance to the subgrade.
- C. Placement shall begin at the bottom of slope.
- D. Moving boulders by drifting or manipulation down the slope will not be permitted. Boulders shall not be dropped from a height of greater than 1 foot.
- E. Arrange each boulder as directed by Engineer. In general boulders will be arranged with a flat surface upward and horizontal. It should be anticipated that re-handling of individual stones after initial placement will be required to achieve required slopes, grades, elevations, and position.
- F. Where boulders are stacked and not interlocked behind boulders on the down slope, pinning of the boulders may be allowable as approved by the Engineer. Refer to the Drawings for additional information regarding pinning of boulders.
- G. Control Areas Tolerance: Elevations of top of boulders in Control Areas shall be within +/- 1-inch of design grade and design elevations on average as shown on the Drawings as determined by the Engineer. Evaluation shall be completed by averaging the finished surface elevations of boulders above and below the design surface elevations for the cross-section (cut nominally perpendicular to flow or centerline) of any bank or feature over a width of approximately 3x the

minimal boulder diameter. The Engineer shall use visual inspection, survey or other measurement techniques for evaluation of tolerances of Control Areas. Control Areas include, but are not limited to, any areas identified on the Drawings or by Engineer as Control Areas, crests of drop structures, water control structures, tuning areas, wall caps, boat chutes, areas adjacent to boat chutes and areas adjacent to whitewater features. Prior to placing boulders with dimensions that exceed the minimum specified, excavate the subgrade as required to achieve top surface.

- H. Non-Control Areas Tolerances: Non-Control Areas of boulders are any area not defined as a Control Area by the Specifications or Drawings. Elevations of top of boulders in Non-Control Areas shall be within +/- 3 inches of design grade and design elevations on average as shown on the Drawings as determined by the Engineer. Evaluation shall be completed by averaging the finished surface elevations of boulders above and below the design surface elevations for the cross-section (cut nominally perpendicular to flow or centerline) of any bank or feature over a width of approximately 3x the minimal boulder diameter. The Engineer shall use visual inspection, survey or other measurement techniques for evaluation of tolerances of Non-Control Areas. Prior to placing boulders with dimensions that exceed the minimum specified, excavate the subgrade as required to achieve top surface.

626.03.09 BOULDER GROUT PLACEMENT:

- A. Boulder Grout placement shall meet all applicable requirements of Section 600 – Structural Concrete and in Section 2 above. See required notification requirements above.
- B. Unless otherwise shown on the Drawings, slump shall be adjusted onsite as specified in Section 2 above for single layer and multiple layer grouting. The use of stiffer mixes or other measures may be approved for individual or partial truck loads by the Engineer for steeper slope applications.
- C. Maintain water control measures before, during and after Boulder Grout placement until sufficient cure is obtained. Care shall be taken to remove all fines and smaller rock. Wash the rock free of fines or soil which would affect the bond. Any loose material between rocks shall be removed to ensure complete grout penetration down to compacted subgrade and in all voids between rocks.
- D. All boulders shall be wetted prior to Boulder Grout placement for proper bonding. Excess water or ponding on the subgrade shall be removed prior to Boulder Grout placement.
- E. The Boulder Grout shall be injected into the voids by pumping under low pressure, through a 3-inch maximum diameter hose to ensure complete penetration of the Boulder Grout to the subgrade. The voids at the surface, as detailed on the Drawings, will not be grouted unless designated. Operator shall be able to stop the flow and will place Boulder Grout in the voids and not on the surface of the rock. Clean and wash any spillage before the Boulder Grout sets. The visual surfaces of the rock will be free of Boulder Grout to provide a clean natural appearance. A "pencil" vibrator will be used to make sure all voids are filled between and under rock. The intent is to fill all voids with Boulder Grout from the subgrade level through the rock layer. In all cases, Boulder Grout must penetrate to subgrade. The pencil vibrator may be used to smooth the appearance of the surface, but the Contractor shall use a wood or steel float and/or trowel to smooth and grade the Boulder Grout surface to drain. Final surface shall be broomed or textured for a slip resistant finish.
- F. Boulder Grout shall be cured as specified in Section 600 - Structural Concrete. If curing compound is allowed, it shall not be sprayed into or washed off in the river. The curing compound shall dry for 24 hours minimum before allowing water to flow over it. In cold weather conditions, the entire grouted rock mass shall be protected from freezing as outlined in Section 600 - Structural Concrete.

- G. Provisions for Grouting Multiple Boulder Layers: Multiple layers of boulders having Boulder Grout depths up to 6 feet thick shall be grouted in a single operation in order to form a single monolithic structure.

Where the Boulder Grout depth is greater than 6 feet thick, grouting shall be completed in multiple lifts less than 6 feet unless otherwise approved by the Engineer. The initial layer(s) of rock to be grouted shall be placed and then grouted with the Boulder Grout held a minimum of 6-inches and not more than 50 percent of the rock diameter below the top of the rock. Boulder Grout placed for the subsequent layer will then penetrate down and around the tops of the first layer maximizing the strength of the joint. Successive layers of rock shall not be placed on top of grouted boulders until the Boulder Grout has cured at least seven (7) days or until the Boulder Grout reaches 80 percent of the design strength required by these Specifications.

- H. Surface water shall be diverted around the structure during construction and for at least seven (7) days or until the Boulder Grout reaches 80 percent of the design strength required by these Specifications.

ADDITION OF SECTION 627 – MOBILIZATION

Section 627 is hereby added to the Standard Specifications and shall include the following:

627.01 Description

Mobilization and Demobilization shall consist of the preparatory work and operations in mobilizing for beginning work on the Project and demobilizing at the end of construction. This work shall include, but not be limited to, those operations necessary for the movement of personnel, equipment, supplies and incidentals to the Project Site, and for the establishment of temporary offices, building facilities, utilities, testing laboratories, safety equipment and first aid supplies, sanitary and other facilities, as required by these Specifications, and State and local laws and regulations. The costs of bonds, plans, permits and any required insurance and other pre-construction expense necessary for the start of the work, excluding the cost of construction materials, shall also be included in this item.

ADDITION OF SECTION 640 – STRUCTURAL STEEL, MISCELLANEOUS METALWORK, AND EMBEDMENTS

Section 640 is hereby added to the Standard Specifications and shall include the following:

640.1 GENERAL

640.1.1 DESCRIPTION:

- A. This Section includes furnishing all materials, fabrication, and installation of structural steel, miscellaneous metalwork, and embedded metalwork including the stop logs for the project.

640.1.1 DESIGN CRITERIA:

- A. Structural Connections and Framing: AISC Specification for Structural Steel Buildings.

640.1.2 SUBMITTALS:

- A. Submit the following. All submittals shall be made in accordance with Project Special Provisions Section 2.22.
 - 1. Submit drawings detailing fabrication and erection of each metal fabrication indicated. Reproductions of drawings will not be accepted for this purpose.
 - a. Include plans, elevations, sections and details of metal fabrications and their connections. Show anchorage and accessory items.
 - b. Indicate welded connections using standard AWS welding symbols. Clearly indicate net weld lengths, sizes and welding sequences.
 - 2. Provide manufacturer's data sheets, handling and installation instructions for concrete anchors.

640.2 PRODUCTS

640.2.1 MATERIALS:

640.2.2 Unless otherwise indicated, materials shall meet the requirements in Table 1 and the following paragraphs:

Table 1 Structural Steel, Miscellaneous Metalwork, and Embedments

ITEM	SPECIFICATION
Structural Steel Shapes and Plates: Steel Plate for Lifting Lugs Wide Flange Shapes Other Rolled Shapes, Bars and Plates	ASTM A 242 ASTM A 992, Grade 50 ASTM A 36
Structural Steel Tubing (HSS): Round Shapes ($t \leq 0.625$ inch) Round Shapes ($t > 0.625$ inch) Square or Rectangular Shapes	ASTM A 500, Grade B ASTM A 53, Grade B ASTM A 500, Grade B
Steel Pipe	ASTM A 501 or A 53, Type E or S, Grade B
Stainless Steel: Bars and Shapes Steel Plate, Sheet and Strip Bolts and Threaded Rods Expansion Bolts Nuts	ASTM A 276, AISI Type 316 ASTM A 240 or A 666, AISI Type 316 ASTM A 193, AISI Type 316, B8M, B8MN, B8M2 or B8M3 ASTM A 582, Type 303 ASTM A 194, AISI Type 316, 8M, 8MN, 8M2 or 8M3
Steel Bolts, Nuts and Washers: Carbon Steel High-Strength Galvanized Steel Bolts and Nuts Machine Bolts Lag Bolts	ASTM A 307 or A 36 ASTM A 325, Type 1 ASTM A 307 or A 36, with ASTM A 153 zinc coating and ANSI B1.1 Federal Specification FF-B-575, Grade 5 ASME B18.21.1

ITEM	SPECIFICATION
Eyebolts Threaded Rods Flat Washers (Unhardened) Flat Washers (Hardened) Lock Washers (Helical Spring Type, Carbon Steel)	ASTM A 489 ASTM A 36 ASTM F 844; use A 153 zinc coating ASTM F 436 Federal Specification FF-W-84A
Steel Sheet: Uncoated, Structural, Cold-Rolled Uncoated, Nonstructural, Cold-Rolled Galvanized, Structural Quality	 ASTM A 1008, Grade A, unless otherwise indicated or required by design loading ASTM A 1008, Commercial Quality ASTM A 653, Grade A, unless otherwise required by design loading, with G-90 coating
Machine Screws, Cadmium Plated Steel	Federal Specification FF-S-92B
Aluminum Structural Shapes and Plates	ASTM B 209 and B 308, Alloy and Temper 6061-T6
Aluminum Bolts and Nuts	ASTM F 468 Alloy and Temper 2024-T4
Cast Iron	ASTM A 48, Class 35

640.2.3 Drilled Anchors:

640.2.3.1 Where indicated on the Drawings, drilled anchors shall be stainless-steel Titen HD screw anchors by Simpson Strong-Tie. Anchors shall have ICBO-approved testing.

640.2.3.2 Headed Anchor Studs: Headed anchor studs for embedded metalwork anchors shall be Nelson Stud Anchors or equal, and of the sizes shown on the Drawings.

640.2.4 Antiseizing Lubricant: Lubricant shall contain substantial amounts of molybdenum disulfide, graphite, mica, talc, or copper and shall be Permatex Antiseizing Lubricant by Loc Tite Co.; or equal. Apply to threads of stainless-steel bolts.

640.2.5 Welding Electrodes:

640.2.5.1 Welding electrodes for structural steel shall conform to AWS D1.1 Standards – AWS A5.1 or A 5.5 E70XX Series Electrodes.

640.2.5.2 Welding electrodes for aluminum shall be ER4043 filler metal.

640.2.5.3 Welding electrodes for stainless steel shall conform to AWS A5.4. Use electrodes E308 for Type 304 stainless steel and E316 for Type 316 stainless steel.

640.2.6 Stop Logs:

640.2.6.1 Stop logs shall be aluminum stop log Series 500 by Whipps, Inc.

640.3 EXECUTION

640.3.1 STORAGE OF MATERIALS:

640.3.1.1 Store material, either plain or fabricated, above ground on platforms, skids, or other supports. Keep materials free from dirt, grease, and other foreign matter and protect from corrosion.

640.3.2 FABRICATION AND ERECTION:

640.3.3 Fabricate miscellaneous metal items to straight lines and true curves. Drilling and punching shall not leave burrs or deformations.

640.3.4 Continuously weld permanent connections along the entire area of contact.

640.3.5 Exposed work shall have a smooth finish with welds ground smooth. Joints shall have a close fit with corner joints coped or mitered and shall be in true alignment. Unless specifically indicated on the Drawings, there shall be no bends, twists, or open joints in any finished member nor any projecting edges or corners at intersections.

640.3.6 Conceal fastenings wherever possible. Built-up parts shall be free of warp. Exposed ends and edges of metal shall be slightly rounded.

640.3.7 Clean the surfaces of metalwork to be in contact with concrete of rust, dirt, grease and other foreign substances before placing concrete.

640.3.8 Set embedded metalwork accurately in position when concrete is placed and support rigidly to prevent displacement or undue vibration during or after the placement of concrete. Unless otherwise specified, where metalwork is to be installed in recesses in formed concrete, said recesses shall be made, metalwork installed, and recesses filled with non-shrink grout in conformance with Section 600.02.03.C.

640.3.9 PAINTING:

640.3.9.1 All steel shall be painted with a electrostatic paint. The paint and its color shall be as shown on the Landscape Architect Drawings and approved by the Landscape Architect. The surface preparation for the steel and shop coating shall be as recommended by the paint manufacturer.

640.3.10 WELDING:

640.3.10.1 Perform welding on steel by the shielded metal arc welding (SMAW) process. Welding shall conform to the AWS Structural Welding Code-Steel, D1.1, except as modified in AISC Section J2.

640.3.10.2 Perform welding on aluminum by the gas metal arc (MIG) or gas tungsten arc (TIG) process. Welding shall conform to the AWS Structural Welding Code-Aluminum, D1.2.

640.3.10.3 Perform welding on stainless steel by the gas tungsten arc (TIG) process. All welds shall be full penetration and smooth unless otherwise indicated on the Drawings. Provide inert gas on the inside of pipe during welding to reduce oxidation.

640.3.10.4 Provide a minimum of two passes for metal in excess of 5/16-inch thickness.

640.3.10.5 Produce weld uniform in width and size throughout its length with each layer of weldment smooth; free of slag, cracks, pinholes, and undercuttings; and completely fused to the adjacent weld beads and base metal. Avoid irregular surface, nonuniform bead pattern, and high crown. Form fillet welds of the indicated size of uniform height and fully penetrating. Accomplish repair, chipping, and grinding of welds in manner that will not gouge, groove, or reduce the base metal thickness.

640.3.11 INSTALLING BOLTS:

640.3.11.1 Bolts shall be of the length that will extend entirely through but not more than 1/4 inch beyond the nuts. Draw boltheads and nuts tight against the work. Tap boltheads with a hammer while the nut is being tightened.

640.3.12 INSTALLING ANCHOR BOLTS:

640.3.12.1 Preset bolts and anchors by the use of templates. For mechanical equipment, do not use concrete anchors set in holes drilled in the concrete after the concrete is placed.

640.3.12.2 For static items, use preset anchor bolts where shown on the Drawings or drilled anchors with ICBO report data.

640.3.12.3 After anchor bolts have been embedded, protect projecting threads by applying grease and having the nuts installed until the time of installation of the equipment or metalwork.

640.3.12.4 Minimum depth of embedment of drilled mechanical anchors shall be as recommended by the manufacturer, but no less than that shown on the Drawings and no less than six and one-half bolt diameters.

640.3.13 ANCHORING SYSTEMS FOR CONCRETE:

640.3.13.1 Begin installation only after concrete or masonry receiving anchors has attained design strength.

640.3.13.2 Do not install an anchor closer than six times its diameter to either an edge of concrete, or to another anchor, unless shown otherwise.

640.3.13.3 Install anchors in accordance with manufacturer's instructions. Hole diameters are critical to installation, use only drills recommended by anchor manufacturer.

640.3.13.4 Follow specific manufacturer's safe handling practices when handling and installing anchors.

640.3.14 CONTROL OF FLAME CUTTING:

640.3.14.1 Do not use a gas-cutting torch in the field for correcting fabrication errors on any member in structural framing. Use a gas-cutting torch only on minor members when the member is not under stress.

640.3.15 CORROSION PROTECTION OF ALUMINUM SURFACES:

- 640.3.15.1 Coat aluminum surfaces to be embedded or which will be in contact with concrete or grout with bituminous paint having a minimum volume solids of 68 percent coal-tar pitch based.
- 640.3.15.2 Prepare surfaces to be coated with solvent or steam cleaning per SSPC SP-1; do not use alkali cleaning. Then dust blast.
- 640.3.15.3 Prime coat: surfaces to be coated by application of a synthetic resin or epoxy primer to metal surface before application of bituminous coating.
- 640.3.15.4 Finish Coat: Two coats of bituminous coating, 12 mils each.
- 640.3.15.5 Products and Manufacturers: Super Service Black by Carboline, St. Louis, MO; Tnemec 46-465 by Tnemec, North Kansas City, MO; Intertuf 100 by International Paint, Inc., Houston TX; or equal.
- 640.3.15.6 Allow the coating to dry before the aluminum is placed in contact with the concrete.
- 640.3.15.7 Where aluminum surfaces come in contact with dissimilar metals, except stainless steel, keep the dissimilar metallic surfaces from direct contact by use of neoprene gaskets or washers.

- END OF SECTION -

ADDITION OF SECTION 650 – SELECTIVE SITE DEMOLITION

Section 650 is hereby added to the Standard Specifications and shall include the following:

650.1 GENERAL

650.1.1 DESCRIPTION:

- A. This Section includes selective demolition of concrete, soil cement, miscellaneous metals and any other items required to complete the work in the Contract Documents.

650.1.2 SUBMITTALS:

- A. Submit to the Engineer the proposed methods and operations of demolition of the structures and modifications prior to the start of work. Include in the schedule the coordination of shutoff, capping and continuation of utility service as required. All submittals shall be made in accordance with Project Special Provisions Section 2.22

650.1.3 DISPOSAL OF MATERIALS:

- A. Removed materials shall become the property of the Contractor and shall be removed from the project site.

650.2 PRODUCTS (NOT USED)

650.3 EXECUTION

650.3.1 GENERAL

- A. Perform removal and salvage work specified herein and indicated on the Drawings in a manner that will not damage parts of the existing systems not intended to be removed and parts that are to be removed and salvaged. Items to be salvaged, which are damaged by the Contractor, shall be repaired or replaced with new undamaged items at the expense of the Contractor and as approved by the Engineer.
- B. If, in the opinion of the Engineer, the method of demolition used may endanger or damage parts of the existing systems to remain, parts of existing systems to be removed and reinstalled, or affect the satisfactory operation of the existing facilities, promptly change the method when so notified by the Engineer.
- C. Blasting will not be allowed as a method of demolition.
- D. Protect utilities and existing improvements that are not to be removed from injury or damage resulting from the Contractor's operation.
- E. During demolition supply safeguards required by applicable codes or regulations, including warning signs and lights, barricades, and the like, for protection of the public and Contractor's employees.
- F. Demolition shall comply with all federal, state and local regulations.
- G. The Owner and the Engineer assume no responsibility for the actual condition of the structures and materials to be demolished or modified.

650.3.2 REMOVING EXISTING CONCRETE:

650.3.2.1 The concrete shall be removed in a manner acceptable to the Engineer.

650.3.2.2 In general remove materials as follows

650.3.2.2.1 Locate and identify reinforcing bars in concrete prior to drilling and cutting, and protect structural integrity of existing work.

650.3.2.2.2 Use removal methods that will not crack or structurally affect adjacent concrete construction.

650.3.2.2.3 Cut back concrete to clean, straight lines by saw cutting a minimum of 1-inch deep; remainder of concrete may be jack-hammered.

650.3.2.2.4 Where the cut end of concrete reinforcement or other metal embedded items are exposed by demolition that will not be protected by new concrete, coat the exposed surface with an epoxy paste or remove the exposed metal item 2" below the surface of the concrete and patch with a cement grout.

650.3.3 REMOVAL OF METALS:

650.3.3.1 Anchors or other metal embedded items exposed by demolition that will not be protected by new concrete, remove the exposed metal item 2" below the surface of the concrete and patch with a cement grout.

650.3.4 REMOVAL OF SOIL CEMENT:

650.3.4.1 Removal of soil cement shall be such that the existing soil cement is not fractured or damaged. After the demolition has been completed the Engineer shall inspect the surface for damage. Damaged areas shall be repaired to the satisfaction of the Engineer. The surface of the soil cement that backfill or new concrete will be placed on shall be roughened to a ¼" amplitude.

- END OF SECTION -

REVISION OF SECTION 900 - SEEDING, FERTILIZER, BLANKET AND MULCHING

Section 900 of the Standard Specifications are hereby amended as follows:

Subsection 900.01 is revised as follows:

Delete the first paragraph and replace with the following:

"This work shall consist of soil preparation; furnishing and drilling or sowing seed; mulching or blanketing the seeded areas in accordance with these specifications, accepted horticultural practice, and in reasonably close conformity with the locations and details shown on the plans or as designated. The seeded areas shall be the limit of work and areas disturbed by access, staging, and stockpiling."

Delete the last paragraph

Subsection 900.02 is revised as follows:

Delete the seed mix shown in 900.02.A and replace with the following:

All seed mixes shall consist of certified seed varieties that are free of noxious weeds and have been tested for purity and germination within six (6) months of the planting date. Certification labels which indicate the species, purity, germination, weed content, origin, and test date shall be submitted for all seed materials. Refer to the DRAWINGS for the locations of the various seed mixes

Dryland Seed Mix.

Scientific Name	Common Name	% of Mix	PLS lbs/Acre
<i>Bouteloua gracilis</i>	Blue Grama-Hachita	4.4	1.0
<i>Pascopyrum smithii</i>	Western Wheatgrass-Arriba	25.7	5.9
<i>Bouteloua curtipendula</i>	Sideoats Grama-Vaughn	9.2	2.1
<i>Schizachyrium scoparium</i>	Little Bluestem-Pastura	10.9	2.5
<i>Oryzopsis hymenoides</i>	Indian Ricegrass-Paloma	6.6	1.5
<i>Nasella viridula</i>	Green Needlegrass-Lodorm	10.9	2.5
<i>Andropogon gerardii</i>	Big Bluestem-Champ	5.3	1.2
<i>Koeleria macrantha</i>	Junegrass-VNS	0.7	0.15
<i>Avena sativa 'Monida'</i>	Oats-Monida	26.3	6.0
		100.0	22.85

Riparian Seed Mix:

Scientific Name	Common Name	% of Mix	PLS lbs/Acre*
<i>Carex nebrascensis</i>	Nebraska sedge	5	0.5
<i>Distichlis spicata</i>	Inland saltgrass	10	1.0
<i>Eleocharis palustris</i>	Common spike-rush	10	1.0
<i>Elymus trachycaulus 'San Luis'</i>	Slender Wheatgrass-San Luis	5	1.0

<i>Glyceria striata</i>	Fowl Mannagrass-VNS	10	3.0
<i>Juncus balticus</i>	Baltic rush	10	0.1
<i>Juncus torreyi</i>	Torrey's rush	2	0.1
<i>Panicum virgatum</i> 'Blackwell'	Switchgrass-Blackwell	5	1.0
<i>Pascopyrum smithii</i> 'Arriba'	Western Wheatgrass-Arriba	10	5.0
<i>Puccinellia nuttalliana</i>	Alkali grass	5	0.1
<i>Schoenoplectus pungens</i>	Three-square bulrush	10	1.0
<i>Spartina pectinata</i>	Prairie Cordgrass-VNS	10	4.0
<i>Sporobolus airoides</i> 'Salado'	Alkali Sacaton-Salado	5	0.4
<i>Verbena hastata</i>	Blue verbena (swamp vervain)	3	0.1
		100	18.3

*Pure Live Seed (PLS) rate for drill seeding. If broadcast seeding, double the rate shown.

Water Quality Basin Mix:

Scientific Name	Common Name, Variety	PLS lbs/Acre*
<i>Cleome serrulata</i>	Rocky Mountain beeplant	4.00
<i>Distichlis spicata</i>	Inland saltgrass, native	1.00
<i>Elymus canadensis</i>	Canada wildrye, Mandan	3.50
<i>Elymus trachycaulus</i>	Slender wheatgrass, San Luis	3.00
<i>Galliardia aristata</i>	Blanket flower	2.00
<i>Helianthus annuus</i>	Annual sunflower, native	0.50
<i>Heliomeris multiflora</i>	Showy goldeneye	0.25
<i>Juncus arcticus</i>	Baltic rush, native	0.04
<i>Nassella viridula</i>	Green needlegrass, Lodom	2.50
<i>Panicum virgatum</i>	Switchgrass, Blackwell	1.00
<i>Pascopyrum smithii</i>	Western wheatgrass, Arriba	6.00
<i>Spartina pectinata</i>	Prairie Cordgrass, native	2.50
<i>Sporobolus airoides</i>	Alkali sacaton, native	0.35
<i>Verbena hastata</i>	Blue vervain, native	0.10
Total		26.74

*Pure Live Seed (PLS) rate for drill seeding. If broadcast seeding, double the rate shown.

Delete the following from section 900.02.A

"All slopes 2:1 and flatter shall be seeded by mechanical power drawn drills followed by packer wheels or drag chains. Mechanical power drawn drills shall have depth bands set to maintain a planting depth of at least one quarter inch and shall be set to space the rows not more than seven

inches (7") apart. Seed that is extremely small shall be sown from a separate hopper adjusted to the proper rate of application."

Add the following to section 900.02.A:

Seeding shall not be undertaken until adjacent site improvements and pavements are substantially complete. No trucking or moving of equipment or materials will be permitted upon completed seeded areas.

Seed shall be drilled mechanically with a mechanical, power-drawn drill followed by packer wheels. Seed shall be applied at the specified rate. Seeding will not be permitted when wind velocity is such as to prevent uniform seed distribution. No application shall be undertaken during inclement or the forecast of inclement weather. No application shall take place in the presence of free surface water or when the ground is frozen or un-tilled. Seed depth shall be 1/16"-1/4" and rows shall be spaced not more than 7" apart. Contractor shall drill half of the required PLS per acre in one direction, and then drill the remaining half of the required PLS per acre in a direction 90 degrees to the first half.

If seeding, raking in, and rolling operations are not performed in one (1) mechanical operation, the raking and rolling operations shall be performed separately and immediately after seeding operations.

Slopes 4:1 or greater and hand-seeded areas: Double seeding rates.

Some portions of project areas may be inaccessible to a drill. In these areas, which shall be agreed upon by contractor and engineer, seed shall be uniformly broadcast at twice the specified PLS per acre and covered with soil to a depth of one-quarter (1/4) inch to one-half (1/2) inch by hand raking or harrowing by some other means acceptable to engineer.

Broadcast seeding shall be accomplished using hand-operated "cyclone-type" seeders or rotary broadcast equipment attached to construction or revegetation machinery. All machinery shall be equipped with metering devices. Broadcasting by hand shall be acceptable on small, isolated sites. Prior to hand broadcast seeding, divide the seed required into two portions. Apply the first half of the seed and then follow up by applying the second portion to ensure complete coverage by seed. When broadcast seeding, passes shall be made over each site to be seeded in a manner to ensure an even distribution of seed. When using hopper type equipment, seed shall be frequently mixed within the hopper to discourage seed settling and uneven planting distribution of species.

Broadcast seeding shall take place immediately following the completion of final seedbed preparation techniques and upon inspection and approval of engineer. Broadcast seeding should not be conducted when wind velocities would prohibit even seed distribution.

Do not seed areas in excess of that which can be mulched on same day.

Do not sow immediately following rain, when ground is too dry, frozen or during windy periods.

Roll seeded area with roller not exceeding 100 lbs.

Apply mulch immediately following seeding and rolling.

Delete 900.02.B in its entirety and replace with the following:

B. Soil Preparation

All areas to receive seed shall be prepared as described in this section.

A. Deliver, Storage, and Handling

Take adequate measures to control offensive odors caused by delivery, stockpiling and spreading of soil amendments.

- a. Materials shall be stored as recommended by the manufacturer.
- b. Avoid stockpiling soil amendments for more than seven consecutive days prior to spreading.

B. Submittals:

- a. Product data and test results showing mixture composition and analysis for all materials
- b. Delivery tickets on materials to verify quantities

a. Soil Amendment

- i. The final soil amendment for seeded areas will be based on soil testing and resultant recommendations described below. For the purposes of bidding, contractor shall assume that the soil amendment for seeded areas will include the following:

1. Humate Soil Conditioner

- a. Humate soil conditioner typically applied to the soil at a rate of 2,000 pounds per acre. The soil conditioner shall contain and biochar, humates, and mycorrhizae.

2. Class 1 Compost

- a. The organic material shall have an acidity in the range of pH 5.5 to 8.5, shall not exceed 3 mmhos/cm. salt content, shall not contain harmful levels of fecal coliform, salmonella, metals, or other materials of health concern, shall have AmmoniaN/NitrateN and carbon/nitrogen ratios that indicate maturity and stability of the compost, and shall have a minimum of 25% organic content. Sand, gypsum or peat moss are unacceptable materials. The mixture shall be free from clay subsoil, stones, lumps, plants and their roots, sticks, weed stolons and seeds, high salt content and other materials harmful to plant life. Apply at a rate of 2 CY/1,000 SF.

3. Organic Fertilizer

- a. Biosol Forte organic granular fertilizer, N-P-K Analysis: (7-2-1). Application Rate: Twenty (20) pounds of material per 1,000 square feet.

b. *Soil Testing*

- i.* The Contractor shall collect composite soil samples from representative locations throughout the site at completion of rough grading. If there are notable differences in soil appearance, separate samples shall be collected from each observed soil type. Coordinate with Owner's Representative for soil collection locations.
- ii.* The Contractor shall submit composite soil samples to an approved soil testing laboratory for nutrient and texture analysis.
- iii.* The Contractor shall notify the Owner's Representative seventy-two (72) hours in advance of the dates, times, and locations when/where composite soil samples will be collected.
- iv.* Laboratory results shall be submitted to the Owner's Representative within seventy-two (72) hours of receipt.

c. Bed Preparation for Seeded Areas

- i.* Loosen subgrade to a minimum depth of 12" with a deep harrow. Ripping and tilling shall be done in a direction that generally follows the natural contour of the site. Remove stones over 2" and sticks, roots, rubbish and all other extraneous materials.
- ii.* Provide soil amendment, temporary fencing, and all other accessories and materials necessary to assure complete and healthy growth of seeded areas.
- iii.* Spread compost and till or disk in thoroughly to a depth of 6", and bring to minimum depth required to meet lines, grades and elevations shown. Tilling or disking shall be done first in one direction and cross-tilled or disked in the perpendicular direction.
- iv.* Grade seeded areas to smooth, even surface with loose, uniformly fine texture. Roll, rake, drag lawn areas and remove ridges and fill depressions as required to meet finish grades. Finish grades to 1" below the top of adjacent pavement.
- v.* The prepared subgrade shall have no lumps or stones over two (2) inches. No seeding shall be installed on any area which has not been so prepared. Obtain the Owner's Representative written acceptance of prepared areas prior to proceeding.
- vi.* Top dress prepared soil with humate and fertilizer at rate specified in paragraph 900.02.B.a of this section.
- vii.* Notify the Engineer for review and acceptance of fine grading prior to seeding

Any areas that have been prepared and approved for seeding and because of weather or other causes are not immediately seeded are subject to re-inspection and acceptance by the Engineer. The Contractor shall notify the Engineer of his intent to seed following delays, allowing the Engineer sufficient time to inspect and approve the prepared areas. Any areas that in the opinion of the Engineer require re-grading or additional soil preparation because of wind and water erosion, or require additional tillage because of compaction, shall be done at the Contractor's expense.

- viii.* Seed Bed Guarantee:
 - a.* Upon completion of soil preparation work, the Contractor shall guaranty that no rock, concrete, construction materials or other

rubble lie within the top six inches of the surface of the prepared areas.

- b. Contractor shall also guaranty against settlement for one full year after initial acceptance. Any corrections required to meet this specification, including repair/replacement of seed shall be at the Contractor's expense.

d. Maintenance and Acceptance

Maintenance period: Shall begin immediately after site preparation of each area and shall continue until Final Acceptance.

Maintenance Requirements until Final Acceptance:

- i. Weed Control: Apply appropriate herbicide(s) in accordance with manufacturers suggested rate(s) to control weeds. Herbicide application must comply with all requirements of herbicide/pesticide applicators license, including suitable warning/signing following application.
- ii. Disease and Insect Control: Apply fungicides and insecticides as required to control diseases and insects by a licensed applicator in accordance with state law requirements.
- iii. Watering: The Contractor shall be responsible for watering of seeded areas if he deems it necessary to insure performance under this Section. Apply only the amount of water necessary to maintain seeded areas in a healthy condition until the work has been accepted. Reduce amount of water after seed is established. Avoid standing water, surface wash, or erosion from over-watering.
- iv. Protection: Provide sufficient barriers and signage notifying the public to keep off newly seeded areas.
- v. Repair: Re-seed or plant areas that have washed out or are eroded or otherwise do not have adequate coverage of vegetation.
- vi. Inspection: The Contractor shall notify the Engineer prior to watering, mowing, fertilizing, and spraying operations.
- vii. Maintenance by Owner: After notice of Final Acceptance is given by the Engineer, further maintenance shall be provided by the Owner. Contractor shall submit written notice to the Engineer if maintenance is not being performed adequately to industry standards.

Conditional Re-vegetation Acceptance: Upon completion of all seeding operations, the Contractor shall notify the Engineer to review the work. If all work is acceptable, the Engineer shall record that date and issue a "Substantial Completion" certificate.

Final Re-vegetation Acceptance: Seeded areas shall receive final acceptance provided all requirements, including maintenance, have been complied with, and a healthy, viable stand of grass is established, free of weeds, undesirable grass species, disease and insects. Seeded areas shall meet the required coverage as stated below.

Areas seeded in the spring shall be inspected for required coverage the following fall not later than October 1st. Areas seeded in the summer or fall shall be inspected for required coverage the following spring not later than May 15th. Required coverage for seed areas shall be 60% aerial cover as measured from 5' directly overhead, with no bare spots. Determination of required coverage will be based on a random sampling of the entire project area. The following Spring prior to May 15th the seed areas shall be re-inspected for the required coverage. At this time 80% foliage cover as measured from 5' directly overhead shall be required. The same random sampling method will be used to determine coverage. When acceptable coverage has been met the Engineer shall issue a "Final Acceptance of Seeding Work" which shall end the seed establishment period and shall relieve the Contractor from future obligation for seeding work.

Guarantee:

- a. Upon completion of soil preparation work, the Contractor shall guaranty that no rock, concrete, construction materials or other rubble lie within the prepared areas.
- b. Contractor shall also guaranty against settlement for one full year after initial acceptance. Any corrections required to meet this specification, including repair/replacement of seed shall be at the Contractor's expense.

Delete section 900.02.C and replace with the following:

All seeded areas on the project not designated to receive erosion control blanket shall be mulched with hydraulic mulch and tackifier. The hydraulic mulch and tackifier shall materials and installation shall meet the requirements of the 2019 CDOT Standard Specification Section 213.

Subsection 900.03 is revised as follows:

Add the following to section 900.03:

Erosion control fabric shall be KoirMat 700 coconut fiber erosion control mating (woven matting of coir yarn) manufactured by Nedra Enterprises, Inc. or approved equivalent.

2"x4"x12" long wood stakes shall be used in place of staples as shown in the City Standard ECB detail. Roll matting onto slopes without stretching or pulling.

Lay matting smoothly on surface in direction of water flow. Bury top end of each section in 6 inch deep excavated topsoil trench. Provide six (6) inch overlap of adjacent rolls. Backfill trench and rake smooth, level with adjacent soil.

Lightly dress slopes with topsoil to ensure close contact between fabric and soil.

ADDITION OF SECTION 901 – COTTONWOOD POLES

Section 901 is hereby added to the Standard Specifications and shall include the following:

901.01 Description

Contractor shall furnish all labor, materials, supplies, equipment, tools and transportation; perform all operations to complete installation of live cottonwood poles; and guarantee all plantings.

Live stakes and poles are straight branches or saplings that have been cut and pruned from dormant living plant material (plants that have lost their leaves).

1. Substitutions

No substitutions for specified materials will be accepted in the bid. Alternative bid proposals, which propose material substitutions, may be submitted for consideration by Engineer. Alternative proposals must be fully supported by necessary documentation showing compatibility/comparability with specified materials.

2. Supervision and Workmanship

Contractor shall appoint a competent resident superintendent. The superintendent shall be on-site whenever the work is in progress. The superintendent will not be replaced without notice to Engineer. Workers shall be competent in performance of the work they are assigned.

3. Inspections and Observations

A. Site Inspection

1. Contractor, the landscape subcontractor and Engineer shall inspect site prior to being accepted by Engineer as complete and acceptable for the Landscape Contractor to proceed.
2. Beginning work of this section implies acceptance of existing conditions.

B. Pre-Planting Observation of Materials. Engineer shall observe and approve on-site harvesting areas, or off-site source of plant materials. Contractor shall coordinate with Owner for offsite sources of donor plants. Materials planted prior to approval are subject to rejection. All rejected materials must be removed from the site, replaced and re-inspected before planting.

C. Planting Observation

1. Engineer shall accept the location of all cottonwood pole plantings before installation.
2. Engineer shall inspect live branch cutting for acceptability upon arrival at the project site.

D. Final Walk-Through

1. The final walk-through will be performed at the completion of all planting operations under this contract.

2. At the time of the final walk-through, the landscape subcontractor shall have planting areas free of debris. Plant basins will be in good repair. Debris and litter will be cleaned up, and walkways, curbs, and roads will be cleared of soil and debris. The inspection will not occur until these conditions are met.
3. Engineer shall identify any deficiencies in the form of a punch list.
4. Engineer shall give written notice of final acceptance when work has been performed in compliance with the contract documents.
5. Deficiencies will be corrected within the first ten days of the final walk-through. Correct work in accordance with the contract documents at no cost to owner.
6. Final acceptance will not be given until all deficiencies are corrected. The landscape subcontractor shall maintain the site until final acceptance.

4. Guarantee and Replacement

- A. Guarantee plantings to root and thrive free from defects from any cause until final acceptance of the project.
- B. Replace plants when they are no longer in a satisfactory condition as determined by Engineer prior to final acceptance. This includes plants that die back and lose the form and size originally specified.
 1. Make replacements within seven days of notification from Engineer.
 2. Replace plants in the dormant season only, unless approved otherwise. Remove dead plants within two days of notification.
- C. All replacements will be of the same kind and size as originally specified and will be installed as described in the contract documents. Repairs and replacements will be made at no expense to owner.
- D. Guarantee will apply to the originally specified and installed plants and other landscape materials, and any replacements made during the construction period.

5. Planting and Completion

- A. Cottonwoods will be planted only when weather and soil conditions permit and in accordance with locally accepted practices, and as accepted by Engineer. Cuttings will not be planted when freezing temperatures are forecast twenty-four (24) hours in advance or when the ground is frozen or otherwise unsuitable.
- B. Cottonwoods will be harvested and planted in the dormant season, February 1 to April 1. However, best success is achieved when harvested and planted in March.

901.02 Materials

1. Cuttings

- A. Cottonwood material will be Plains Cottonwood (*Pupulus Deltoides*), live wood at least two (2) years old. Avoid suckers and current year's growth.

- B. Cottonwood poles will be ten-feet (10') long with a maximum of one-inch (1") diameter.

2 Handling and Storage

- A. Use extreme care to avoid damage to all remaining plants in harvest areas and the cuttings themselves. A maximum of forty percent (40%) of harvest plants will be removed for cuttings.
- B. Cutting will be kept moist, cool and shaded at all times until installed. Cuttings will be stored at between thirty-five degrees (35°) and fifty degrees (50°) Fahrenheit for no longer than one (1) week. Cuttings will be stored in protected locations where they are shaded and sheltered from sun and wind. The butt end (bottom end) of cuttings will be submerged in water for a minimum of twenty-four (24) hours but not longer than seven (7) days. The upper end of cuttings will not be submerged. Plastic trashcans work well for storing willow cuttings. Cuttings will be protected from freezing and drying at all times.
- C. Cuttings will not be dropped or otherwise mishandled. Minor broken and damaged cuttings will be pruned prior to planting. Major damage will be cause for rejection.
- D. Cuttings will be covered with tarp or burlap during any transportation in vehicles.

901.03 Execution

- A. Harvesting. All plant material must be collected and installed in dormant condition. Cuttings will be harvested with sharp pruning shears. The base cut will be at a forty-five-degree (45°) angle cut and any top cuts will be blunt. All material will be handled with care to avoid bark stripping and trunk wood splitting. Older, woody stems or stems with dead inner wood will not be used. Live cuttings will be bound together with twine at the collection site for ease of handling and protection during transport. The harvesting site will be left clean and tidy; excess woody debris material should be promptly removed from the site. Any soil disturbance outside of construction limits caused by accessing areas for willow harvesting will be ripped and re-seeded. There will be no additional payment for such disturbance.
- B. Cottonwood Poling. Poles will be planted at locations shown on the plans or as determined by Engineer. All branches must be trimmed from the pole except those at the tip. Prepare a pilot hole by using an auger, stinger, or probe to bore to a minimum depth of six (6) feet or as directed by Engineer. The pilot hole will be of sufficient diameter to facilitate easy insertion of cottonwood pole. Backfill around the installed pole with loose sand to eliminate air voids, then tamp the ground lightly around the pole with a hammer to hold it securely in place. A slight saucer will be formed around each pole to capture and hold precipitation. Unless otherwise accepted by Engineer, each cottonwood pole will be protected against beaver damage by the installation of a thirty-inch (30") diameter beaver protection sleeve made from an eight and one half-foot (8.5') length of forty-eight inches wide two (2) inches by two (2) inches welded wire fabric fastened with wire or hog-ring fasteners.

ADDITION OF SECTION 902 – PLANTING

Section 902 is hereby added to the Standard Specifications and shall include the following:

902.01 Description

Furnish all plant backfill material, trees, shrubs, grasses, wetlands, fertilizer, mulch, harvest live willow and cottonwood cuttings, labor, equipment, and non-plant materials required to complete installation of planting as indicated on the drawings.

A. Quality Assurance

1. Inspection:

- a. Plant materials shall be inspected by Engineer at the growing site and tagged or otherwise approved for delivery.
- b. Inspection at growing site does not preclude right of rejection at construction site.

B. Plant Qualification and Protection:

1. Plants shall have a habit of growth that is normal for the species and shall be of sound health, vigorous growth, and free from insect pests, diseases, and injuries. All plants shall equal or exceed the measurements specified in the plant lists, which are minimum acceptable sizes. They shall be measured and approved by the Engineer on site before pruning, with branches in normal position. Any necessary pruning shall be done at the time of planting. Requirements for the measurement, branching, grading, quality, balling, and burlapping of plants shall equal or exceed the code of standards currently recommended by the American Association of Nurserymen. Collected stock will not be permitted.
2. Substitutions will not be permitted without the written approval of Engineer.
3. Contractor shall submit written verification of plant stock origin to assure northern hardiness of all plant material prior to planting.
4. Protection after delivery: The balls of burlapped plants, which cannot be planted immediately on delivery, shall be covered with moist soil or mulch. All plants shall be watered as necessary until planted.

C. Submittals

1. Submit samples of nylon strap and wire to be used for tree guying for approval by the Engineer prior to planting.
2. Submit plant list, listing source of material, including origin of plants not grown in Colorado.
3. Submit credentials of licensed pesticide applicator at least one-week prior to application of pesticides on-site.
4. Submit fertilizer composition analysis 10 days before delivery to the site.

D. Planting Conditions

1. Planting operations shall be conducted under favorable weather conditions, approved by the Engineer.

2. Plants shall be installed only when soil and weather conditions permit and in accordance with locally accepted practices, and as approved by the Engineer.
3. If the Contractor has not received final approval for all work under the contract by October 15, they shall be responsible for wrapping all deciduous trees using materials by methods outlined in this section.
4. Installation of plant materials shall not be permitted until adjacent site improvements and pavements are substantially complete.

E. Damage to Other Improvements

All costs for repair or replacement of any damage to other work done on-site or on adjacent properties by installation of plant material shall be borne by Contractor installing plant material.

902.02 Materials

A. Prepared Plant Backfill

Prepared plant backfill shall consist of excavated existing site soil and soil amendment in the following proportions: 1/3 soil amendment, 2/3 existing site soil.

B. Soil Amendment

Acceptable organics are: Class 1 compost. The organic material shall have an acidity in the range of pH 5.5 to 8.5, shall not exceed 3 mmhos/cm. salt content, shall not contain harmful levels of fecal coliform, salmonella, metals, or other materials of health concern, shall have AmmoniaN/NitrateN and carbon/nitrogen ratios that indicate maturity and stability of the compost, and shall have a minimum of 25% organic content. Sand, gypsum or peat moss are unacceptable materials. The mixture shall be free from clay subsoil, stones, lumps, plants and their roots, sticks, weed stolons and seeds, high salt content and other materials harmful to plant life.

C. Water

Furnishing and distribution of the water for all portions of this section shall be the responsibility of the Contractor.

D. Staking, Guying and Wrapping

1. Wire supports shall be metal wire, sixteen (16) gauge.
2. Grommeted nylon straps, 1 ½" wide.
3. Staking pole support shall be 2" round wooden post, six (6) feet long.
4. Tree wrapping material shall be first quality 4" wide, bituminous impregnated tape, corrugated or crepe paper, brown in color, specifically manufactured for tree wrapping and having qualities to resist insect infestation.
5. Guy wire signals shall be ½" diameter white PVC, length as shown on the Drawings.

E. Mulching

Wood mulch: shall be shredded natural colored mulch. Submit sample to Owner for approval.

F. Fertilizer

Trees and shrubs: Osmocote Sierrablen, nine (9) month slow release

902.03 Execution

A. Acceptance

Obtain the acceptance of the Engineer of all plant materials and staked plant locations prior to beginning planting operations.

B. Tree and Shrub Planting Site Preparation

1. Dig pits and prepare planting soil prior to moving plants to their respective locations for planting to ensure that they will not be unnecessarily exposed to drying elements or to physical damage. Circular pits with vertical sides hard-trimmed shall be excavated for all plants. Diameter of pits for planting shall be at least twice the spread of balls or container, or as detailed on the drawings.
2. It is not anticipated that planting shall be done where the depth of soil over underground construction obstructions, or rock, is insufficient to accommodate the roots or where pockets in rock or impervious soil will require drainage. If such conditions are encountered in excavation of planting areas, and if the stone, boulders, or other obstructions cannot be broken and removed by hand methods in the course of digging plant pits of the usual size, other locations for the planting may be designated. Removal of rock or other underground obstructions and relocation of plant materials shall be done only as directed by the Engineer. If changes in the location of the work or if the removal of rock or other obstructions, other than existing underground utilities, involved additional work, the Contractor shall notify the Engineer for approval of extra payment.
3. In some locations, trees and shrubs will be planted in areas with riprap. In these locations, the riprap shall be removed from the planting pit. After placing the planting in the pit, the removed riprap will be reset into the plant pit around the root ball and mixed with planting backfill. The intent is to have riprap securely installed up to the root ball of the plant
4. Contractor shall dispose of excess excavated planting pit material at an approved off-site location or as directed by the Engineer.
5. Apply superphosphate to backfill mix according to manufacturer's instructions.

C. Setting Trees and Shrubs

1. All plants other than native cottonwood (*Populus deltoides*)

Unless otherwise specified, all plants shall be planted in pits to such a depth that the finished grade level at the plant after settlement will be the same as that at which the plant was grown. They shall be planted upright and faced to give the best appearance or relationship to adjacent areas. No burlap shall be pulled out from under balls. Remove all wire and surplus binding from tree ball with adequate wire cutters after tree is placed and stabilized in plant pit. When the hole is 1/2 filled, the soil mix shall be puddled with

water to eliminate air pockets as necessary and allow it to soak away. After the ground settles additional soil shall be filled into the level of the finished grade. Remove plants from container and spread out roots carefully and place in hole. Water plant thoroughly on day of planting.

2. Native Cottonwood (*Populus deltoides*)

Native plains cottonwood trees (*Populus deltoides*) to be planted in non-irrigated areas along water courses shall be deep planted to ensure good contact with groundwater and promote substantial root support. Deep planted trees shall be installed with up to one third (1/3) the height of the tree placed into a hole with the base of the root ball resting upon the level of the top of the groundwater. IT shall be verified that the root ball of the tree is placed in the capillary fringe (moist soil) just above the saturated soil zone (groundwater level). Deep planted trees shall be placed back from the edge of a water body far enough to permit at least a two (2) foot deep rooting zone above the water table. Deep planted trees are required to have at least two (2) feet of soil above the ground water level to provide a stable root zone for mature trees. Areas with heavy clay soils are not suitable for deep planting of cottonwoods.

D. Guying, Staking and Wrapping

Trees shall be supported immediately after planting. All trees shall be guyed and wrapped as detailed. Wire shall be passed through grommets in nylon straps to prevent direct contact with bark of the tree and placed around the trunk in a single loop. Wire shall be tightened and kept taut by twisting the strands together.

E. Mulch

Mulch shall be placed evenly around all plants as noted on the drawings to a 3" depth. Pull mulch away from the base of the plant.

F. Wetland and Riparian Plugs

1. Wetland or other potted plant materials shall be well watered before installation. Wetland plant materials shall be kept wet at all times, until installed.
2. Coordinate with Engineer for locations of all wetland and riparian plugs.
3. Holes for installing 10 T or small tubeling plants may be created with a dibble or sharpened dowel. Open holes just large enough to insert the entire plant and all the nursery soil at least one-half (1/2) inch below the native soil. The holes should not be formed more than one-half (1/2) inch deeper than the tubes. Once inserted, the hole shall be backfilled or tamped from the side with a mallet to secure the plant. If waterfowl grazing is a possibility, each plant (graminoids only) shall be trimmed to two (2) inches prior to installation and each plant shall be secured by an eight (8) inch landscape staple to discourage pulling by waterfowl.
4. In areas where wetland or riparian plugs are to be installed in riprap, the dibble or dowel may need to be probed into the soil riprap several times in order to find a location where the hole can be created deep enough in the voids of the riprap to accept the plug.

G. Maintenance Acceptance and Warranty

1. A final walk-through shall be performed at the completion of all planting operations under this contract.
2. At the time of final walk-through, the landscape contractor shall have the planting areas free of debris. Plant basins shall be in good repair, debris and litter shall be cleaned up,

and walkways, curbs, and roads shall be cleared of soil and debris. The inspection shall not occur until these conditions are met.

3. Engineer will review the work and identify a list of deficiencies in the form of a punch-list.
4. Engineer will give written notice of final acceptance when the work has been performed in compliance with the contract documents.
5. Correct deficiencies within the first ten (10) days of the final walk-through. Correct work in accordance with the contract documents at no cost to the owner.
6. Final acceptance shall not be given until all deficiencies are corrected. The landscape contractor shall maintain the site and all plantings until final acceptance.
7. Vandalism: The Contractor shall note that the project is in an open space area and that vandalism may occur. The Contractor shall take reasonable measures to protect plantings from vandalism until final acceptance and shall repair damaged work caused by vandalism.

SECTION 910 - EROSION AND SEDIMENT CONTROL

Section 910 is hereby added to the Standard Specifications and shall include the following:

910.1 GENERAL

910.1.1 Scope of Work:

- A. This work shall consist of temporary measures needed to control erosion and water pollution. These temporary measures shall include, but not be limited to, berms, dikes, coffer dams, sediment basins, fiber mats, wattles, netting, gravel, mulches, grasses, slope drains and other erosion control devices or methods. These temporary measures shall be installed at the locations where needed to control erosion and water pollution during the construction of the project, consistent with the **City** Stormwater Criteria Manual (SCM) requirements, and as directed by the **Engineer**, and as shown on the Drawings.
- B. The Erosion Control Plan presented in the Drawings serves as a concept plan and base sheets for erosion and sediment control during construction. **Contractor** has the ultimate responsibility for providing adequate sediment and erosion control and water quality throughout the duration of the project. Therefore, the **Contractor** shall develop a plan, consistent with the **City** SCM requirements, and provide whatever measures are needed to achieve the required protection of areas that will be disturbed during the contractor's work on the project consistent with the Contractor's work plan for the project. **Contractor** shall include in his bid price for erosion and sediment control all items that may be needed to control erosion, sediment and water pollution.

910.1.2 Submittals: The erosion and sediment control facilities shown on the Drawings are conceptual, and the **Contractor** shall update the drawings prior to the start of work and develop a detailed Storm Water Management Plan (SWMP), consistent with the **Contractor's plan to accomplish the work**, a continuously updated copy of which shall be retained on the site. The **Contractor** shall submit an application to the **State**, and submit the SWMP to the **State** at their request. The **Contractor** shall obtain a Storm Water Construction Permit from the State. The **Contractor** shall also apply for a **City** Grading and Erosion Control (GEC) Permit and create and submit a **City** Construction and

Stormwater Management Plan (referred to as the C-SWMP by the **City**). The C-SWMP shall indicate that it has been prepared for the **City** and the **State**. **Permits/approvals for both the City and the State must be obtained prior to construction.** The **Contractor** is responsible for implementing the C-SWMP and compliance with the conditions of the Storm Water Construction Permit and GEC permit. The **State** or the **Engineer** may direct the **Contractor** to modify the C-SWMP during construction as conditions warrant. The **Contractor** shall note changes on the C-SWMP immediately as it must reflect current site conditions.

910.1.3 Materials:

A. Materials may include hay bales, straw, fiber mats, fiber netting, wood cellulose, fiber fabric, manufactured waddles, gravel, riprap, pre-cast concrete barriers, and other suitable materials, and shall be reasonably clean, free of deleterious materials, and certified weed free. All materials shall be submitted to the **Engineer** for approval prior to installation.

B. Temporary grass cover (if required) shall be a quick growing species suitable to the area, which will provide temporary cover and will not later compete with the grasses sown for permanent cover. All grass seed shall be approved by the **Owner** prior to installation.

C. Fertilizer and soil conditioners shall be approved by the **Owner** prior to installation.

D. Miscellaneous: All other material used by the Contractor for water diversion and erosion control shall be specified on a detailed working Erosion and Sediment Control Plan to be completed by the Contractor and reviewed by the **Engineer** prior to starting work.

910.1.4 Construction Requirements: All materials for erosion and sediment control shall be installed in accordance with these Specifications. To the extent possible, movement of construction equipment within the flowing portions of waterways should be minimized. The Contractor shall divert flows so construction equipment, materials, and earthwork are not exposed to flow to the extent practical.

The erosion and sediment control facilities shall be installed prior to construction and shall remain in place throughout. The Contractor will be required to clean sediment from upstream sediment traps and provide other maintenance as required to the erosion and sediment control facilities during construction.

910.2 PERMITS AND COMPLIANCE

A. **Contractor** must apply for and obtain a Construction Dewatering Permit (Colorado Wastewater Discharge Permit), a Stormwater Construction Permit from the Colorado Department of Health and shall obtain approval of an Erosion and Stormwater Quality Control Plan from the City of Colorado Springs. All costs for these permits shall be the responsibility of **Contractor**. These permits require that specific actions be performed at designated times. **Contractor** is legally obligated to comply with all terms and conditions of the permits including testing for effluent limitations if required by the terms of the permits.

CONTRACTOR shall allow the Colorado Department of Health or other representatives to enter the site to test for compliance with the permit. Non-compliance with the permit can result in stoppage of all work.

In addition to permit requirements, **Engineer** shall also monitor **Contractor's** erosion control and work methods. If the overall function and intent of erosion control is not being met, then **Engineer** shall require **Contractor** to provide additional measures as required to obtain the desired results. Costs for any additional erosion control measures shall be the responsibility of **Contractor**, since he has the ultimate responsibility for providing adequate erosion control and water quality for the duration of the project.

910.3 STABILIZATION OF DISTURBED AREAS

- A. Temporary sediment control measures shall be established within 5 days from time of exposure/disturbance. Permanent erosion protection measures shall be established within 21 days after final grading of areas.

910.4 PROTECTION OF ADJACENT PROPERTIES

- A. Properties adjacent to the site of a land disturbance shall be protected from sediment deposition. In addition to the erosion control measures required on the Drawings, perimeter controls may be required if damage to adjacent properties is likely. Perimeter controls include, but are not limited to, a vegetated buffer strip around the lower perimeter of the land disturbance, sediment barriers such as straw bales and silt fences; sediment basins; or a combination of such measures. Vegetated buffer strips may be used only where runoff in sheet flow is expected and should be at least 20 feet in width.

910.5 TIMING AND STABILIZATION OF SEDIMENT AND EROSION CONTROL MEASURES

- A. Sediment barriers, perimeter dikes, and other measures intended to either trap sediment or prevent runoff from flowing over disturbed areas must be constructed as a first step in grading and be made functional before land disturbance takes place. Earthen structures such as dams, dikes, and diversions must be stabilized within 5 days of installation. Stormwater outlets must also be stabilized prior to any upstream land disturbing activities.

910.6 WORKING IN OR CROSSING WATERCOURSES

- A. Construction vehicles should be kept out of watercourses to the extent possible. Where in-channel work is necessary, precautions must be taken to stabilize the work area during construction to minimize erosion. The channel (including bed and banks) must always be re-stabilized immediately after in-channel work is completed.
- B. When work must occur in a live (wet) watercourse, extra care must be exercised by the Contractor to avoid contamination of the water from petroleum products and other pollutants and to minimize the movement of sediment downstream.

910.7 CONSTRUCTION ACCESS ROUTES

- A. Wherever construction vehicles enter or leave a construction site, a Stabilized Construction Entrance is required. Where sediment is transported onto a public road or parking lot surface, the pavement shall be cleaned thoroughly at the end of each day. Sediment shall be removed from roads or parking lots by shoveling or sweeping and be transported to a sediment-controlled disposal area. Street washing shall be allowed only after sediment is removed in this manner.

910.8 DISPOSITION OF TEMPORARY MEASURES

- A. All temporary erosion and sediment control measures shall be disposed of within 30 days after final site stabilization is achieved or after the temporary measures are no longer needed as determined by **Engineer**. Trapped sediment and other disturbed soil areas resulting from the disposition of temporary measures shall be permanently stabilized to prevent further erosion.

910.9 MAINTENANCE

- A. All temporary and permanent erosion and sediment control practices must be maintained and repaired as needed to assure continued performance of their intended function.

SECTION 920 - WATER CONTROL AND DEWATERING

Section 920 is hereby added to the Standard Specifications and shall include the following:

920.1 General

920.1.01 Scope of Work:

The work of this section consists of controlling groundwater, channel low flows, and higher storm flows during construction. Contractor is cautioned that the work involves construction in and around drainage channels, local rivers, and areas of local drainage. These areas are subject to frequent periodic inundation.

920.1.02 Materials:

Onsite materials may be used within the limits of construction to construct temporary dams and berms. Other materials such as plastic sheeting, sandbags, pre-cast concrete barriers, riprap and storm sewer pipe, and pumps may also be used if desired by the **Contractor**.

920.1.03 Submittals

The **Contractor** is required to submit a detailed Water Control and Dewatering Plan for review prior to installing any components of the plan. At a minimum, the Water Control and Dewatering Plan shall include:

- A. Descriptions of proposed groundwater and surface water control facilities including but not limited to, equipment, methods, standby equipment and power supply, means of measuring inflow to excavations, pollution control facilities, discharge locations to be utilized, and types of construction, such as: temporary well points, coffer dams, channels, or other flow diversion schemes.
- B. Drawings showing locations, dimensions, and relationship of elements of each system.
- C. Design calculations demonstrating adequacy of proposed dewatering systems and components.
- D. If system is modified during installation or operation, revise or amend and resubmit Water Control and Dewatering Plan.

920.1.04 Construction Requirements:

- A. **General:** For all excavation, the **Contractor** shall provide suitable equipment and labor to remove water and ice and keep the excavation dewatered so that construction can be completed in dry conditions where required by the Drawings and Specifications. Continuously control water during course of construction, including weekends and holidays and during periods of work stoppages, and provide adequate backup systems to maintain control of water.

Water control shall be accomplished such that no damage is done to adjacent channel banks or structures. The **Contractor** is responsible for investigating and becoming familiar with all site conditions that may affect the work including surface water; level of groundwater and the time of year the work is to be done. All excavations made as part of dewatering operations shall be backfilled with the same type material as was removed and compacted to a minimum of 95% of the maximum dry density modified proctor (ASTM 1557) except where replacement by other materials and/or methods are required.

By submitting a BID, CONTRACTOR acknowledges that CONTRACTOR has investigated the risk arising from surface water and groundwater, and has prepared his BID accordingly, and assumes all of said risk.

At no time during construction shall CONTRACTOR affect existing surface or subsurface drainage patterns on adjacent property. Any damage to adjacent property resulting from CONTRACTOR's alteration of surface or subsurface drainage patterns shall be repaired by CONTRACTOR at no additional cost to OWNER.

Pumps and generators used for dewatering and water control shall be quiet equipment enclosed in sound deadening devices. Contractor shall remove all temporary water control facilities when they are no longer needed or at the completion of the PROJECT.

B. *Surface Water Control:* Surface water control generally falls into the following categories:

1. Normal low flows along Sand Creek
2. Storm/flood flows along Sand Creek
3. Flows from pipe outfalls and
4. Local surface flows

The **Contractor** shall coordinate, evaluate, design, construct, and maintain temporary water control systems. These systems shall not worsen flooding, alter major flow paths, or worsen flow characteristics during construction. The **Contractor** is responsible to ensure that any such worsening of flooding does not occur.

At a minimum, the **Contractor** will be responsible for diverting the quantity of surface flow around the construction area so that the excavation and the placement of embankment, riprap and bedding material can remain free of surface water and ice for the time it takes to install these materials, and the time required for curing of any concrete or grout. The **Contractor** is cautioned that the minimum quantity of water to be diverted is for erosion control and construction purposes and not for general protection of the construction site. ***It shall be the Contractor's responsibility to determine the quantity of water which shall be diverted to protect all work from damage caused by stormwater. The Contractor will be responsible for all repairs required due to flood damage.***

The Contractor shall, at all times, maintain a flow path for Sand Creek Channel flow.

Temporary structures such as berms, sandbags, pre-cast concrete barriers, etc. may be permitted for the control of channel flow, as long as such measures are not a major obstruction to flood flows, do not worsen flooding, or alter historic flow routes. Existing trees and vegetation should be preserved. The Contractor shall conduct the operation in such a manner that storm waters may proceed uninterrupted along the drainage courses. Any damage done during storm flows to temporary or partially completed structures, or resulting from the Contractor's operations, shall be repaired by the Contractor at the Contractor's expense.

C. *Groundwater Control:* The Contractor shall install adequate measures to maintain the level of groundwater below the foundation subgrade elevation and maintain sufficient bearing capacity for structures, pipelines, earthwork, and rock work. Groundwater levels may fluctuate. Such measures may include, but are not limited to, installation of perimeter subdrains, pumping from drilled holes or pumping from sumps excavated below the subgrade elevation. The foundation bearing surfaces are to be kept dewatered and stable until the structures or other types of work are complete and backfilled. Disturbance of foundation subgrade by Contractor operations shall not be considered as originally unsuitable foundation subgrade and shall be repaired at Contractor's cost. The Contractor shall coordinate ground water control measures with surface water diversions since the effectiveness of ground water control will depend on the amount of surface water infiltration allowed by the diversion system.

Contractor shall dispose of groundwater as follows:

- A. Obtain discharge permit for water disposal from authorities having jurisdiction.
- B. Treat water collected by dewatering operations, as required by regulatory agencies, prior to discharge.
- C. Discharge water as required by discharge permit and in manner that will not cause erosion or flooding, or otherwise damage existing facilities, completed Work, or adjacent property.
- D. Remove solids from treatment facilities and perform other maintenance of treatment facilities as necessary to maintain their efficiency.

SECTION 925 – CLEARING AND GRUBBING

Section 925 is hereby added to the Standard Specifications and shall include the following:

925.01 Description

This work consists of clearing, grubbing, removing, and disposing of all vegetation, debris, and materials as needed to construct the proposed improvements as shown on the Drawings and as required by the Work. Vegetation and objects designated to remain shall be preserved free from injury or defacement.

925.02 Construction Requirements

All trees, shrubs, grass, weeds and debris located within approximate work limits as shown on the plans and details that must be removed to accomplish the work shall be removed and properly disposed of offsite, unless otherwise specified on the plans or by the owner. Removal of any vegetation shall be reviewed and approved by the Owner prior to removal. Trees and significant shrubs to be removed shall be marked by the contractor and approved by the owner prior to removal. Any object including trees, shrubs, or plants not designated for removal by the **Owner**, that are damaged shall be repaired or replaced as directed by the **Owner**, at the **Contractor's** expense.

Except in areas to be excavated, all holes resulting from the removal of obstructions shall be backfilled with suitable material and compacted in accordance with the Standard Specifications.

Except as otherwise noted in the plans and special provisions, all cleared timber shall be moved from the project and shall become the property of the **Contractor**. Branches on trees or shrubs shall be removed as directed. All trimming shall be done in accordance with good tree surgery practices as recommended by **City Parks and Recreation Department**.

SECTION 950 - CONSTRUCTION SURVEYING

Section 950 is hereby added to the Standard Specifications and shall include the following:

950.01 General

- A. Surveying: It shall be the responsibility of the **Contractor** to provide construction staking for as needed to control horizontal and vertical locations of the proposed work items including all offset lines necessary for construction.
- B. All construction surveying provided by the **Contractor** shall be completed under the Supervision of a Colorado Registered Land Surveyor.
- C. The construction plans for the project provide the elevations and descriptions of permanent and temporary project monuments. The Contractor shall check all control points provided by the Engineer and verify and document their accuracy, prior to using them for construction surveying.
- D. Supervision: The Contractor shall have supervision, knowledge of the project requirements and proper installation, and construction procedures, available in the field at all times that work is progressing.



SCHEDULE G – DRAWINGS

Will follow this page.

THE CITY OF COLORADO SPRINGS, COLORADO, IS AN INSTRUMENTALITY OF THE STATE OF COLORADO. THE CITY ENGINEER HAS REVIEWED THESE PLANS AND HAS DETERMINED THAT THEY COMPLY WITH THE CITY OF COLORADO ENGINEERING CODES AND STANDARDS. THE CITY ENGINEER'S REVIEW IS LIMITED TO THE TECHNICAL ASPECTS OF THE PLANS AND DOES NOT CONSTITUTE A GUARANTEE OF THE ACCURACY OR COMPLETENESS OF THE INFORMATION PROVIDED HEREON. THE CITY ENGINEER'S REVIEW IS LIMITED TO THE TECHNICAL ASPECTS OF THE PLANS AND DOES NOT CONSTITUTE A GUARANTEE OF THE ACCURACY OR COMPLETENESS OF THE INFORMATION PROVIDED HEREON.

APPROVED BY: _____

CITY OF COLORADO SPRINGS _____ DATE
 ENGINEERING DIVISION

CITY OF COLORADO SPRINGS _____ DATE
 STORMWATER ENTERPRISE

COLORADO SPRINGS _____ DATE
 PARKS AND RECREATION DEPARTMENT

COLORADO SPRINGS UTILITIES _____ DATE
 WATER RESOURCES - WATER

COLORADO SPRINGS UTILITIES _____ DATE
 WATER RESOURCES - WASTEWATER

COLORADO SPRINGS UTILITIES _____ DATE
 ELECTRIC DEPARTMENT

COLORADO SPRINGS UTILITIES _____ DATE
 GAS DEPARTMENT

SAND CREEK DETENTION POND NO. 2 RESTORATION FINAL DESIGN

PREPARED FOR:
CITY OF COLORADO SPRINGS, COLORADO
STORMWATER ENTERPRISE
PROJECT NO. R010097

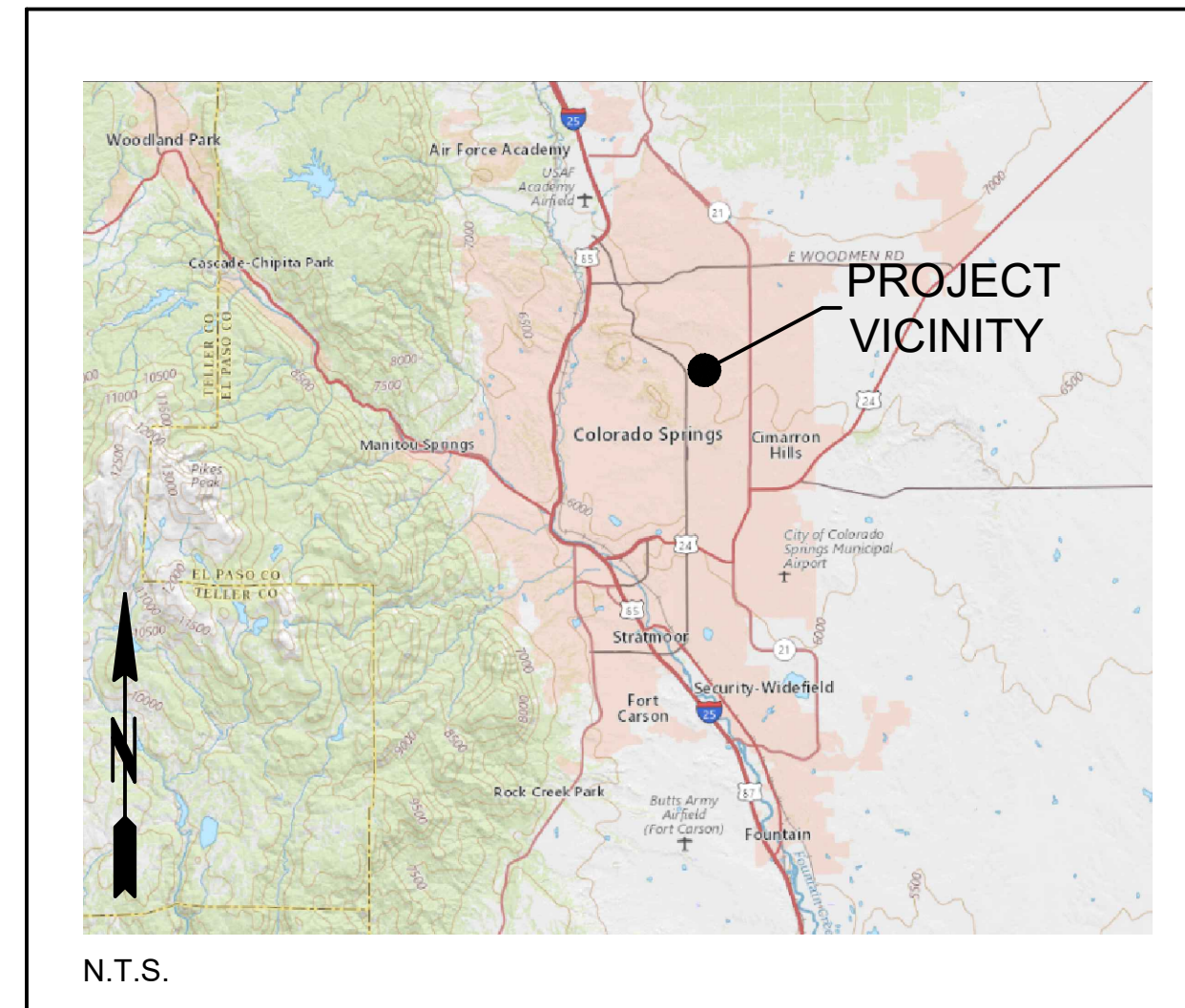

VICINITY MAP

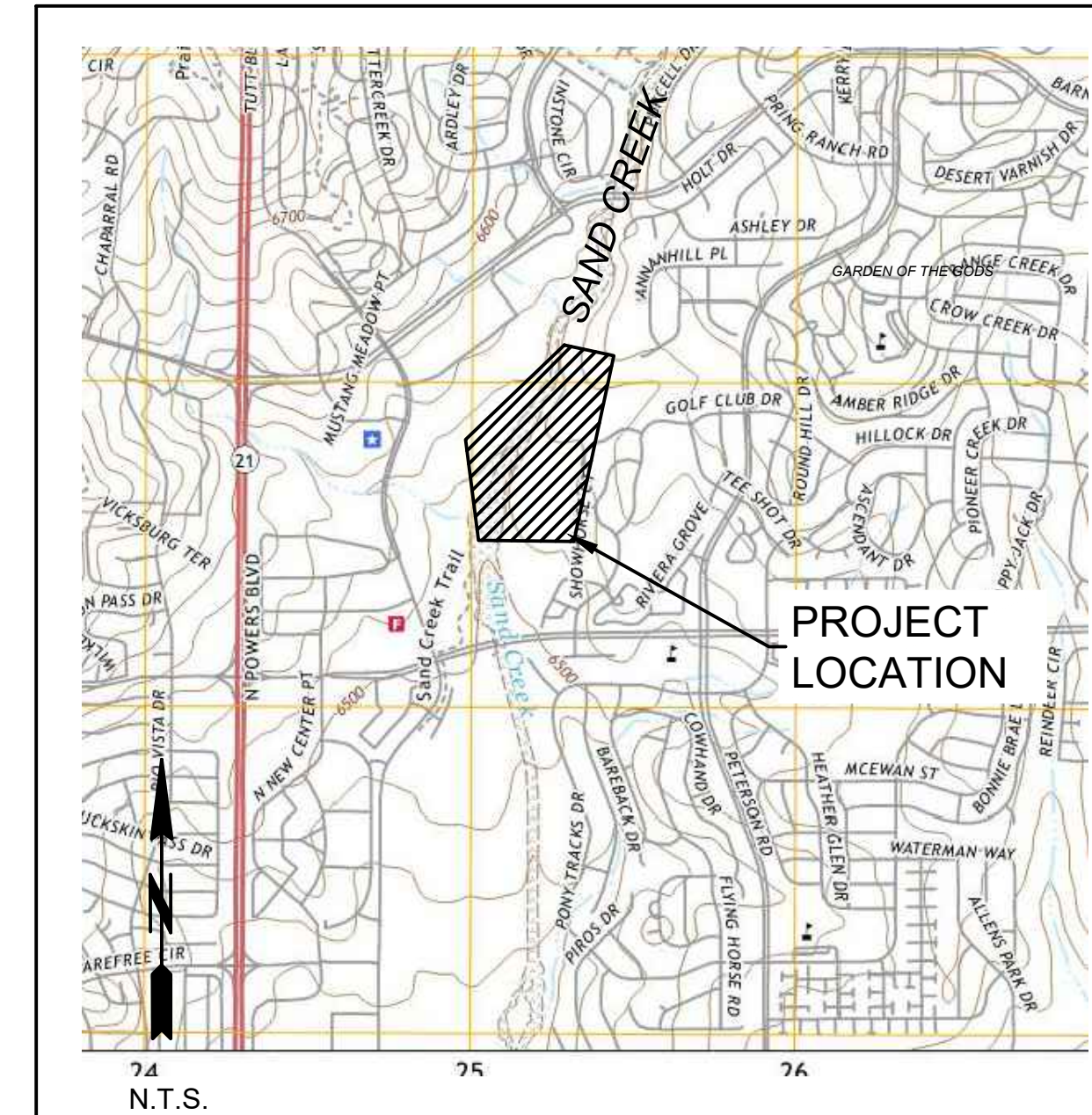

LOCATION MAP

"I HEREBY CERTIFY THAT THE DRAINAGE IMPROVEMENTS FOR SAND CREEK DETENTION POND NO. 2 SHALL BE CONSTRUCTED ACCORDING TO THE DESIGN PRESENTED IN THESE PLANS. I FURTHER UNDERSTAND THAT FIELD CHANGES MUST BE REVIEWED BY THE CITY REVIEW ENGINEER TO ENSURE CONFORMANCE WITH THE ORIGINAL DESIGN INTENT. I AM EMPLOYED BY AND PERFORM ENGINEERING SERVICES SOLELY FOR THE CITY OF COLORADO SPRINGS, AND THEREFORE AM EXEMPT FOR COLORADO REVISED STATUTE TITLE 12, ARTICLE 25, PART 1 ACCORDING TO § 12-25-103(1) C.R.S.

Beau Thompson, PE

NAME OF CITY PROJECT MANAGER _____ DATE
 9-19-24
 AUTHORIZED SIGNATURE _____ DATE



AGENCY REFERRALS

CITY OF COLORADO SPRINGS
 STORMWATER ENTERPRISE
 30 S. NEVADA AVE., SUITE 401
 COLORADO SPRINGS, CO. 80903
 (719) 385-5980
 CONTACT: BEAU THOMPSON, PE

COLORADO SPRINGS UTILITIES
 111 S. CASCADE AVENUE
 COLORADO SPRINGS, CO 80903
 (719) 448-4800
 CONTACT:

ENGINEER'S STATEMENT:

THIS PERMANENT CONTROL MEASURE (PCM) PLAN WAS PREPARED UNDER MY DIRECTION AND SUPERVISION, WAS DESIGNED IN ACCORDANCE WITH THE CITY OF COLORADO SPRINGS DRAINAGE CRITERIA MANUAL (MAY 2014), AND IS CORRECT TO THE BEST OF MY KNOWLEDGE AND BELIEF. I ACCEPT RESPONSIBILITY FOR ANY LIABILITY CAUSED BY ANY NEGLIGENT ACTS, ERROR OR OMISSIONS ON MY PART IN PREPARATION OF THIS PCM PLAN.

SIGNATURE: *Walter C. Pennington*

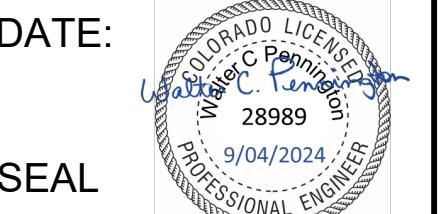

PRINTED NAME: WALTER PENNINGTON, PE
 EMAIL ADDRESS: WALT.PENNINGTON@MERRICK.COM

CITY OF COLORADO SPRINGS STATEMENT:
 FILED IN ACCORDANCE WITH SECTION 7.7.906 OF THE CODE OF THE CITY OF COLORADO SPRINGS, 2001, AS AMENDED.

David M. Mustain _____ DATE
 9/10/2024
 FOR CITY ENGINEER

CONDITIONS:

CIVIL ENGINEER	LANDSCAPE ARCHITECT	STRUCTURAL ENGINEER	GEOTECHNICAL ENGINEER	SURVEYOR	ENVIRONMENTAL
MERRICK & COMPANY 2480 W. 26TH AVENUE, SUITE B225 DENVER, CO 80211 (303) 964-3333 CONTACT: WALTER PENNINGTON, P.E.	THE ARCHITERRA GROUP 5881 SOUTH DEFRAME ST. LITTLETON, COLORADO 80127 (303) 948-0766 CONTACT: MARK TAYLOR, PLA, ASLA	SM&R STRUCTURAL ENGINEERS INC. 215 S. WADSWORTH BLVD, SUITE 320 LAKEWOOD, CO 80226 (303) 274-8656 CONTACT: DAVID BLANCHETTE, P.E.	VIVID ENGINEERING GROUP INC. 1053 ELKTON DRIVE COLORADO SPRINGS, CO 80907 (719) 896-4356 CONTACT: BRYSEN MUSTAIN	MERRICK & COMPANY 5970 GREENWOOD PLAZA BLVD GREENWOOD VILLAGE, CO 80111 (303) 751-0741 CONTACT: TODD BEERS, P.L.S.	CORVUS ENVIRONMENTAL CONSULTING, LLC. 6429 S. MARION PLACE CENTENNIAL, CO 80121 (303) 250-2118 CONTACT: TIM DEMASTERS



CITY OF COLORADO SPRINGS
30 S. NEVADA AVE., SUITE 401
COLORADO SPRINGS, CO 80903
(719) 385-5980

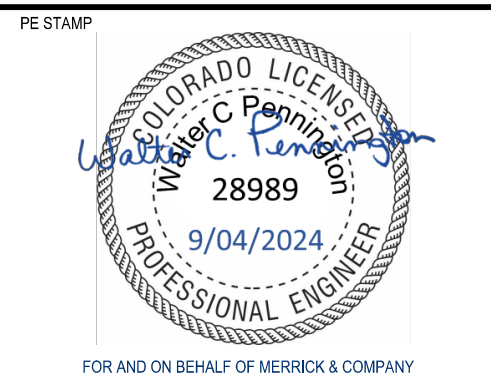

TITLE
SAND CREEK DETENTION POND NO. 2
 COVER SHEET

JOB NUMBER: 65420975
 DATE: AUGUST 2024
 DWG: ID-101
 SHEET 1 of 51

SHEET INDEX		
DWG	SHEET TITLE	SHEET
ID-101	COVER SHEET	1
ID-202	GENERAL NOTES AND LEGEND	2
C-101	SUBSURFACE UTILITY ENGINEERING PLAN	3
C-102	PROJECT CONTROLS (SOUTH)	4
C-103	PROJECT CONTROLS (NORTH)	5
C-201	EXISTING CONDITIONS, PROPERTY OWNERSHIP, AND DEMOLITION PLAN	6
C-301	CONSTRUCTION ACCESS, STAGING, AND GENERAL TRAFFIC CONTROL	7
C-401	OVERALL GRADING PLAN AND KEY MAP	8
C-402	GRADING PLAN (SOUTH)	9
C-403	GRADING PLAN (NORTH)	10
C-404	POND SECTIONS	11
C-405	POND SECTIONS	12
C-501	SAND CREEK CHANNEL PLAN AND PROFILE 0+00 TO 7+50	13
C-502	SAND CREEK CHANNEL PLAN AND PROFILE 7+50 TO 15+45	14
C-503	TUTT OUTFALL PLAN AND PROFILE	15
C-504	SPRINGS RANCH WETLAND CHANNEL PLAN AND PROFILE	16
C-505	SPRINGS RANCH PLAN AND PROFILE	17
C-506	BARNES WQ POND OUTFALL PIPE AND CHANNEL PLAN AND PROFILE	18
C-507	POND PERIMETER ACCESS ROAD PROFILE	19
C-508	OUTLET STRUCTURE AND TUTT OUTFALL ACCESS ROAD PROFILES	20
C-601	POND OUTLET STRUCTURE	21
C-602	RIPRAP DETAILS	22
C-603	CIVIL DETAILS	23
C-604	CIVIL DETAILS	24
L-100	SEEDING AND WETLAND PLUGS PLAN	25
L-101	PLANTING PLAN	26
L-102	PLANTING PLAN	27
L-201	PLANTING DETAILS	28
L-301	OUTFALL STRUCTURE AESTHETIC DETAILS	29
L-302	OUTFALL STRUCTURE AESTHETIC DETAILS	30
L-303	OUTFALL STRUCTURE AESTHETIC DETAILS	31
L-304	TUTT OUTFALL AND RETAININGWALL AESTHETIC DETAILS	32
S-100	LEGEND, ABBREVIATIONS, AND GENERAL NOTES SHEET 1	33
S-101	LEGEND, ABBREVIATIONS, AND GENERAL NOTES SHEET 2	34
S-102	POND 2 OUTLET ISOMETRIC VIEW	35
S-103	POND 2 OUTLET OUTLINE PLAN	36
S-104	POND 2 OUTLET SECTIONS	37
S-105	POND 2 OUTLET REINFORCEMENT PLAN	38
S-106	POND 2 OUTLET REINFORCEMENT SECTIONS	39
S-107	POND 2 OUTLET REINFORCEMENT SECTIONS	40
S-108	POND 2 OUTLET REINFORCEMENT SECTIONS	41
S-109	POND 2 OUTLET DOWEL ANCHOR PLAN AND DETAILS	42
S-110	POND 2 OUTLET UNDER DRAIN PLAN AND DETAILS	43
S-111	POND 2 OUTLET CONCRETE STANDARD DETAILS	44
S-112	TUTT WALL ISOMETRIC	45
S-113	TUTT WALL OUTLINE PLAN AND ELEVATIONS	46
S-114	TUTT WALL REINFORCEMENT PLAN AND SECTION	47
S-115	TUTT WALL REINFORCEMENT PLAN AND SECTION	48
S-116	TUTT WALL REINFORCEMENT PLAN AND SECTION	49
S-117	TUTT WALL REINFORCEMENT PLAN AND SECTION	50
S-118	POND 2 OUTLET & TUTT RETAINING WALL STEEL HANDRAIL DETAILS	51

THE CITY OF COLORADO SPRINGS IS PROVIDING THESE PLANS AS A SERVICE TO THE CITY OF COLORADO SPRINGS. MERRICK & COMPANY, INC. IS THE ENGINEER OF RECORD FOR THIS PROJECT. IT IS THE USER'S RESPONSIBILITY TO VERIFY THE ACCURACY OF THE INFORMATION PROVIDED ON THESE PLANS. MERRICK & COMPANY, INC. IS NOT RESPONSIBLE FOR ANY DAMAGE OR INJURY TO PERSONS OR PROPERTY CAUSED BY THE USE OF THESE PLANS. THE USER SHALL BE RESPONSIBLE FOR OBTAINING ALL NECESSARY PERMITS AND APPROVALS FROM THE CITY OF COLORADO SPRINGS AND ANY OTHER AGENCIES. THE USER SHALL BE RESPONSIBLE FOR OBTAINING ALL NECESSARY PERMITS AND APPROVALS FROM THE CITY OF COLORADO SPRINGS AND ANY OTHER AGENCIES.

File Location: Q:\Denver_North\Projects\City of Colorado Springs\Sand Creek Pond No. 2\CAD\CDS\0975 - Cover.dwg Plot Date: 8/26/2024 4:23 PM Last Saved By: TMM.MCMULLEN

GENERAL NOTES

- ALL CONSTRUCTION SHALL BE IN ACCORDANCE WITH THE PROJECT SPECIFICATIONS, THE CITY OF COLORADO SPRINGS STANDARD SPECIFICATIONS, AND CITY OF COLORADO SPRINGS STORMWATER ENTERPRISE DRAINAGE CRITERIA MANUAL AND STORMWATER CONSTRUCTION MANUAL, THE UNLESS OTHERWISE NOTED ON THE DRAWINGS OR IN THE CONTRACT DOCUMENTS.
- DIMENSIONS AND NOTATIONS SUPERSEDE SCALE OF THE DRAWINGS.
- MONUMENTS AND PROJECT SURVEY CONTROL INFORMATION ARE INCLUDED IN THESE DRAWINGS. CONTRACTOR SHALL BE RESPONSIBLE FOR REPLACING OR FIXING ANY MONUMENTS DISTURBED BY THE CONTRACTOR.
- THE CONTRACTOR SHALL BE RESPONSIBLE FOR THE ACCEPTANCE, CONVEYANCE, AND CONTROL OF ALL SURFACE AND SUBSURFACE WATER FLOWS IN AND ENTERING SAND CREEK DRAINAGE FACILITIES AFFECTED BY THIS PROJECT. THE CONTRACTOR SHALL BE RESPONSIBLE FOR OPERATIONS OR ANY OTHER ACCEPTABLE MEANS TO PREVENT POLLUTION OF SAND CREEK IN ACCORDANCE WITH THE COLORADO DEPARTMENT OF PUBLIC HEALTH AND ENVIRONMENT PERMIT REQUIREMENTS. THE CONTRACTOR SHALL SUBMIT A WATER MANAGEMENT PLAN AND CANNOT BEGIN CONSTRUCTION UNTIL THE PLAN IS APPROVED BY THE OWNER. THE CONTRACTOR SHALL BE RESPONSIBLE FOR ALL DAMAGE INCLUDING DAMAGE TO STRUCTURES, LOSS OF TOPSOIL, AND LOSS OF SEED CAUSED BY FLOWS UNTIL THE PROJECT IS ACCEPTED BY THE OWNER. ALL WORK SHALL BE DONE IN A DRY CONDITION.
- UNDERGROUND UTILITIES IN THE AREA OF CONSTRUCTION WERE LOCATED FROM FIELD INVESTIGATION AND THE AVAILABLE UTILITY RECORDS. THE CONTRACTOR SHALL ASSUME FULL RESPONSIBILITY FOR THE LOCATION AND PROTECTION OF ANY UTILITIES AFFECTED BY THE EXECUTION OF THIS CONTRACT. THE CONTRACTOR SHALL BE RESPONSIBLE FOR CONTACTING 811 CENTRAL LOCATES AND AGENCIES AND FOR THE COORDINATION OF ALL WORK IN THE PROXIMITY OF THE UTILITIES.
- THE CONTRACTOR SHALL NOTE ALL UTILITIES MAY NOT APPEAR ON THESE PLANS AND THE POTENTIAL CONFLICT WITH UTILITIES SHALL BE CONSIDERED IN THE PREPARATION OF COST ESTIMATES AND BIDS.
- THE CONTRACTOR SHALL CONTACT ALL UTILITY OWNERS FOR INSPECTION WHEN WORK IS SCHEDULED ADJACENT TO THE UTILITIES. THE CONTRACTOR IS RESPONSIBLE FOR PROTECTING AFFECTED UTILITIES IN ACCORDANCE WITH THE PLANS, SPECIFICATIONS, AND THE REQUIREMENTS OF THE UTILITY OWNER. THE CONTRACTOR SHALL BE RESPONSIBLE FOR ANY DAMAGE AND COSTS ASSOCIATED WITH INTERRUPTED OR LOST SERVICE DUE TO DAMAGE TO THESE FACILITIES AND SHALL HOLD THE OWNER AND THE OWNER'S REPRESENTATIVES HARMLESS FOR DAMAGE ARISING FROM FAILURE TO PROTECT UTILITIES. IT SHALL BE THE RESPONSIBILITY OF THE CONTRACTOR TO SCHEDULE UTILITY ADJUSTMENTS TO ELIMINATE CONFLICT WITH PROGRESS OF WORK.
- ALL MATERIALS AND WORKMANSHIP SHALL BE SUBJECT TO INSPECTION BY THE OWNER. THE OWNER RESERVES THE RIGHT TO ACCEPT OR REJECT ANY SUCH MATERIALS AND WORKMANSHIP THAT DOES NOT CONFORM TO THE STANDARDS AND SPECIFICATIONS SHOWN IN THE CONTRACT DOCUMENTS.
- THE CONTRACTOR SHALL HAVE ONE (1) SIGNED COPY OF THE APPROVED PLANS, ONE (1) COPY OF THE APPROPRIATE STANDARDS AND SPECIFICATIONS, AND A COPY OF ANY PERMITS NEEDED AT THE JOB SITE AT ALL TIMES.
- THE CONTRACTOR IS RESPONSIBLE FOR ANY AND ALL PERMITS, LICENSE FEES, AND BONDS THAT ARE NECESSARY TO COMPLETE THE CONSTRUCTION OF THIS PROJECT. PERMITS REQUIRED FOR THIS PROJECT INCLUDE, BUT ARE NOT LIMITED TO: CITY GRADING, EROSION AND SEDIMENT QUALITY CONTROL PERMIT, STATE OF COLORADO DEPARTMENT OF PUBLIC HEALTH AND ENVIRONMENT STORMWATER MANAGEMENT PERMITS, DEWATERING AND TRAFFIC CONTROL/ACCESS PERMITS, AND EL PASO COUNTY DUST PERMIT.
- THE CONTRACTOR IS REQUIRED TO OBTAIN ALL NECESSARY PERMITS. FOR CITY PERMITS THE CONTRACTOR SHALL USE ACCELA ONLINE PERMIT SYSTEM.
- A PLAN FOR TRAFFIC CONTROL DURING CONSTRUCTION SHALL BE SUBMITTED TO THE CITY FOR APPROVAL WITH THE PERMIT APPLICATION.
- PRIOR TO COMMENCING CONSTRUCTION ACTIVITIES THE CONTRACTOR SHALL MEET WITH THE OWNER'S REPRESENTATIVE AND RECORD EXISTING CONDITIONS OF THE SITE AND ADJACENT PROPERTY.
- THE CONTRACTOR SHALL REFER TO THE CONTRACT SPECIFICATIONS FOR DESCRIPTION OF MATERIALS REFERRED TO BY SIZE, CLASS, TYPE, DESCRIPTION, OR OTHERWISE SPECIFIED ON THE DRAWINGS.
- THE CONTRACTOR IS RESPONSIBLE FOR SAVING AND PROTECTING ALL EXISTING TREES AND VEGETATION WHERE REMOVAL FOR CONSTRUCTION IS NOT MANDATORY, ALL TREES TO BE REMOVED SHALL BE CONFIRMED BY THE OWNER PRIOR TO REMOVAL. TREES APPROVED FOR REMOVAL SHALL BE REMOVED BY A LICENSED ARBORIST AND STUMPS GROUND DOWN BELOW FINISHED GRADE IF ROOTS ARE NOT REMOVED BY EXCAVATION ACTIVITIES.
- EXISTING TREES OR SHRUBS, NOT SHOWN ON THE DRAWINGS, SHALL BE COORDINATED WITH THE CITY FOR PROTECTION OR REMOVAL.
- UNAUTHORIZED CHANGES AND USES: THE ENGINEER WHO PREPARED THESE PLANS WILL NOT

- BE RESPONSIBLE OR LIABLE FOR UNAUTHORIZED CHANGES TO OR USES OF THESE PLANS. ALL CHANGES TO THE PLANS AND SPECIFICATIONS MUST BE IN WRITING AND MUST BE APPROVED BY THE OWNER AND THE PREPARER OF THESE PLANS.
- THE CONTRACTOR SHALL NOTIFY THE OWNERS REPRESENTATIVE IMMEDIATELY OF ANY FIELD CONDITION NOT CONSISTENT WITH THE CONSTRUCTION DOCUMENTS.
- THE CONTRACTOR SHALL PERFORM ALL WORK WITHIN THE WORK LIMITS AS SHOWN ON THE DRAWINGS AND DISCUSSED IN THE CONTRACT DRAWINGS. IF THE CONTRACTOR DAMAGES ANY EXISTING SITE OR PUBLIC AMENITIES (PAVEMENTS, CURBS, CURB AND GUTTER, SOD, TREES, FENCES, UTILITIES, ETC) OUTSIDE OR WITHIN THE EASEMENTS OR CONSTRUCTION LIMITS, THEY SHALL REMOVE AND REPAIR SUCH TO THE SATISFACTION OF THE INDIVIDUAL PROPERTY OWNERS AT THE CONTRACTOR'S EXPENSE.
- ITEMS TO BE REMOVED SHALL BECOME THE PROPERTY OF THE CONTRACTOR, UNLESS NOTED OTHERWISE IN THE PLANS.
- THE CONTRACTOR SHALL BE RESPONSIBLE FOR PROVIDING THE TEMPORARY EROSION CONTROL MEASURES (WIND AND WATER) DURING THE FULL TERM OF CONSTRUCTION IN ACCORDANCE WITH THESE PLANS AND SPECIFICATIONS.
- ALL DISTURBED AREAS SHALL BE SEEDDED IN ACCORDANCE WITH THE PROJECT SPECIFICATIONS. EROSION CONTROL BLANKET SHALL BE INSTALLED ON ALL AREAS WITH SLOPES 3H TO 1V OR STEEPER.
- THE EXACT LIMITS OF THE CONTRACTOR'S PARKING AND STAGING AREA FOR MATERIAL STOCKPILING, AND OFFICE TRAILERS, IF DIFFERENT THAN SHOWN ON THE PLANS, SHALL BE SUBMITTED BY THE CONTRACTOR FOR THE REVIEW AND THE APPROVAL OF THE OWNER'S REPRESENTATIVE.
- ALL REQUIRED UTILITIES FOR THE CONTRACTOR'S STAGING AREA SHALL BE ARRANGED BY THE CONTRACTOR DIRECTLY WITH THE APPROPRIATE UTILITY AGENCY. UTILITY ARRANGEMENTS SHALL BE SUBJECT TO THE APPROVAL OF THE CONTRACTOR TO ENCLOSE AND SET UP HIS OPERATIONAL AREA. ADDITIONALLY, THE CONTRACTOR SHALL RESTORE THE SITE TO ITS ORIGINAL CONDITION TO THE SATISFACTION OF THE OWNER'S REPRESENTATIVE UPON COMPLETION OF THE CONTRACT WORK.
- WASTE MATERIAL PRODUCED AS A RESULT OF THE CONTRACTOR'S OPERATIONS SHALL BE LEGALLY DISPOSED OF OFF THE PROJECT SITE OR AS DIRECTED BY THE OWNER'S REPRESENTATIVE AT THE CONTRACTOR'S EXPENSE.
- THE CONTRACTOR SHALL COMPLY WITH ALL LOCAL, STATE, AND FEDERAL LAWS AND REGULATIONS THAT ARE PERTINENT TO THIS WORK.
- THE CONTRACTOR SHALL BE RESPONSIBLE FOR CONTINUOUS CLEANUP OF ANY TRASH ON THE SITE OR ADJACENT PROPERTIES AND STREETS AS A RESULT OF CONSTRUCTION ACTIVITIES.
- ANY CONSTRUCTION DEBRIS OR MUD TRACKING ONTO THE PUBLIC RIGHT-OF-WAY, RESULTING FROM THE PROJECT, SHALL BE IMMEDIATELY REMOVED BY THE CONTRACTOR. THE CONTRACTOR SHALL IMMEDIATELY FIX ANY EXCAVATION, OR PAVEMENT FAILURE CAUSED BY THE PROJECT, AND SHALL PROPERLY BARRICADE THE SITE UNTIL CONSTRUCTION IS COMPLETE.
- THE CONTRACTOR SHALL BE SOLELY AND COMPLETELY RESPONSIBLE FOR THE CONDITIONS AT, AND ADJACENT TO THE JOB SITE, INCLUDING BUT NOT LIMITED TO TRENCH EXCAVATIONS AND SHORING, TRAFFIC CONTROL, SECURITY, AND SAFETY OF ALL PERSONS AND PROPERTY, DURING THE PERFORMANCE OF THE WORK. THIS REQUIREMENT SHALL APPLY CONTINUOUSLY, AND SHALL NOT BE LIMITED TO NORMAL WORKING HOURS. THE DUTY OF THE OWNER TO CONDUCT CONSTRUCTION REVIEW OF THE CONTRACTOR'S PERFORMANCE IS NOT INTENDED TO INCLUDE REVIEW OF THE ADEQUACY OF THE CONTRACTOR'S SAFETY MEASURES IN OR NEAR THE CONSTRUCTION SITE.
- THE CONTRACTOR SHALL BE RESPONSIBLE FOR ANY NEEDED DEWATERING OPERATIONS INCLUDING ANY REQUIRED PERMITS FOR DEWATERING OPERATIONS.
- ALL GRADES SHOWN ARE FINISHED GRADES, UNLESS OTHERWISE NOTED ON THE DRAWINGS.
- ALL SLOPES SHOWN ARE DIAGRAMMATIC AND SHALL BE ROUNDED AT TOP AND BOTTOM.
- THE CONTRACTOR SHALL BE RESPONSIBLE FOR PROVIDING THE CITY WITH A MARKED SET OF (REDLINES) CONSTRUCTION DRAWINGS SHOWING ALL CHANGES MADE DURING CONSTRUCTION.

SURVEY NOTES:
 SURVEY COMPLETED BY MERRICK & COMPANY IN FALL 2021 AND SUMMER 2022.
 VERTICAL DATUM: NAVD88
 HORIZONTAL DATUM: NAD83 STATE PLANE COLORADO CENTRAL ZONE,
 MODIFIED GROUND (COMBINED SCALE FACTOR = 0.99963449)

LEGEND

---	6515	---	EXISTING CONTOUR MAJOR
---	6501	---	EXISTING CONTOUR MINOR
---	6515	---	PROPOSED CONTOUR MAJOR
---	6501	---	PROPOSED CONTOUR MINOR
---	E	---	EXISTING ELECTRICAL
---	SS	---	EXISTING SANITARY SEWER
---	SS	---	ABANDONED SANITARY SEWER
---	ST	---	EXISTING STORM SEWER
---	WL	---	EXISTING WATER
---	G	---	EXISTING GAS
---	---	---	ALIGNMENT CENTERLINE
---	---	---	PROPOSED STORM SEWER
---	---	---	PROPERTY LINE
---	---	---	EASEMENT
---	---	---	PROJECT BOUNDARY
---	---	---	REGULATORY 100-YEAR FLOODPLAIN
---	---	---	PROPOSED 100-YEAR WSE
---	---	---	PROPOSED 2-YEAR WSE
---	---	---	PROPOSED WETLAND SWALE
---	---	---	PROPOSED SOIL RIPRAP (PLAN)
---	---	---	PROPOSED SOIL RIPRAP (SECTION)
---	---	---	PROPOSED VOID-PERMEATED RIPRAP (PLAN)
---	---	---	PROPOSED VOID-PERMEATED RIPRAP (SECTION)
---	---	---	PROPOSED GROUTED BOULDER (PLAN)
---	---	---	PROPOSED AGGREGATE ACCESS ROAD
---	---	---	TRUEGRID PAVERS
---	---	---	PROPOSED ARTICULATED CONCRETE MAT
---	---	---	PROPOSED CONCRETE
---	---	---	EXISTING SOIL CEMENT (PLAN)
---	---	---	EXISTING SOIL CEMENT (SECTION)
---	---	---	EXISTING CONCRETE
---	---	---	EXISTING CONCRETE RUBBLE/ EXISTING RIPRAP
---	---	---	EXISTING WETLANDS
---	---	---	EXISTING ASPHALT
---	---	---	EXISTING TREE
---	---	---	FLOW DIRECTION

ABBREVIATIONS

AVG	AVERAGE
BW	BOTTOM OF WALL (ELEV)
CBC	CONCRETE BOX CULVERT
CDPHE	COLORADO DEPARTMENT OF PUBLIC HEALTH AND ENVIRONMENT
CFS	CUBIC FEET PER SECOND
CL	CENTERLINE
CLR	CLEAR
CMP	CORRUGATED METAL PIPE
CONC	CONCRETE
CP	CONTROL POINT
D	DEPTH
D/S	DOWNSTREAM
DBPS	DRAINAGE BASIN PLANNING STUDY
DEMO	DEMOLISH
DET	DETAIL
DIA	DIAMETER
DWG	DRAWING
E	EACH
EA	EACH
EG	EXISTING GROUND
ELE/ELEV	ELEVATION
EOR	EDGE OF ROAD
EX/EXIST	EXISTING
FES	FLARED END SECTION
FG	FINISHED GRADE
FO	FIBER OPTIC
FT	FEET
H	HEIGHT
HDPE	HIGH DENSITY POLYETHYLENE PIPE
HOR	HORIZONTAL
HP	HIGH POINT
IN	INCH
INV	INVERT
LF	LINEAL FEET
MAX	MAXIMUM
MAINT	MAINTENANCE
MH	MANHOLE
MIN	MINIMUM
N	NORTHING
NO.	NUMBER
NTS	NOT TO SCALE
P&P	PLAN AND PROFILE
PR 100-YR	PROPOSED 100-YEAR FLOODPLAIN
PVC	POLYVINYL CHLORIDE PIPE
QL	UTILITY QUALITY LEVEL
RCP	REINFORCED CONCRETE PIPE
RD	ROAD
REG 100-YR	REGULATORY 100-YEAR FLOODPLAIN
ROW	RIGHT-OF-WAY
SAN	SANITARY [SEWER]
SHT	SHEET
SS	SANITARY SEWER
STA	STATION
STR	STRUCTURE
STRM	STORM SEWER
SWMP	STORM WATER MANAGEMENT PLAN
TOB	TOP OF BOULDER
TOG	TOP OF GROUT
TOS	TOP OF SLAB
TW	TOP OF WALL (ELEV)
TYP	TYPICAL
U/S	UPSTREAM
USBR	UNITED STATES BUREAU OF RECLAMATION
VERT	VERTICAL
W	WIDTH/WITH
WSEL/WSE	WATER SURFACE ELEVATION
WTR	WATER LINE
YR	YEAR

DETAIL

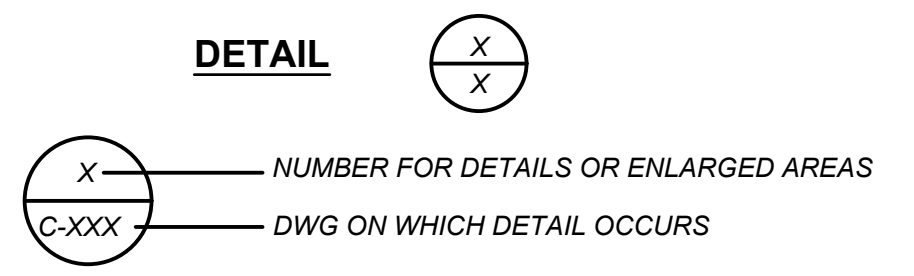

SECTION

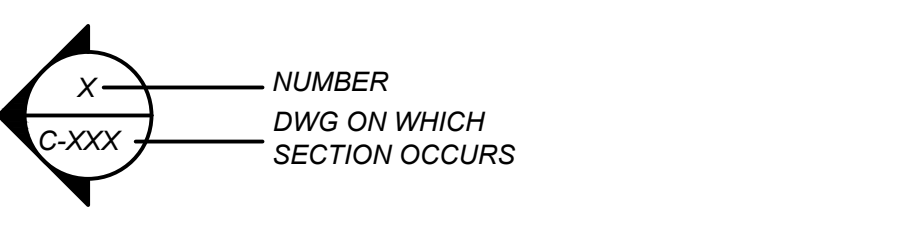

REV	REVISION DESCRIPTION	DATE	CHND	CHKD	APPR

CALL BEFORE YOU DIG

Know what's below.
Call before you dig.

CITY OF COLORADO SPRINGS
30 S. NEVADA AVE., SUITE 401
COLORADO SPRINGS, CO 80903
(719) 385-5980

MERRICK
 Engineering | Architecture | Design-Build | Surveying | Planning | Geospatial Solutions
 2480 W. 26TH AVE., UNIT B225 - DENVER COLORADO 80211
 TEL. 303-751-0741, FAX 303-751-2581
 www.merrick.com

PE STAMP

FOR AND ON BEHALF OF MERRICK & COMPANY

TITLE

SAND CREEK DETENTION POND NO. 2

GENERAL NOTES AND LEGEND

JOB NUMBER	65420975
DATE	AUGUST 2024
DWG	ID-102
SHEET	2 of 51

THE USER SHALL BE RESPONSIBLE FOR OBTAINING ALL NECESSARY PERMITS AND APPROVALS FROM ALL APPLICABLE AGENCIES AND AGENCIES. THE USER SHALL BE RESPONSIBLE FOR OBTAINING ALL NECESSARY PERMITS AND APPROVALS FROM ALL APPLICABLE AGENCIES AND AGENCIES. THE USER SHALL BE RESPONSIBLE FOR OBTAINING ALL NECESSARY PERMITS AND APPROVALS FROM ALL APPLICABLE AGENCIES AND AGENCIES.

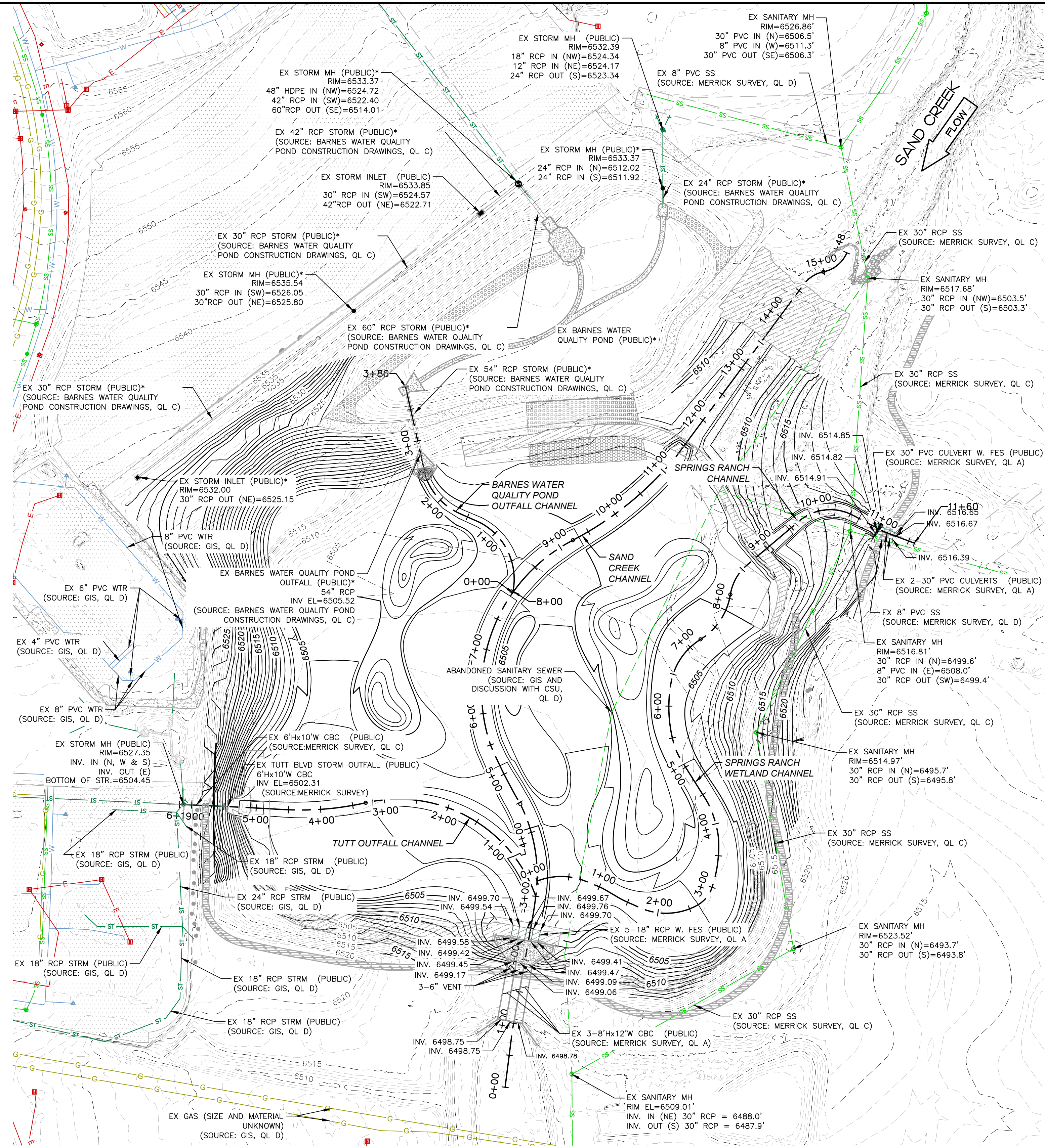

PLAN
SCALE: 1" = 100'

UTILITY NOTES:

- UTILITY LINES AS SHOWN ON THE PLANS ARE PLOTTED FROM THE BEST AVAILABLE INFORMATION. SUBSECTION 105.10 OF THE COT STANDARD SPECIFICATIONS FOR ROAD AND BRIDGE CONSTRUCTION, 2017 (AS REVISED) SHALL APPLY FOR THIS CONTRACT.
- THE INFORMATION SHOWN ON THESE PLANS CONCERNING TYPE AND LOCATION OF UTILITIES IS NOT GUARANTEED TO BE ACCURATE OR ALL INCLUSIVE. SERVICES TO INDIVIDUAL RESIDENCES, PLACES OF BUSINESS, AND OTHER PRIVATELY-OWNED UTILITIES ARE NORMALLY NOT SHOWN ON THE DRAWINGS. IT SHALL BE THE CONTRACTOR'S RESPONSIBILITY TO VERIFY ALL LOCATIONS OF EXISTING STRUCTURES AND UTILITIES SHOWN ON THE DRAWINGS AND TO ASCERTAIN WHETHER ANY OTHER STRUCTURES AND UTILITIES MAY EXIST. EVERY REASONABLE MEANS SHALL BE USED, INCLUDING FIELD LOCATION OF THE UTILITY. THE CONTRACTOR ASSUMES RESPONSIBILITY FOR THE PROTECTION OF ALL UTILITIES DURING THE WORK. REPAIR OF DAMAGE TO EXISTING UTILITIES DURING CONSTRUCTION SHALL BE THE RESPONSIBILITY OF THE CONTRACTOR. PRIOR TO ANY EXCAVATION, CONTACT THE UTILITY NOTIFICATION CENTER OF COLORADO (UNCC) AT: 1 (800) 922-1987 AT LEAST TWO WORKING DAYS PRIOR TO DIGGING.
- THE CONTRACTOR SHALL VERIFY AND DOCUMENT THE CONDITION OF EXISTING UTILITIES (VISIBLE FACILITIES) WITH THE ENGINEER AND REPRESENTATIVES FROM THE UTILITY COMPANIES PRIOR TO COMMENCEMENT OF CONSTRUCTION.
- IT IS SUGGESTED THAT THE CONTRACTOR INITIATE A REQUEST TO XCEL ENERGY FOR ANY CONSTRUCTION-RELATED TEMPORARY ELECTRICAL POWER SOURCES AS SOON AS POSSIBLE. IN SOME INSTANCES UP TO 30 DAYS MAY BE REQUIRED TO PROVIDE THE SOURCES.

DISCLAIMER REGARDING UNDERGROUND UTILITIES:

EXISTING UTILITIES ARE DEPICTED ON THESE DRAWINGS AND IN ACCORDANCE WITH THE ACHIEVED "QUALITY LEVELS" FOR EACH UTILITY AS DEFINED IN THE AMERICAN SOCIETY OF CIVIL ENGINEERS' DOCUMENT ASCE 38" STANDARD GUIDELINE FOR THE COLLECTION AND DEPICTION OF EXISTING SUBSURFACE UTILITY DATA" AND AS REQUIRED BY C.R.S. 9-1.5-101 ET. SEQ.

AS IT APPLIES TO THE DEPICTION OF EXISTING UNDERGROUND UTILITY INFORMATION, THE STAMP AND SEAL ON THIS UTILITY PLAN REFLECT ONLY THAT DEPICTION OF THE EXISTING UNDERGROUND UTILITY MEETS THE NOTED ASCE 38 QUALITY LEVEL, AND DOES NOT SERVE AS A GUARANTEE, REPRESENTATION, OR WARRANTY THAT THE DEPICTED UTILITIES EXIST IN THE NOTED LOCATIONS.

RELIANCE UPON THIS DATA FOR RISK MANAGEMENT PURPOSES DURING BIDDING DOES NOT RELIEVE THE EXCAVATOR OR UTILITY OWNER FROM FOLLOWING ALL APPLICABLE UTILITY DAMAGE PREVENTION STATUTES, POLICIES, AND/OR PROCEDURES DURING EXCAVATION. IT IS IMPORTANT THAT THE CONTRACTOR INVESTIGATES AND UNDERSTAND THE SCOPE OF WORK AND CONSULTS WITH THAT PROJECT OWNER AND THE ENGINEER REGARDING THE SCOPE AND LIMITS OF THE INVESTIGATIONS LEADING TO THESE UTILITY DEPICTIONS.

UTILITY QUALITY LEVEL DESCRIPTIONS:

- QUALITY LEVEL A:** PRECISE HORIZONTAL AND VERTICAL LOCATION OF UTILITIES OBTAINED BY THE ACTUAL EXPOSURE (OR VERIFICATION OF PREVIOUSLY EXPOSED AND SURVEYED UTILITIES) AND SUBSEQUENT MEASUREMENT OF SUBSURFACE UTILITIES, USUALLY AT A SPECIFIC POINT. MINIMALLY INTRUSIVE EXCAVATION EQUIPMENT IS TYPICALLY USED TO MINIMIZE THE POTENTIAL FOR UTILITY DAMAGE. A PRECISE HORIZONTAL AND VERTICAL LOCATION, AS WELL AS OTHER UTILITY ATTRIBUTES, IS SHOWN IN PLAN DOCUMENTS. ACCURACY IS USUALLY SET TO 15-MM VERTICAL AND TO APPLICABLE HORIZONTAL SURVEY AND MAPPING ACCURACY AS DEFINED OR EXPECTED BY THE PROJECT OWNER.
- QUALITY LEVEL B:** INFORMATION OBTAINED THROUGH THE APPLICATION OF APPROPRIATE SURFACE GEOPHYSICAL METHODS TO DETERMINE THE EXISTENCE AND APPROXIMATE HORIZONTAL POSITION OF SUBSURFACE UTILITIES. QUALITY LEVEL B DATA SHOULD BE REPRODUCIBLE BY SURFACE GEOPHYSICS AT ANY POINT OF THEIR DEPICTION. THIS INFORMATION IS SURVEYED TO APPLICABLE TOLERANCES DEFINED BY THE PROJECT AND REDUCED ONTO PLAN DOCUMENTS.
- QUALITY LEVEL C:** INFORMATION OBTAINED BY SURVEYING AND PLOTTING VISIBLE ABOVE-GROUND UTILITY FEATURES AND BY USING PROFESSIONAL JUDGMENT IN CORRELATING THIS INFORMATION TO QUALITY LEVEL D INFORMATION.
- QUALITY LEVEL D:** INFORMATION DERIVED FROM EXISTING RECORDS OR ORAL RECOLLECTIONS.

*THIS INFRASTRUCTURE ELEMENT IS PROPOSED AS PART OF THE BARNES WATER QUALITY POND PROJECT, WHICH IS TO BE COMPLETED BEFORE CONSTRUCTION OF SAND CREEK POND NO. 2 RESTORATION BEGINS.

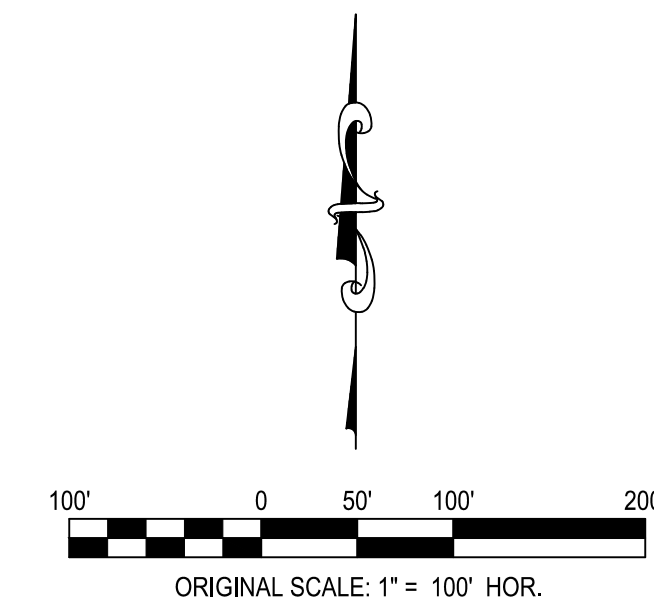

File Location: D:\Denver_North\Projects\City of Colorado Springs\Sand Creek Pond No. 2\CAD\CDS\0975-SUE.dwg Plot Date: 8/26/2024 4:24 PM Last Saved By: TIM.MCWULLEN

REV	REVISION DESCRIPTION	DATE	CHND	CHKD	APPR

CALL BEFORE YOU DIG

Know what's below.
Call before you dig.

CITY OF COLORADO SPRINGS
30 S. NEVADA AVE., SUITE 401
COLORADO SPRINGS, CO 80903
(719) 385-5980

MERRICK
Engineering | Architecture | Design-Build | Surveying | Planning | Geospatial Solutions
2480 W. 26TH AVE., UNIT B225 - DENVER COLORADO 80211
TEL. 303-751-0741, FAX 303-751-2581
www.merrick.com

PE STAMP

FOR AND ON BEHALF OF MERRICK & COMPANY

TITLE

SAND CREEK DETENTION POND NO. 2

SUBSURFACE UTILITY ENGINEERING PLAN

JOB NUMBER	65420975
DATE	AUGUST 2024
DWG	C-101
SHEET	3 of 51

THE CITY OF COLORADO SPRINGS, COLORADO, IS PROVIDING THIS INFORMATION AS AN INSTRUMENT OF SERVICE. THE CITY OF COLORADO SPRINGS, COLORADO, DOES NOT WARRANT THE ACCURACY OF ANY INFORMATION PROVIDED HEREON. THE CITY OF COLORADO SPRINGS, COLORADO, DOES NOT WARRANT THE ACCURACY OF ANY INFORMATION PROVIDED HEREON. THE CITY OF COLORADO SPRINGS, COLORADO, DOES NOT WARRANT THE ACCURACY OF ANY INFORMATION PROVIDED HEREON.

File Location: D:\Denver_North\Projects\City of Colorado Springs\Sand Creek Pond No. 2\CAD\CDS\0975-PROJECT_CONTROL.SDWG Plot Date: 8/26/2024 4:27 PM Last Saved By: TIM.MCMULLEN

MATCHLINE SEE DWG C-103

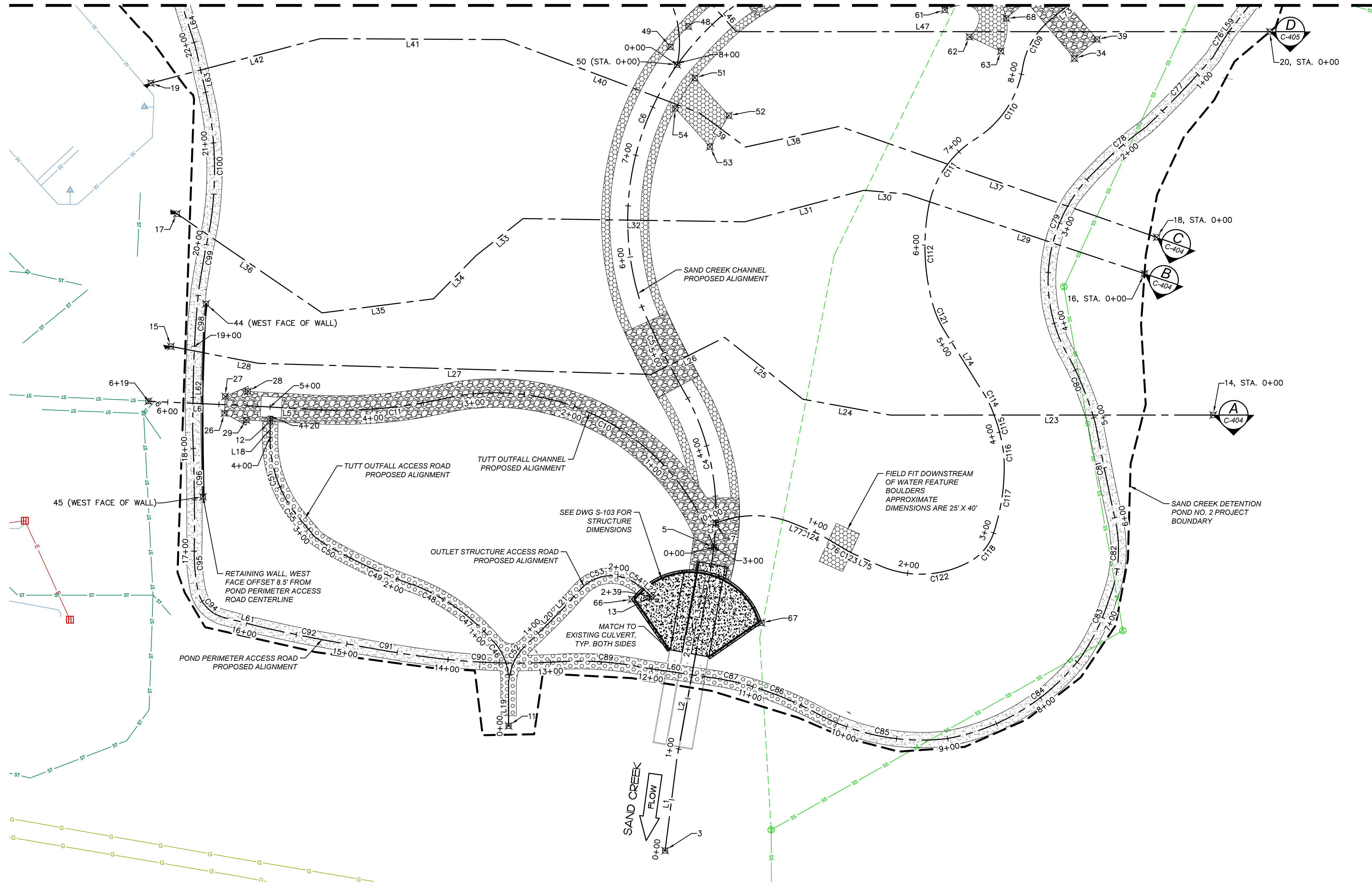

- NOTES:
- SEE LINE, CURVE, AND POINT TABLES ON THE NEXT DRAWING, DWG C-103.
 - POINTS 66 AND 67 ARE APPROXIMATE LOCATIONS. FOLLOW DIMENSIONS ON DWG S-103, USING THE CORNERS OF THE EXISTING CONCRETE BOX CULVERT AS REFERENCE LOCATIONS.

PLAN
SCALE 1" = 50'

REV	REVISION DESCRIPTION	DATE	CHND	CHKD	APPR

CALL BEFORE YOU DIG

Know what's below.
Call before you dig.

CITY OF COLORADO SPRINGS
30 S. NEVADA AVE., SUITE 401
COLORADO SPRINGS, CO 80903
(719) 385-5980

Engineering | Architecture | Design-Build | Surveying | Planning | Geospatial Solutions
2480 W. 26TH AVE., UNIT B225 - DENVER COLORADO 80211
TEL. 303-751-0741, FAX 303-751-2581
www.merrick.com

PE STAMP

FOR AND ON BEHALF OF MERRICK & COMPANY

TITLE

SAND CREEK DETENTION POND NO. 2

PROJECT CONTROLS (SOUTH)

JOB NUMBER 65420975

DATE AUGUST 2024

DWG C-102

SHEET 4 of 51

FILE LOCATION: D:\Denver_North\Projects\City of Colorado Springs\Sand Creek Pond No. 2\CAD\CCS\0975-PROJECT_CONTROL\DWG_Plot Date: 8/26/2024 4:27 PM Last Saved By: TIM.MCMULLEN
 THE USER HAS BEEN ADVISED BY THE MERRICK COMPANY THAT THE INFORMATION ON THIS DRAWING IS UNDETAILED AND SHOULD NOT BE USED FOR CONSTRUCTION OR FOR ANY OTHER PURPOSE. IT IS NOT INTENDED OR WARRANTED TO BE SUITABLE FOR FOUNDATION OR FOUNDATION DESIGN. THE MERRICK COMPANY IS NOT RESPONSIBLE FOR ANY DAMAGE TO PROPERTY OR PERSONS ARISING FROM ANY USE OF THIS DRAWING. THE USER SHALL BE RESPONSIBLE FOR THE DESIGN AND CONSTRUCTION OF ANY STRUCTURE OR STRUCTURES. THE MERRICK COMPANY IS NOT RESPONSIBLE FOR THE DESIGN AND CONSTRUCTION OF ANY STRUCTURE OR STRUCTURES. THE MERRICK COMPANY IS NOT RESPONSIBLE FOR THE DESIGN AND CONSTRUCTION OF ANY STRUCTURE OR STRUCTURES.

Curve Table

Curve #	Length	Radius	Delta	Chord Direction	Chord Length
C1	89.29	75.00	68.21	S83° 54' 20"W	84.11
C3	129.04	246.79	29.96	N11° 36' 40"W	127.58
C4	129.04	246.79	29.96	N11° 36' 40"W	127.58
C5	102.59	817.89	7.19	N26° 46' 25"W	102.52
C6	372.92	262.95	81.26	N21° 51' 26"E	342.45
C7	209.25	515.43	23.26	N50° 51' 22"E	207.82
C8	224.94	805653.01	0.02	N36° 08' 25"E	224.94
C10	329.40	225.64	83.64	N61° 10' 11"W	300.92
C11	127.76	462.93	15.81	S85° 16' 16"W	127.35
C46	59.77	61.60	55.60	N20° 55' 04"W	57.46
C47	35.55	213.12	9.56	N47° 54' 31"W	35.51
C48	47.55	189.78	14.36	N60° 27' 46"W	47.43
C49	74.74	510.11	8.39	N66° 59' 19"W	74.67
C50	37.79	194.91	11.11	N58° 54' 37"W	37.73
C51	80.98	119.40	38.86	N18° 43' 13"W	79.44
C52	44.74	56.00	45.77	N22° 53' 12"E	43.56
C53	54.55	41.27	75.73	N79° 41' 18"E	50.67
C54	13.84	81.65	9.71	S55° 31' 28"E	13.82
C55	80.98	119.40	38.86	N18° 43' 13"W	79.44
C71	80.12	99.85	45.97	N43° 34' 10"W	77.99
C73	129.97	99.05	75.18	N25° 24' 09"W	120.84
C74	38.34	1028.81	2.14	N37° 04' 52"E	38.34
C76	29.15	440.20	3.79	N31° 56' 41"E	29.14
C77	94.99	904.96	6.01	N43° 46' 03"E	94.95
C78	64.57	341.60	10.83	N49° 07' 33"E	64.47
C79	200.42	147.29	77.96	N7° 59' 43"E	185.31
C80	68.43	342.14	11.46	N21° 35' 53"W	68.32
C81	97.99	3957.92	1.42	N11° 37' 41"W	97.98
C82	76.26	131.11	33.33	N4° 37' 37"E	75.19
C83	63.19	221.84	16.32	N25° 39' 59"E	62.98

Curve Table

Curve #	Length	Radius	Delta	Chord Direction	Chord Length
C85	131.10	213.64	35.16	S78° 54' 49"E	129.05
C86	76.67	347.53	12.64	S68° 09' 24"E	76.51
C87	28.10	283.04	5.69	S78° 20' 42"E	28.09
C89	86.00	319.97	15.40	S85° 52' 43"E	85.74
C90	125.56	653.71	11.00	S88° 04' 34"E	125.37
C91	74.39	1221.53	3.49	S80° 49' 44"E	74.38
C92	93.71	1316.30	4.08	S78° 56' 53"E	93.69
C94	39.72	35.00	65.03	S43° 14' 56"E	37.62
C95	47.33	197.07	13.76	S3° 51' 18"E	47.22
C96	108.24	2277.74	2.72	S0° 57' 14"E	108.23
C98	84.26	987.49	4.89	S3° 36' 48"W	84.24
C99	62.31	1284.97	2.78	S10° 10' 56"E	62.30
C100	117.10	346.44	19.37	S0° 39' 36"E	116.54
C103	325.01	163.88	113.63	S39° 27' 09"W	274.30
C104	11.86	75.00	9.06	N79° 12' 09"W	11.85
C105	27.88	315.15	5.07	N77° 39' 26"W	27.88
C109	53.48	75.00	40.85	S29° 22' 26"W	52.35
C110	86.10	100.00	49.33	S33° 36' 45"W	83.46
C111	80.72	100.00	46.25	S35° 09' 11"W	78.55
C112	97.04	212.28	26.19	S2° 02' 39"E	96.19
C114	16.77	100.00	9.61	S27° 16' 54"E	16.75
C115	38.09	175.45	12.44	S16° 15' 34"E	38.01
C116	14.44	100.00	8.27	S5° 54' 18"E	14.42
C117	71.40	202.69	20.18	S8° 19' 19"W	71.03
C118	37.66	50.00	43.16	S39° 59' 30"W	36.78
C121	29.58	100.00	16.95	S23° 36' 44"E	29.47
C122	91.81	100.00	52.60	S87° 52' 21"W	88.62
C123	11.04	100.00	6.32	N62° 39' 49"W	11.03
C124	19.21	116.64	9.44	N64° 30' 55"W	19.19

Line Table

Line #	Length	Direction
L1	90.00	N7° 17' 50.89"E
L2	103.65	N10° 12' 34.73"E
L3	79.70	N10° 04' 19.60"E
L5	65.25	N86° 49' 21.37"W
L6	96.54	N87° 24' 02.07"W
L18	15.76	N0° 39' 27.50"E
L19	38.74	N0° 00' 02.09"E
L20	43.05	N43° 05' 15.56"E
L21	43.05	N43° 05' 15.56"E
L22	11.63	S47° 05' 53.21"E
L23	315.24	S89° 59' 39.30"W
L24	86.97	N79° 44' 15.29"W
L25	97.34	N51° 42' 06.71"W
L26	80.34	S63° 17' 43.12"W
L27	383.67	N88° 23' 18.76"W
L28	86.93	N79° 02' 21.54"W
L29	245.02	N71° 31' 05.84"W
L30	41.65	N84° 52' 48.68"W
L31	120.48	S75° 12' 06.67"W
L32	216.52	N89° 10' 15.14"W
L33	58.40	S51° 47' 44.07"W
L34	59.31	S44° 35' 33.76"W
L35	109.73	S82° 49' 47.55"W
L36	171.58	N55° 39' 22.52"W
L37	327.94	N70° 41' 15.94"W
L38	94.38	S77° 33' 48.47"W
L39	55.76	N53° 23' 14.40"W
L40	203.60	N69° 23' 18.90"W
L41	179.66	N89° 41' 15.88"W
L42	171.24	S75° 17' 39.74"W

Line Table

Line #	Length	Direction
L43	226.39	S27° 28' 58.16"E
L44	209.37	S71° 55' 56.72"E
L45	145.40	S87° 42' 53.87"E
L46	41.83	S42° 15' 27.83"E
L47	521.03	N90° 00' 00.00"E
L57	144.26	N12° 36' 45.22"W
L58	31.75	N66° 08' 13.24"W
L59	9.89	N38° 34' 03.92"E
L60	68.73	S81° 39' 41.43"E
L61	37.24	S75° 45' 44.35"E
L62	54.40	S0° 52' 11.04"W
L63	59.50	S12° 38' 57.26"E
L64	39.76	S17° 38' 56.26"E
L66	59.63	N68° 16' 06.74"W
L68	71.41	S49° 48' 01.86"W
L72	45.05	N61° 59' 22.10"W
L73	34.47	S49° 48' 01.86"W
L74	72.19	S32° 05' 06.54"E
L75	24.08	N65° 49' 31.47"W
L76	23.44	N59° 30' 07.16"W
L77	20.34	N67° 46' 42.69"W

Point Table

Point #	Northing	Easting
3	1386008.7721	3225597.8362
4	1387302.9105	3226127.4942
5	1386304.8244	3225645.3754
6	1386447.4272	3225093.2483
7	1386328.4432	3225647.4390
8	1386852.5222	3226232.3066
10	1386846.7073	3226177.7638
11	1386130.4691	3225445.0104
12	1386427.7967	3225212.2683
13	1386256.6482	3225584.4582
14	1386433.9527	3226133.0910
15	1386500.9559	3225115.2534
16	1386572.0018	3226066.0137

Point Table

Point #	Northing	Easting
17	1386630.4965	3225121.1128
18	1386607.4226	3226077.9409
19	1386757.9918	3225095.6753
20	1386808.2463	3226188.3852
21	1387110.7720	3225190.4276
24	1387095.1993	3225443.5577
25	1386967.7222	3225472.0816
26	1386435.6769	3225167.5422
27	1386452.1290	3225168.2035
28	1386457.0276	3225190.4603
29	1386429.0706	3225188.9083
30	1386958.5462	3225461.9410
31	1386963.7868	3225485.3619

Point Table

Point #	Northing	Easting
33	1386994.2188	3225814.3606
34	1386781.9516	3225997.5657
35	1386844.5510	3225919.9806
36	1387195.0911	3225924.8227
37	1387106.8063	3226066.3008
38	1386873.0092	3225958.5854
39	1386800.6697	3226019.7160
44	1386542.5246	3225149.5559
45	1386354.2096	3225146.6043
48	1386813.1803	3225620.6443
49	1386793.3853	3225603.1758
50	1386775.9073	3225609.6852
51	1386763.1272	3225626.8746

Point Table

Point #	Northing	Easting
52	1386726.3315	3225660.1359
53	1386695.8995	3225641.6479
54	1386733.2181	3225607.8584
56	1386874.2799	3225442.8570
57	1386845.4350	3225463.7226
58	1386844.4040	3225510.6752
59	1386857.5342	3225553.1033
60	1386864.5837	3225862.1692
61	1386829.5000	3225870.9410
62	1386803.2273	3225895.0599
63	1386789.1356	3225925.7303
64	1386947.8777	3225892.7284
66	1386254.0753	3225565.3155

Point Table

Point #	Northing	Easting
67	1386231.0454	3225692.0872
68	1386821.2323	3225931.0545
69	1386837.6575	3225950.4914
70	1386966.0970	3225636.9313
71	1386977.4193	3225823.8808

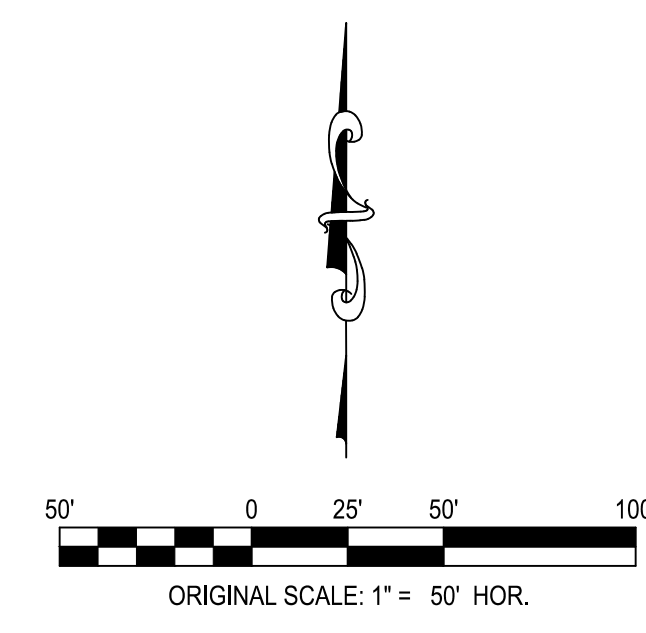
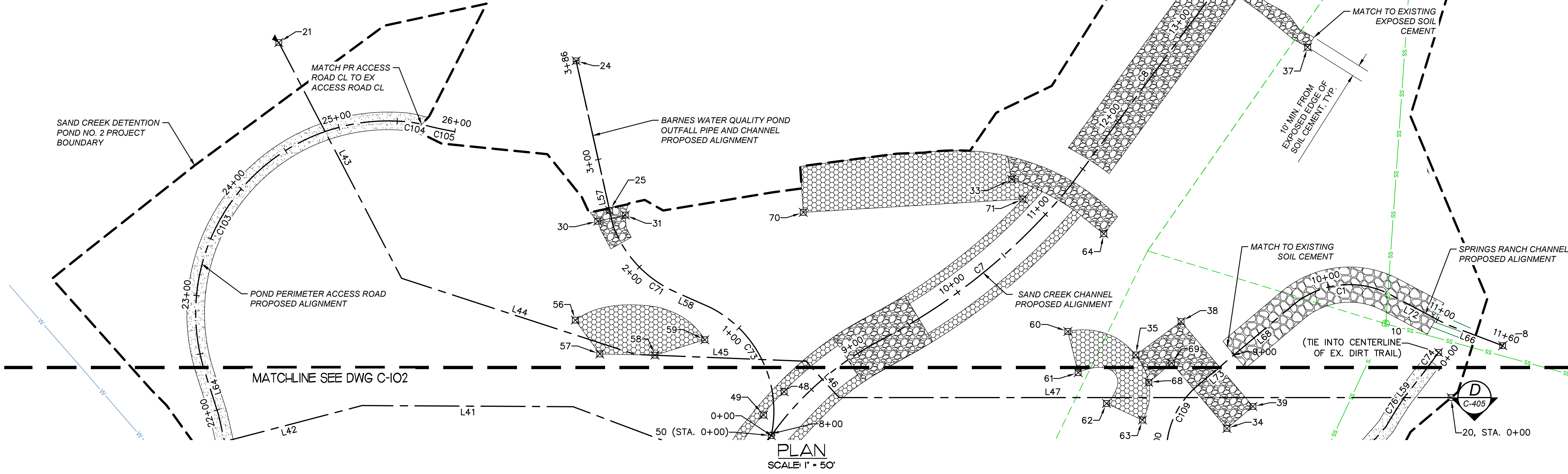

REV	REVISION DESCRIPTION	DATE	CHND	CHKD	APPR



CITY OF COLORADO SPRINGS
 30 S. NEVADA AVE., SUITE 401
 COLORADO SPRINGS, CO 80903
 (719) 385-5980

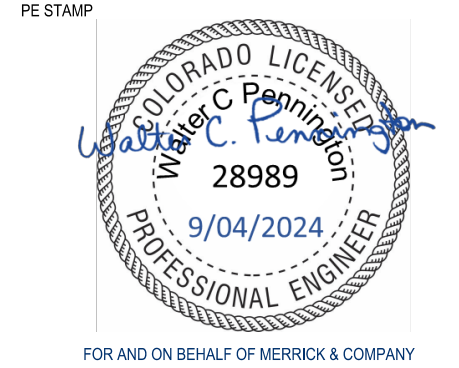

SAND CREEK DETENTION POND NO. 2
 PROJECT CONTROLS (NORTH)

JOB NUMBER: 65420975	DATE: AUGUST 2024
DWG: C-103	
SHEET 5 of 51	

THE CITY OF COLORADO SPRINGS IS PROVIDING THIS INFORMATION AS AN INSTRUMENT OF SERVICE. SERVICES PROVIDED BY MERRICK AND COMPANY, INC. ARE THE PROPERTY OF MERRICK AND COMPANY, INC. AND ARE NOT TO BE REPRODUCED OR TRANSMITTED IN ANY FORM OR BY ANY MEANS, ELECTRONIC OR MECHANICAL, INCLUDING PHOTOCOPYING, RECORDING, OR BY ANY INFORMATION STORAGE AND RETRIEVAL SYSTEM, WITHOUT THE WRITTEN PERMISSION OF MERRICK AND COMPANY, INC. THIS INFORMATION IS PROVIDED AS IS AND WITHOUT WARRANTY OF ANY KIND, INCLUDING MERCHANTABILITY AND FITNESS FOR A PARTICULAR PURPOSE. THE USER SHALL BE RESPONSIBLE FOR OBTAINING ALL NECESSARY PERMITS AND APPROVALS FROM THE APPROPRIATE AGENCIES.

File Location: D:\Denver_North\Projects\City of Colorado Springs\Sand Creek Pond No. 2\CAD\CCS\0975- EXISTING CONDITIONS.dwg Plot Date: 9/26/2024 4:27 PM Last Saved By: TIMMCMULLEN

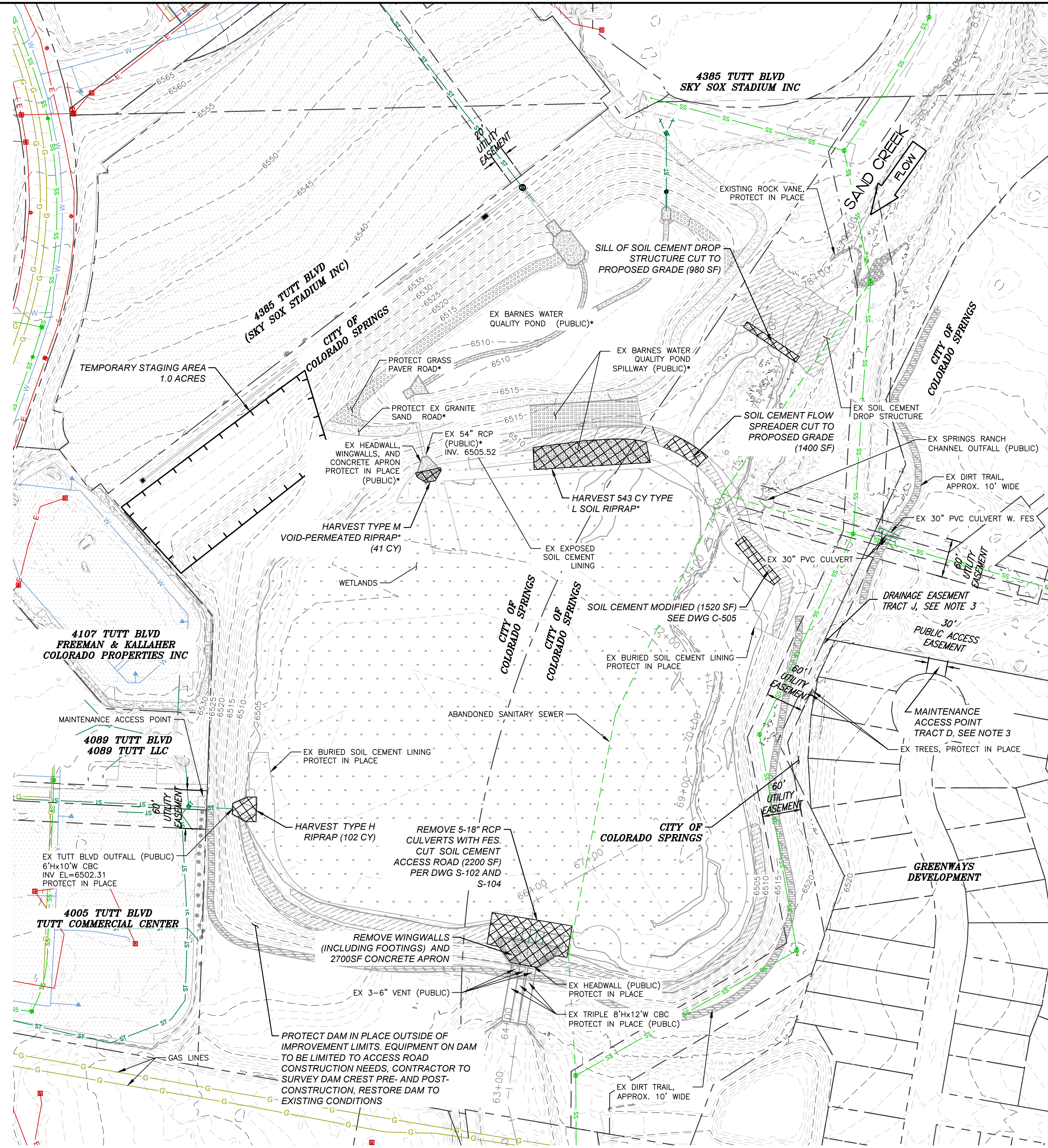

PLAN
SCALE: 1" = 100'

- NOTES:
1. PROPERTY OWNERSHIP INFORMATION RETRIEVED FROM CITY OF COLORADO SPRINGS SPRINGVIEW WEBSITE
 2. EASEMENT INFORMATION PROVIDED BY GREENWAYS DEVELOPMENT AND DRAINAGE REPORTS.
 3. TRACT D FROM THE GREENWAYS DEVELOPMENT IS USED FOR PUBLIC ACCESS, OPEN SPACE, LANDSCAPING, PUBLIC UTILITIES, PUBLIC IMPROVEMENTS, TRAILS, FENCES AND SIGNAGE. TRACT J IS USED FOR PUBLIC DRAINAGE, PUBLIC UTILITIES, AND TRAILS/OPEN SPACE.

*THIS INFRASTRUCTURE ELEMENT IS PROPOSED AS PART OF THE BARNES WATER QUALITY POND PROJECT, WHICH IS TO BE COMPLETED BEFORE CONSTRUCTION OF SAND CREEK POND NO. 2 RESTORATION BEGINS.

REV	REVISION DESCRIPTION	DATE	CHND	CHKD	APPR

CALL BEFORE YOU DIG

Know what's below.
Call before you dig.

CITY OF COLORADO SPRINGS
30 S. NEVADA AVE., SUITE 401
COLORADO SPRINGS, CO 80903
(719) 385-5980

MERRICK
Engineering | Architecture | Design-Build | Surveying | Planning | Geospatial Solutions
2480 W. 26TH AVE., UNIT B225 - DENVER COLORADO 80211
TEL. 303-751-0741, FAX 303-751-2581
www.merrick.com

PE STAMP

FOR AND ON BEHALF OF MERRICK & COMPANY

TITLE

SAND CREEK DETENTION POND NO. 2

EXISTING CONDITIONS, PROPERTY OWNERSHIP,
AND DEMOLITION PLAN

JOB NUMBER: 65420975
DATE: AUGUST 2024
DWG: C-201
SHEET: 6 of 51

THE NEW ORANGE ENGINEERING ARCHITECTURE AND SURVEYING COMPANY, INC. (NEW ORANGE) IS THE ENGINEER OF RECORD FOR THIS PROJECT. IT IS NOT INTENDED OR REPRESENTED TO BE A PART OR PART AND EXTENSION OF THE PROJECT OR ON ANY OTHER PROJECT. REUSE OR MODIFICATION OF ANY INFORMATION NOT A FINISHED INSTRUMENT WITHOUT THE PRIOR EXPRESS WRITTEN CONSENT OF NEW ORANGE ENGINEERING ARCHITECTURE AND SURVEYING COMPANY SHALL BE AT THE USER'S RISK. THE USER ASSUMES ALL LIABILITY FOR USE OF THIS DOCUMENT.

File Location: D:\Denver_North\Projects\City of Colorado Springs\Sand Creek Pond No. 2\CAD\03\0975-CONSTRUCTION-ACCESS.dwg Plot Date: 8/26/2024 4:28 PM Last Saved By: TIM.MCMULLEN

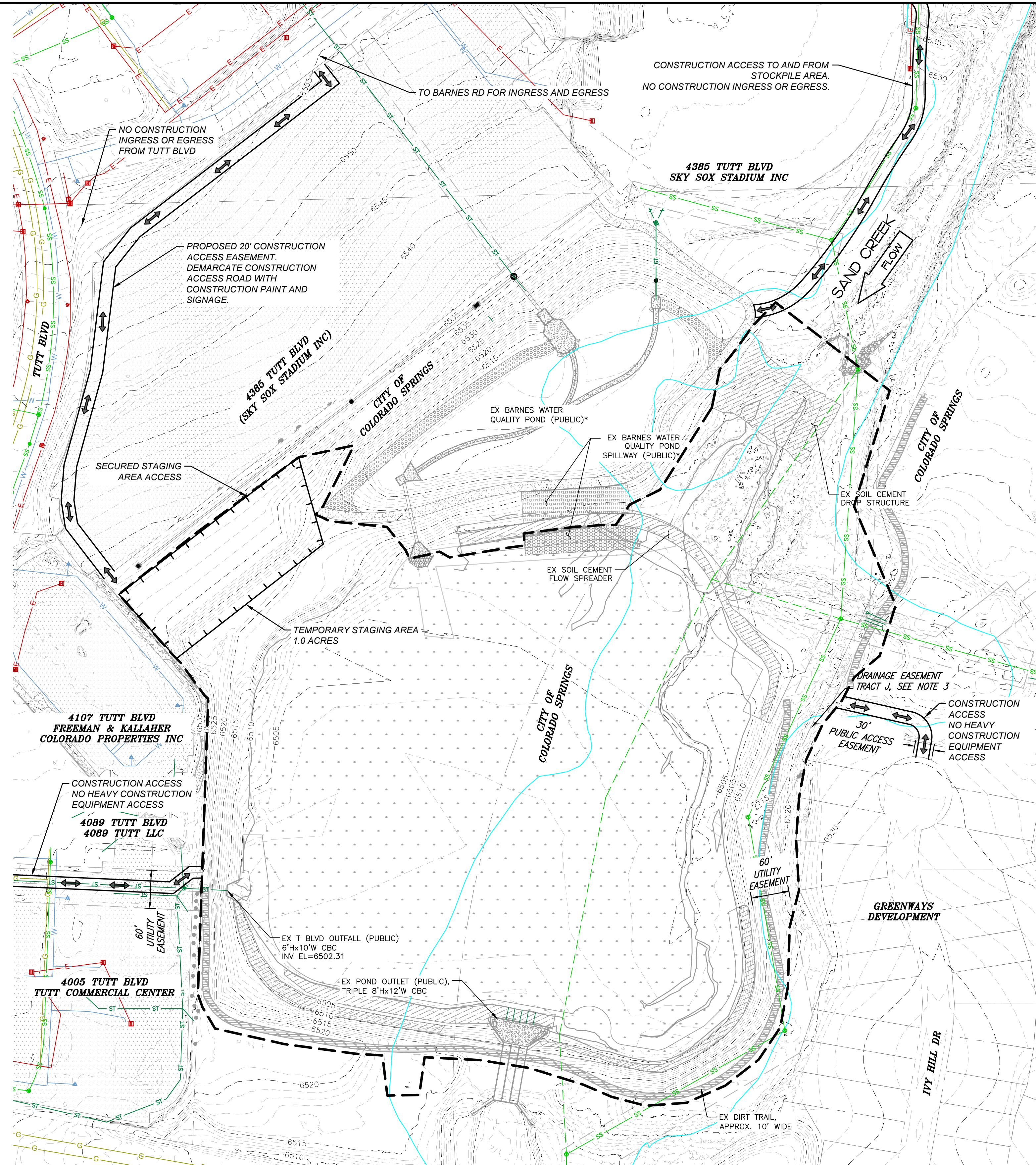

PLAN
SCALE: 1" = 100'

- NOTES:
1. PROPERTY OWNERSHIP INFORMATION RETRIEVED FROM CITY OF COLORADO SPRINGS SPRINGSVIEW WEBSITE
 2. EASEMENT INFORMATION PROVIDED BY GREENWAYS DEVELOPMENT AND DRAINAGE REPORTS
 3. TRACT D FROM THE GREENWAYS DEVELOPMENT IS USED FOR PUBLIC ACCESS, OPEN SPACE, LANDSCAPING, PUBLIC UTILITIES, PUBLIC IMPROVEMENTS, TRAILS, FENCES AND SIGNAGE. TRACT J IS USED FOR PUBLIC DRAINAGE, PUBLIC UTILITIES, AND TRAILS/OPEN SPACE.

*THIS INFRASTRUCTURE ELEMENT IS PROPOSED AS PART OF THE BARNES WATER QUALITY POND PROJECT, WHICH IS TO BE COMPLETED BEFORE CONSTRUCTION OF SAND CREEK POND NO. 2 RESTORATION BEGINS.

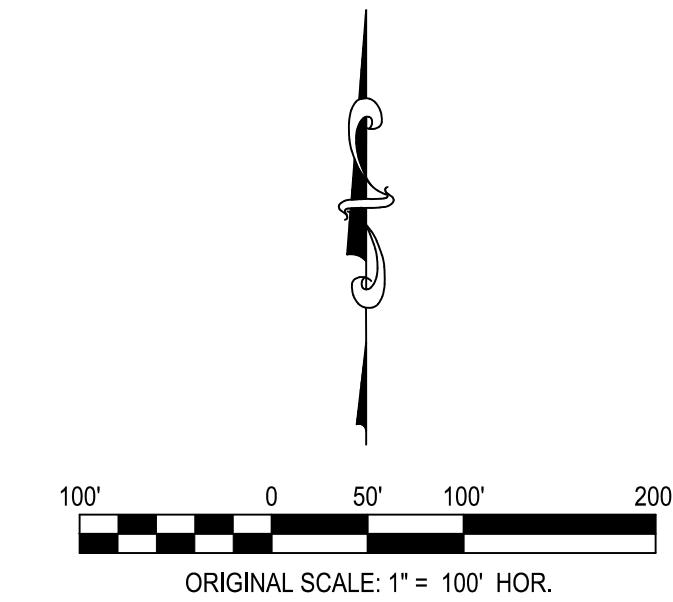

REV	REVISION DESCRIPTION	DATE	CHND	CHKD	APPR

CALL BEFORE YOU DIG

Know what's below.
Call before you dig.

CITY OF COLORADO SPRINGS
30 S. NEVADA AVE., SUITE 401
COLORADO SPRINGS, CO 80903
(719) 385-5980

Engineering | Architecture | Design-Build | Surveying | Planning | Geospatial Solutions
2480 W. 26TH AVE., UNIT B225 - DENVER COLORADO 80211
TEL. 303-751-0741, FAX 303-751-2581
www.merrick.com

PE STAMP

FOR AND ON BEHALF OF MERRICK & COMPANY

TITLE

SAND CREEK DETENTION POND NO. 2

CONSTRUCTION ACCESS, STAGING, AND GENERAL TRAFFIC CONTROL

JOB NUMBER 65420975

DATE AUGUST 2024

DWG C-301

SHEET 7 of 51

THE CITY OF COLORADO SPRINGS HAS REVIEWED THIS PLAN FOR CONFORMANCE WITH THE CITY OF COLORADO SPRINGS DESIGN STANDARDS MANUAL. THE CITY'S REVIEW IS LIMITED TO TECHNICAL ASPECTS OF THE PLAN AND DOES NOT CONSTITUTE A GUARANTEE OF THE ACCURACY OF THE INFORMATION PROVIDED HEREON. THE CITY OF COLORADO SPRINGS DOES NOT WARRANT THE ACCURACY OF THE INFORMATION PROVIDED HEREON. THE CITY OF COLORADO SPRINGS DOES NOT WARRANT THE ACCURACY OF THE INFORMATION PROVIDED HEREON. THE CITY OF COLORADO SPRINGS DOES NOT WARRANT THE ACCURACY OF THE INFORMATION PROVIDED HEREON.

File Location: D:\Denver_North\Projects\City of Colorado Springs\Sand Creek Pond No. 2\CAD\CCS\0975-SITE_PLAN\KEY.dwg Plot Date: 8/26/2024 5:22 PM Last Saved By: TIM.MCMULLEN

NOTE: HARVEST AND STOCKPILE 1-FOOT DEPTH OF TOPSOIL FROM THE POND BOTTOM. THIS STOCKPILE IS REFERRED TO AS TOPSOIL STOCKPILE #1. THE POND BOTTOM IS APPROXIMATELY DEFINED AS THE AREA SHOWN AS WETLANDS ON DWG. C-201. HARVEST AND STOCKPILE AN ADDITIONAL 6-INCH DEPTH OF TOPSOIL FROM THE POND BOTTOM. THIS STOCKPILE IS REFERRED TO AS TOPSOIL STOCKPILE #2. DO NOT MIX TOPSOIL STOCKPILE #1 AND TOPSOIL STOCKPILE #2. PLACE TOPSOIL FROM TOPSOIL STOCKPILE #1 AS THE TOP 6-INCHES OF FINISHED GRADE ON ALL AREAS WITH UPLAND SEED SHOWN ON DWG. L-100. HAUL ALL REMAINING TOPSOIL FROM TOPSOIL STOCKPILE #1 TO THE OFFSITE STOCKPILE LOCATION. DO NOT MIX WITH OTHER OFFSITE STOCKPILES. PLACE TOPSOIL FROM TOPSOIL STOCKPILE #2 AS THE TOP 6-INCHES OF FINISHED GRADE ON ALL AREAS WITH WETLAND/RIPARIAN SEED OR WETLAND PLUGS SHOWN ON DWG. L-100. HAUL ALL REMAINING TOPSOIL FROM TOPSOIL STOCKPILE #2 TO THE OFFSITE STOCKPILE LOCATION. DO NOT MIX WITH OTHER OFFSITE STOCKPILES.

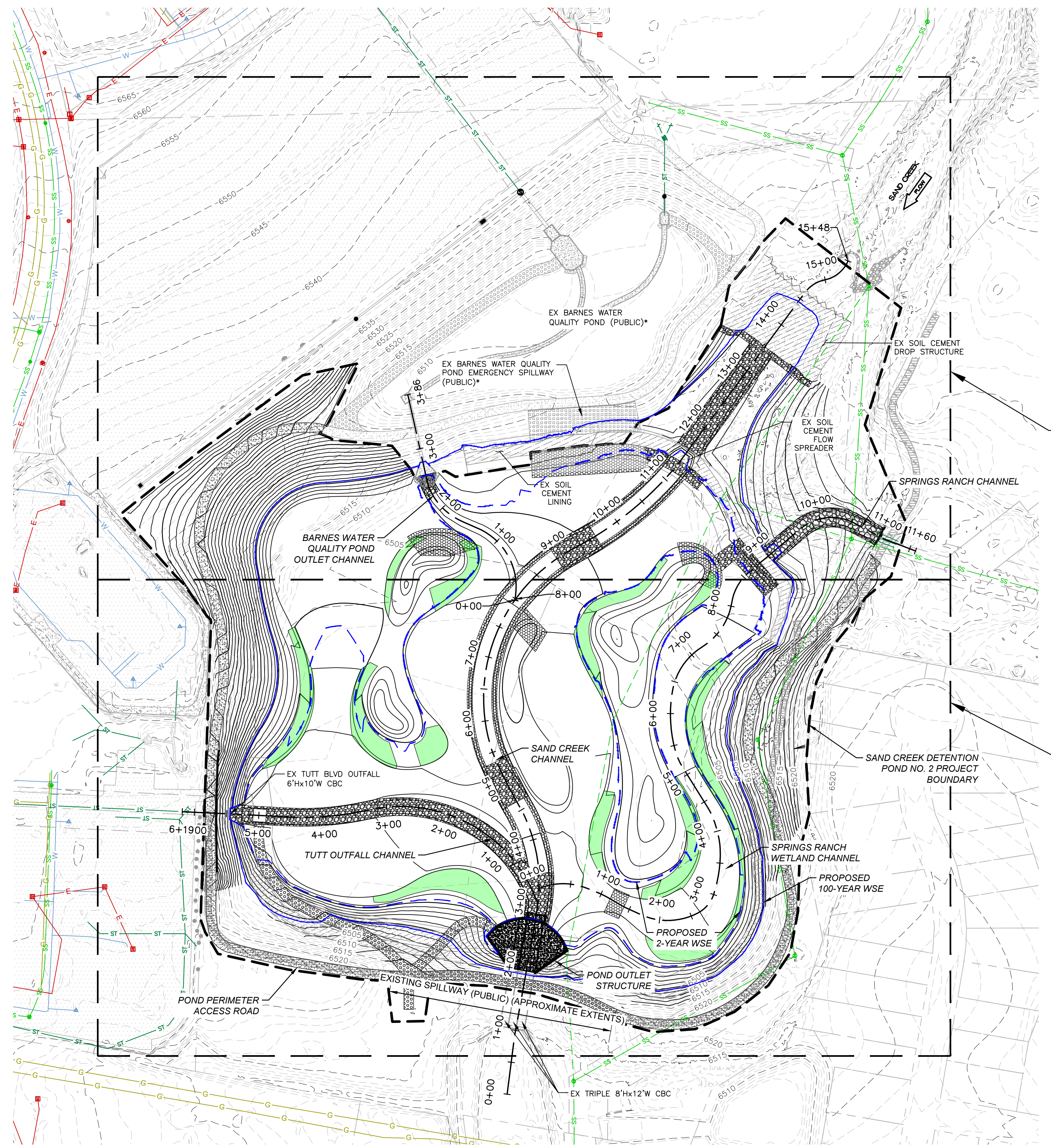

PLAN
 SCALE: 1" = 100'

**SAND CREEK POND NO. 2
STAGE-STORAGE TABLE**

ELEVATION (FT)	AREA (AC)	STORAGE (AC-FT)	RELEASE RATE (CFS)
6499.6	0.0	0.0	0
6500	0.1	0.0	20
6501	0.3	0.2	150
6502	1.0	0.9	345
6503	2.9	2.8	375
6504	5.1	6.8	490
6505	7.3	13.0	815
6506	10.3	21.8	890
6507	11.6	32.7	955
6508	12.5	44.8	1025
6509	13.5	57.8	1150
6510	14.6	71.8	1265
6511	15.9	87.1	2895
6512	17.1	103.6	3680
6513	17.9	121.1	4000

DBPS 100-YR FLOW RATE = 2489 CFS

SEE DWG C-403 - GRADING PLAN (NORTH)

*THIS INFRASTRUCTURE ELEMENT IS PROPOSED AS PART OF THE BARNES WATER QUALITY POND PROJECT, WHICH IS TO BE COMPLETED BEFORE CONSTRUCTION OF SAND CREEK POND NO. 2 RESTORATION BEGINS.

SEE DWG C-402 - GRADING PLAN (SOUTH)

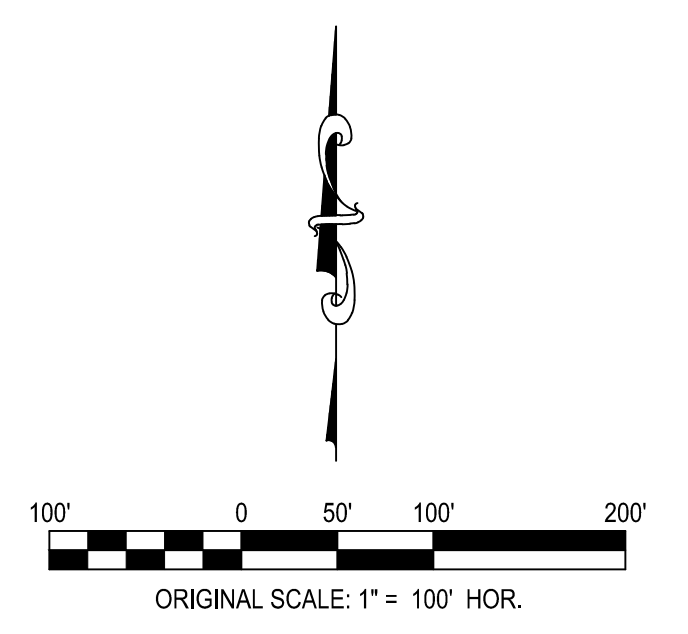

REV	REVISION DESCRIPTION	DATE	CHND	CHKD	APPR

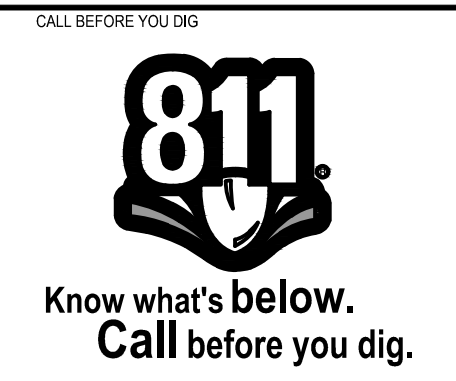

CITY OF COLORADO SPRINGS
 30 S. NEVADA AVE., SUITE 401
 COLORADO SPRINGS, CO 80903
 (719) 385-5980

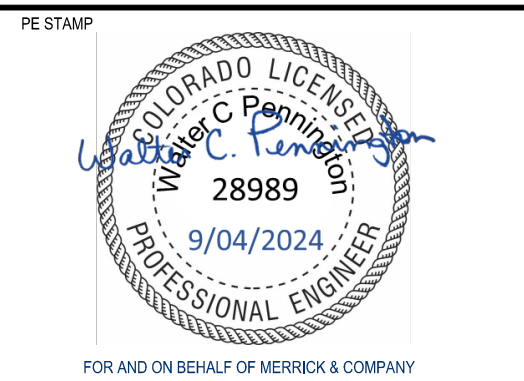

SAND CREEK DETENTION POND NO. 2
 OVERALL GRADING PLAN AND KEY MAP

JOB NUMBER	65420975
DATE	AUGUST 2024
DWG	C-401
SHEET	8 of 51

THE USER SHALL BE RESPONSIBLE FOR OBTAINING ALL NECESSARY PERMITS AND APPROVALS FROM ALL APPLICABLE AGENCIES AND AUTHORITIES. THE USER SHALL BE RESPONSIBLE FOR OBTAINING ALL NECESSARY PERMITS AND APPROVALS FROM ALL APPLICABLE AGENCIES AND AUTHORITIES. THE USER SHALL BE RESPONSIBLE FOR OBTAINING ALL NECESSARY PERMITS AND APPROVALS FROM ALL APPLICABLE AGENCIES AND AUTHORITIES.

File Location: D:\Denver_North\Projects\City of Colorado Springs\Sand Creek Pond No. 2\CAD\CDS\0975-SITE_PLAN.dwg Pk1 Date: 8/26/2024 4:30 PM Last Saved By: TIM.MCMULLEN

MATCHLINE SEE DWG C-403

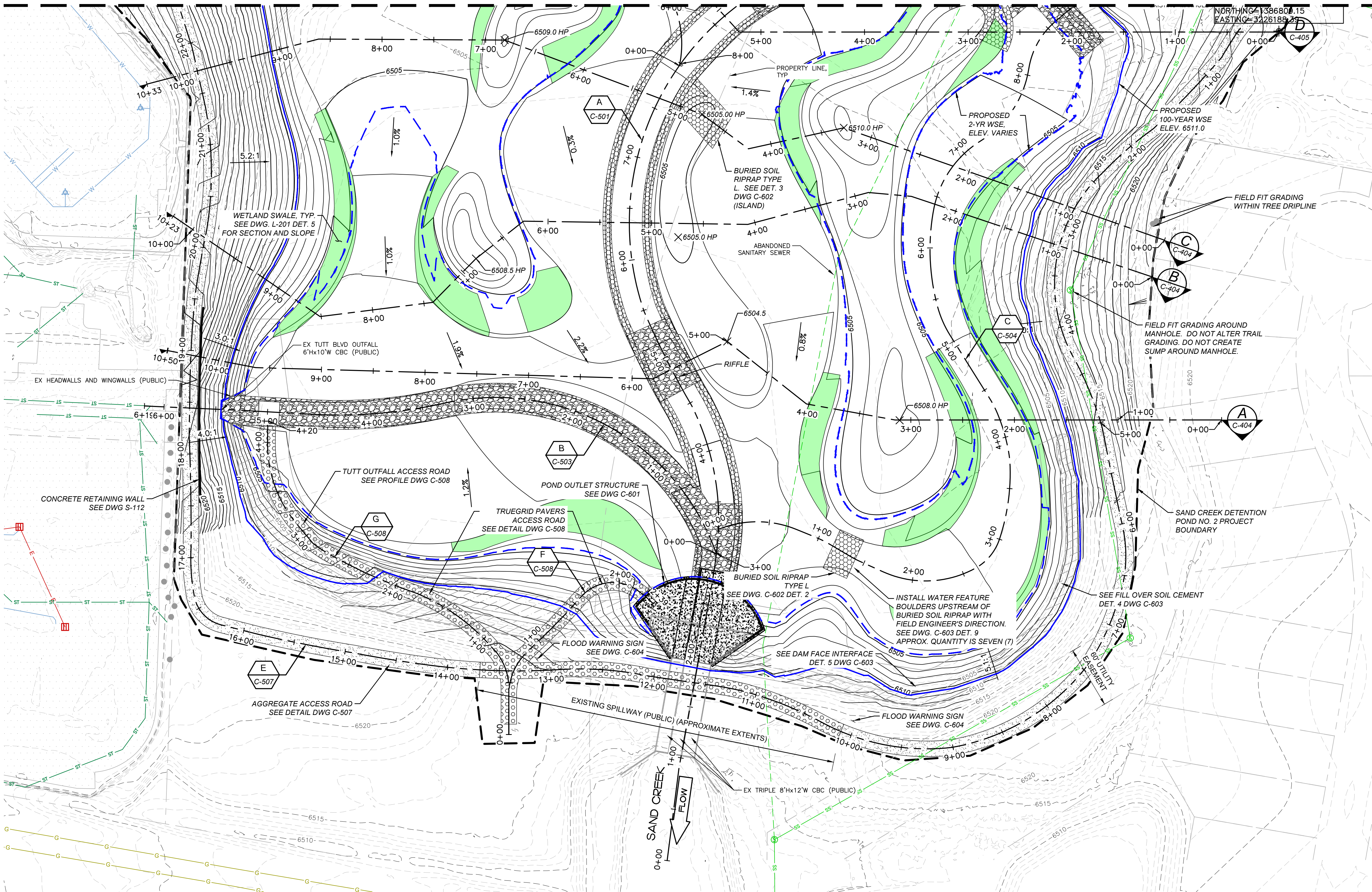

- NOTE:
- SEE LANDSCAPE SHEETS FOR PLANTING PLAN
 - SEE DWG C-603 FOR WATER FEATURE BOULDER DETAIL
 - SEE DWG C-602 FOR RIPRAP DETAILS

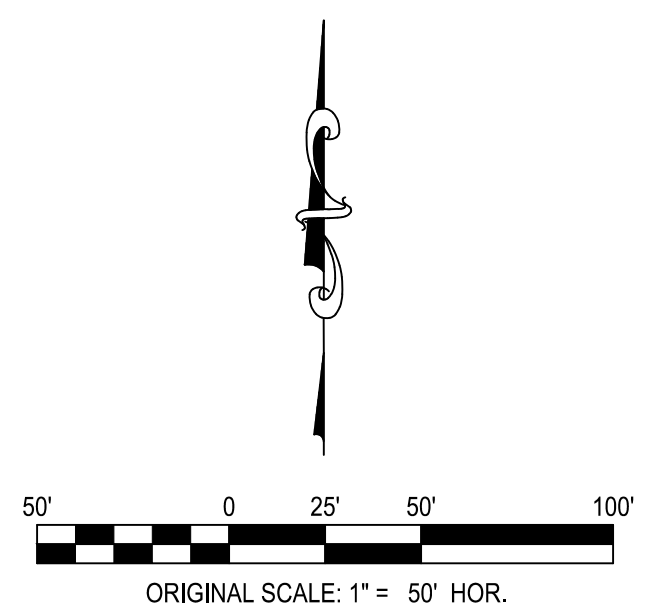

PLAN
SCALE: 1" = 50'

REV	REVISION DESCRIPTION	DATE	CHND	CHKD	APPR

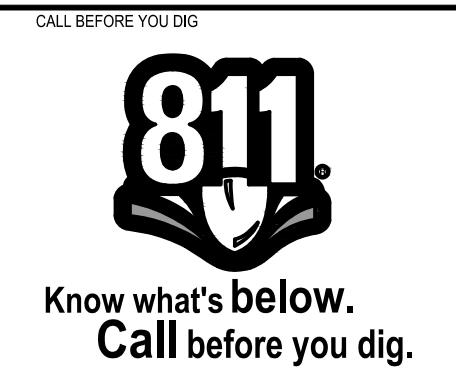

CITY OF COLORADO SPRINGS
 30 S. NEVADA AVE., SUITE 401
 COLORADO SPRINGS, CO 80903
 (719) 385-5980

MERRICK®
 Engineering | Architecture | Design-Build | Surveying | Planning | Geospatial Solutions
 2480 W. 26TH AVE., UNIT B225 - DENVER COLORADO 80211
 TEL. 303-751-0741, FAX 303-751-2581
 www.merrick.com

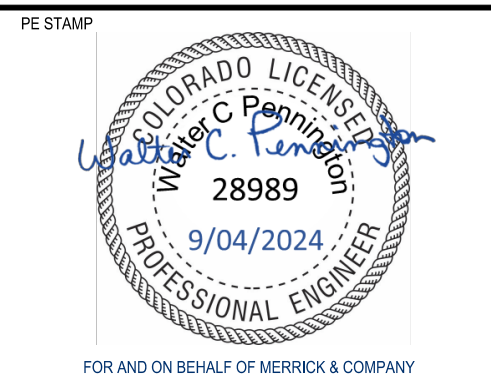

TITLE: **SAND CREEK DETENTION POND NO. 2**
GRADING PLAN (SOUTH)

JOB NUMBER	65420975
DATE	AUGUST 2024
DWG	C-402
SHEET	9 of 51

THE CITY OF COLORADO SPRINGS IS PROVIDING THIS INFORMATION AS AN INSTRUMENT OF SERVICE. SERVICES BY MERRICK AND COMPANY, INC. ARE THE PROPERTY OF MERRICK AND COMPANY, INC. AND ARE NOT TO BE REPRODUCED OR TRANSMITTED IN ANY FORM OR BY ANY MEANS, ELECTRONIC OR MECHANICAL, INCLUDING PHOTOCOPYING, RECORDING, OR BY ANY INFORMATION STORAGE AND RETRIEVAL SYSTEM, WITHOUT THE PRIOR WRITTEN PERMISSION OF MERRICK AND COMPANY, INC. THIS INFORMATION IS PROVIDED AS IS AND WITHOUT WARRANTY OF ANY KIND, EXPRESS OR IMPLIED, INCLUDING BUT NOT LIMITED TO THE WARRANTIES OF MERCHANTABILITY, FITNESS FOR A PARTICULAR PURPOSE, AND NONINFRINGEMENT OF THIRD PARTY RIGHTS. ALL RIGHTS RESERVED.

File Location: D:\Denver_North\Projects\City of Colorado Springs\Sand Creek Pond No. 2\CAD\CDS\0975-SITE_PLAN.dwg Pklt Date: 9/4/2024 10:59 AM Last Saved By: TIM.MCKMULLEN

NOTE: DO NOT FILL OVER SOIL CEMENT. CONTACT OWNER'S REPRESENTATIVE IF EX. SOIL CEMENT IS 0.5' LOWER THAN PROPOSED GRADE.

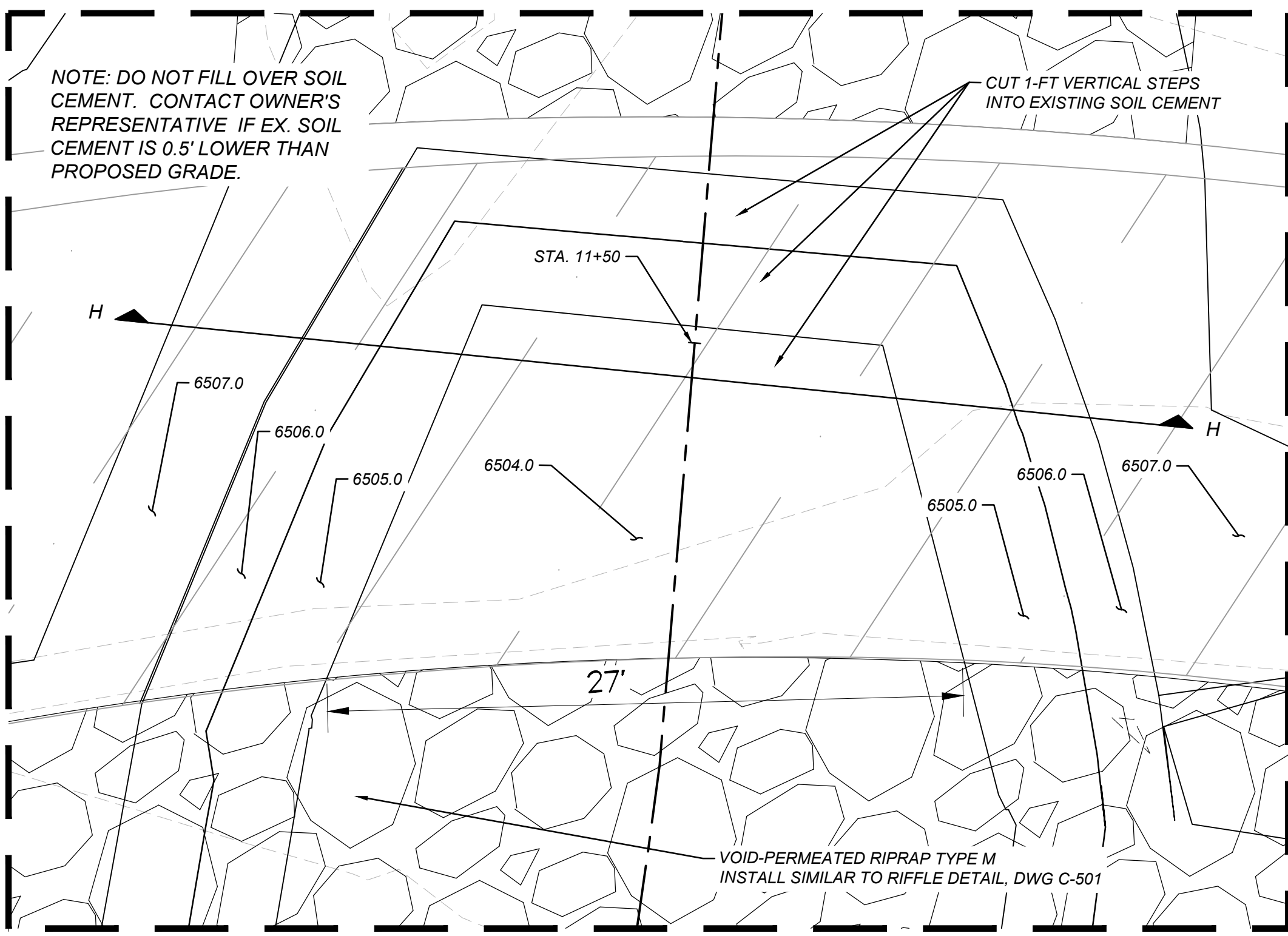

SOIL CEMENT MODIFICATION PLAN ENLARGEMENT
SCALE: 1" = 5'

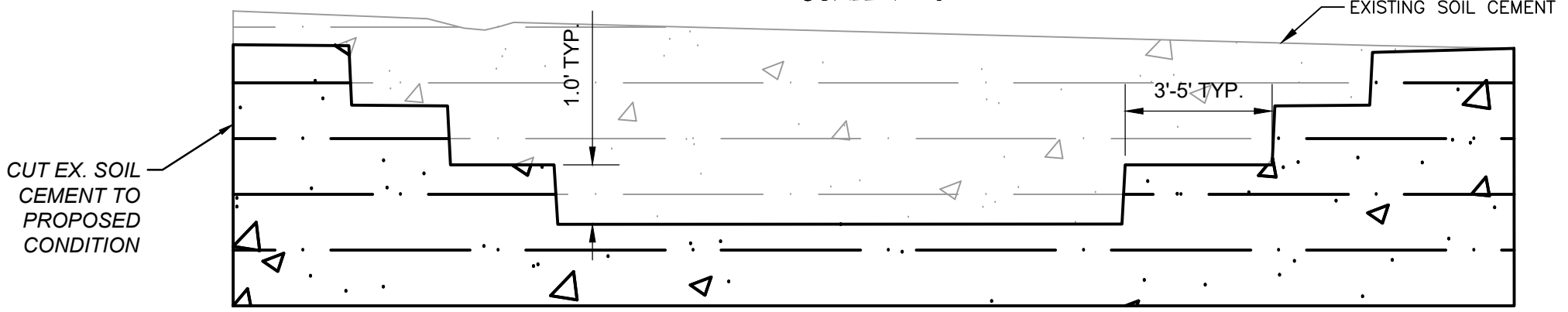

SOIL CEMENT MODIFICATION SECTION H-H (NTS)

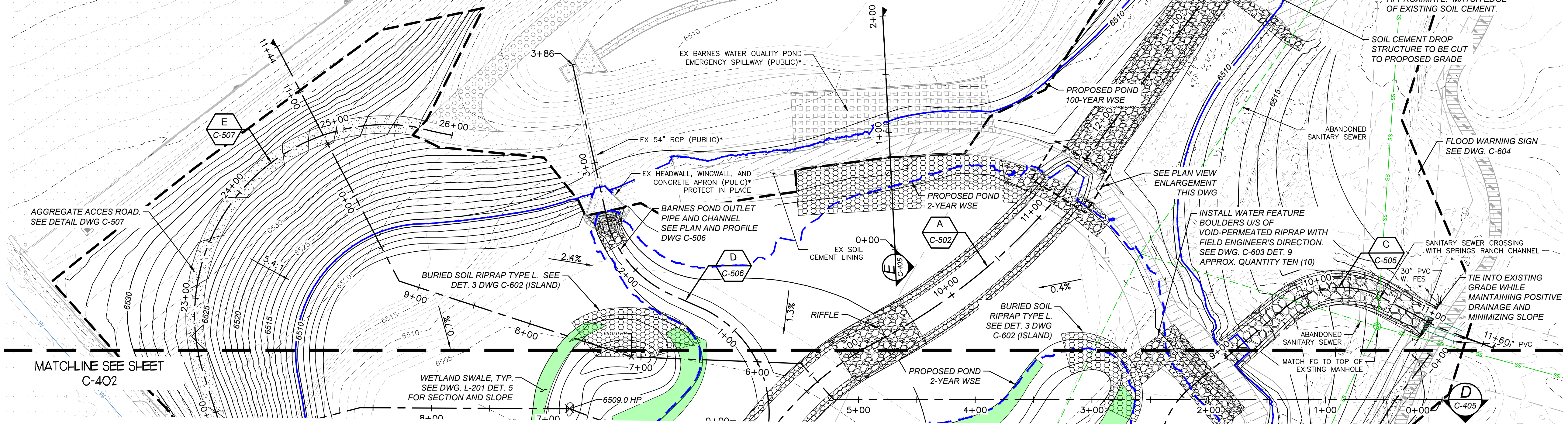
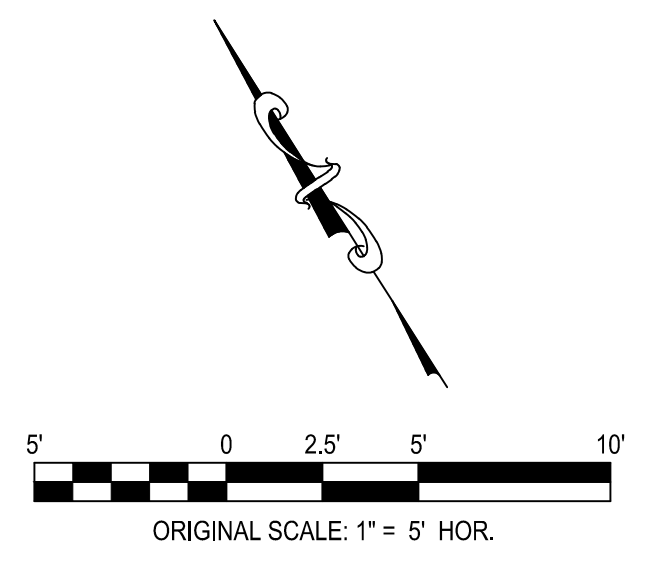

PLAN
SCALE: 1" = 50'

- NOTE:
1. SEE LANDSCAPE SHEETS FOR PLANTING PLAN
 2. SEE DWG C-603 FOR WATER FEATURE BOULDER DETAIL
 3. SEE DWG C-602 FOR RIPRAP DETAILS

*THIS INFRASTRUCTURE ELEMENT IS PROPOSED AS PART OF THE BARNES WATER QUALITY POND PROJECT, WHICH IS TO BE COMPLETED BEFORE CONSTRUCTION OF SAND CREEK POND NO. 2 RESTORATION BEGINS.

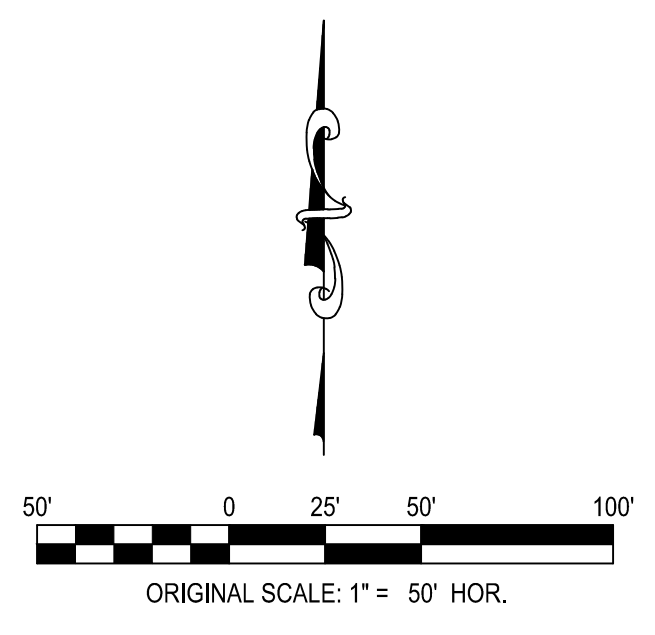

REV	REVISION DESCRIPTION	DATE	CHND	CHKD	APPR

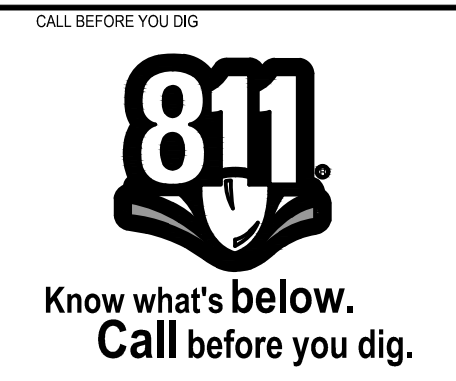

CITY OF COLORADO SPRINGS
30 S. NEVADA AVE., SUITE 401
COLORADO SPRINGS, CO 80903
(719) 385-5980

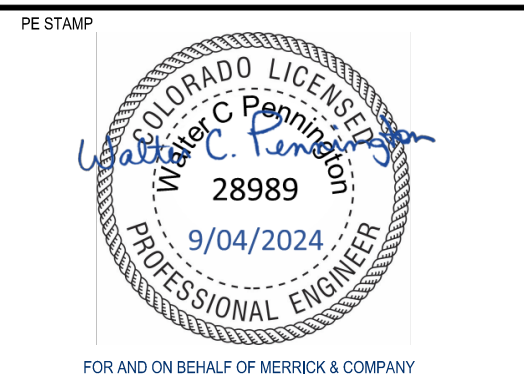

TITLE
SAND CREEK DETENTION POND NO. 2
GRADING PLAN (NORTH)

JOB NUMBER	65420975
DATE	AUGUST 2024
DWG	C-403
SHEET	10 of 51

THE CITY OF COLORADO SPRINGS IS PROVIDING THIS INFORMATION AS AN INSTRUMENT OF SERVICE. SERVICES BY MERRICK AND COMPANY, INC. ARE PROVIDED AS AN INSTRUMENT OF SERVICE. IT IS NOT INTENDED OR REPRESENTED TO BE A FINAL DESIGN OR PART OF A PERMITTING PROCESS. THE USER SHALL BE RESPONSIBLE FOR OBTAINING ALL NECESSARY PERMITS AND APPROVALS FROM THE APPROPRIATE AGENCIES. MERRICK AND COMPANY, INC. SHALL NOT BE RESPONSIBLE FOR ANY ERRORS OR OMISSIONS.

File Location: D:\Denver_North\Projects\City of Colorado Springs\Sand Creek Pond No 2\CAD\CDS\0975-SITE_PLAN.dwg Pk1 Date: 8/26/2024 4:31 PM Last Saved By: TIM.MCWHULLEN

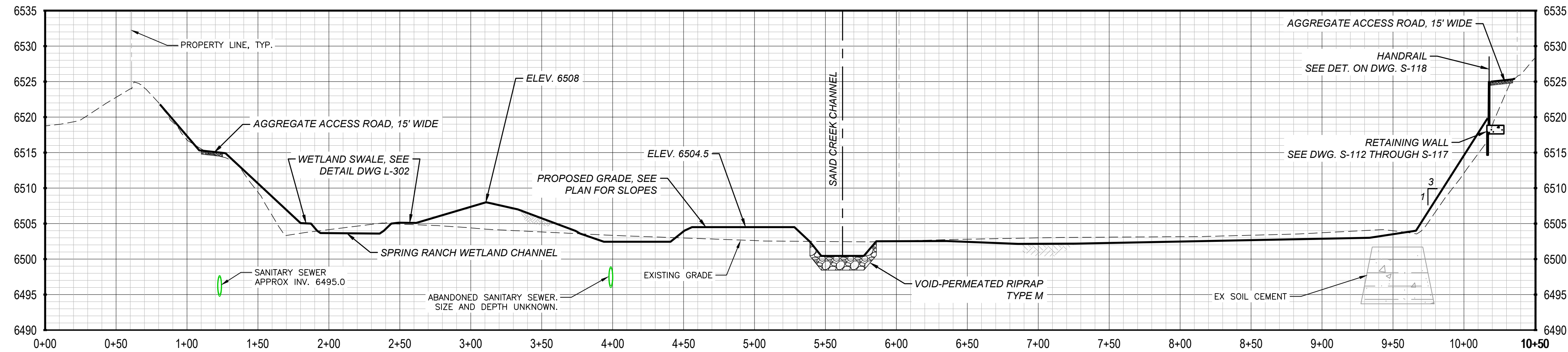

SECTION A
 HOR. SCALE: 1" = 50'
 VER. SCALE: 1" = 10'

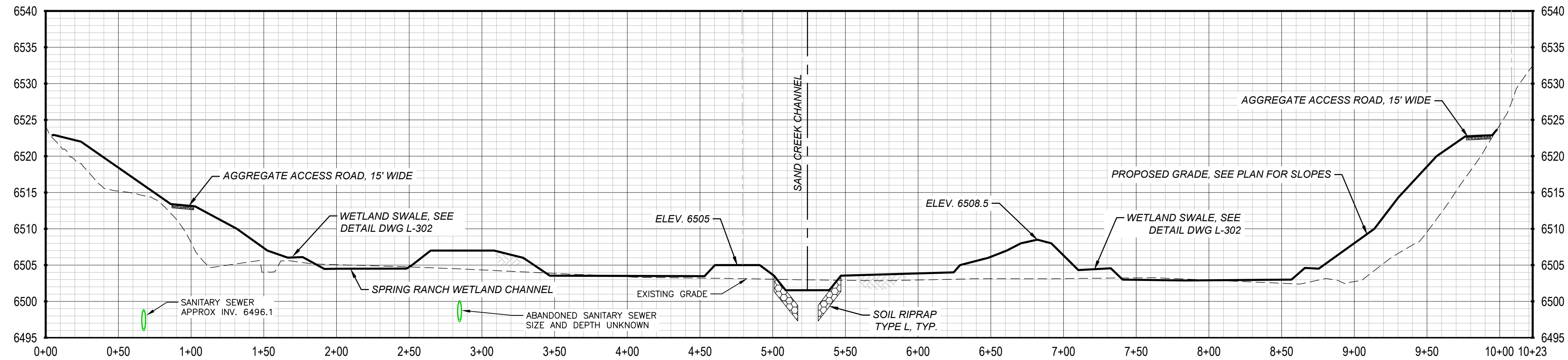

SECTION B
 HOR. SCALE: 1" = 50'
 VER. SCALE: 1" = 10'

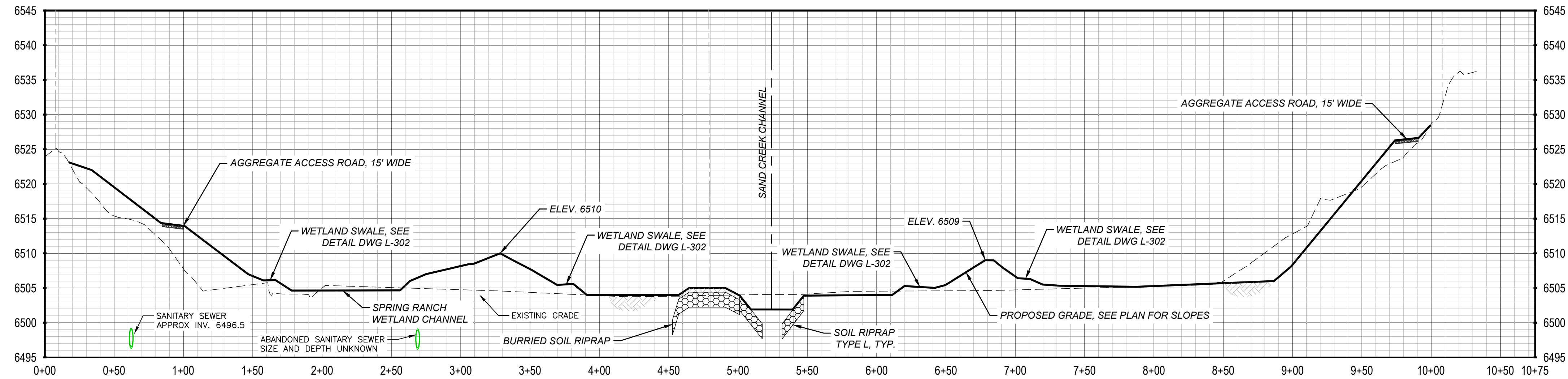

SECTION C
 HOR. SCALE: 1" = 50'
 VER. SCALE: 1" = 10'

ALL SECTIONS LOOKING DOWNSTREAM

REV	REVISION DESCRIPTION	DATE	CHND	CHKD	APPR



CITY OF COLORADO SPRINGS
 30 S. NEVADA AVE., SUITE 401
 COLORADO SPRINGS, CO 80903
 (719) 385-5980

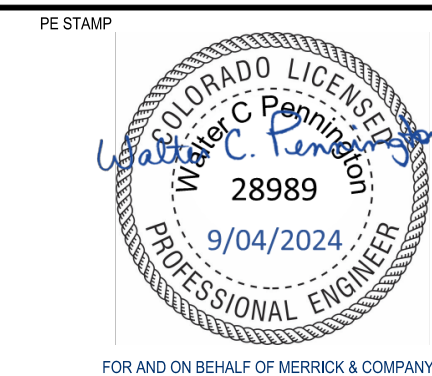

SAND CREEK DETENTION POND NO. 2

POND SECTIONS

JOB NUMBER	65420975
DATE	AUGUST 2024
DWG	C-404
SHEET	11 of 51

THE CITY OF COLORADO SPRINGS IS PROVIDING THIS INFORMATION AS AN INSTRUMENT OF SERVICE. SERVICES BY MERRICK AND COMPANY, FOR A FEE, ARE PROVIDED AS AN INSTRUMENT OF SERVICE. MERRICK AND COMPANY IS NOT PROVIDING ANY GUARANTEE OR WARRANTY FOR THE PROJECT OR FOR ANY OTHER PROJECT. IT IS NOT INTENDED OR REPRESENTED TO BE A BASIS FOR REUSE OR FOR REUSE IN WHOLE OR IN PART FOR ANY OTHER PROJECT OR FOR ANY OTHER PROJECT. MERRICK AND COMPANY SHALL BE AT THE SOLE RISK FOR THE QUALITY OF ANY REUSE OR FOR REUSE IN WHOLE OR IN PART FOR ANY OTHER PROJECT OR FOR ANY OTHER PROJECT.

File Location: D:\Denver_North\Projects\City of Colorado Springs\Sand Creek Pond No. 2\CAD\09\0975-SITE_PLAN.dwg Pk1 Date: 8/26/2024 4:31 PM Last Saved By: TIM.MCMULLEN

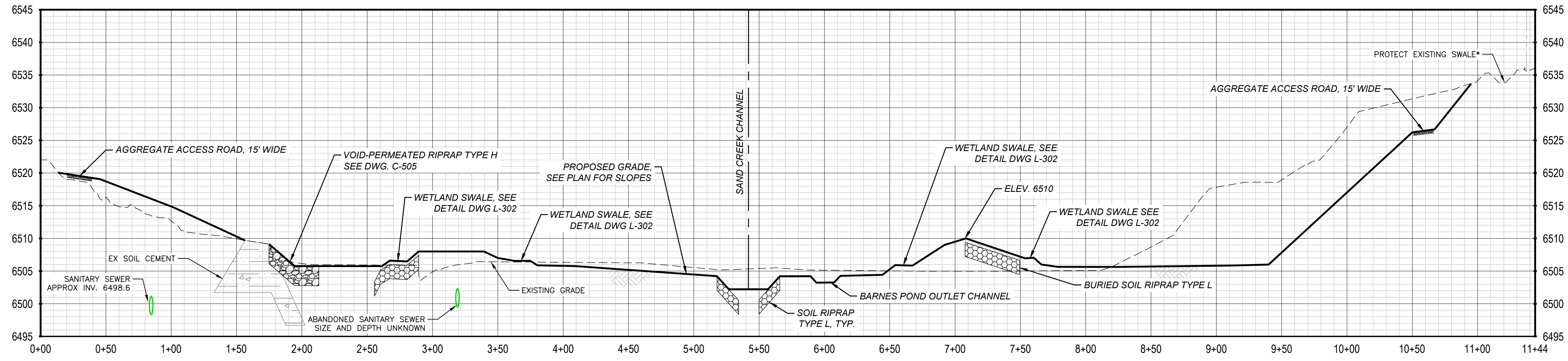

SECTION D
 HOR. SCALE: 1" = 50'
 VER. SCALE: 1" = 10'

*THIS INFRASTRUCTURE ELEMENT IS PROPOSED AS PART OF THE BARNES WATER QUALITY POND PROJECT, WHICH IS TO BE COMPLETED BEFORE CONSTRUCTION OF SAND CREEK POND NO. 2 RESTORATION BEGINS.

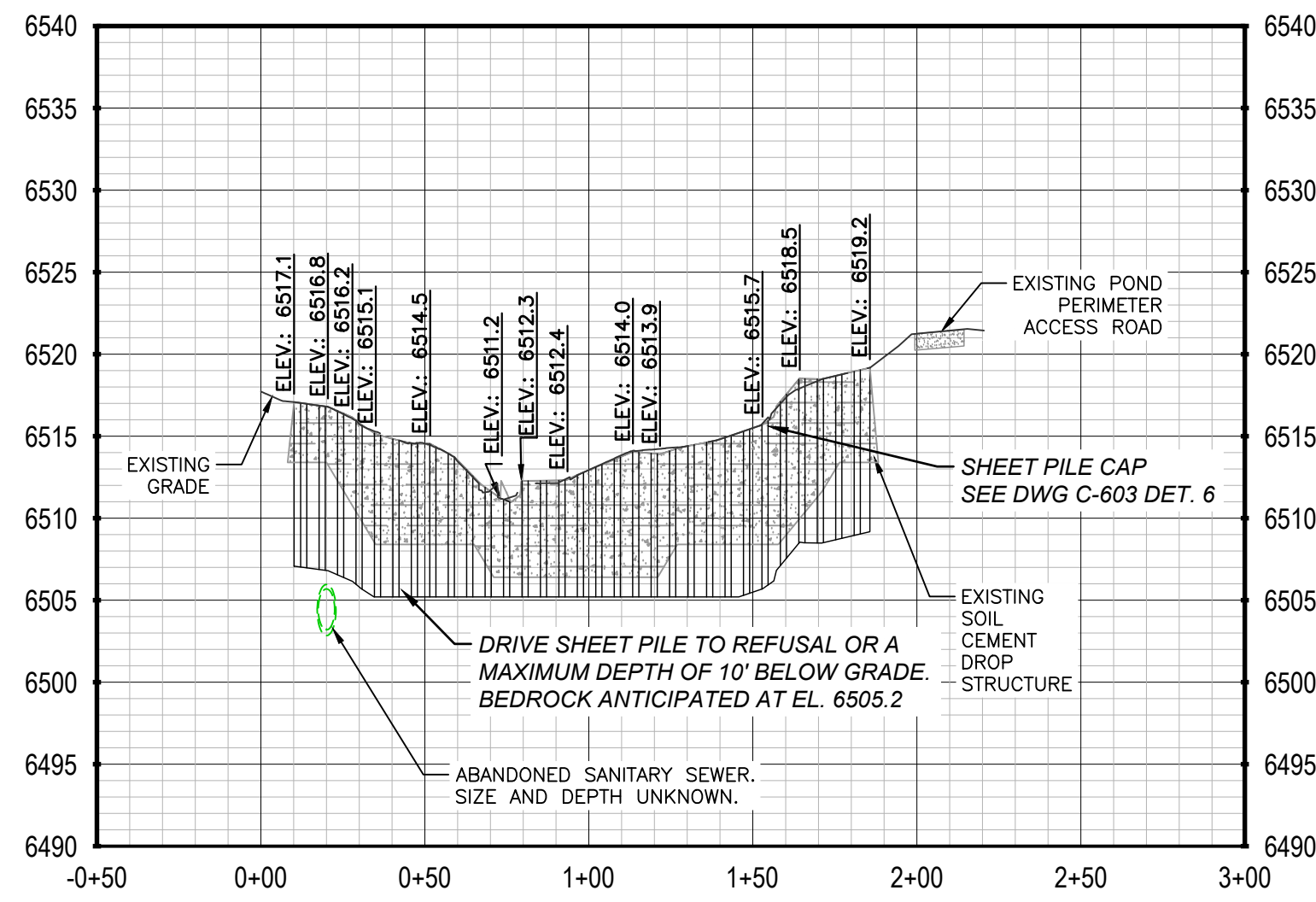

SECTION F
 HOR. SCALE: 1" = 30'
 VER. SCALE: 1" = 5'

NOTE: CREST ELEVATIONS ARE APPROXIMATE. MATCH EXISTING GRADE.

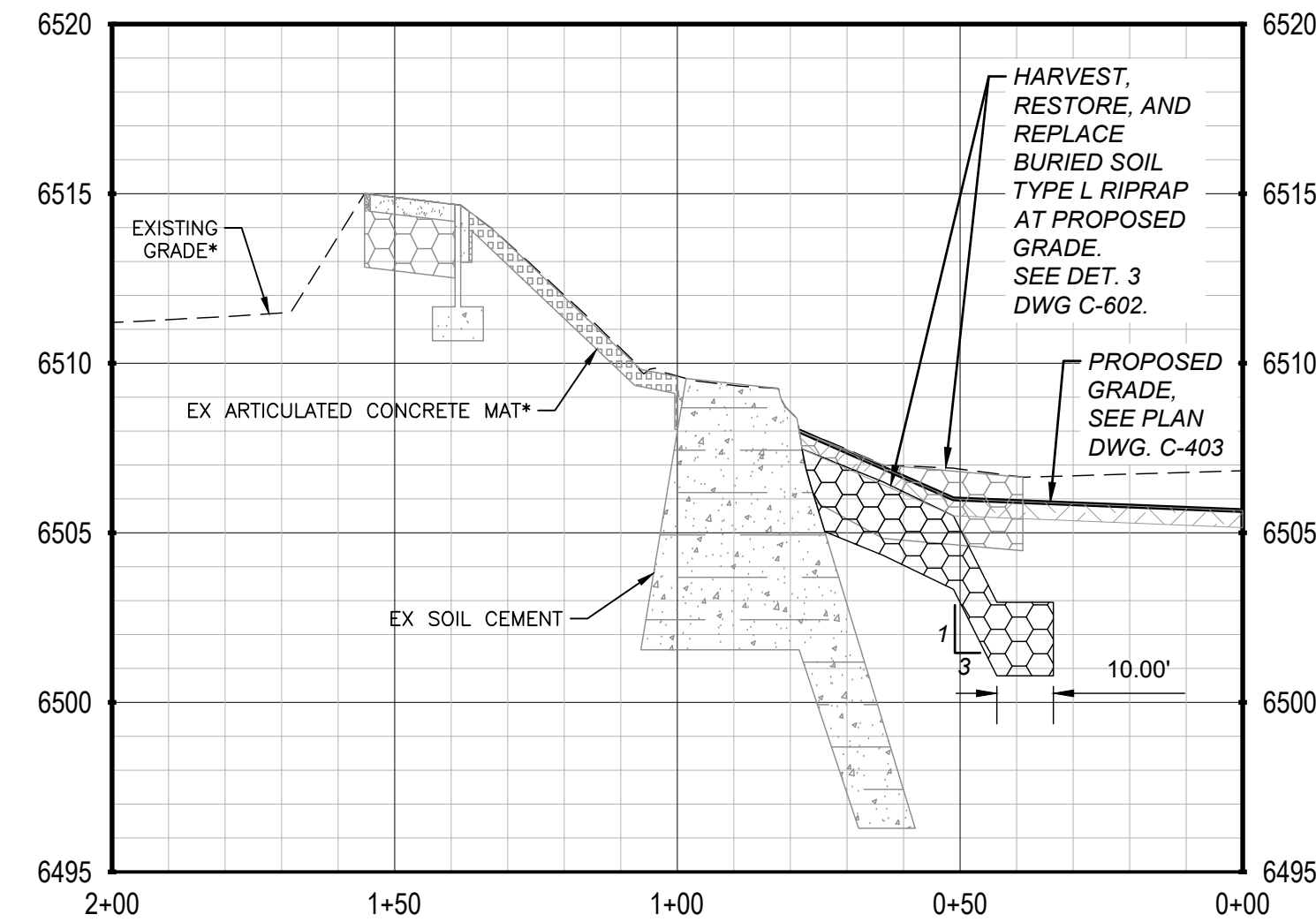

SECTION E
 HOR. SCALE: 1" = 30'
 VER. SCALE: 1" = 5'

REV	REVISION DESCRIPTION	DATE	CHND	CHKD	APPR

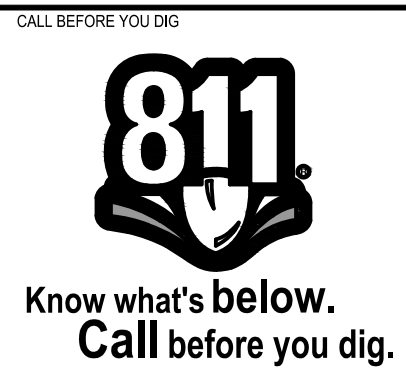

CITY OF COLORADO SPRINGS
 30 S. NEVADA AVE., SUITE 401
 COLORADO SPRINGS, CO 80903
 (719) 385-5980

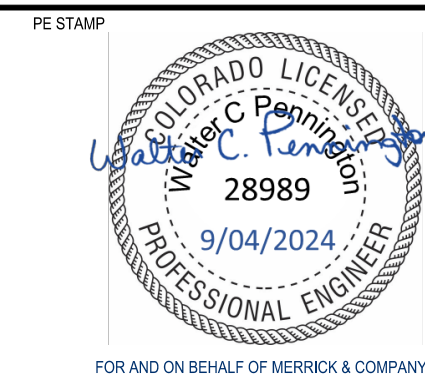

TITLE: SAND CREEK DETENTION POND NO. 2
 POND SECTIONS

JOB NUMBER	65420975
DATE	AUGUST 2024
DWG	C-405
SHEET	12 of 51

THE CITY OF COLORADO SPRINGS HAS REVIEWED THIS PLAN AND SPECIFICATIONS FOR CONFORMANCE WITH THE CITY ENGINEERING DEPARTMENT'S STANDARDS AND SPECIFICATIONS FOR SANITARY SEWERAGE. THE CITY ENGINEERING DEPARTMENT'S REVIEW IS LIMITED TO THE TECHNICAL ASPECTS OF THE PROJECT AND DOES NOT CONSTITUTE AN ENDORSEMENT OF THE PROJECT OR AN ASSURANCE OF THE ACCURACY OF THE INFORMATION PROVIDED HEREON. THE CITY ENGINEERING DEPARTMENT'S REVIEW IS LIMITED TO THE TECHNICAL ASPECTS OF THE PROJECT AND DOES NOT CONSTITUTE AN ENDORSEMENT OF THE PROJECT OR AN ASSURANCE OF THE ACCURACY OF THE INFORMATION PROVIDED HEREON. THE CITY ENGINEERING DEPARTMENT'S REVIEW IS LIMITED TO THE TECHNICAL ASPECTS OF THE PROJECT AND DOES NOT CONSTITUTE AN ENDORSEMENT OF THE PROJECT OR AN ASSURANCE OF THE ACCURACY OF THE INFORMATION PROVIDED HEREON.

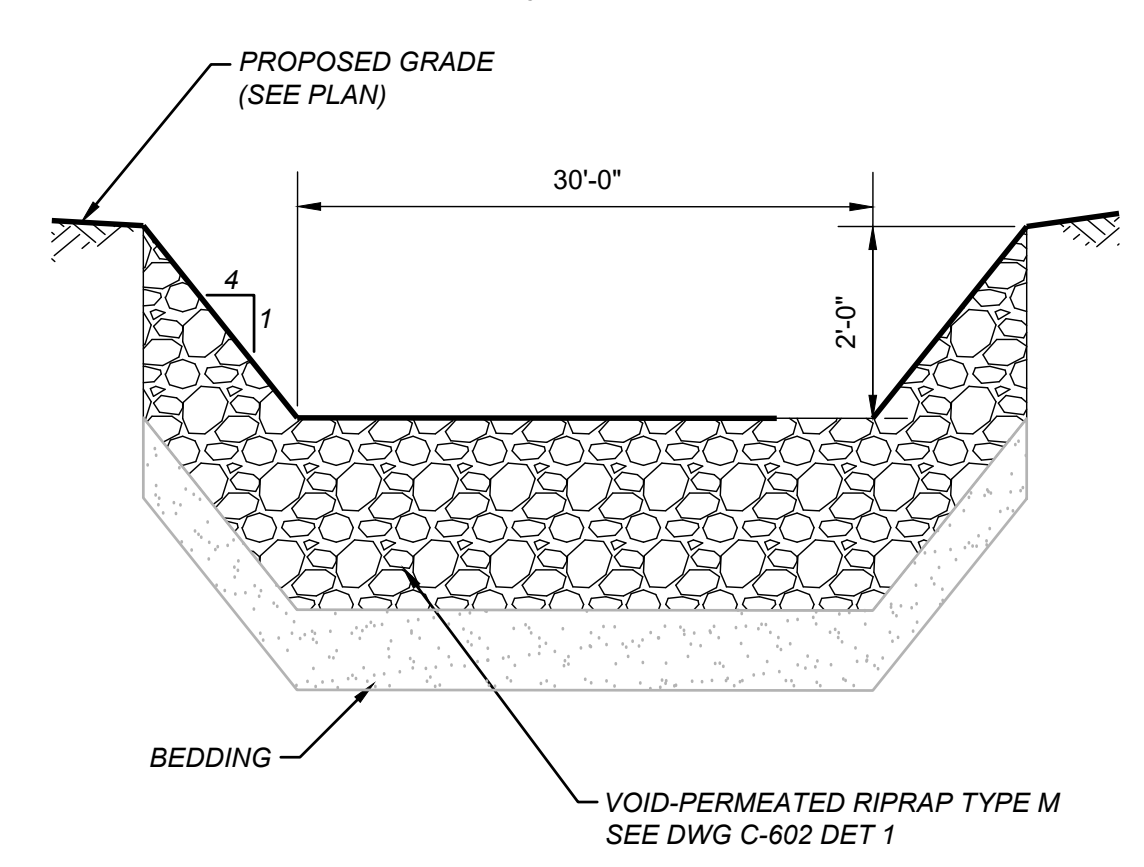
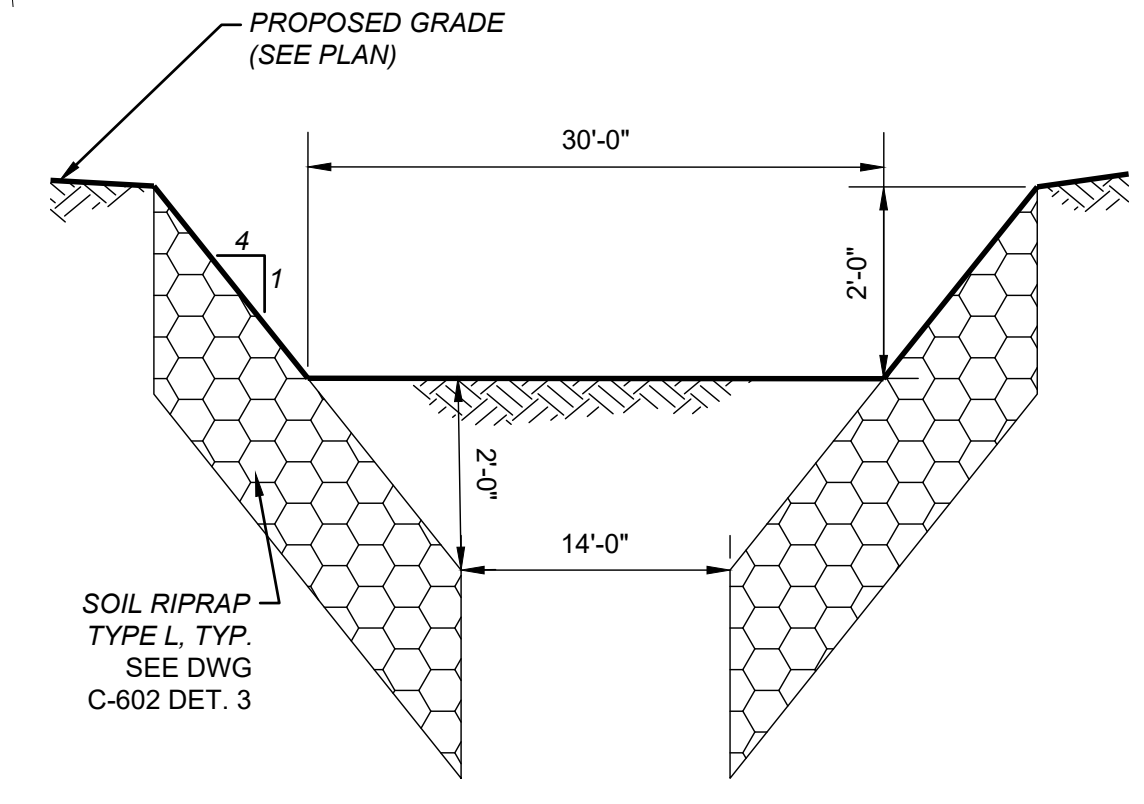
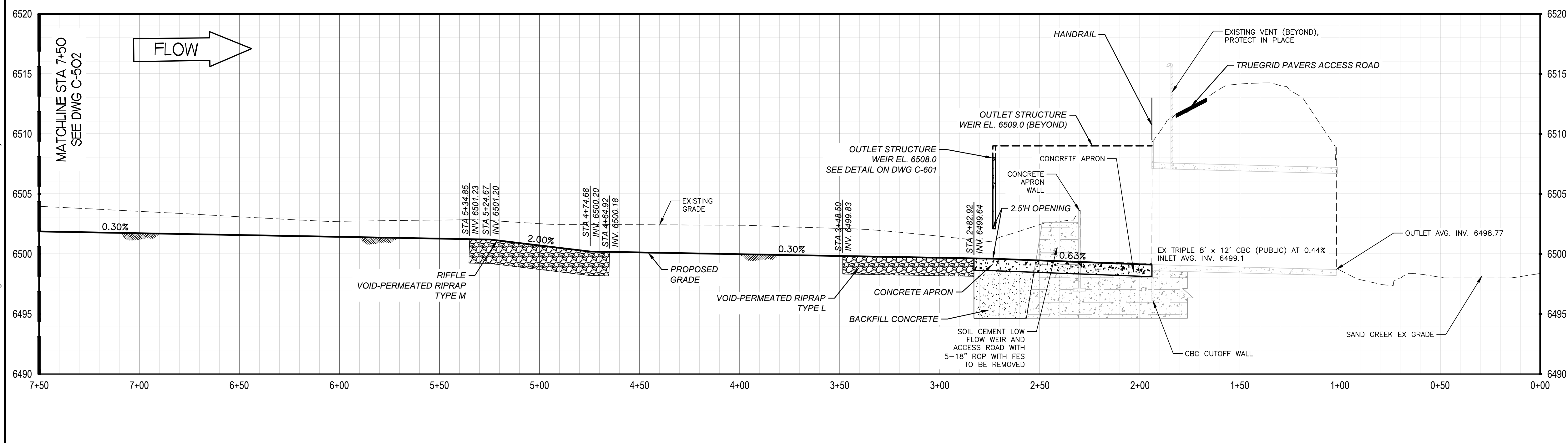
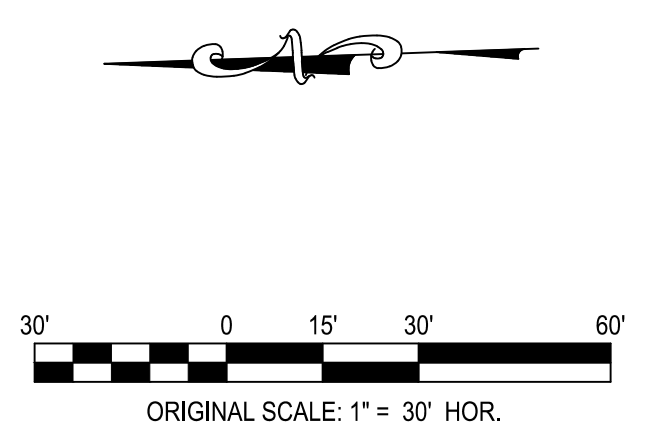
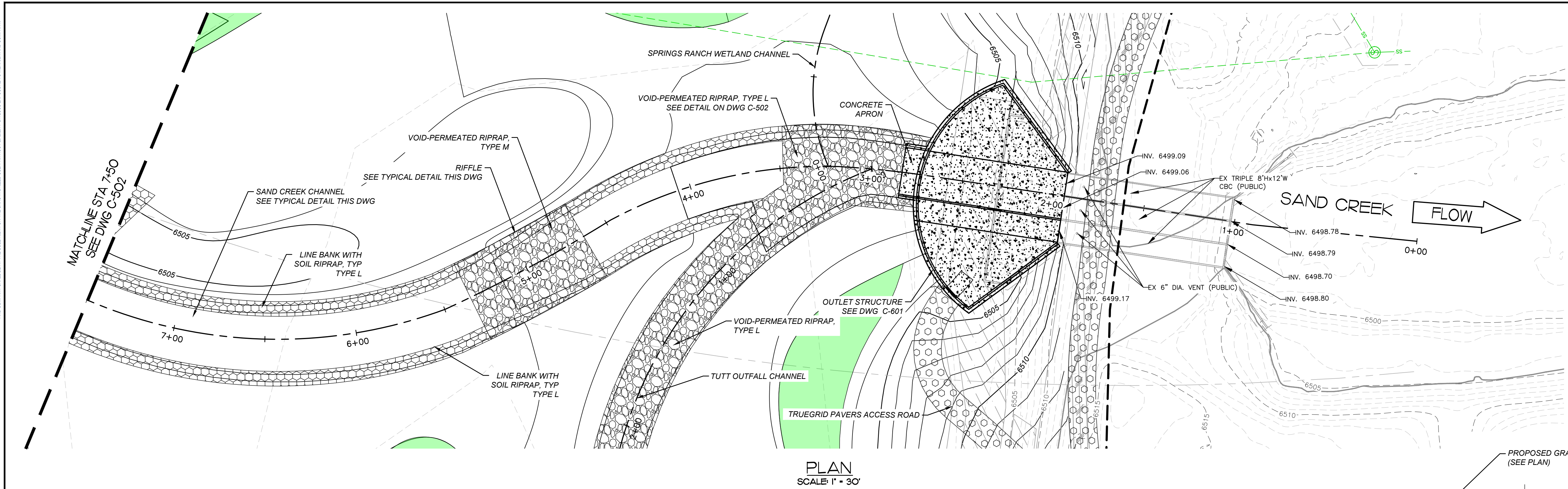

REV	REVISION DESCRIPTION	DATE	CHND	CHKD	APPR

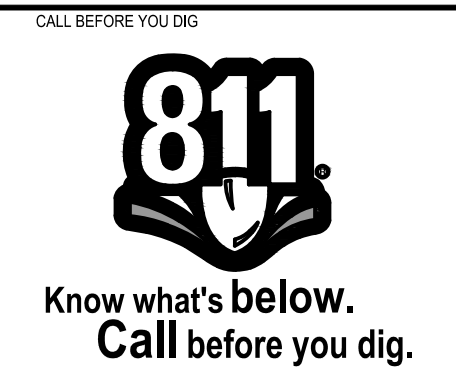

CITY OF COLORADO SPRINGS
 30 S. NEVADA AVE., SUITE 401
 COLORADO SPRINGS, CO 80903
 (719) 385-5980



SAND CREEK DETENTION POND NO. 2
SAND CREEK CHANNEL PLAN & PROFILE
 STA 0+00 TO STA. 7+50

JOB NUMBER	65420975
DATE	AUGUST 2024
DWG	C-501
SHEET	13 of 51

THE CITY OF COLORADO SPRINGS IS PROVIDING THIS INFORMATION AS A SERVICE TO THE PUBLIC. IT IS NOT INTENDED OR REPRESENTED TO BE A SUBSTITUTE FOR PROFESSIONAL ENGINEERING OR ARCHITECTURAL SERVICES. THE CITY OF COLORADO SPRINGS DOES NOT WARRANT THE ACCURACY, COMPLETENESS, OR QUALITY OF ANY INFORMATION PROVIDED HEREIN. THE CITY OF COLORADO SPRINGS DOES NOT ASSUME ANY LIABILITY FOR ANY DAMAGE TO PERSONS OR PROPERTY, INCLUDING BUT NOT LIMITED TO, CONSEQUENTIAL DAMAGES, ARISING FROM THE USE OF THIS INFORMATION.

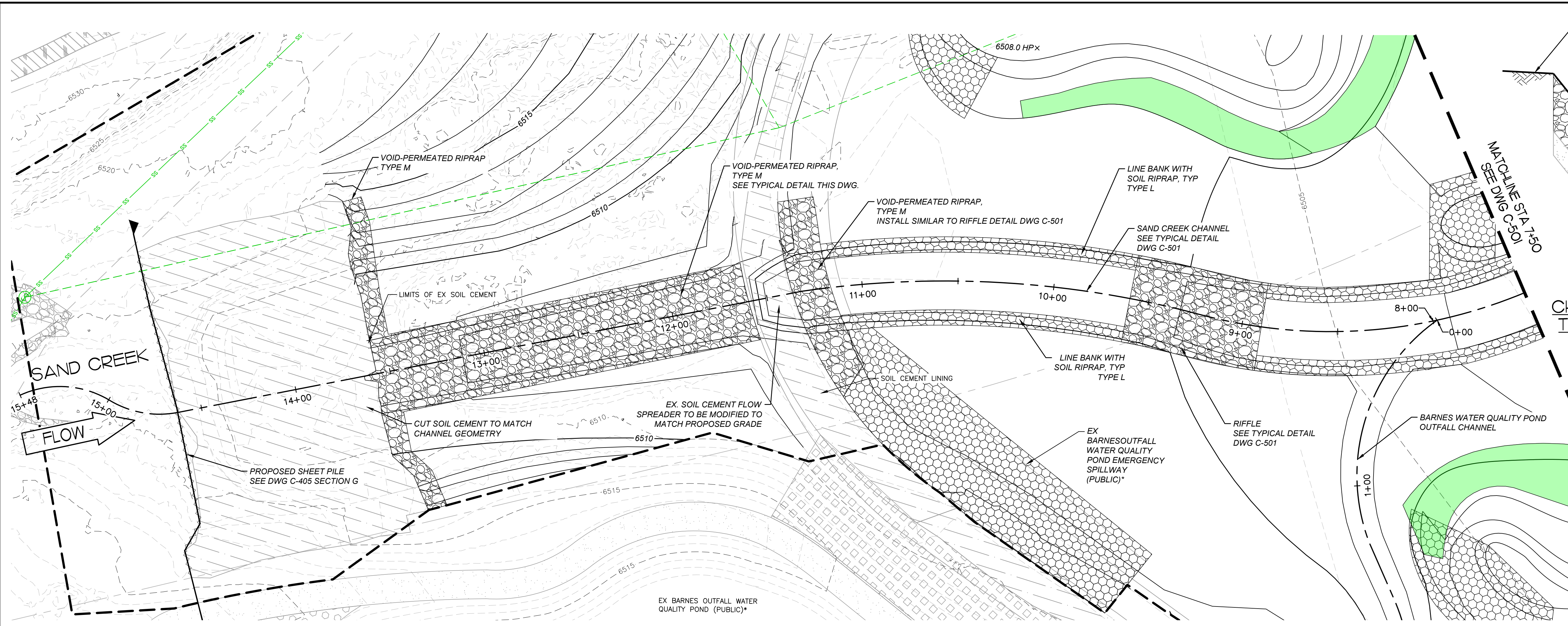

TYPICAL SAND CREEK CHANNEL SECTION STA. 2+83 TO 3+49 AND 11+58 TO 13+68
 HOR. SCALE: 1" = 10'
 VER. SCALE: 1" = 2'

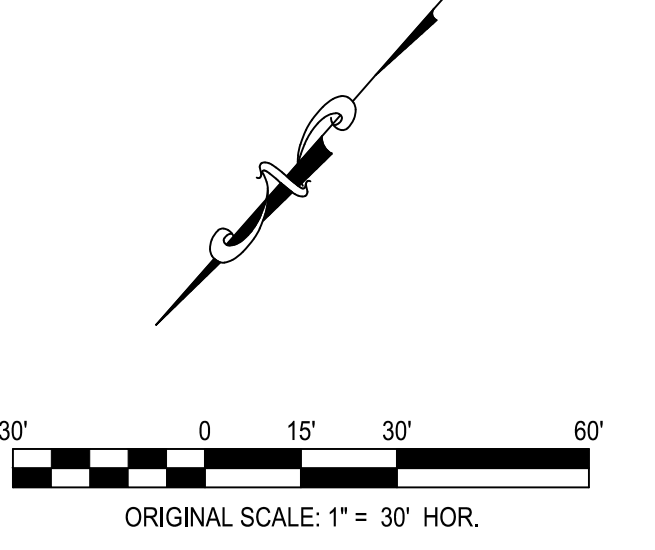
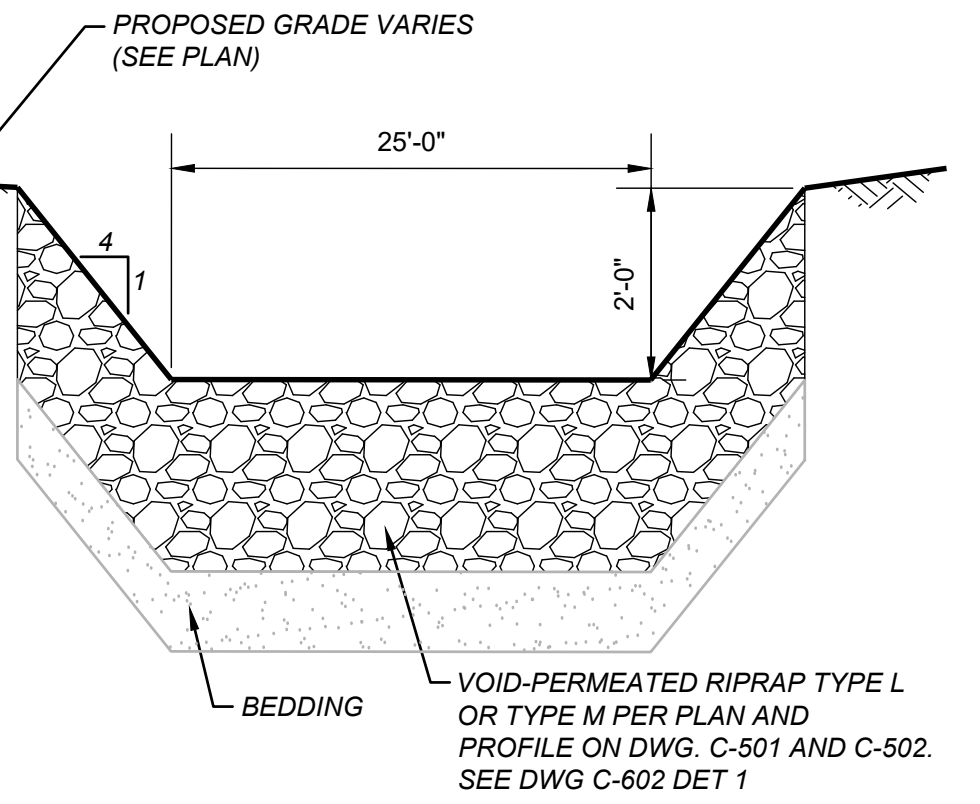

PLAN
 SCALE: 1" = 30'

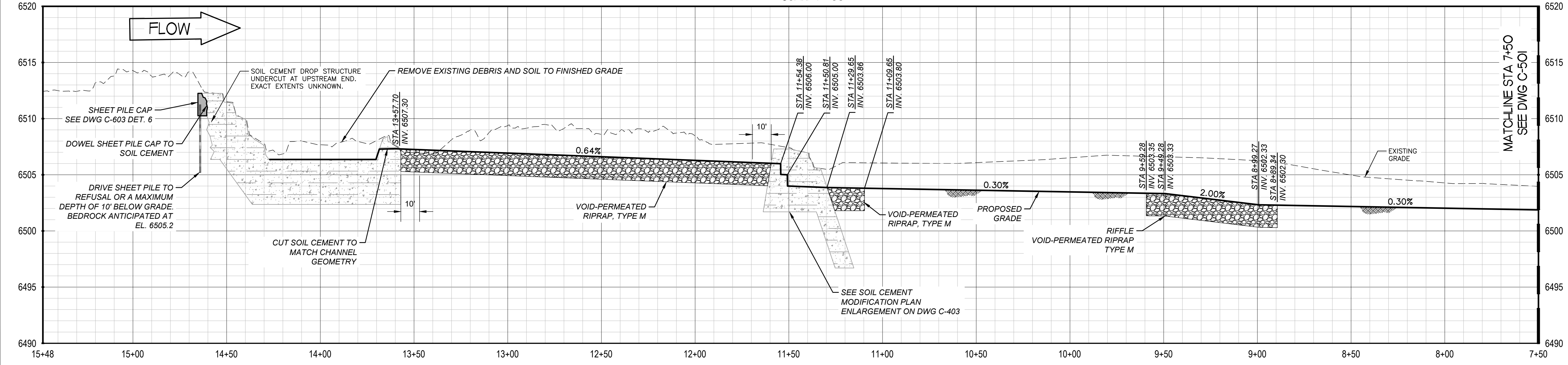

*THIS INFRASTRUCTURE ELEMENT IS PROPOSED AS PART OF THE BARNES WATER QUALITY POND PROJECT, WHICH IS TO BE COMPLETED BEFORE CONSTRUCTION OF SAND CREEK POND NO. 2 RESTORATION BEGINS.

A PROFILE
 C-502 HOR. SCALE: 1" = 30'
 VER. SCALE: 1" = 5'

File Location: D:\Denver_North\Projects\City of Colorado Springs\Sand Creek Pond No. 2\CAD\C502\0975-P&P.dwg Plot Date: 8/26/2024 4:33 PM Last Saved By: TIM.MCMULLEN R24-1285

REV	REVISION DESCRIPTION	DATE	CHND	CHKD	APPR

CALL BEFORE YOU DIG

 Know what's below.
 Call before you dig.

CITY OF COLORADO SPRINGS
 30 S. NEVADA AVE., SUITE 401
 COLORADO SPRINGS, CO 80903
 (719) 385-5980

MERRICK
 Engineering | Architecture | Design-Build | Surveying | Planning | Geospatial Solutions
 2480 W. 26TH AVE., UNIT B225 - DENVER COLORADO 80211
 TEL. 303-751-0741, FAX 303-751-2581
 www.merrick.com

PE STAMP

 FOR AND ON BEHALF OF MERRICK & COMPANY

TITLE
SAND CREEK DETENTION POND NO. 2
SAND CREEK CHANNEL PLAN & PROFILE
 STA. 7+50 TO STA. 15+45

JOB NUMBER: 65420975
 DATE: AUGUST 2024
 DWG: **C-502**
 SHEET: 14 of 51

THE CITY OF COLORADO SPRINGS IS PROVIDING THIS INFORMATION AS AN INSTRUMENT OF SERVICE. MERRICK & COMPANY, INC. IS THE ENGINEER OF RECORD FOR THIS PROJECT. IT IS NOT INTENDED OR REPRESENTED TO BE SUITABLE FOR REUSE OR FOR REUSE IN WHOLE OR IN PART FOR ANY OTHER PROJECT WITHOUT THE WRITTEN CONSENT OF MERRICK & COMPANY, INC. THE USER SHALL BE RESPONSIBLE FOR OBTAINING ALL NECESSARY PERMITS AND APPROVALS FROM THE APPROPRIATE AGENCIES.



PLAN
SCALE: 1" = 30'

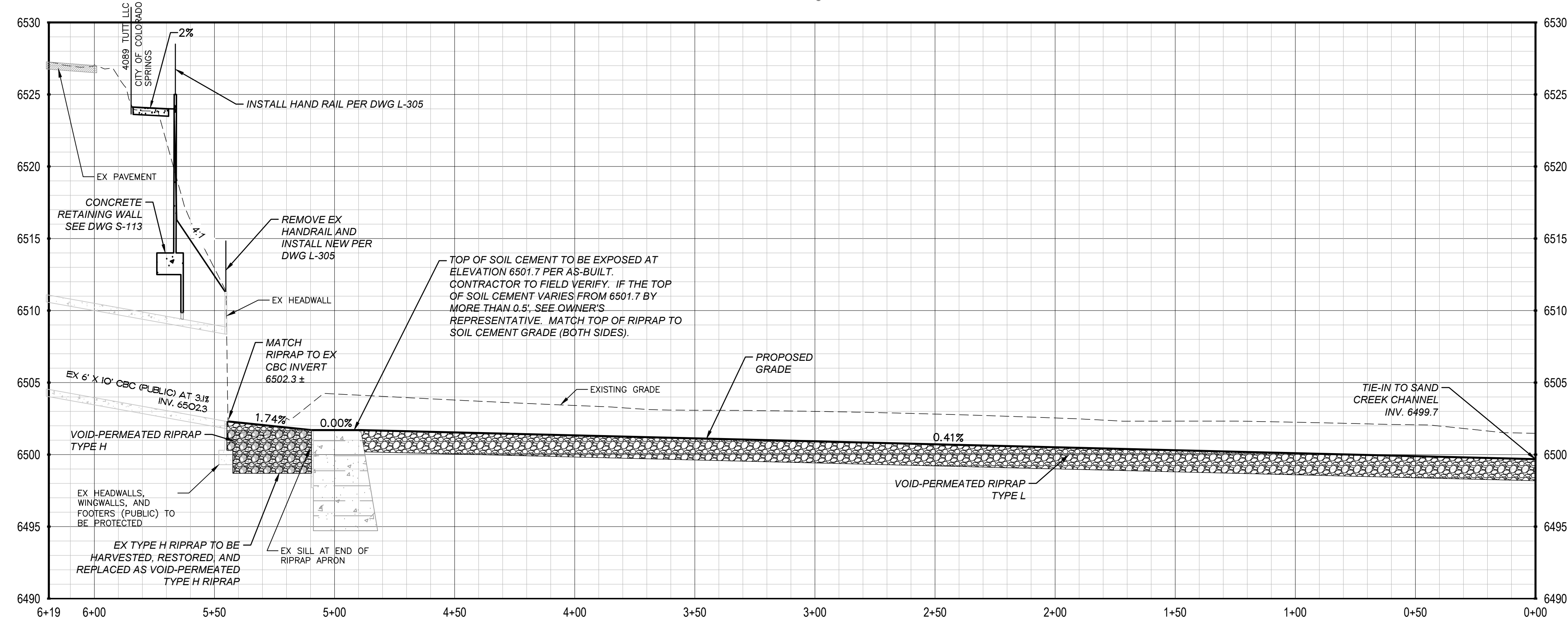

B PROFILE
C-503 HOR. SCALE: 1" = 30'
VER. SCALE: 1" = 5'

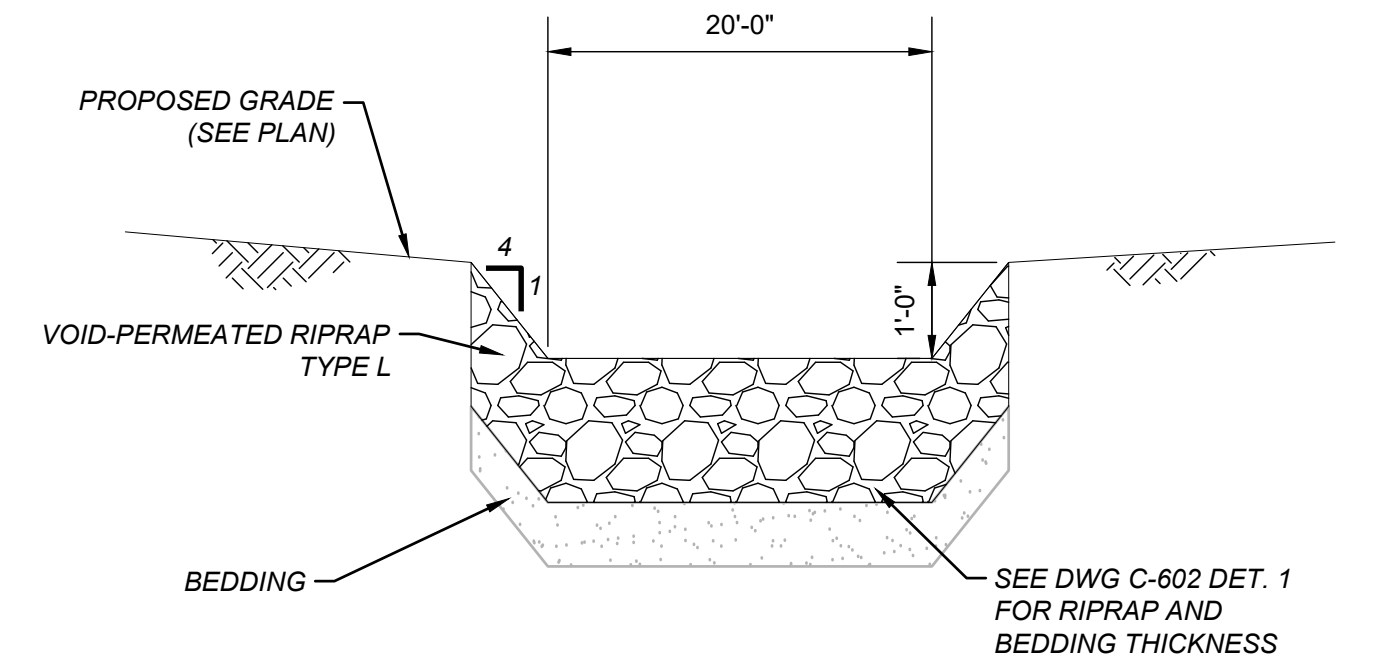

TUTT OUTFALL CHANNEL
TYPICAL SECTION

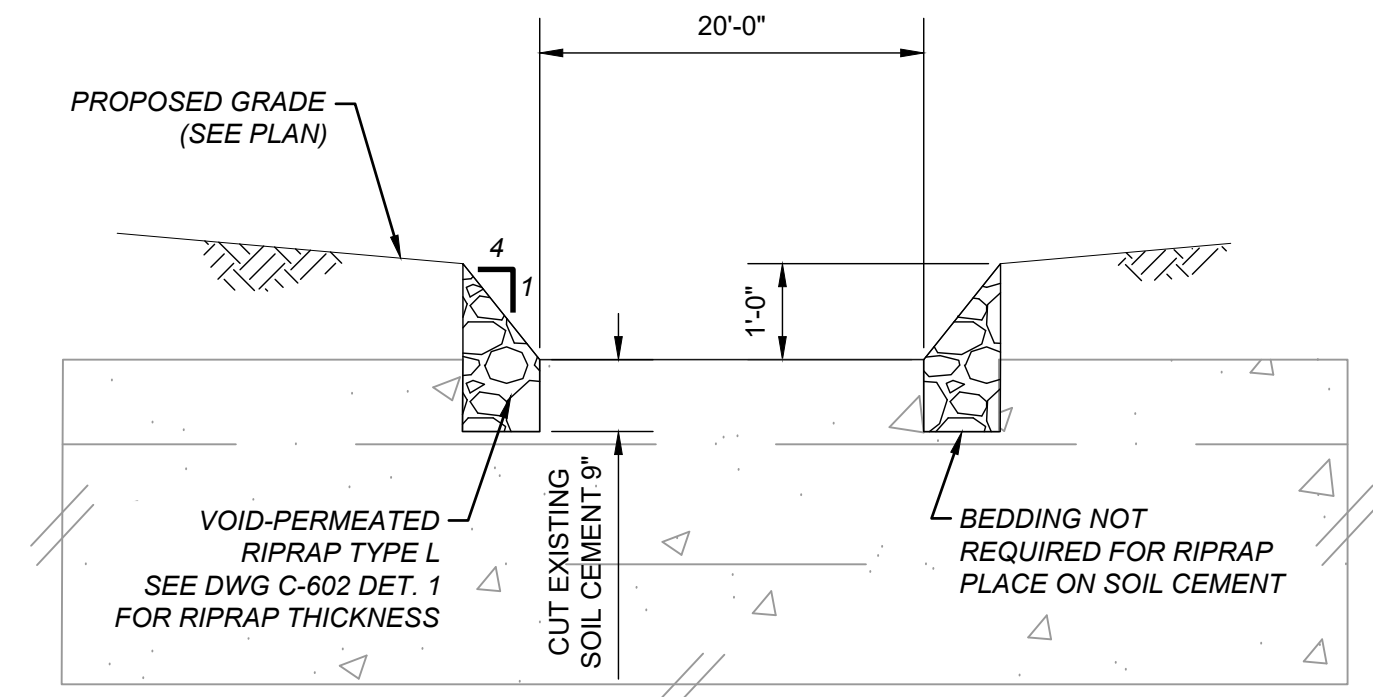

TUTT OUTFALL CHANNEL
TYPICAL SECTION OVER SOIL CEMENT
APPROX STA. 4+89 TO 5+09
HOR. SCALE: 1" = 10'
VER. SCALE: 1" = 2'

File Location: D:\Denver_North\Projects\City of Colorado Springs\Sand Creek Pond No. 2\CAD\CDS\0975-Tutt-P&P.dwg Plot Date: 8/26/2024 4:34 PM Last Saved By: TIM MCMULLEN

REV	REVISION DESCRIPTION	DATE	CHND	CHKD	APPR



CITY OF COLORADO SPRINGS
30 S. NEVADA AVE., SUITE 401
COLORADO SPRINGS, CO 80903
(719) 385-5980



TITLE: SAND CREEK DETENTION POND NO. 2
TUTT OUTFALL PLAN AND PROFILE

JOB NUMBER	65420975
DATE	AUGUST 2024
DWG	C-503
SHEET	15 of 51

THE USER SHALL BE RESPONSIBLE FOR OBTAINING ALL NECESSARY PERMITS AND APPROVALS FROM ALL APPLICABLE AGENCIES AND AUTHORITIES. THE USER SHALL BE RESPONSIBLE FOR OBTAINING ALL NECESSARY PERMITS AND APPROVALS FROM ALL APPLICABLE AGENCIES AND AUTHORITIES. THE USER SHALL BE RESPONSIBLE FOR OBTAINING ALL NECESSARY PERMITS AND APPROVALS FROM ALL APPLICABLE AGENCIES AND AUTHORITIES.

File Location: D:\Denver_North\Projects\City of Colorado Springs\Sand Creek Pond No. 2\CAD\03\0975-SPRING_RANCH_P&P.dwg Plot Date: 8/26/2024 4:35 PM Last Saved By: TIM.MCMILLEN

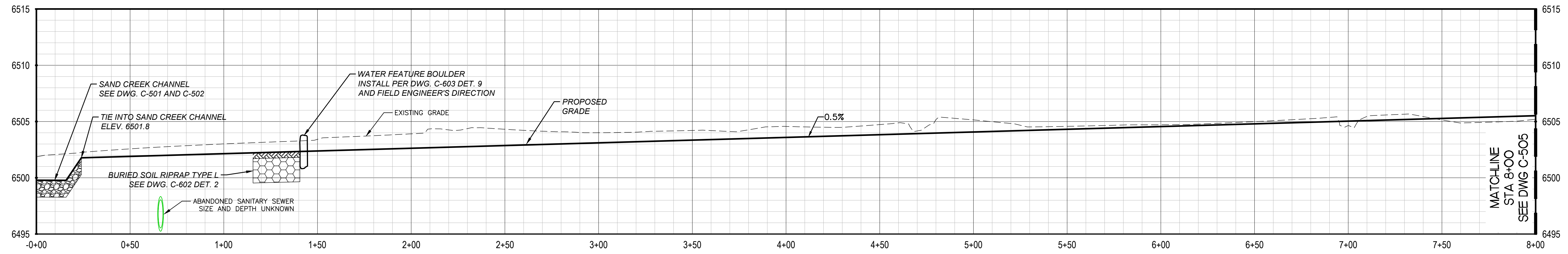
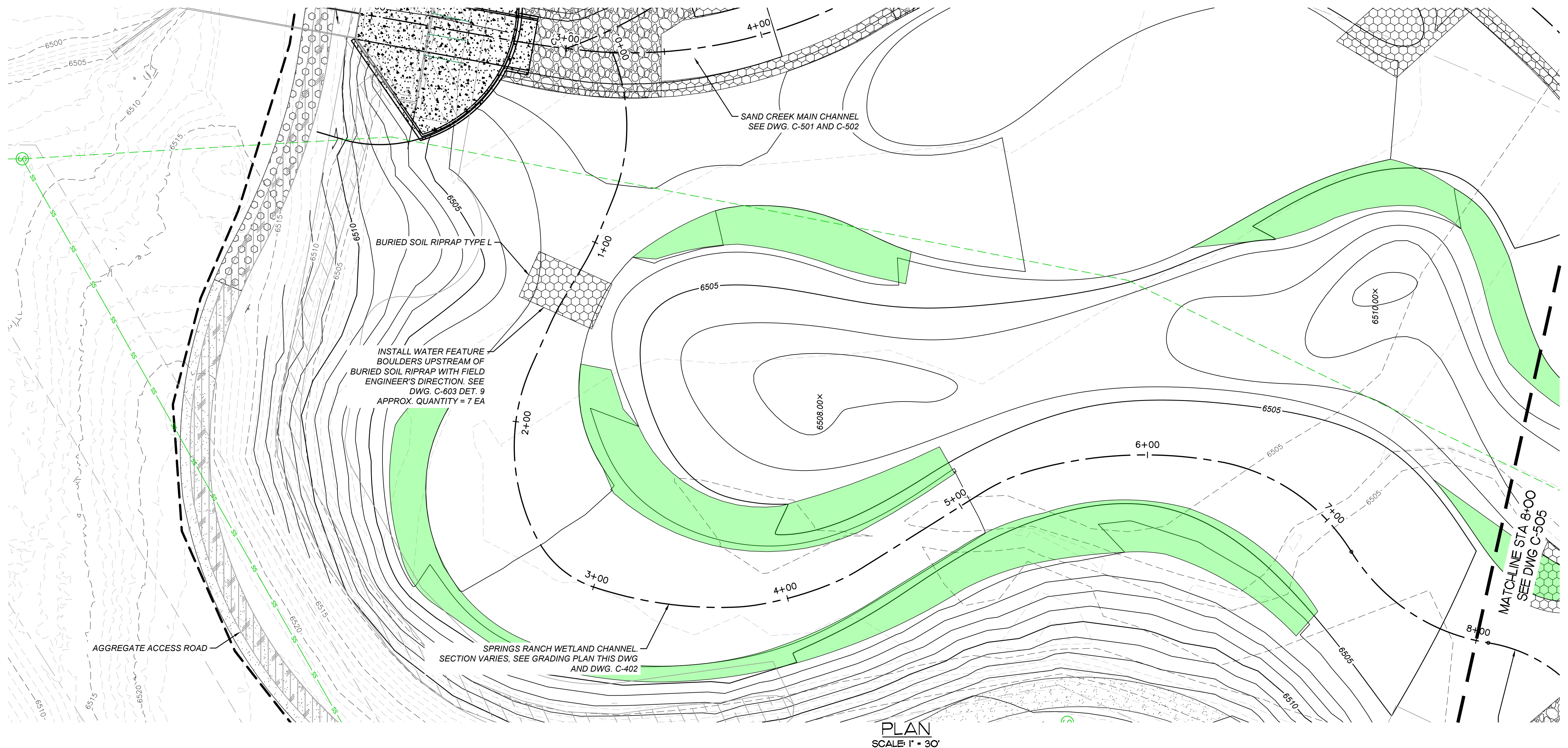

REV	REVISION DESCRIPTION	DATE	CHND	CHKD	APPR

CALL BEFORE YOU DIG

Know what's below.
Call before you dig.

CITY OF COLORADO SPRINGS
30 S. NEVADA AVE., SUITE 401
COLORADO SPRINGS, CO 80903
(719) 385-5980

MERRICK
Engineering | Architecture | Design-Build | Surveying | Planning | Geospatial Solutions
2480 W. 26TH AVE., UNIT B225 - DENVER COLORADO 80211
TEL. 303-751-0741, FAX 303-751-2581
www.merrick.com

PE STAMP

FOR AND ON BEHALF OF MERRICK & COMPANY

TITLE

SAND CREEK DETENTION POND NO. 2

SPRINGS RANCH WETLAND CHANNEL PLAN AND PROFILE

JOB NUMBER: 65420975
DATE: AUGUST 2024
DWG: **C-504**
SHEET 16 of 51

THE CITY OF COLORADO SPRINGS IS PROVIDING THIS INFORMATION AS AN INSTRUMENT OF SERVICE. SERVICES BY MERRICK AND COMPANY, FOR A FEE, ARE NOT GUARANTEED. THIS INFORMATION IS PROVIDED AS IS, WITHOUT WARRANTY OF ANY KIND, INCLUDING MERCHANTABILITY. THE CITY OF COLORADO SPRINGS DOES NOT WARRANT, REPRESENT, OR GUARANTEE THE ACCURACY OF THE INFORMATION. THE CITY OF COLORADO SPRINGS DOES NOT WARRANT, REPRESENT, OR GUARANTEE THE ACCURACY OF THE INFORMATION. THE CITY OF COLORADO SPRINGS DOES NOT WARRANT, REPRESENT, OR GUARANTEE THE ACCURACY OF THE INFORMATION.

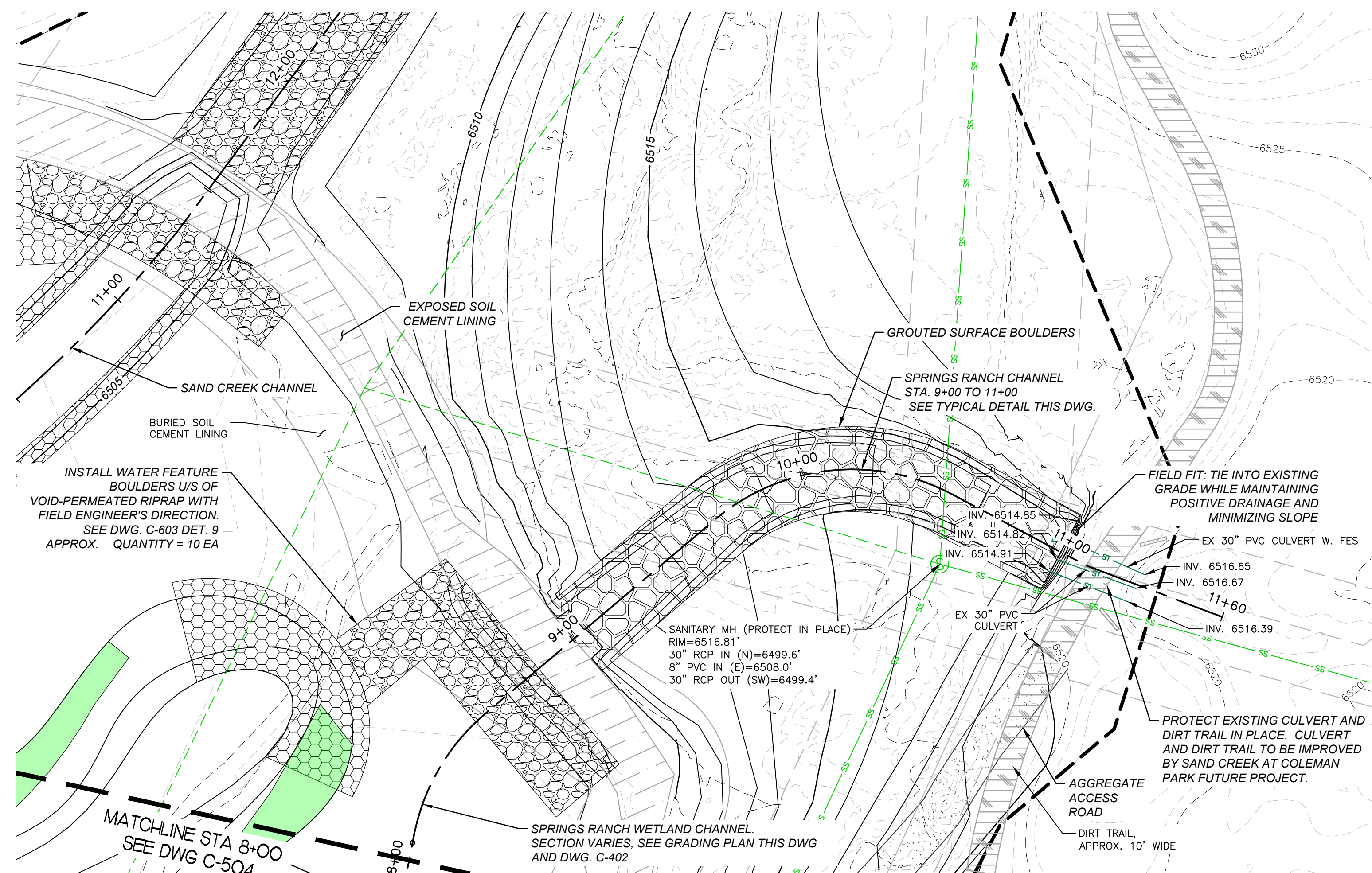

PLAN
SCALE: 1" = 30'

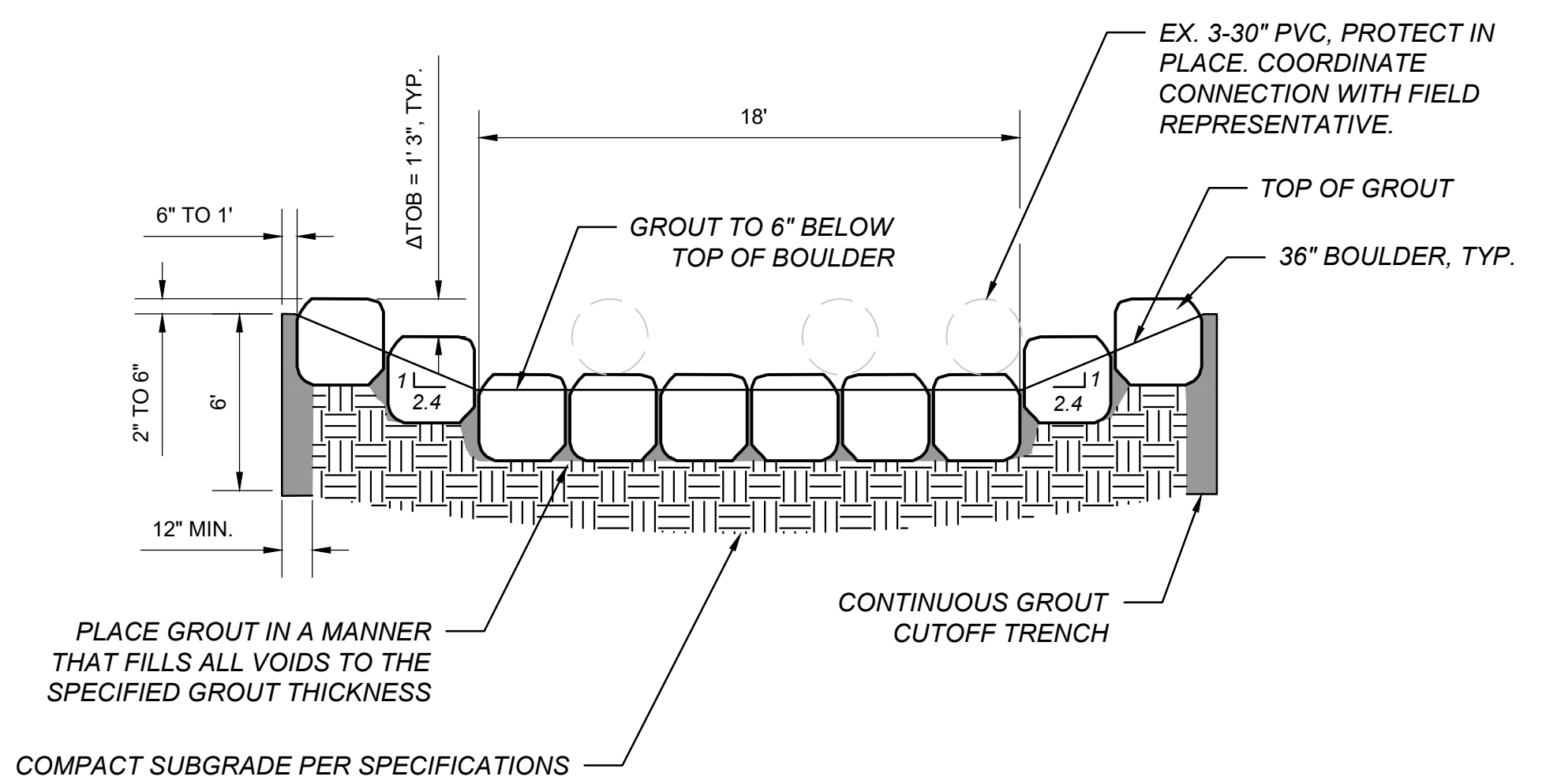
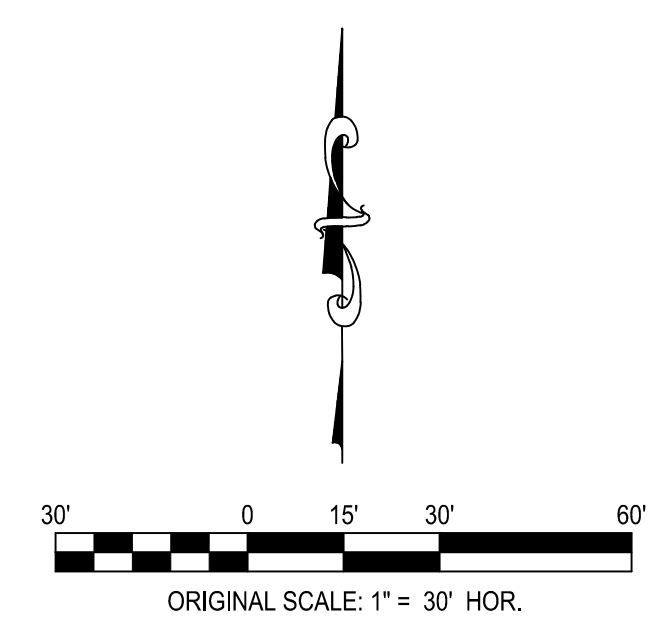

**SPRINGS RANCH CHANNEL
TYPICAL SECTION**
HOR. SCALE: 1" = 5'
VER. SCALE: 1" = 5'

NOTE: PLACE ONE ROW OF BOULDERS THAT TRANSITIONS BETWEEN THE TWO SECTIONS. FOR THE TRANSITION ROW, $\Delta TOB = 8"$, AND GROUT TO 4" BELOW TOP OF BOULDER.

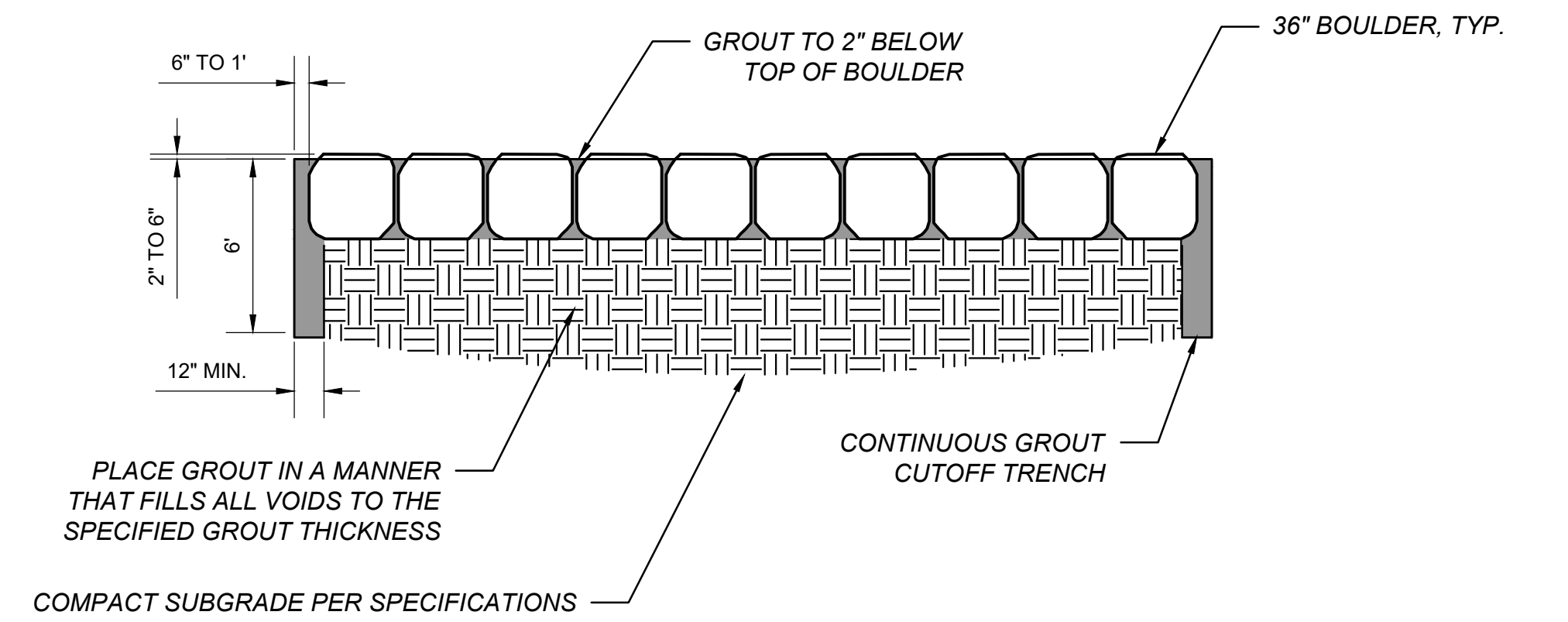

**SPRINGS RANCH CHANNEL
SECTION - DOWNSTREAM MOST ROW OF BOULDERS (STA. 9+00 +/-)**
HOR. SCALE: 1" = 5'
VER. SCALE: 1" = 5'

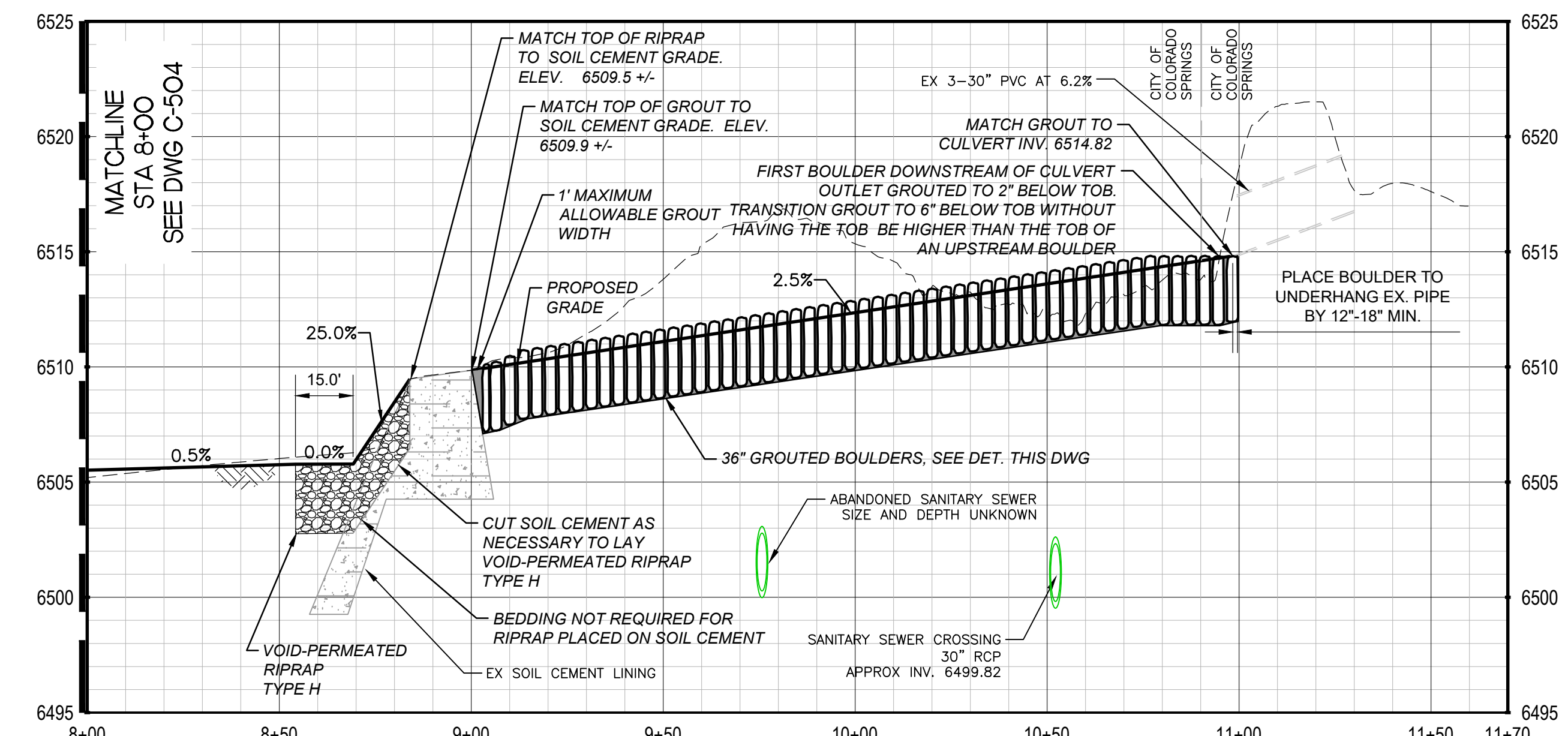

C-505 PROFILE
HOR. SCALE: 1" = 30'
VER. SCALE: 1" = 5'

REV	REVISION DESCRIPTION	DATE	CHND	CHKD	APPR

CALL BEFORE YOU DIG

Know what's below.
Call before you dig.

CITY OF COLORADO SPRINGS
30 S. NEVADA AVE., SUITE 401
COLORADO SPRINGS, CO 80903
(719) 385-5980

MERRICK
Engineering | Architecture | Design-Build | Surveying | Planning | Geospatial Solutions
2480 W. 26TH AVE., UNIT B225 - DENVER COLORADO 80211
TEL. 303-751-0741, FAX 303-751-2581
www.merrick.com

PE STAMP

FOR AND ON BEHALF OF MERRICK & COMPANY

TITLE

SAND CREEK DETENTION POND NO. 2

SPRINGS RANCH CHANNEL PLAN AND PROFILE

JOB NUMBER: 65420975

DATE: AUGUST 2024

DWG: **C-505**

SHEET 17 of 51

THE CITY OF COLORADO SPRINGS IS PROVIDING THIS INFORMATION AS AN INSTRUMENT OF SERVICE. SERVICES BY MERRICK AND COMPANY, INC. ARE THE PROPERTY OF MERRICK AND COMPANY, INC. AND ARE NOT TO BE REPRODUCED OR TRANSMITTED IN ANY FORM OR BY ANY MEANS, ELECTRONIC OR MECHANICAL, INCLUDING PHOTOCOPYING, RECORDING, OR BY ANY INFORMATION STORAGE AND RETRIEVAL SYSTEM, WITHOUT THE WRITTEN PERMISSION OF MERRICK AND COMPANY, INC. THIS INFORMATION IS PROVIDED AS IS AND WITHOUT WARRANTY OF ANY KIND, INCLUDING MERCHANTABILITY AND FITNESS FOR A PARTICULAR PURPOSE. THE USER SHALL BE RESPONSIBLE FOR OBTAINING NECESSARY PERMITS AND APPROVALS FROM ALL APPLICABLE AGENCIES AND AUTHORITIES.

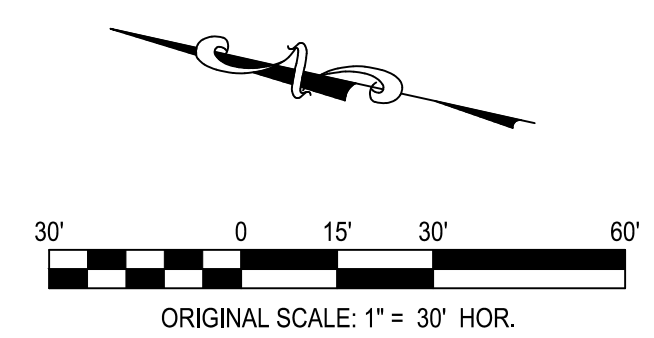
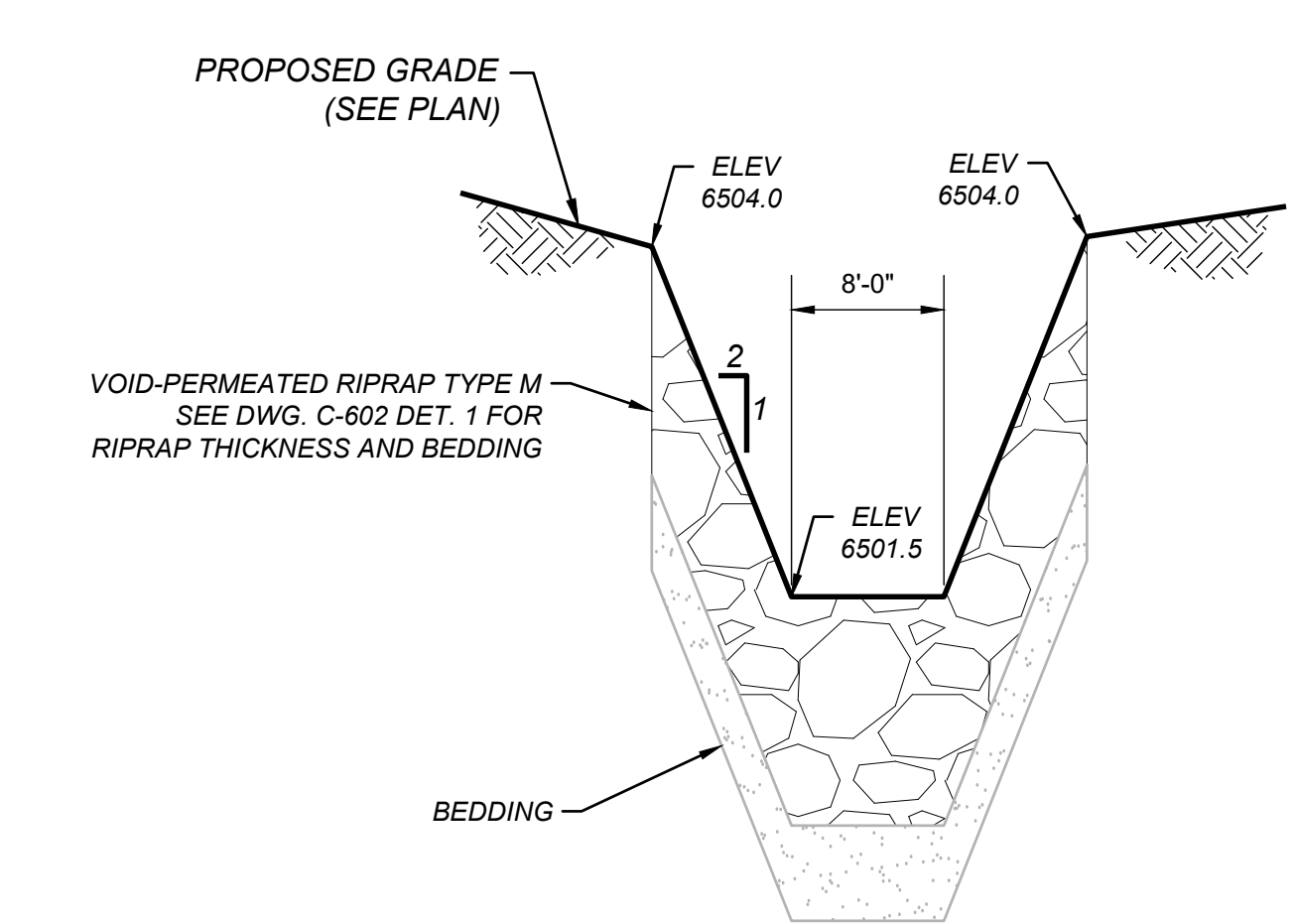
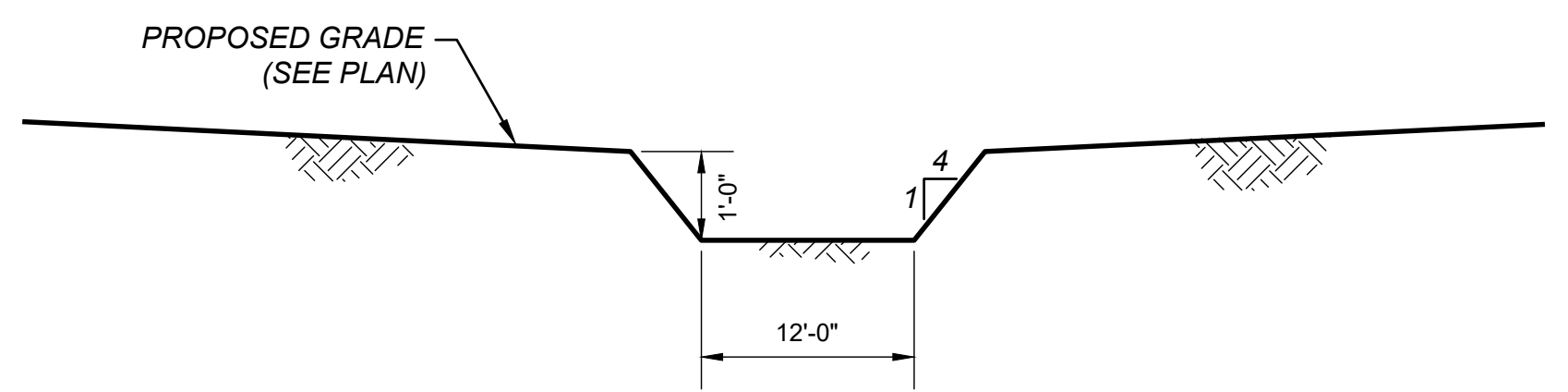
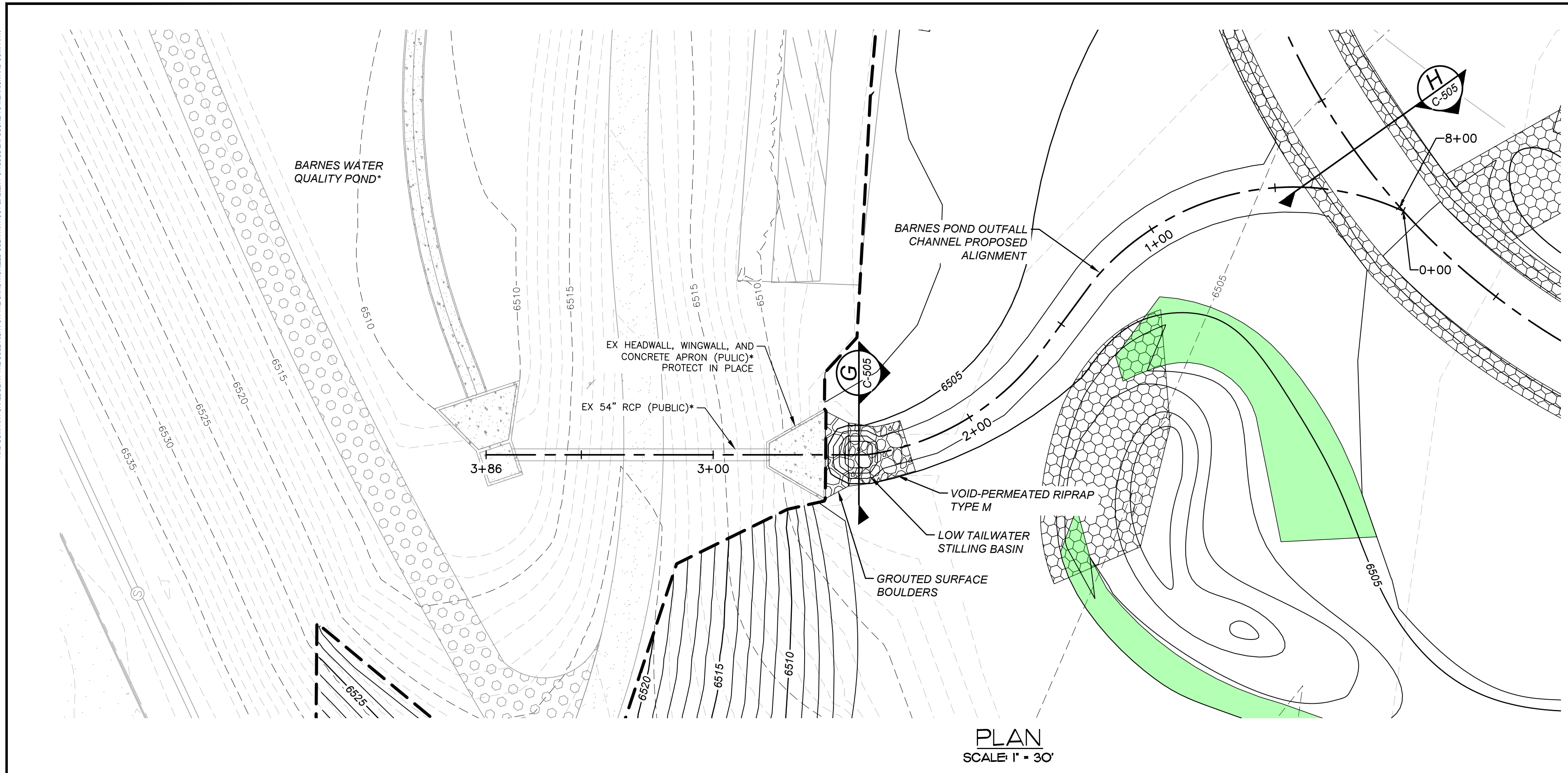

*THIS INFRASTRUCTURE ELEMENT IS PROPOSED AS PART OF THE BARNES WATER QUALITY POND PROJECT, WHICH IS TO BE COMPLETED BEFORE CONSTRUCTION OF SAND CREEK POND NO. 2 RESTORATION BEGINS.

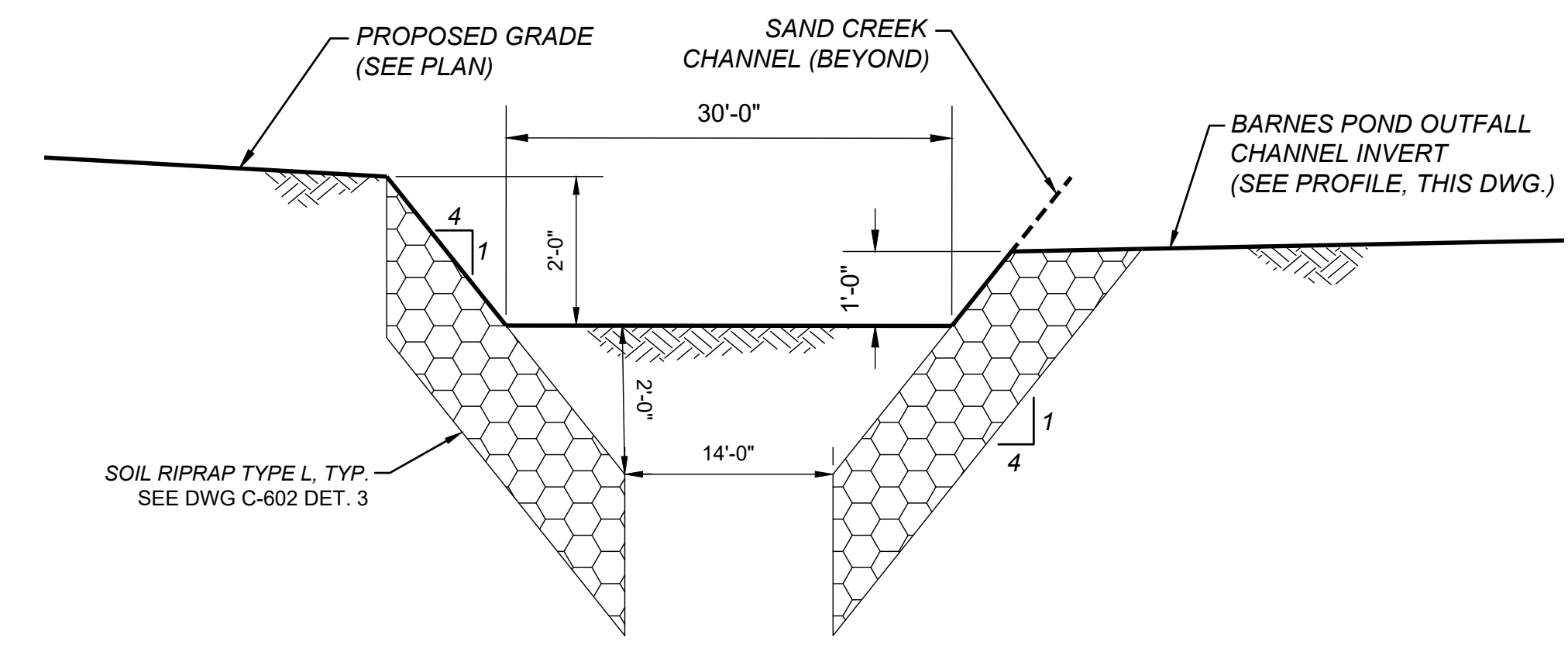
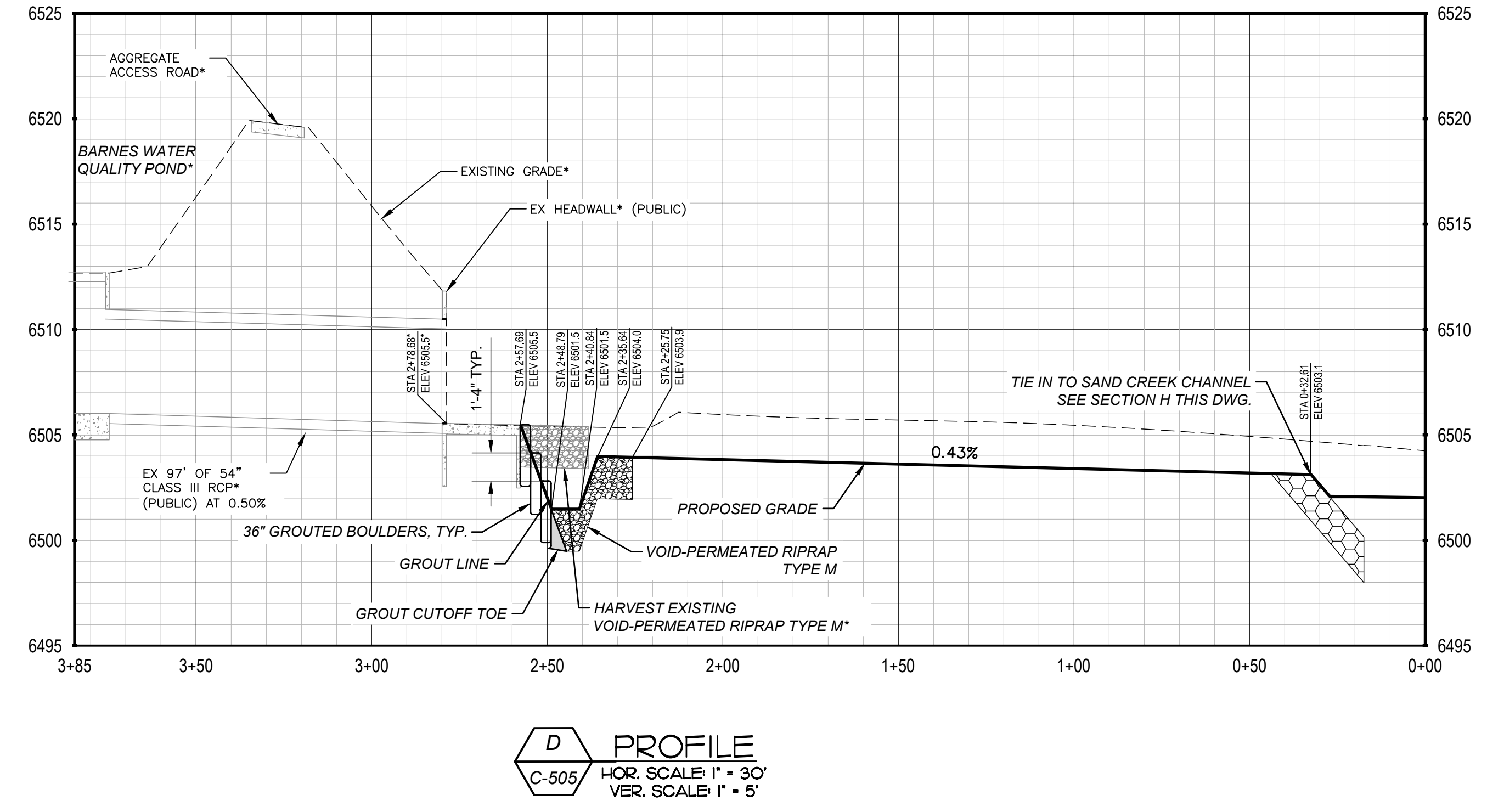

REV	REVISION DESCRIPTION	DATE	CHND	CHKD	APPR

CALL BEFORE YOU DIG

Know what's below.
Call before you dig.

CITY OF COLORADO SPRINGS
30 S. NEVADA AVE., SUITE 401
COLORADO SPRINGS, CO 80903
(719) 385-5980

MERRICK
Engineering | Architecture | Design-Build | Surveying | Planning | Geospatial Solutions
2480 W. 26TH AVE., UNIT B225 - DENVER COLORADO 80211
TEL. 303-751-0741, FAX 303-751-2581
www.merrick.com

PE STAMP

FOR AND ON BEHALF OF MERRICK & COMPANY

TITLE

SAND CREEK DETENTION POND NO. 2

BARNES WQ POND OUTFALL PIPE AND CHANNEL PLAN AND PROFILE

JOB NUMBER: 65420975
DATE: AUGUST 2024
DWG: C-506
SHEET 18 of 51

THE NEW ORANGE COUNTY ENGINEERING DIVISION HAS REVIEWED THIS INSTRUMENT OF SERVICE PROVIDED BY MERRICK AND COMPANY, INC. FOR A BARNES WATER QUALITY POND PROJECT. IT IS NOT INTENDED OR REPRESENTED TO BE A FINAL DESIGN OR PART OF THE INSTRUMENT OF SERVICE. THE PROJECT OR ANY OTHER PROJECT, REUSE OR MODIFICATION OF ANY INFORMATION NOT A FINISHED INSTRUMENT, WITHOUT THE PRIOR EXPRESS WRITTEN CONSENT OF MERRICK AND COMPANY, SHALL BE AT THE USER'S RISK. THE USER SHALL BE RESPONSIBLE FOR OBTAINING ALL NECESSARY PERMITS AND APPROVALS.

File Location: D:\Denver_North\Projects\City of Colorado Springs\Sand Creek Pond No. 2\CAD\C507\ROAD-PROFILES.dwg Plot Date: 8/26/2024 4:38 PM Last Saved By: TIMMCMULLEN

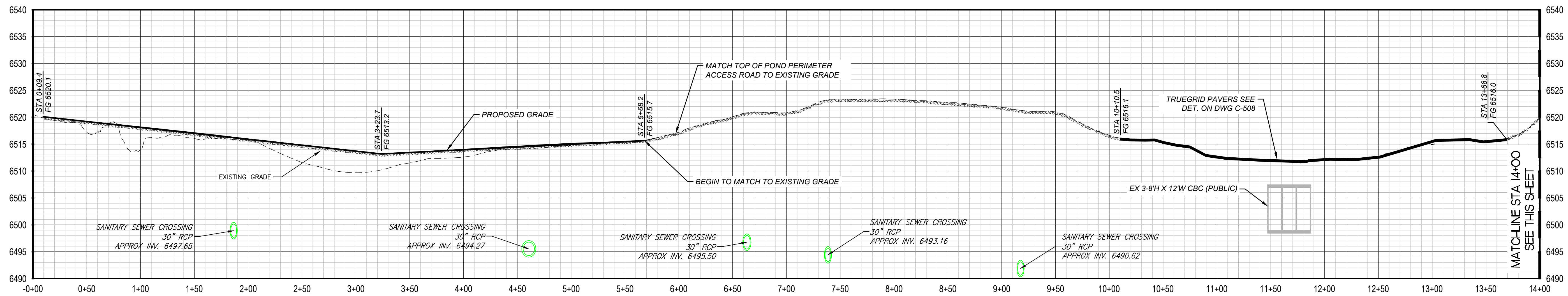

E
C-506
POND PERIMETER ACCESS ROAD PROFILE
 HOR. SCALE: 1" = 50'
 VER. SCALE: 1" = 10'

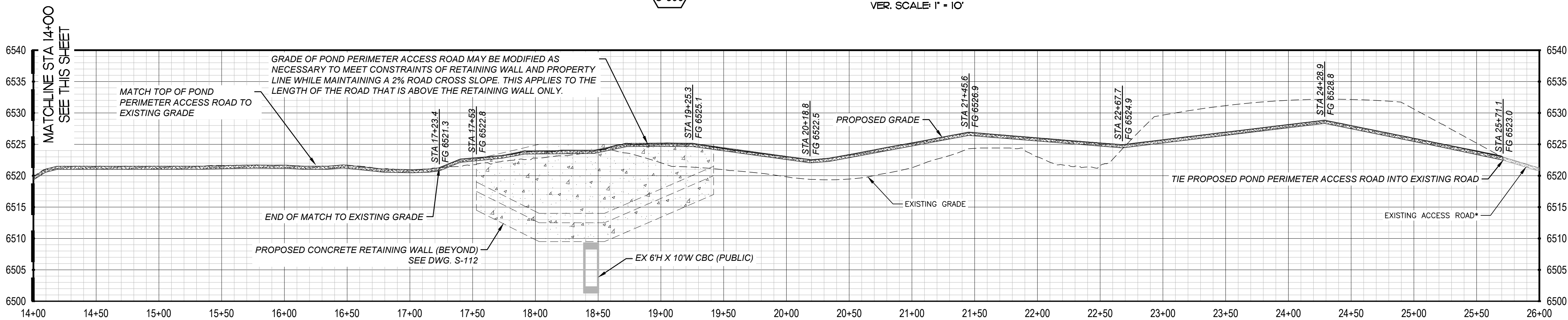

E
C-506
POND PERIMETER ACCESS ROAD PROFILE
 HOR. SCALE: 1" = 50'
 VER. SCALE: 1" = 10'

*THIS INFRASTRUCTURE ELEMENT IS PROPOSED AS PART OF THE BARNES WATER QUALITY POND PROJECT, WHICH IS TO BE COMPLETED BEFORE CONSTRUCTION OF SAND CREEK POND NO. 2 RESTORATION BEGINS.

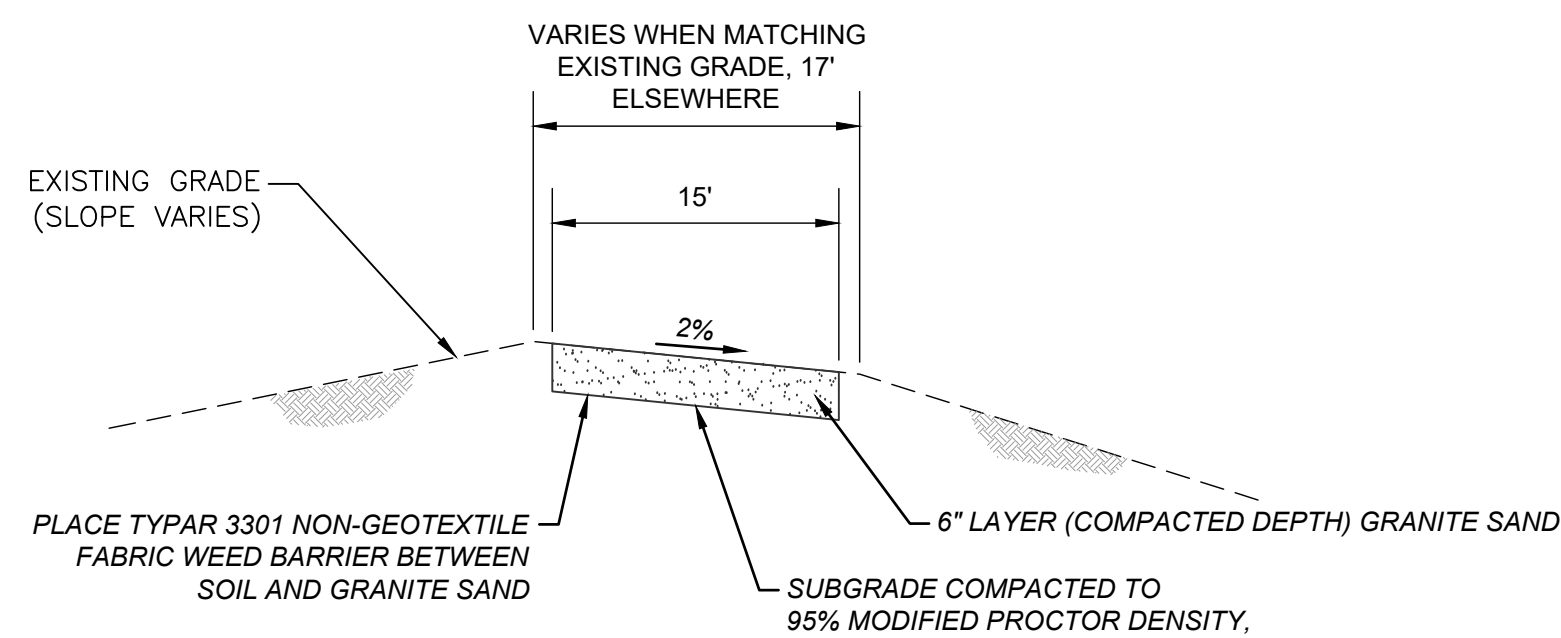

POND PERIMETER ACCESS ROAD SECTION

NTS

REV	REVISION DESCRIPTION	DATE	CHND	CHKD	APPR



CITY OF COLORADO SPRINGS
30 S. NEVADA AVE., SUITE 401
COLORADO SPRINGS, CO 80903
(719) 385-5980



SAND CREEK DETENTION POND NO. 2

POND PERIMETER ACCESS ROAD PROFILE

JOB NUMBER	65420975
DATE	AUGUST 2024
DWG	C-507
SHEET	19 of 51

THE USE OF THIS DRAWING IS LIMITED TO THE PROJECT AND SITE SPECIFICALLY IDENTIFIED HEREON. ANY OTHER USE, REUSE OR MODIFICATION OF ANY INFORMATION NOT A FINISHED INSTRUMENT WITHOUT THE PRIOR EXPRESS WRITTEN CONSENT OF MERRICK & COMPANY SHALL BE AT THE USER'S RISK. THE USER SHALL BE RESPONSIBLE FOR OBTAINING ALL NECESSARY PERMITS AND APPROVALS FROM ALL APPLICABLE AGENCIES.

File Location: D:\Denver_North\Projects\City of Colorado Springs\Sand Creek Pond No. 2\CAD\09\0975-ROAD-PROFILES.dwg Plot Date: 8/26/2024 4:38 PM Last Saved By: TIMMCMULLEN

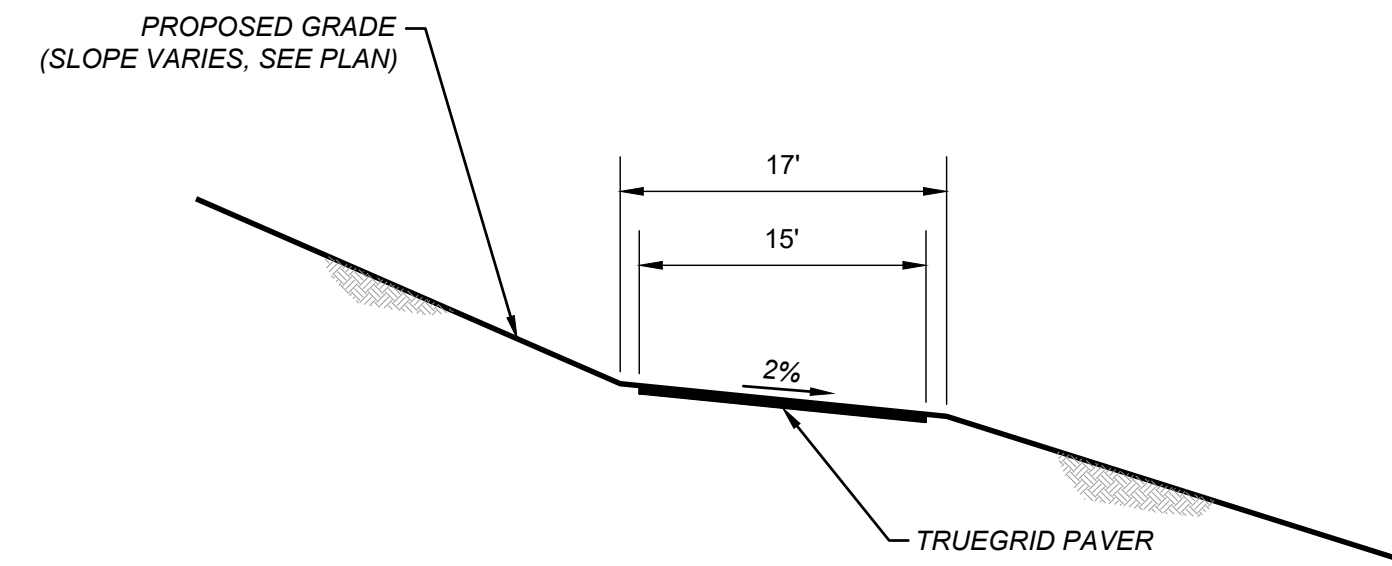
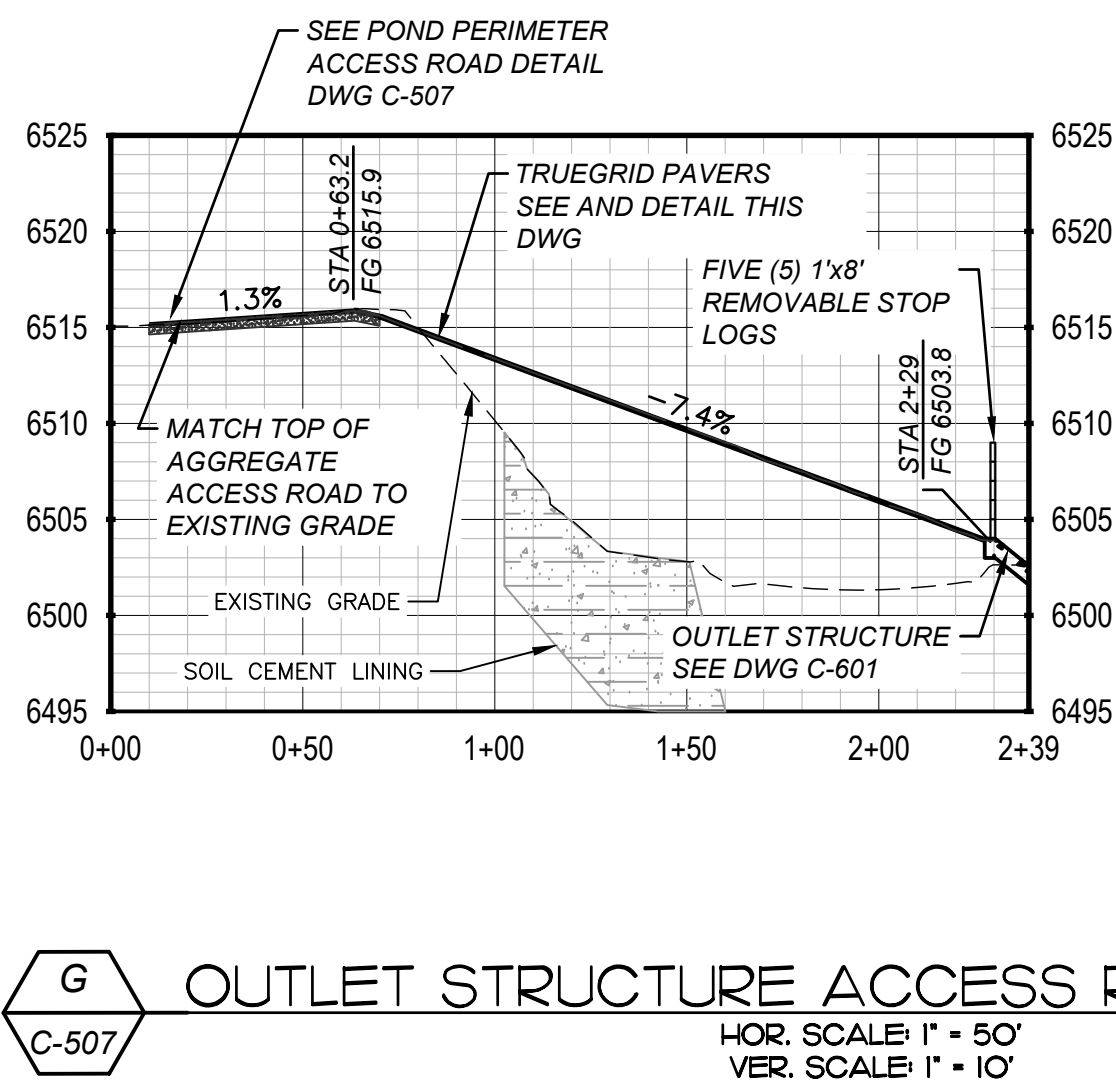
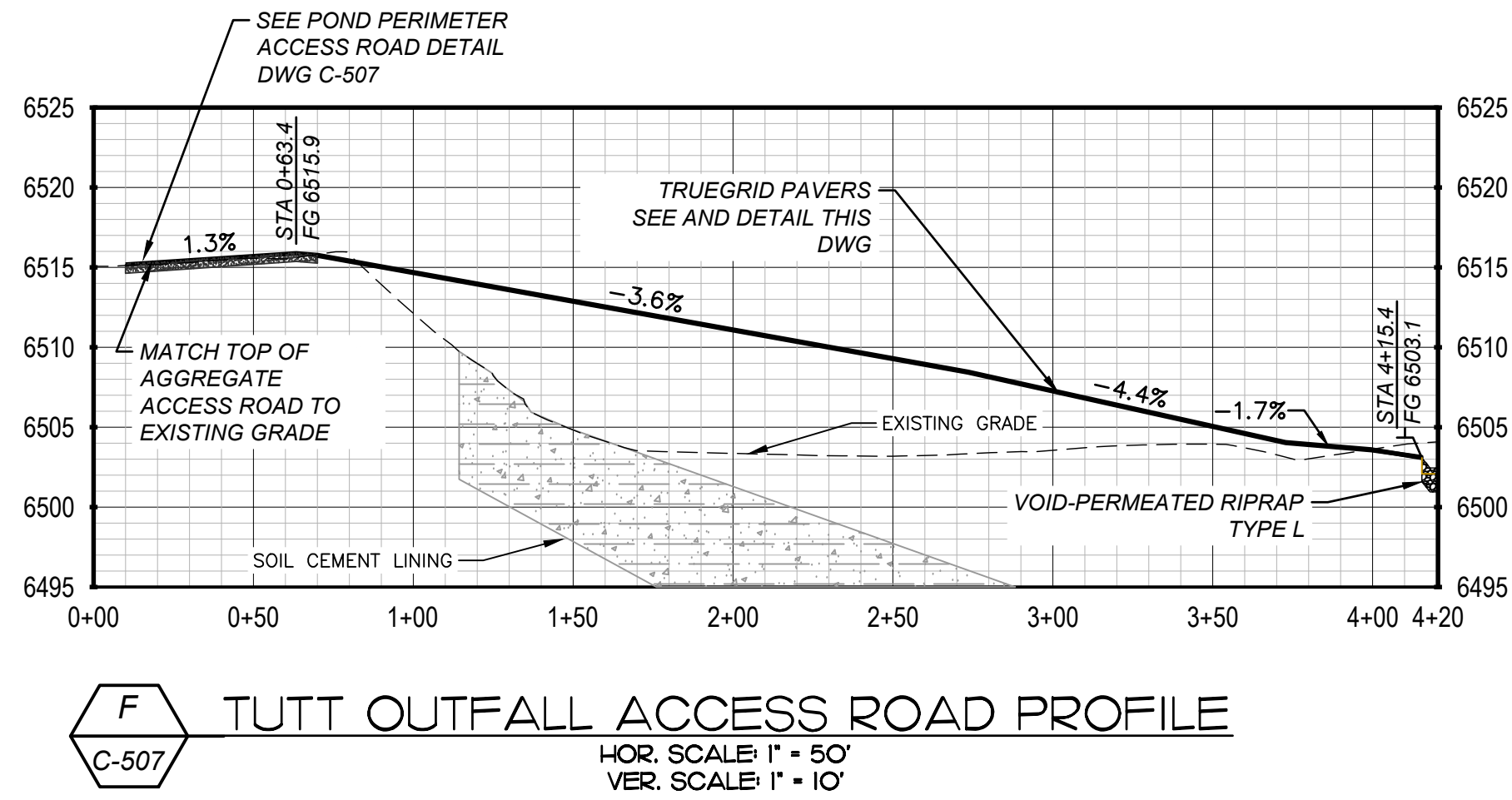

TRUEGRID PAVERS ACCESS ROAD
 NTS

REV	REVISION DESCRIPTION	DATE	CHND	CHKD	APPR

CALL BEFORE YOU DIG

Know what's below.
 Call before you dig.

CITY OF COLORADO SPRINGS
 30 S. NEVADA AVE., SUITE 401
 COLORADO SPRINGS, CO 80903
 (719) 385-5980

MERRICK
 Engineering | Architecture | Design-Build | Surveying | Planning | Geospatial Solutions
 2480 W. 26TH AVE., UNIT B225 - DENVER COLORADO 80211
 TEL. 303-751-0741, FAX 303-751-2581
 www.merrick.com

PE STAMP

FOR AND ON BEHALF OF MERRICK & COMPANY

TITLE

SAND CREEK DETENTION POND NO. 2

OUTLET STRUCTURE AND TUTT OUTFALL ACCESS ROAD PROFILES AND DETAILS

JOB NUMBER: 65420975
 DATE: AUGUST 2024
 DWG: **C-508**
 SHEET: 20 of 51

THE USE OF THESE PLANS IS LIMITED TO THE PROJECT AND SITE SPECIFICALLY IDENTIFIED HEREIN. ANY OTHER USE, REUSE OR MODIFICATION OF ANY INFORMATION NOT A PART OF THIS PROJECT IS PROHIBITED. THE USER SHALL BE RESPONSIBLE FOR OBTAINING ALL NECESSARY PERMITS AND APPROVALS FROM THE APPROPRIATE AGENCIES. THE USER SHALL BE RESPONSIBLE FOR OBTAINING ALL NECESSARY PERMITS AND APPROVALS FROM THE APPROPRIATE AGENCIES.

File Location: D:\Denver_North\Projects\City of Colorado Springs\Sand Creek Pond No. 2\CAD\CCS\0975-DETAIL-POND-OUTFALL.dwg Plot Date: 8/26/2024 4:38 PM Last Saved By: TIM MULLIN

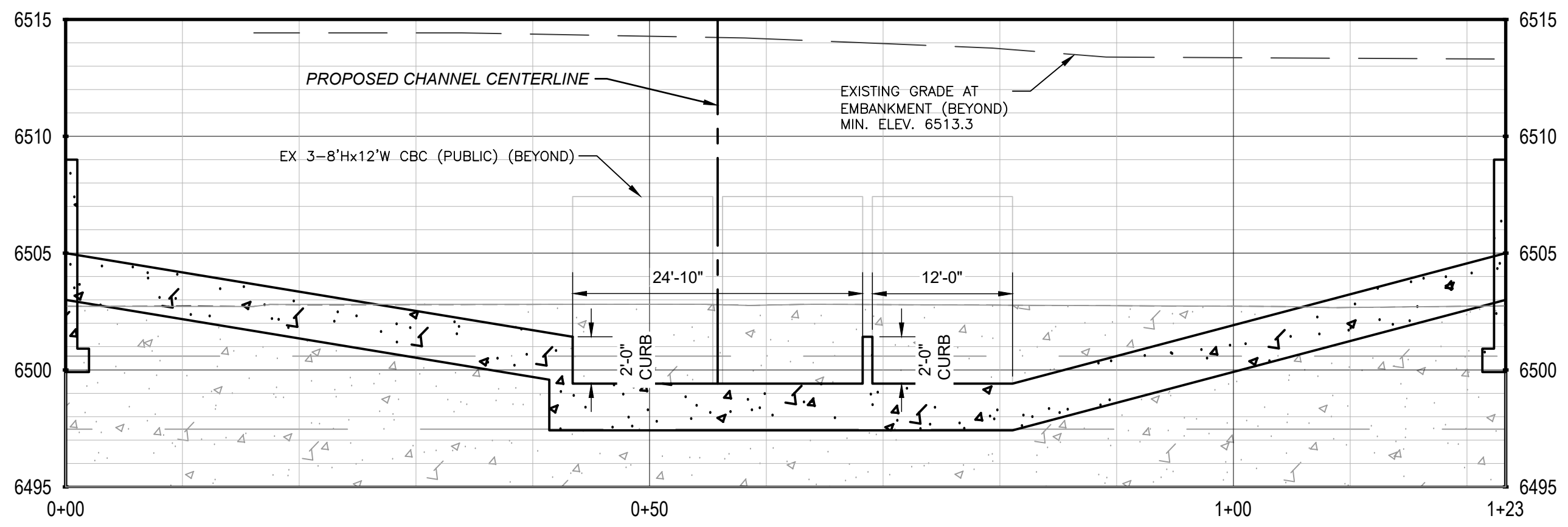
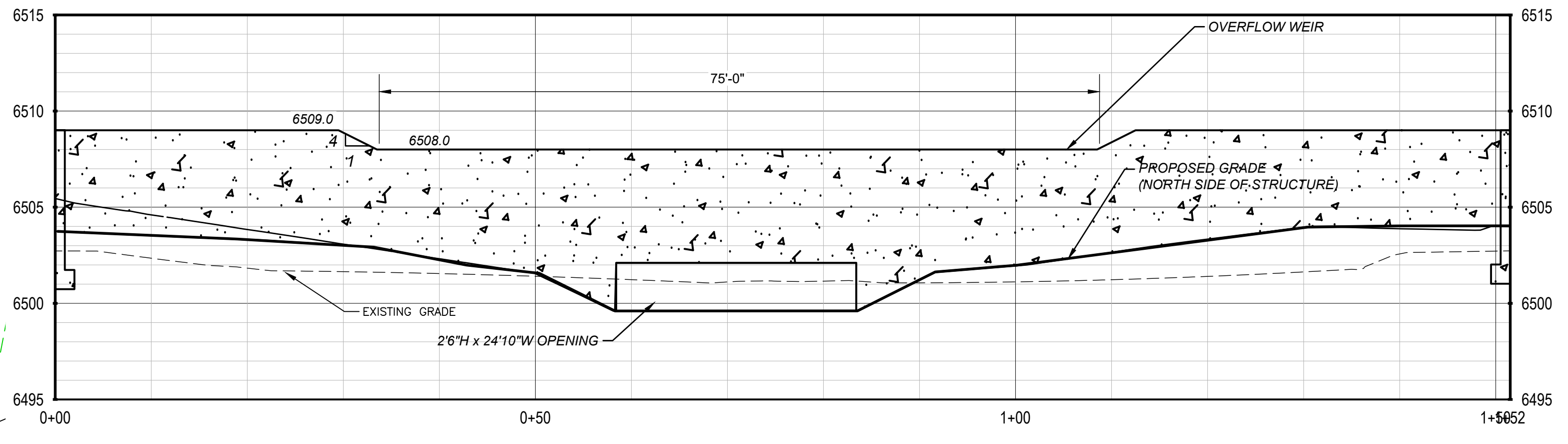
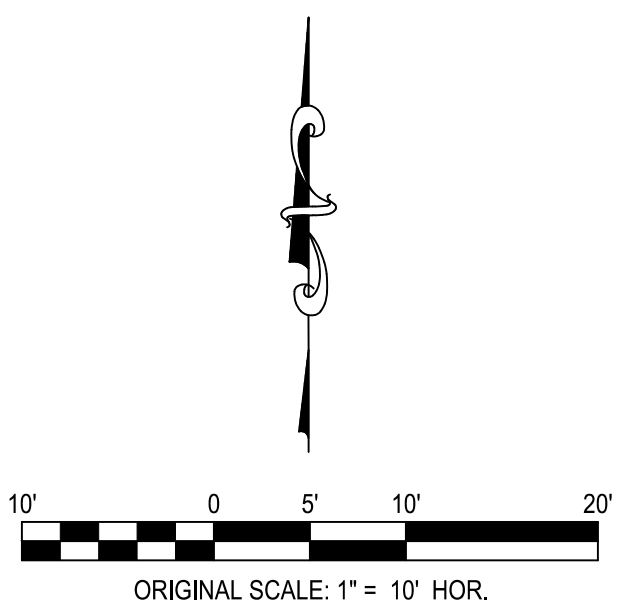
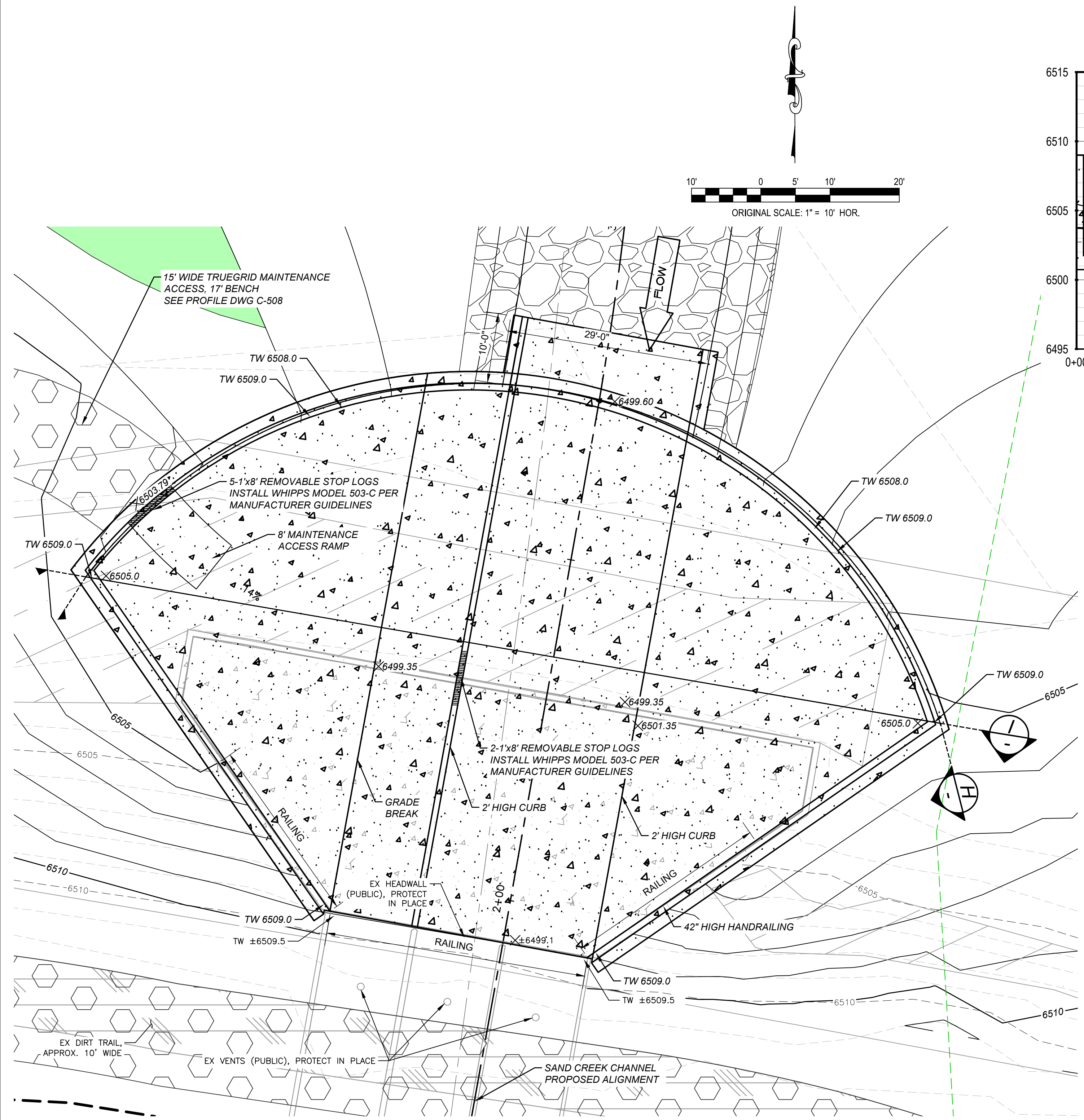

SEE DWGS S-100 THROUGH S-117 FOR STRUCTURAL DESIGN.
 DWGS S-100 THROUGH S-117 TO TAKE PRECEDENCE OVER DWG C-601 IF CONFLICTING.

REV	REVISION DESCRIPTION	DATE	CHND	CHKD	APPR

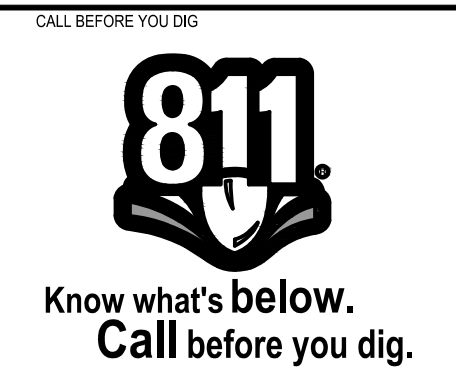

CITY OF COLORADO SPRINGS
 30 S. NEVADA AVE., SUITE 401
 COLORADO SPRINGS, CO 80903
 (719) 385-5980

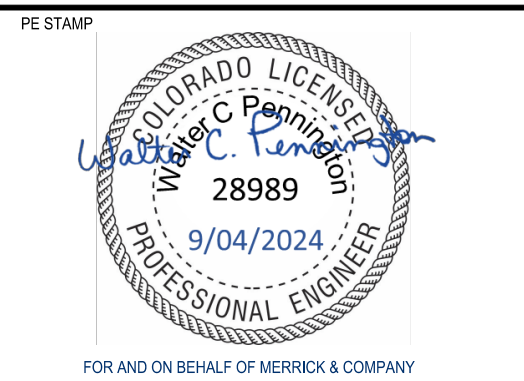

TITLE
SAND CREEK DETENTION POND NO. 2
POND OUTLET STRUCTURE
DETAIL

JOB NUMBER	65420975
DATE	AUGUST 2024
DWG	C-601
SHEET	21 of 51

THE USE OF ANY OTHER ENGINEERING MATERIAL OR INSTRUMENTATION IS AN INSTRUMENT OF SERVICE PROVIDED BY MERRICK AND COMPANY, INC. IN CONNECTION WITH THIS PROJECT. IT IS NOT INTENDED OR REPRESENTED TO BE SUITABLE FOR REUSE IN WHOLE OR IN PART OR FOR EXTENSION OF THE PROJECT OR ON ANY OTHER PROJECT. REUSE OR MODIFICATION OF ANY INSTRUMENTATION WITHOUT THE WRITTEN PERMISSION OF MERRICK AND COMPANY SHALL BE AT THE USER'S RISK. THE USER SHALL BE RESPONSIBLE FOR OBTAINING NECESSARY PERMISSIONS FOR REUSE AND MODIFICATION.

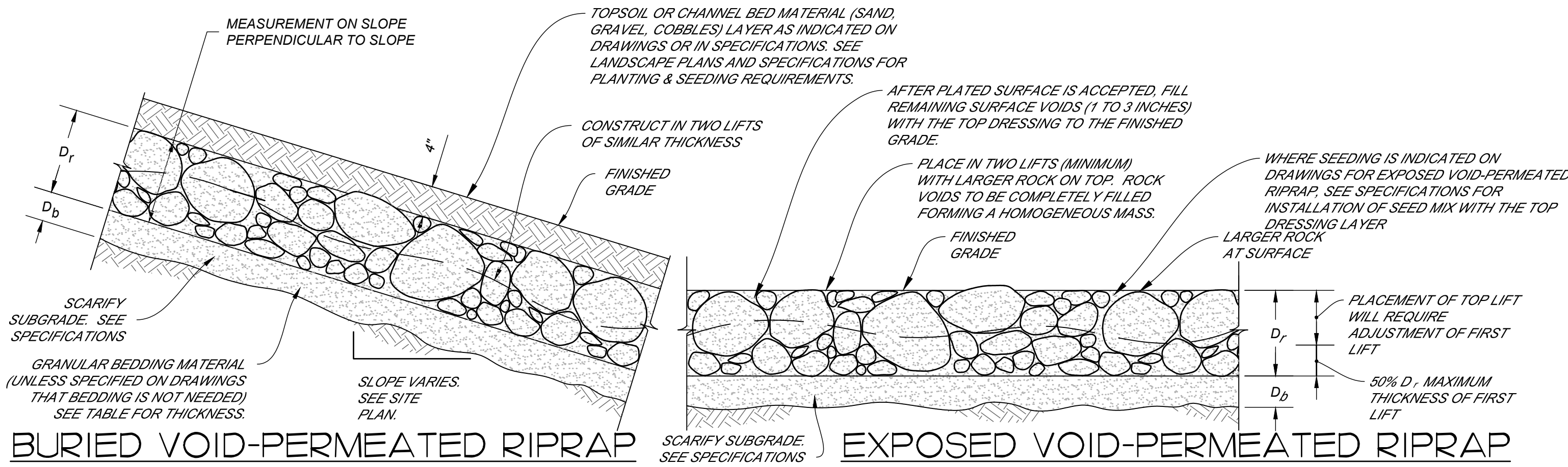

USED THIS PROJECT	RIPRAP TYPE	D ₅₀	D _r	D _b / SCARIFY DEPTH
	VL	6	12	8
X	L	9	18	8
X	M	12	24	10
X	H	18	36	12
	VH	24	48	12

- NOTES FOR VOID-PERMEATED RIPRAP:**
- EXPOSED AND BURIED VOID-PERMEATED RIPRAP DETAILS ARE APPLICABLE TO FLAT OR SLOPED AREAS. REFER TO SITE PLAN FOR ACTUAL LOCATION AND LIMITS OF EACH TYPE.
 - REFER TO SPECIFICATIONS FOR MATERIALS, MIXING, AND PLACEMENT REQUIREMENTS FOR VOID-PERMEATED RIPRAP.
 - GENERAL PLACEMENT TECHNIQUES SHOULD RESULT IN LARGER ROCK AT THE SURFACE WITH ROCK SECURELY INTERLOCKED AT THE DESIGN THICKNESS AND GRADE. COMPACTION AND LEVELING SHOULD RESULT IN MINIMAL VOIDS AND PROJECTIONS ABOVE GRADE. TYPICAL FOR BOTH BURIED AND EXPOSED VOID-PERMEATED RIPRAP.
 - FINAL VOID-PERMEATED RIPRAP TO BE COMPACTED BY FULL LOADING OF EXCAVATOR BUCKET OR VIBRATORY PLATE COMPACTOR ATTACHED TO EXCAVATOR BOOM/STICK AS APPROVED BY ENGINEER. ANY SOFT, YIELDING OR POCKETS OF SMALL ROCK WILL BE REWORKED.
 - SUBGRADE SHALL BE SCARIFIED PRIOR TO PLACEMENT OF RIPRAP. SEE SPECIFICATIONS.
 - COORDINATE ROCK PLACEMENT TO PROVIDE TREE OR SHRUB PLANTING PITS WHEN INDICATED ON PLANTING PLANS.

D_r = DEPTH OF RIPRAP LAYER. (UNLESS NOTED OTHERWISE ON PLANS, DETAILS, AND SECTIONS)

D_b = MINIMUM BEDDING THICKNESS. SEE SPECIFICATIONS

TYPICAL VOID-PERMEATED RIPRAP PLACEMENT

NTS

1
C-602

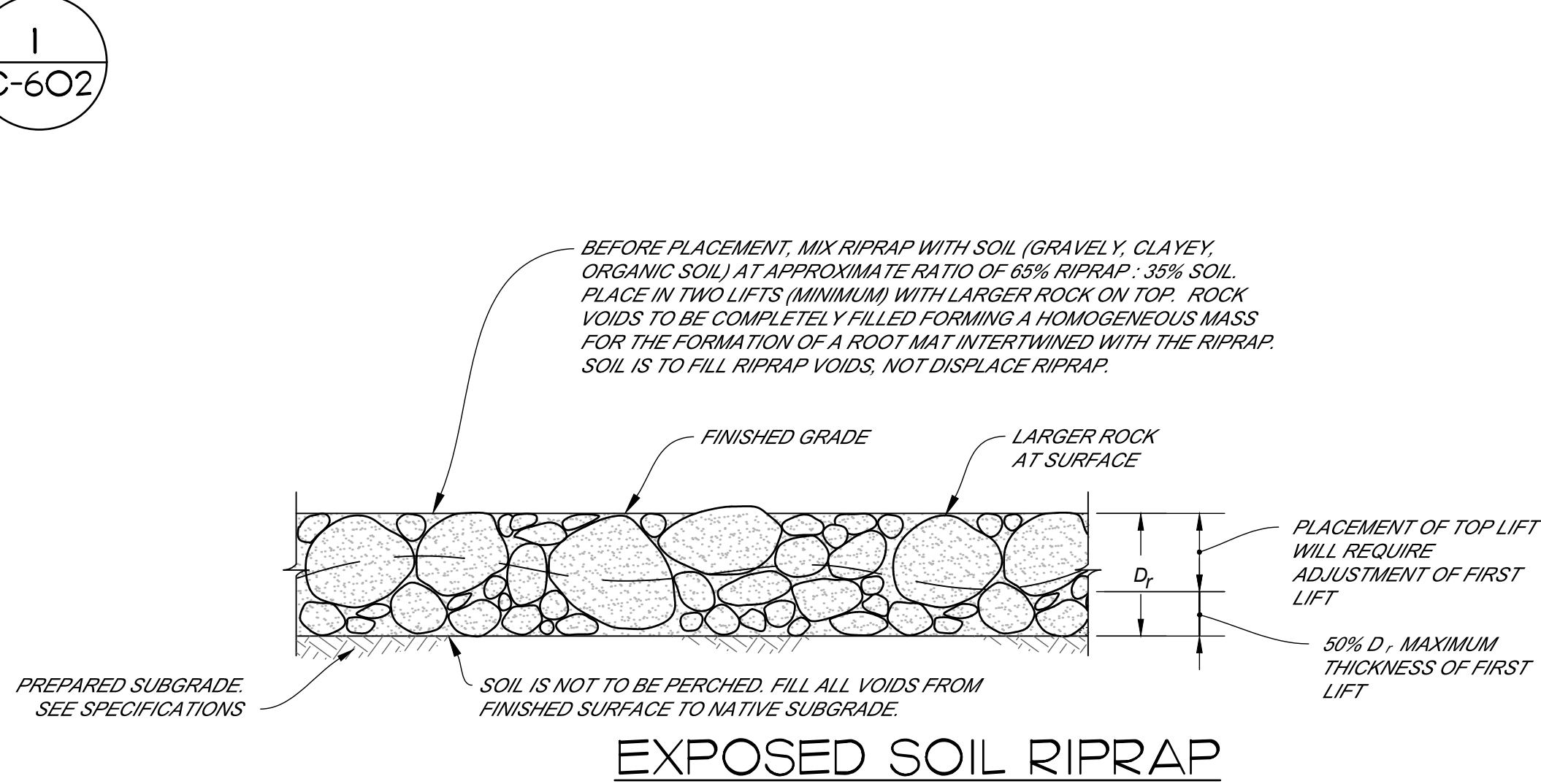
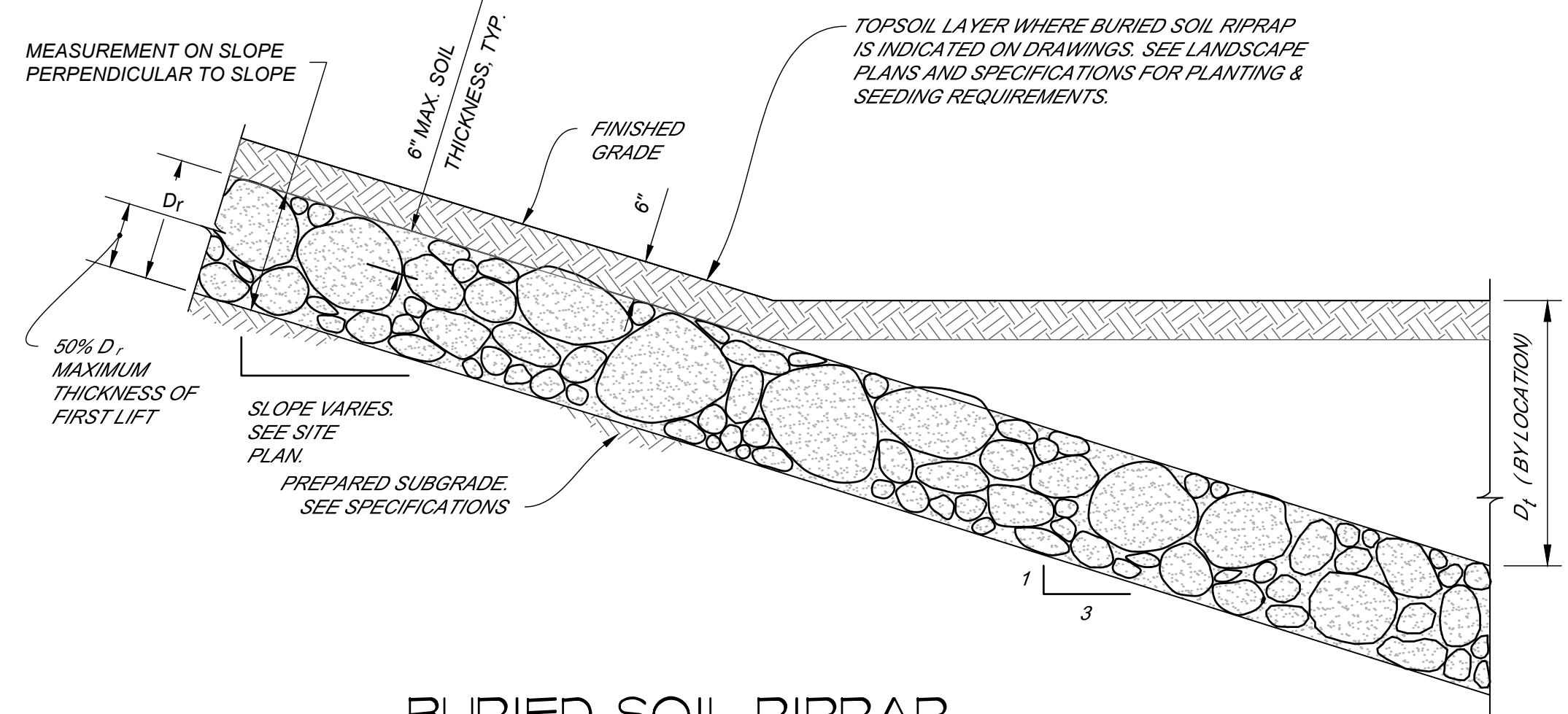

LOCATION	D _t
ISLAND OR D/S OF WATER FEATURE BOULDERS	24
BARNES WATER QUALITY POND EMERGENCY SPILLWAY	36

USED THIS PROJECT	RIPRAP TYPE	D ₅₀	D _r
	VL	6	20
X	L	9	26
	M	12	32
	H	18	44

- NOTES FOR SOIL RIPRAP:**
- EXPOSED AND BURIED SOIL RIPRAP DETAILS ARE APPLICABLE TO FLAT OR SLOPED AREAS. REFER TO SITE PLAN FOR ACTUAL LOCATION AND LIMITS OF EACH TYPE.
 - REFER TO SPECIFICATIONS FOR MATERIALS, MIXING, AND PLACEMENT REQUIREMENTS FOR SOIL RIPRAP.
 - GENERAL PLACEMENT TECHNIQUES SHOULD RESULT IN LARGER ROCK AT THE SURFACE WITH ROCK SECURELY INTERLOCKED AT THE DESIGN THICKNESS AND GRADE. COMPACTION AND LEVELING SHOULD RESULT IN MINIMAL VOIDS AND PROJECTIONS ABOVE GRADE. TYPICAL FOR BOTH BURIED AND EXPOSED SOIL RIPRAP.
 - FINAL SOIL RIPRAP TO BE COMPACTED BY FULL LOADING OF EXCAVATOR BUCKET OR VIBRATORY PLATE COMPACTOR ATTACHED TO EXCAVATOR BOOM/STICK AS APPROVED BY ENGINEER. ANY SOFT, YIELDING OR POCKETS OF SMALL ROCK WILL BE REWORKED.
 - COORDINATE ROCK PLACEMENT TO PROVIDE TREE OR SHRUB PLANTING WELLS WHEN INDICATED ON PLANTING PLANS.

D_r = DEPTH OF RIPRAP LAYER. (UNLESS NOTED OTHERWISE ON PLANS, DETAILS, AND SECTIONS)

TYPICAL SOIL RIPRAP PLACEMENT

NTS

2
C-602

File Location: Q:\Denver - North\Projects\City of Colorado Springs\Sand Creek Pond No. 2\CAD\CDS\0975-DETAIL-RIPRAP.dwg Plot Date: 8/26/2024 4:39 PM Last Saved By: TIM.MCMULLEN

REV	REVISION DESCRIPTION	DATE	CHND	CHKD	APPR

CALL BEFORE YOU DIG

Know what's below.
Call before you dig.

CITY OF COLORADO SPRINGS
 30 S. NEVADA AVE., SUITE 401
 COLORADO SPRINGS, CO 80903
 (719) 385-5980

Engineering | Architecture | Design-Build | Surveying | Planning | Geospatial Solutions

2480 W. 26TH AVE., UNIT B225 - DENVER COLORADO 80211
 TEL. 303-751-0741, FAX 303-751-2581
 www.merrick.com

PE STAMP

FOR AND ON BEHALF OF MERRICK & COMPANY

TITLE

SAND CREEK DETENTION POND NO. 2

RIPRAP DETAILS

JOB NUMBER: 65420975

DATE: AUGUST 2024

DWG: C-602

SHEET 22 of 51

THE NEW ORANGE COUNTY ENGINEERING DIVISION HAS REVIEWED THIS INSTRUMENT OF SERVICE PROVIDED BY MERRICK AND COMPANY FOR A RESURFACING PROJECT. REUSE OR MODIFICATION OF ANY INFORMATION NOT A FINISHED INSTRUMENT WITHOUT THE PRIOR EXPRESS WRITTEN CONSENT OF MERRICK AND COMPANY SHALL BE AT THE USER'S RISK FOR THE USER'S USE WITHOUT LIABILITY TO MERRICK AND COMPANY.

File Location: D:\Denver_North\Projects\City of Colorado Springs\Sand Creek Pond No. 2\CAD\CCS\0975-SITE_PLAN.dwg Plt Date: 8/26/2024 4:40 PM Last Saved By: TIM.MCMULLEN

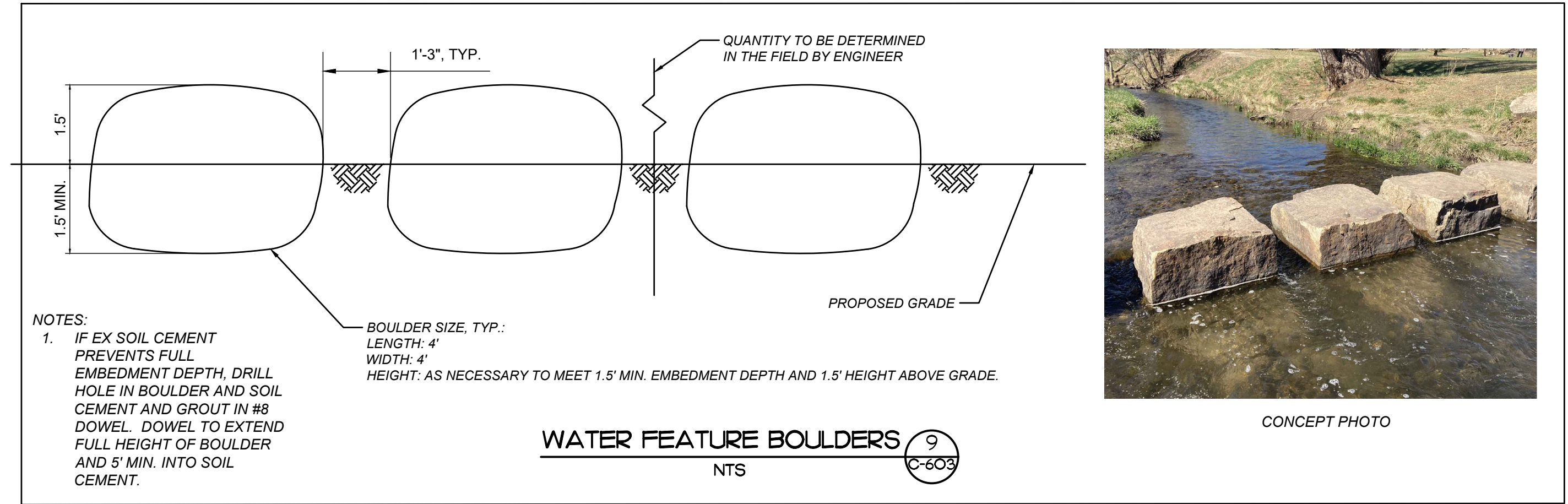
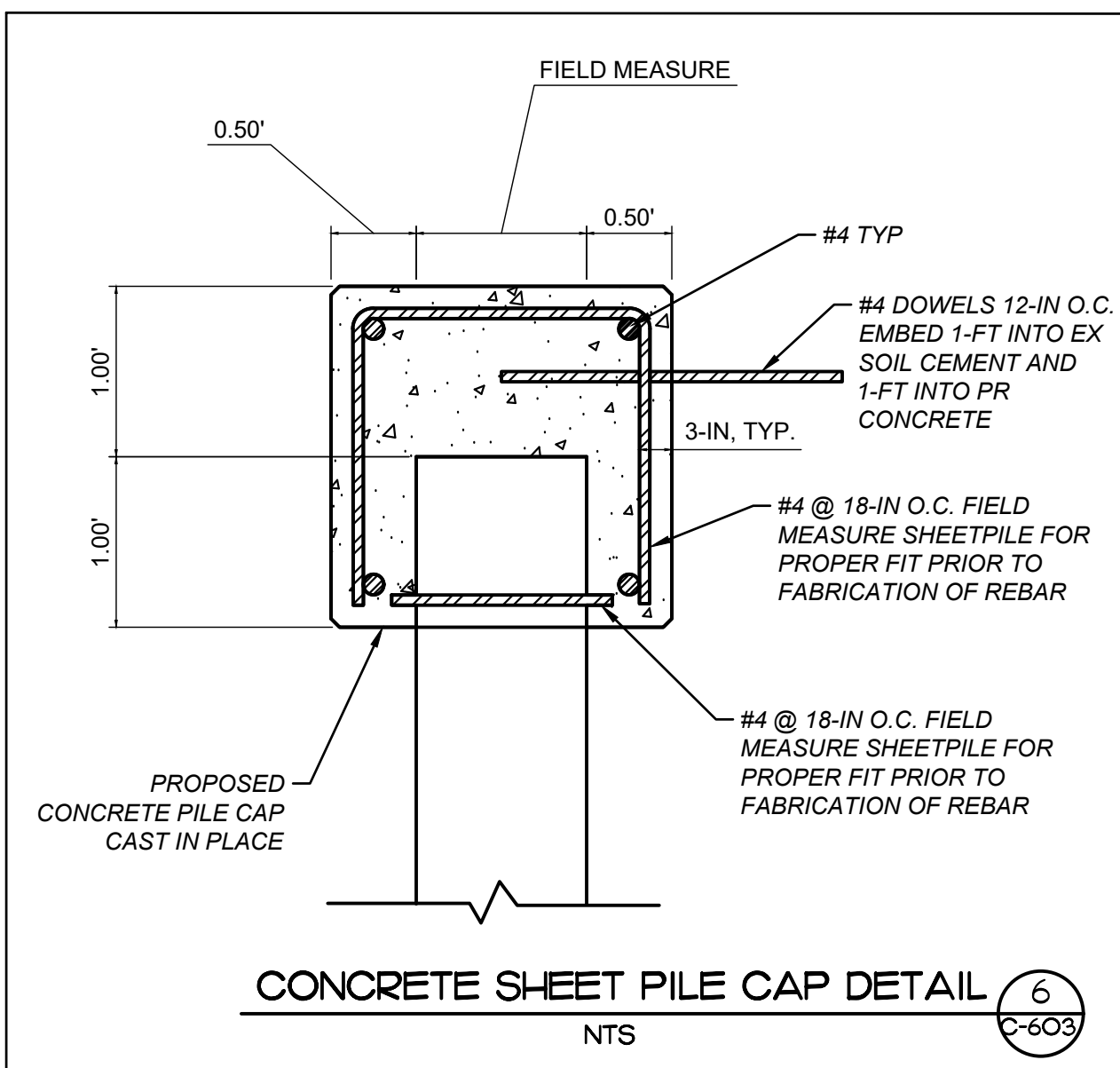
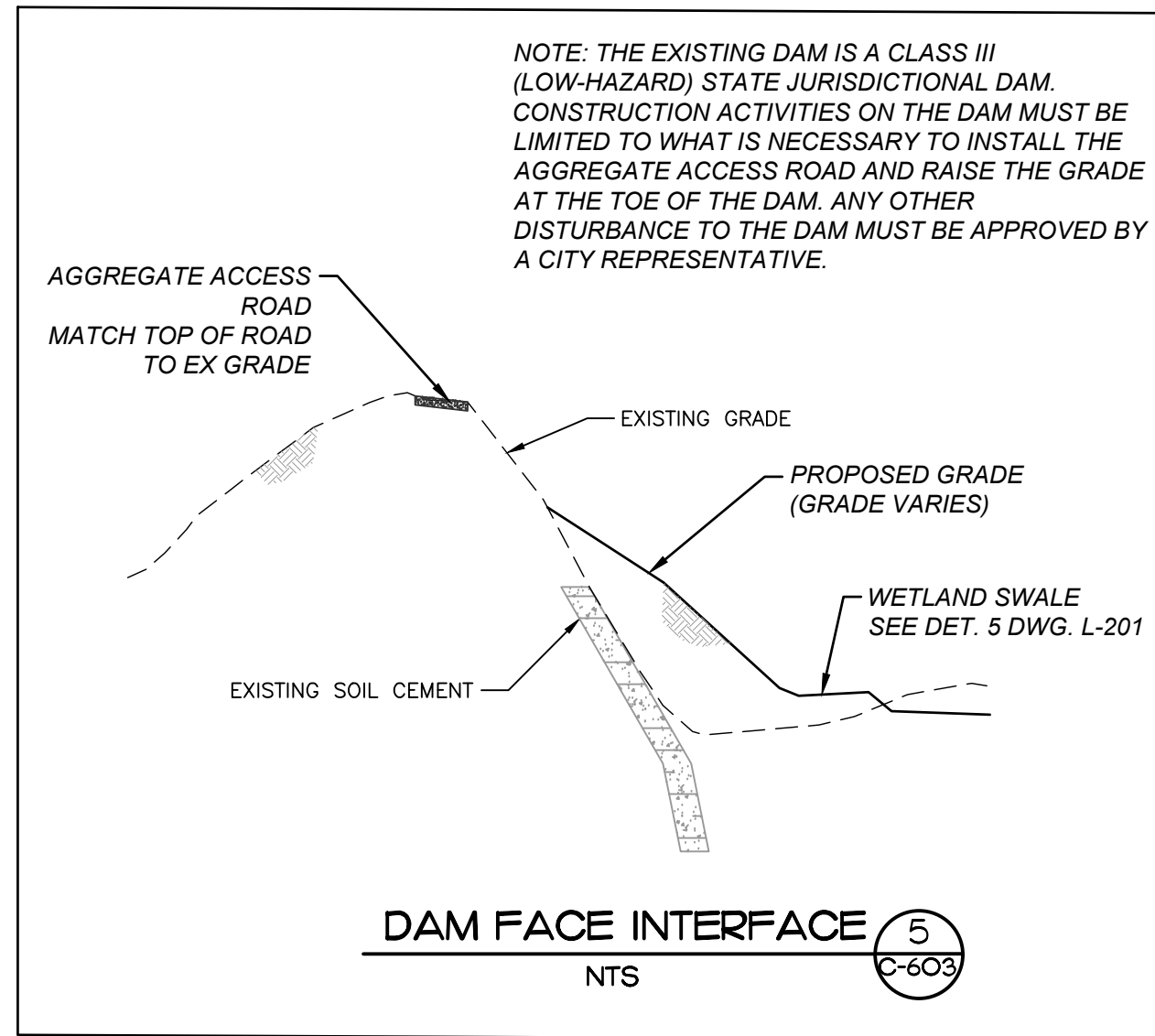
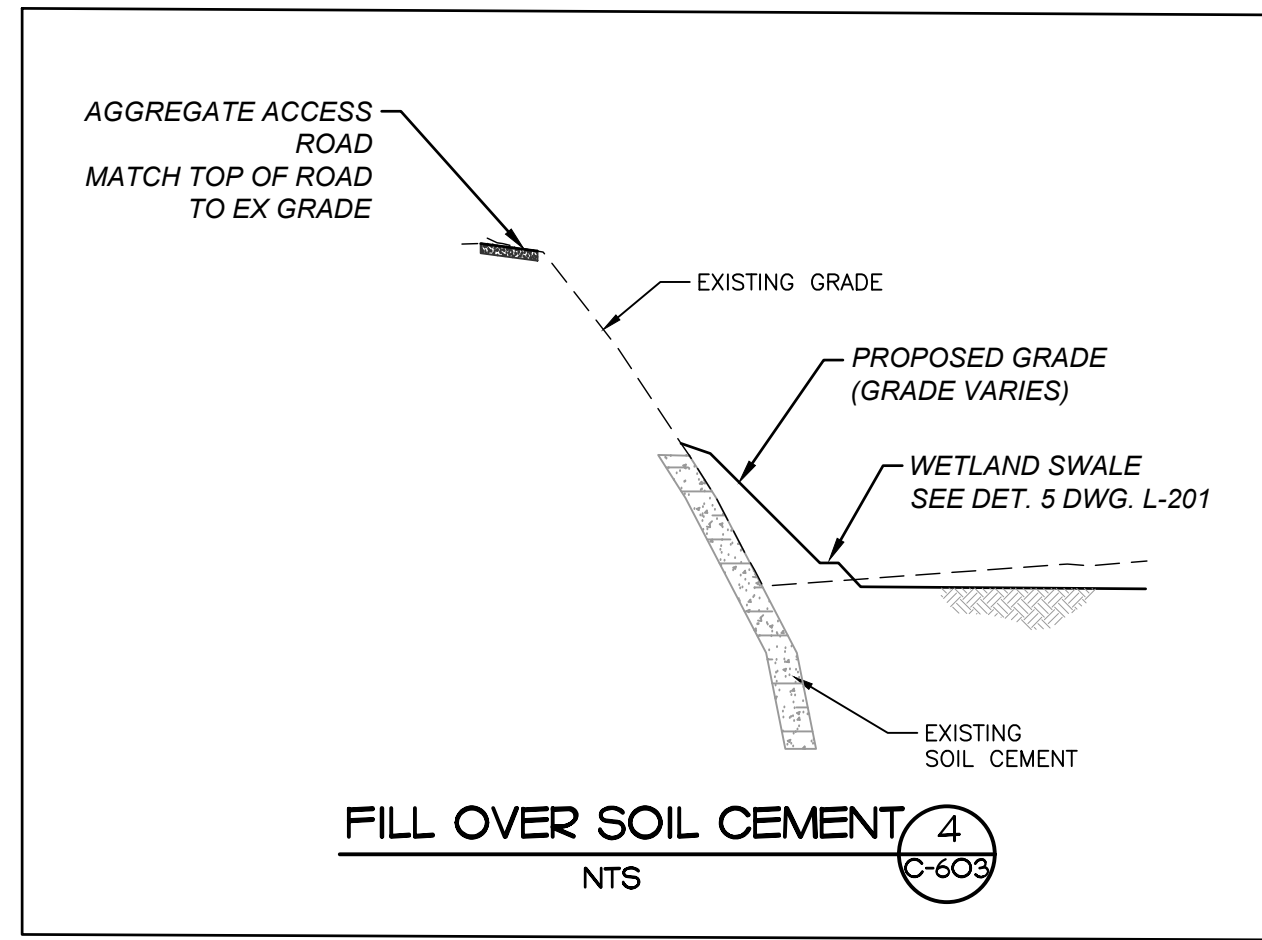

CONCEPT PHOTO

REV	REVISION DESCRIPTION	DATE	CHND	CHKD	APPR

CALL BEFORE YOU DIG

Know what's below.
Call before you dig.

CITY OF COLORADO SPRINGS
30 S. NEVADA AVE., SUITE 401
COLORADO SPRINGS, CO 80903
(719) 385-5980

Engineering | Architecture | Design-Build | Surveying | Planning | Geospatial Solutions
2480 W. 26TH AVE., UNIT B225 - DENVER COLORADO 80211
TEL. 303-751-0741, FAX 303-751-2581
www.merrick.com

PE STAMP

FOR AND ON BEHALF OF MERRICK & COMPANY

TITLE

SAND CREEK DETENTION POND NO. 2

CIVIL DETAILS

JOB NUMBER 65420975
DATE AUGUST 2024
DWG C-603
SHEET 23 of 51

THE USE OF THIS DRAWING IS LIMITED TO THE PROJECT AND SITE SPECIFICALLY IDENTIFIED THEREON. ANY REUSE OF THIS DRAWING FOR ANY OTHER PROJECT, REUSE OR MODIFICATION OF ANY INFORMATION NOT A PART OF THIS DRAWING IS PROHIBITED. THE USER SHALL BE RESPONSIBLE FOR OBTAINING ALL NECESSARY PERMITS AND APPROVALS. THE USER SHALL BE RESPONSIBLE FOR OBTAINING ALL NECESSARY PERMITS AND APPROVALS. THE USER SHALL BE RESPONSIBLE FOR OBTAINING ALL NECESSARY PERMITS AND APPROVALS.

File Location: Q:\Denver_North\Projects\City of Colorado Springs\Sand Creek Pond No. 2\CAD\CAD\09\0975-Flood_Sign_Detail.dwg Plot Date: 8/26/2024 4:41 PM Last Saved By: TIMMCMULLEN

TYPICAL SINGLE BRACKET

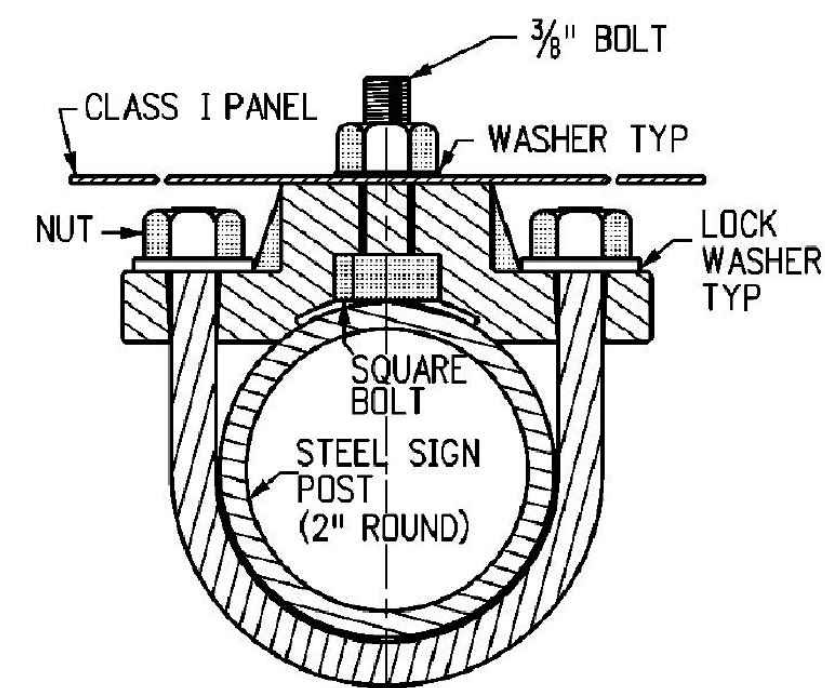

TYPICAL ROUND STEEL POLE SECTION

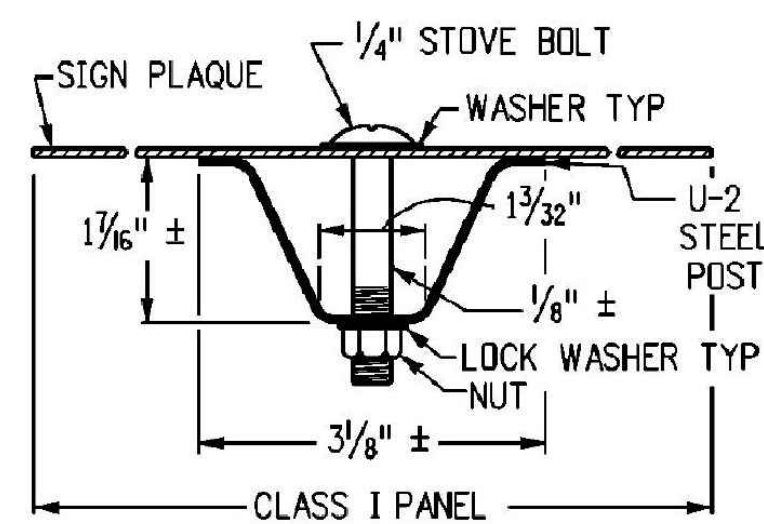

TYPICAL U-2 POST SECTION

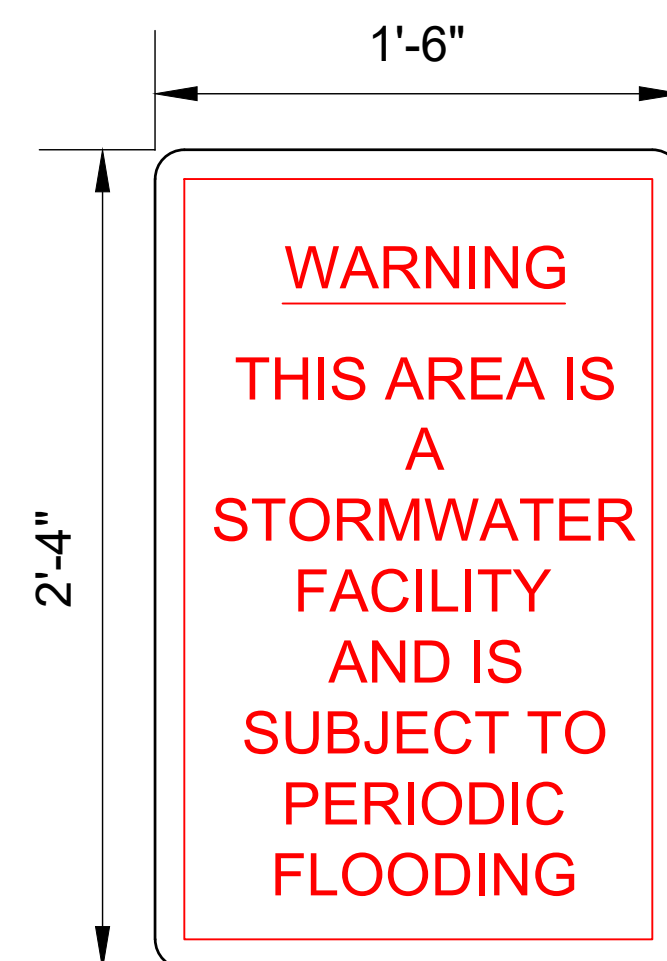

SIGN FACE

GENERAL NOTES

1. TIMBER SIGN POSTS MAY ONLY BE USED FOR TEMPORARY SIGNAGE DURING CONSTRUCTION. TUBULAR STEEL SHALL BE USED FOR PERMANENT INSTALLATIONS.
2. CLASS I SIGN PANELS ARE ALL THOSE THAT DO NOT REQUIRE BACKING ZEES. CLASS I PANELS SHALL GENERALLY BE 0.100" MINIMUM THICKNESS SINGLE SHEET ALUMINUM, BUT 0.080" THICKNESS MAY BE USED FOR SIGN PANELS WHERE BOTH THE HORIZONTAL AND VERTICAL DIMENSIONS ARE LESS THAN 36 IN.
3. CLASS I SIGN PANELS SHALL BE FASTENED TO THE U-2 POST WITH 2- IN. STOVE BOLTS AND TO TIMBER POSTS WITH 2- IN. MACHINE BOLTS. SEE STANDARD PLANS S-614-20 AND S-614-22 FOR EXCEPTIONS.
4. A WASHER SHALL BE PLACED BETWEEN THE BOLT HEAD AND THE FACE OF THE SIGN PANEL. A 1 IN. DIA. WASHER SHALL BE PLACED UNDER THE NUT ON THE BACK OF THE TIMBER POST.
5. BOLTS, NUTS AND WASHERS SHALL BE GALVANIZED OR CADMIUM PLATED.
6. ALL SIGNS SHALL BE FABRICATED USING RETROREFLECTIVE SHEETING CONFORMING TO ASTM D4956.
7. PLACE SIGNS ACCORDING TO PLANS, WITH THE SIGN POST 4' FROM THE NEAREST EDGE OF ACCESS ROAD
8. U-2 POSTS MAY ONLY BE USED FOR DELINEATORS, MILE MARKERS AND STRUCTURE NUMBER PLAQUES. "U" SHAPE STEEL POSTS SHALL BE A UNIFORM FLANGED CHANNEL SECTION MADE FROM HOT ROLLED STRUCTURAL STEEL, RE-ROLLED RAIL STEEL, OR NEW BILLET STEEL HAVING A MINIMUM YIELD STRENGTH OF AT LEAST 30,000 PSI, AND A MINIMUM TENSILE STRENGTH OF AT LEAST 50,000 PSI. "U" SHAPE POSTS SHALL WEIGH 2 LBS/FT, EXCEPT THAT A MILL TOLERANCE OF MINUS 3 % OF THE WEIGHT OF ANY ONE POST WILL BE ALLOWED. "U" SHAPE POSTS SHALL HAVE 1/2 IN. HOLES DRILLED OR PUNCHED ON 1 IN. OR 2 IN. CENTERS FOR THE TOP 4 FEET OF THE POST AS A MINIMUM, WITH THE FIRST HOLE 1 IN. FROM THE TOP OF THE POST. COLOR OF POSTS SHALL BE INTERSTATE GREEN.
9. VERTICAL SPACING BETWEEN PANELS ON THE SAME POST SHALL BE 1 IN. TO 1 IN.
10. SIGNS MUST BE MINIMUM OF 3 SQUARE FEET, FABRICATED OF DURABLE MATERIALS (SUCH AS METAL OR PLASTIC) AND USE RED LETTERING ON A WHITE BACKGROUND.

Computer File Information		Sheet Revisions		Colorado Department of Transportation 2829 W. Howard Pl. Denver, CO 80204 Phone: 303-757-9436 FAX: 303-757-9219 Traffic & Safety Engineering	CLASS I SIGNS Issued By: Traffic & Safety Engineering Branch July 31, 2019	STANDARD PLAN NO.	
Creation Date: 07/04/12		Date:	Comments:			S-614-2	Standard Sheet No. 1 of 1
Created By: KCM				MKB	Project Sheet Number:		
Last Modification Date: 07/31/19							
Last Modified By: EBUTTA							
CAD Ver.: MicroStation V8 Scale: Not to Scale Units: English							

REV	REVISION DESCRIPTION	DATE	CHND	CHKD	APPR

CALL BEFORE YOU DIG

**Know what's below.
Call before you dig.**

CITY OF COLORADO SPRINGS
 30 S. NEVADA AVE., SUITE 401
 COLORADO SPRINGS, CO 80903
 (719) 385-5980

MERRICK®
 Engineering | Architecture | Design-Build | Surveying | Planning | Geospatial Solutions
 2480 W. 26TH AVE., UNIT B225 - DENVER COLORADO 80211
 TEL: 303-751-0741, FAX 303-751-2581
 www.merrick.com

PE STAMP

FOR AND ON BEHALF OF MERRICK & COMPANY

TITLE



SAND CREEK DETENTION POND NO. 2

CIVIL DETAILS

JOB NUMBER: 65420975
 DATE: AUGUST 2024
 DWG: **C-604**
 SHEET: 24 of 51

THE USE OF ANY ENGINE, ELECTRONIC, MEASUREMENT OR INSTRUMENTATION IS AN INSTRUMENT OF SERVICE PROVIDED BY ARCHITERRA GROUP, INC. (ARCHITERRA) FOR THIS PROJECT. IT IS NOT INTENDED OR REPRESENTED TO BE SUITABLE FOR REUSE IN WHOLE OR IN PART OR FOR THE EXTENSION OF THE PROJECT OR FOR ANY OTHER PROJECT. REUSE OR MODIFICATION OF ANY INFORMATION NOT A PART OF THIS INSTRUMENT WITHOUT THE WRITTEN CONSENT OF ARCHITERRA GROUP, INC. IS PROHIBITED. ARCHITERRA GROUP, INC. SHALL BE THE SOLE RESPONSIBLE PARTY FOR ANY DAMAGE TO THE PROJECT OR TO THE USER'S DATA.

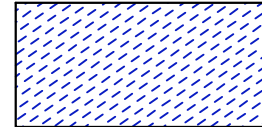
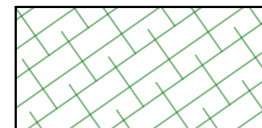
SEEDING AND WETLANDS LEGEND

-  WETLAND PLUGS
-  WETLAND/RIPARIAN SEED
-  UPLAND SEED

WETLAND PLUG SCHEDULE

QTY	LATIN NAME	COMMON NAME	SIZE	REMARKS
4,410	<i>Carex aquatilis</i>	Water sedge	10 cu. in. plug	98 ct. flat
4,410	<i>Carex emoryi</i>	Emory sedge	10 cu. in. plug	98 ct. flat
4,312	<i>Carex nebrascensis</i>	Nebraska sedge	10 cu. in. plug	98 ct. flat
4,312	<i>Carex pellita (lanuginosa)</i>	Woolly sedge	10 cu. in. plug	98 ct. flat
4,312	<i>Distichlis spicata</i>	Inland saltgrass	10 cu. in. plug	98 ct. flat
4,312	<i>Eleocharis palustris</i>	Common spikerush	10 cu. in. plug	98 ct. flat
4,312	<i>Juncus articus</i>	Baltic rush	10 cu. in. plug	98 ct. flat
4,312	<i>Juncus torreyi</i>	Torrey's rush	10 cu. in. plug	98 ct. flat
4,312	<i>Panicum virgatum</i>	Switchgrass	10 cu. in. plug	98 ct. flat
4,312	<i>Schoenoplectus acutus</i>	Hardstem bulrush	10 cu. in. plug	98 ct. flat
4,312	<i>Schoenoplectus tabernaemontani</i>	Softstem bulrush	10 cu. in. plug	98 ct. flat
4,312	<i>Scirpus pungens</i>	Common three-square	10 cu. in. plug	98 ct. flat
4,312	<i>Scirpus microcarpus</i>	Panicled bulrush	10 cu. in. plug	98 ct. flat
4,312	<i>Spartina pectinate</i>	Prairie cordgrass	10 cu. in. plug	98 ct. flat

- NOTES:**
- RIP AND RESEED CONSTRUCTION ACCESS ROUTES.
 - COORDINATE WITH OWNER'S REPRESENTATIVE FOR LOCATIONS OF SEED AND WETLANDS.
 - SEE WETLAND PLUG SCHEDULE (THIS SHEET) FOR WETLAND PLUGS. SEE SPECIFICATIONS FOR SEED MIXES.
 - WETLAND LAYOUT MAY NEED TO BE ADJUSTED BASED ON SOIL HYDROLOGY AFTER CONSTRUCTION. COORDINATE LAYOUT WITH OWNER'S REPRESENTATIVE.
 - WETLAND PLUGS SHALL BE PLANTED IN GROUPINGS OF NO LESS THAN 100 OF THE SAME SPECIES. THE INTENT IS TO CREATE A NATURAL CHARACTER BY PLANTING ORGANICALLY SHAPED GROUPINGS OF WETLAND PLANTS, RATHER THAN RIGID, GEOMETRIC GROUPS OF PLANTS. COORDINATE WITH OWNER'S REPRESENTATIVE FOR LAYOUT.
 - AN ADDITIONAL 12 FLATS OF WETLAND PLUGS (1,176 PLUGS) WILL BE INSTALLED IN GROUPINGS OF 30-40 THROUGHOUT AREAS COVERED BY THE WETLAND/RIPARIAN SEED MIX. COORDINATE WITH OWNER'S REPRESENTATIVE FOR LOCATIONS.

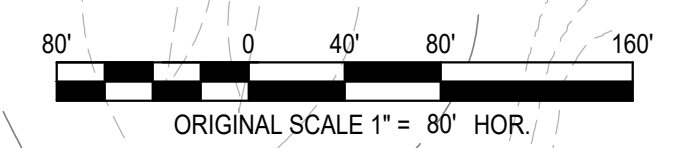
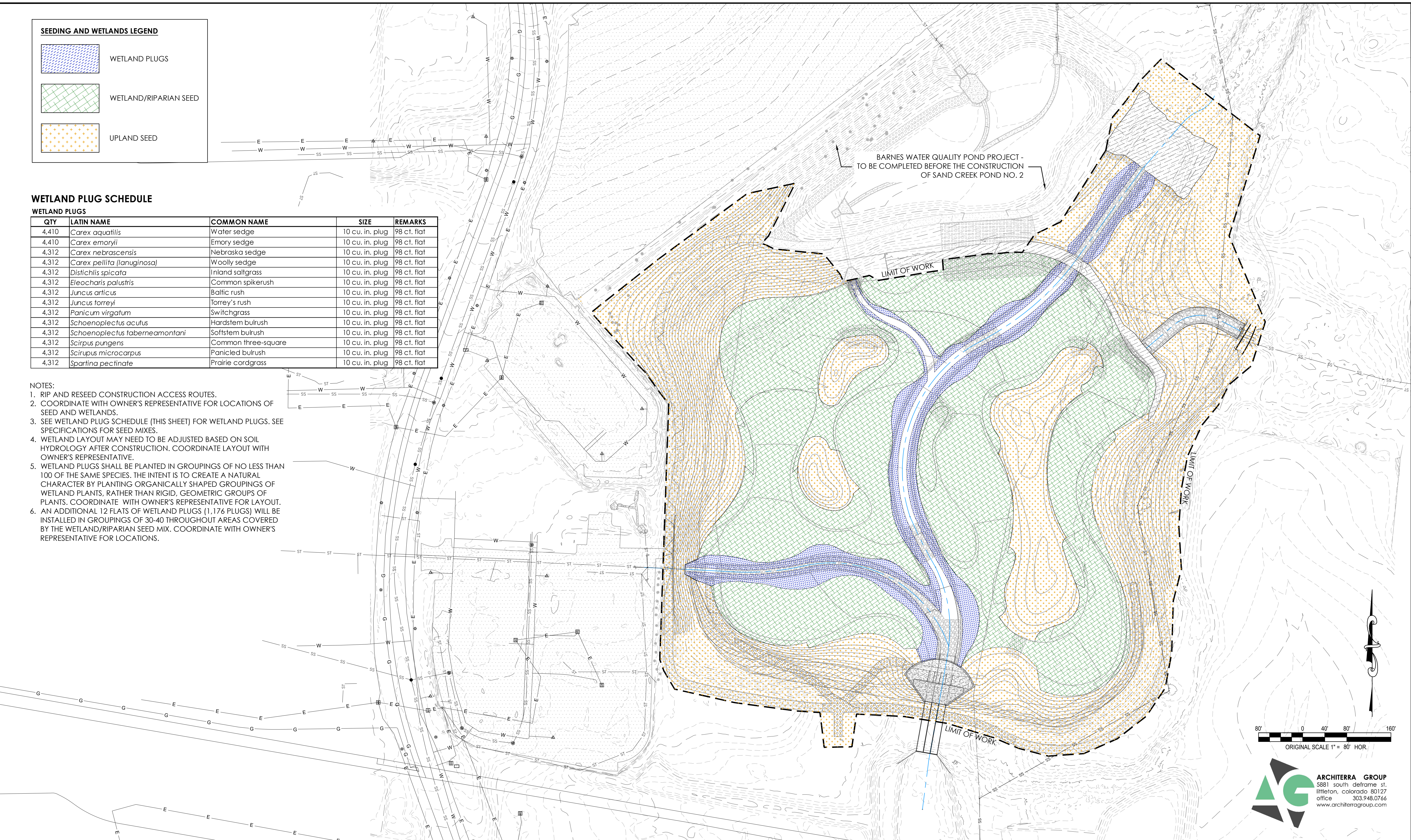

ARCHITERRA GROUP
 5881 south deframe st.
 littleton, colorado 80127
 office 303.948.0766
 www.architerragroup.com

REV	REVISION DESCRIPTION	DATE	CHND	CHKD	APPR



811
 Know what's below.
 Call before you dig.

CITY OF COLORADO SPRINGS
 30 S. NEVADA AVE., SUITE 401
 COLORADO SPRINGS, CO 80903
 (719) 385-5980



MERRICK
 Engineering | Architecture | Design-Build | Surveying | Planning | Geospatial Solutions
 2480 W. 26TH AVE., UNIT B225 - DENVER COLORADO 80211
 TEL. 303-751-0741, FAX 303-751-2581
 www.merrick.com

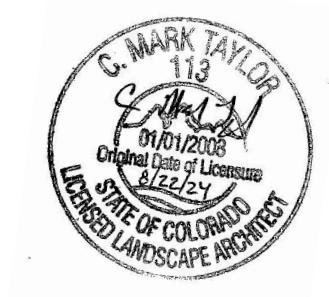

SAND CREEK DETENTION POND NO. 2

SEEDING AND WETLAND PLUGS PLAN

JOB NUMBER: 65420975
 DATE: AUGUST 2024
 DRAWING: L-100
 25 of 51

THE ANY OTHER EXISTING UTILITIES, ENCUMBRANCES, OR OBSTRUCTIONS ARE SHOWN BY DASHED LINES. CONTRACTOR SHALL VERIFY THE LOCATION AND DEPTH OF ALL UTILITIES PRIOR TO CONSTRUCTION. CONTRACTOR SHALL BE RESPONSIBLE FOR ANY DAMAGE TO UTILITIES OR OBSTRUCTIONS. CONTRACTOR SHALL BE RESPONSIBLE FOR OBTAINING ALL NECESSARY PERMITS AND APPROVALS. CONTRACTOR SHALL BE RESPONSIBLE FOR OBTAINING ALL NECESSARY PERMITS AND APPROVALS. CONTRACTOR SHALL BE RESPONSIBLE FOR OBTAINING ALL NECESSARY PERMITS AND APPROVALS.

- NOTES:**
1. LOCATION OF ALL PLANTS WILL BE APPROVED BY OWNER'S REPRESENTATIVE IN THE FIELD PRIOR TO PLANTING. CONTRACTOR SHALL STAKE TREE LOCATIONS AND LAY POTTED PLANTS ON SITE AT PROPOSED LOCATIONS FOR APPROVAL BY OWNER'S REPRESENTATIVE.
 2. SEE L-102 FOR PLANT SCHEDULE.
 3. SEE L-201 FOR PLANTING DETAILS.

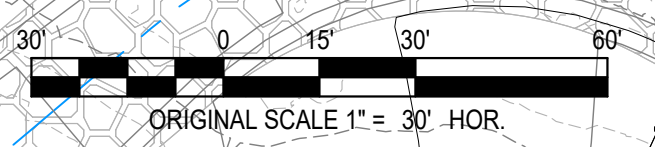
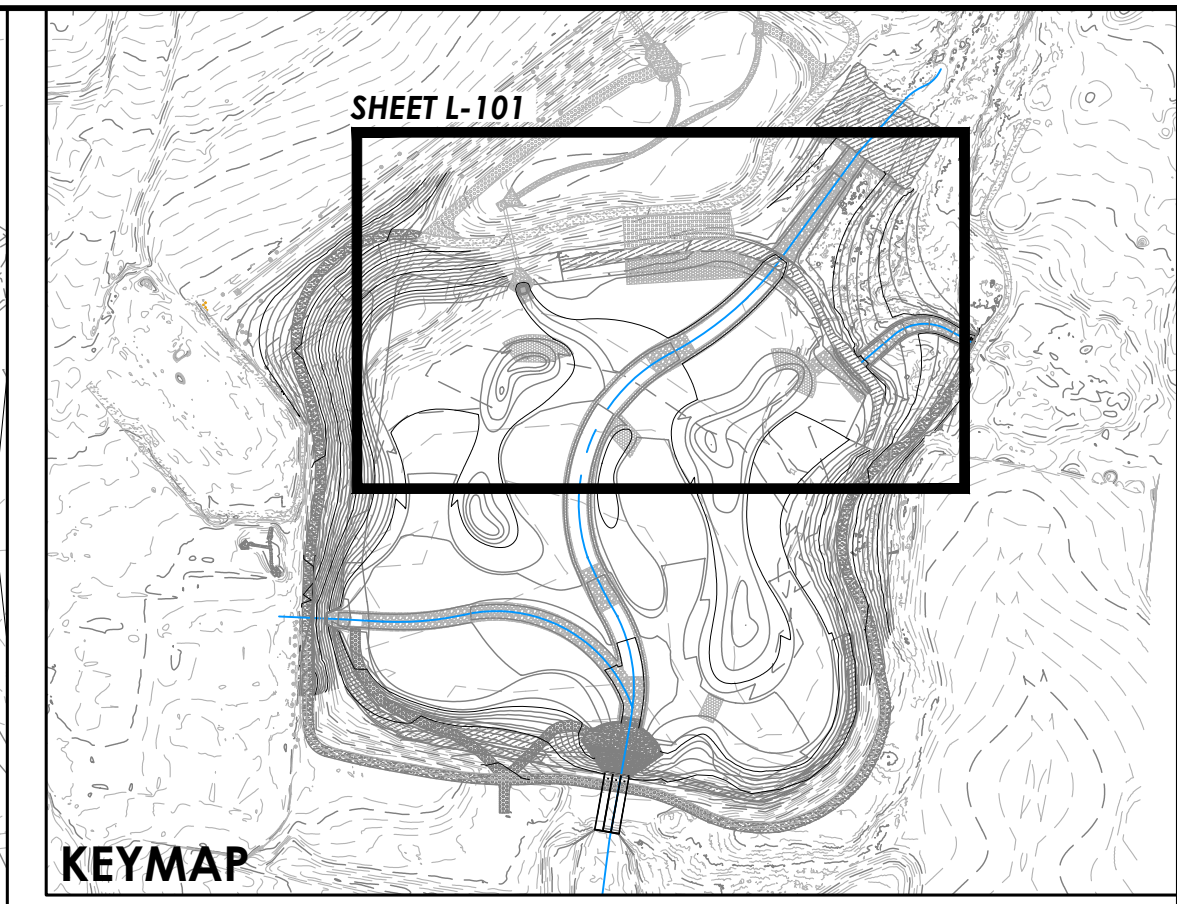
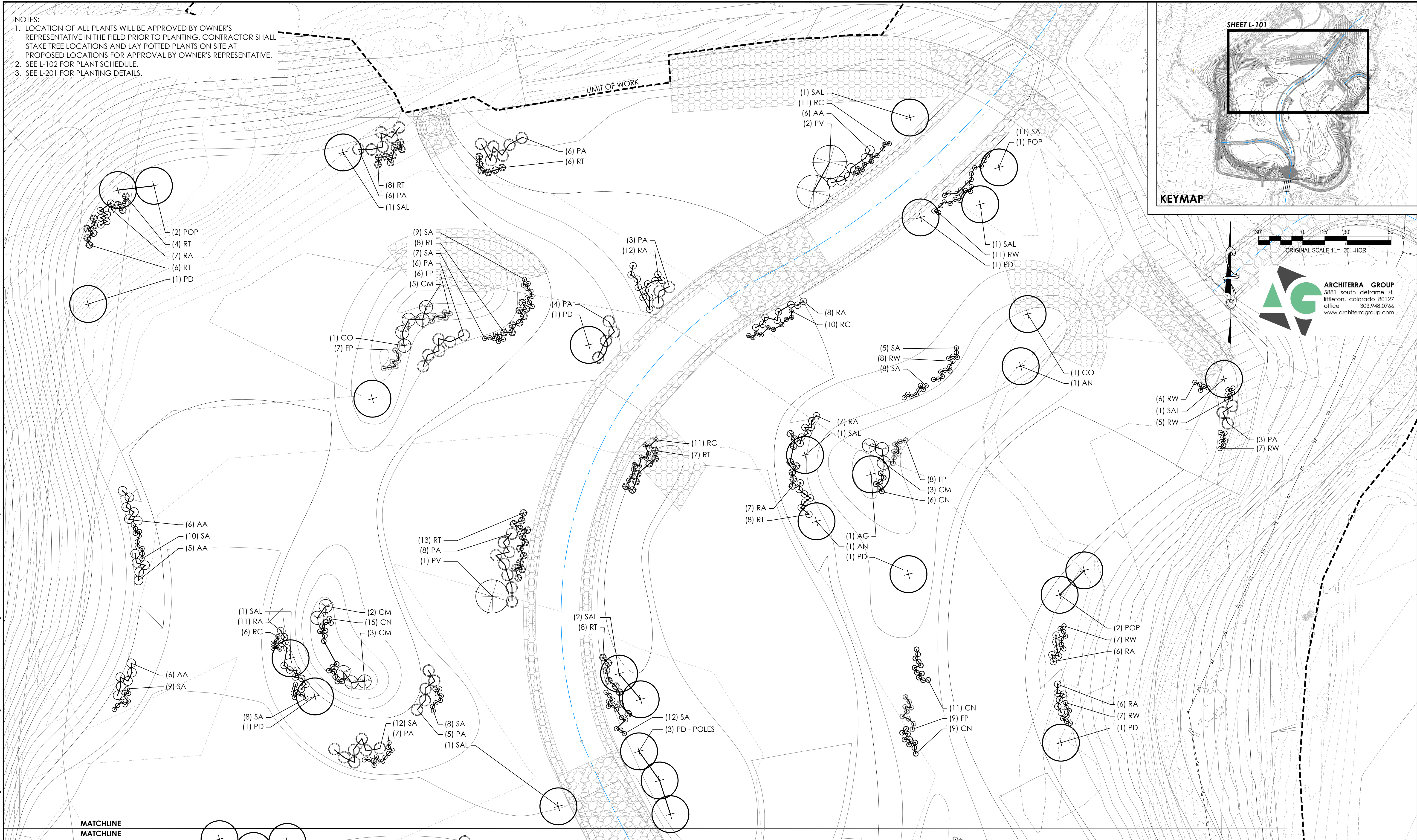

File Location: 2:\projects\106-Sand Creek Pond #2\Drawings - Technical\Construction Drawings\106 - Sand Creek Pond #2.DWG Plot Date: 8/22/2024 5:20 PM Last Saved By: MTALEFRICO

REV	REVISION DESCRIPTION	DATE	CHND	CHKD	APPR

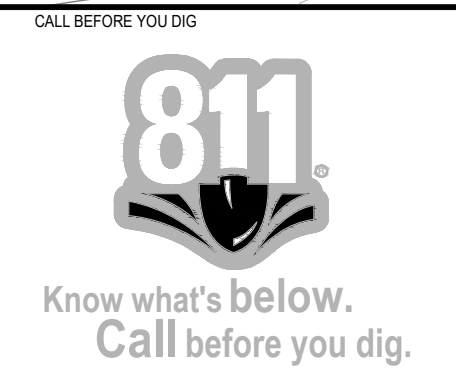

CITY OF COLORADO SPRINGS
 30 S. NEVADA AVE., SUITE 401
 COLORADO SPRINGS, CO 80903
 (719) 385-5980

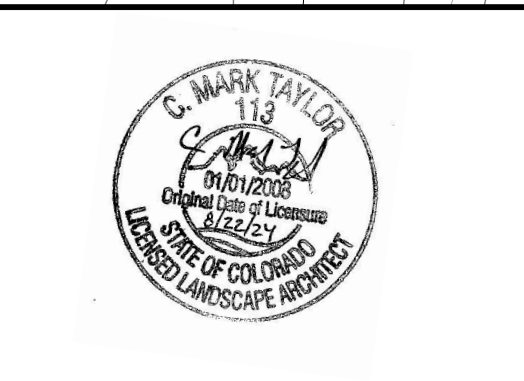

SAND CREEK DETENTION POND NO. 2
PLANTING PLAN

JOB NUMBER: 65420975
 DATE: AUGUST 2024
 DRAWING: L-101
 26 of 51

THIS AND ALL OTHERS ARE EXISTING AND NOT TO BE CONSIDERED AS PART OF THIS PROJECT. IT IS NOT INTENDED OR REPRESENTED TO BE SUITABLE FOR REUSE IN WHOLE OR IN PART OR EXTENSION OF THE PROJECT OR ON ANY OTHER PROJECT. REUSE OR MODIFICATION OF ANY INFORMATION NOT A FINISHED INSTRUMENT WITHOUT THE WRITTEN CONSENT OF MERRICK AND ASSOCIATES SHALL BE AT THE USER'S RISK. THE USER SHALL BE RESPONSIBLE FOR OBTAINING ALL NECESSARY PERMITS AND APPROVALS.

File Location: \\projects\2106-Sand Creek Pond #2 Drawings - Technical\Construction Drawings\2106 - Sand Creek Pond #2 Dwg Plot Date: 8/22/2024 5:22 PM Last Saved By: MTALEFRICO

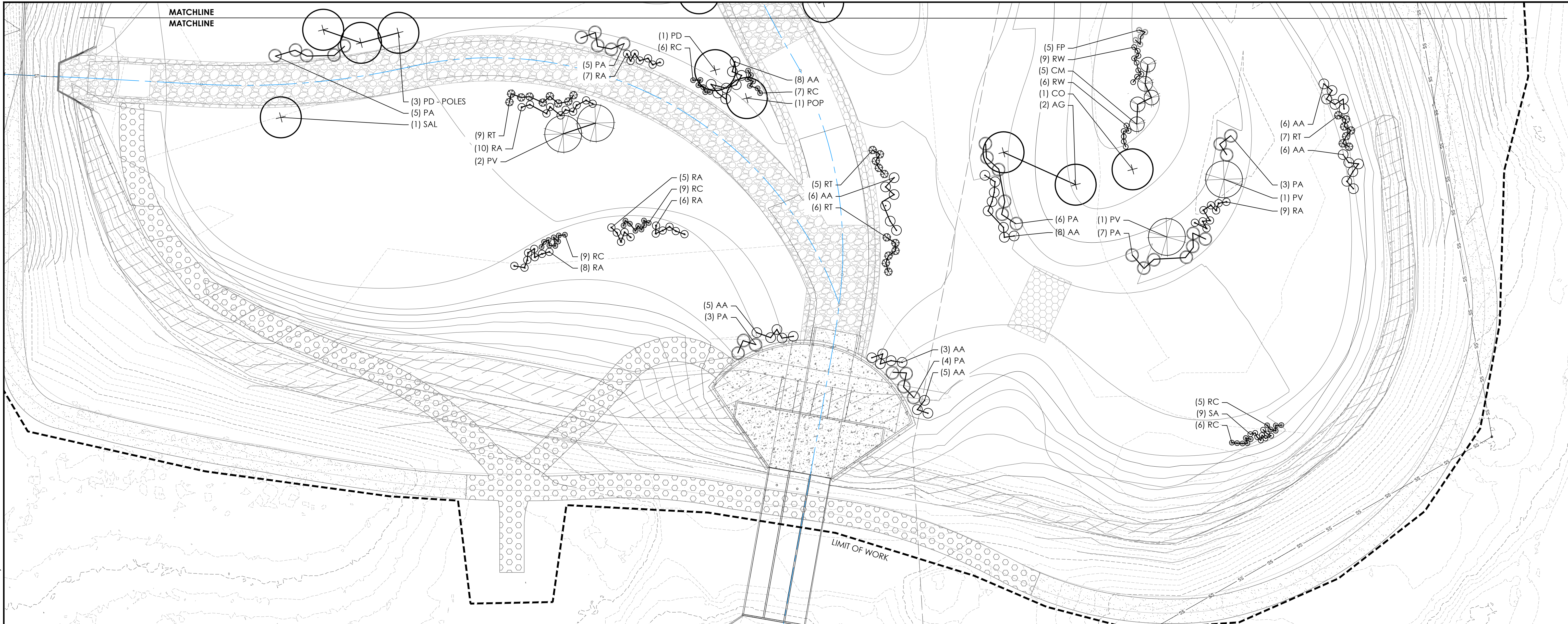

PLANT SCHEDULE

KEY	QTY	LATIN NAME	COMMON NAME	SIZE	REMARKS
AA	70	<i>Amelanchier alnifolia</i>	Saskatoon serviceberry	#5	Container
CM	18	<i>Cercocarpus montanus</i>	Mountain mahogany	#5	Container
CN	41	<i>Chrysothamnus nauseosus</i>	Rubber rabbitbrush	#5	Container
FP	35	<i>Fallugia paradoxa</i>	Apache plume	#5	Container
PA	81	<i>Prunus americana</i>	Wild plum	#5	Container
PV	7	<i>Prunus virginiana</i>	Chokecherry	#5	Container
RT	95	<i>Rhus trilobata</i>	Skunkbrush sumac	#5	Container
RA	109	<i>Ribes aureum</i>	Golden currant	#5	Container
RC	80	<i>Ribes cereum</i>	Wax currant	#5	Container
RW	66	<i>Rosa woodsii</i>	Wood's rose	#5	Container
SA	108	<i>Symphoricarpos albus</i> or <i>S. occidentalis</i>	Snowberry	#5	Container

KEY	QTY	LATIN NAME	COMMON NAME	SIZE	REMARKS
AG	3	<i>Acer glabrum</i>	Rocky Mountain Maple	2" Caliper	B&B
AN	2	<i>Acer negundo</i>	Box Elder	2" Caliper	B&B
CO	3	<i>Celtis occidentalis</i>	Common Hackberry	2" Caliper	B&B
POP	6	<i>Populus angustifolia</i>	Narrow-leaved cottonwood	2" Caliper	B&B
PD	7	<i>Populus deltoides monilifera</i>	Plains cottonwood	2" Caliper	B&B
PD	6	<i>Populus deltoides monilifera</i>	Plains cottonwood	Live cutting	Poles
SAL	10	<i>Salix amygdaloides</i>	Peachleaf willow	2" Caliper	B&B

ARCHITERRA GROUP
 5881 south deframe st.
 littleton, colorado 80127
 office 303.948.0766
 www.architerragroup.com

- NOTES:**
1. LOCATION OF ALL PLANTS WILL BE APPROVED BY OWNER'S REPRESENTATIVE IN THE FIELD PRIOR TO PLANTING. CONTRACTOR SHALL STAKE TREE LOCATIONS AND LAY POTTED PLANTS ON SITE AT PROPOSED LOCATIONS FOR APPROVAL BY OWNER'S REPRESENTATIVE.
 2. SEE L-201 FOR PLANTING DETAILS.

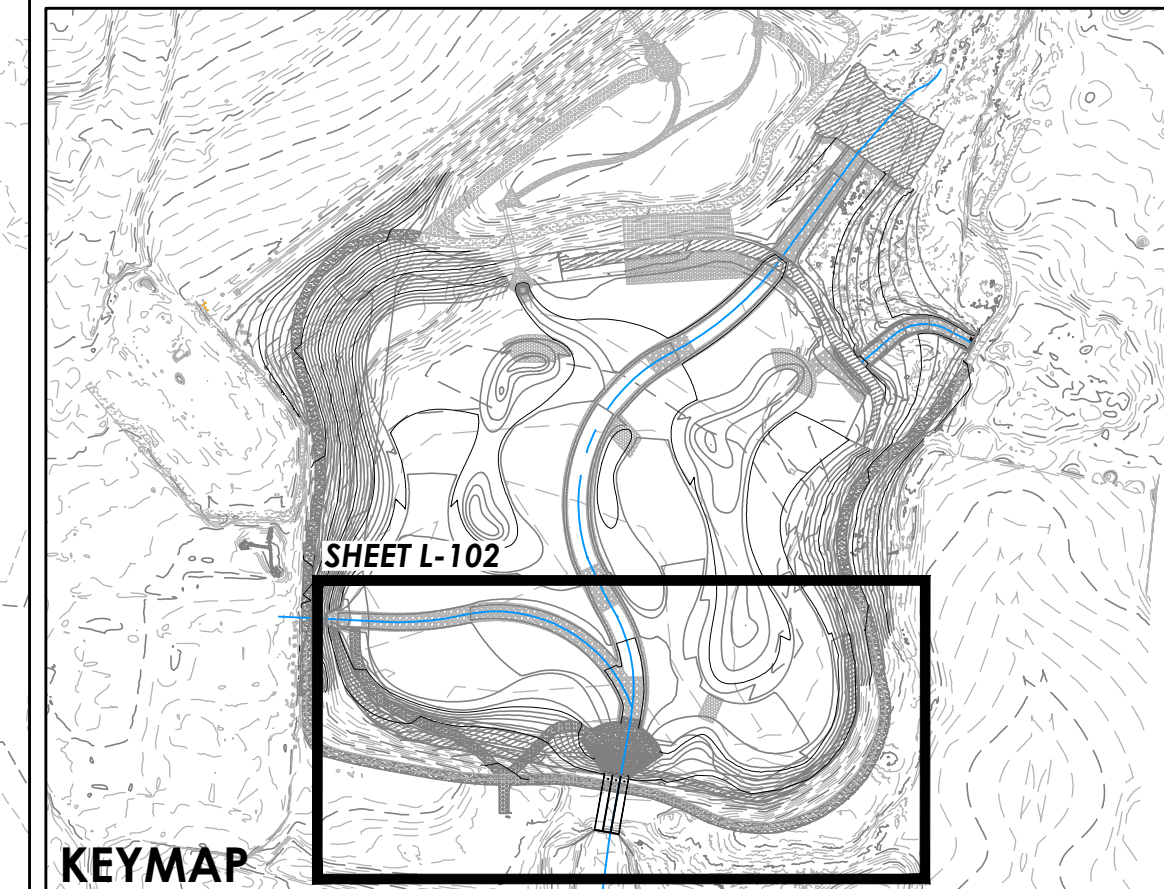

REV	REVISION DESCRIPTION	DATE	CHND	CHKD	APPR

CALL BEFORE YOU DIG

811
 Know what's below.
 Call before you dig.

CITY OF COLORADO SPRINGS
 30 S. NEVADA AVE., SUITE 401
 COLORADO SPRINGS, CO 80903
 (719) 385-5980

MERRICK
 Engineering | Architecture | Design-Build | Surveying | Planning | Geospatial Solutions
 2480 W. 26TH AVE., UNIT B225 - DENVER COLORADO 80211
 TEL. 303-751-0741, FAX 303-751-2581
 www.merrick.com

C. MARK TAYLOR
 118
 C. Mark Taylor
 State of Colorado
 LICENSED LANDSCAPE ARCHITECT

SAND CREEK DETENTION POND NO. 2

PLANTING PLAN

JOB NUMBER 65420975
 DATE AUGUST 2024
 DRAWING L-102
 27 of 51

THE ANY CHANGE IN EXISTING MEDIA OR INSTRUMENTS OF SERVICE, PROVIDED BY ARCHITECT AND COMPANY FOR A SERVICE PROJECT, REUSE OR MODIFICATION OF ANY INSTRUMENT OR REPRESENTATION TO BE SUITABLE FOR REUSE IN WHOLE OR IN PART OR EXTENSION OF THE PROJECT OR ON ANY OTHER PROJECT. ANY SUCH REUSE OR MODIFICATION OF ANY INSTRUMENT OR REPRESENTATION SHALL BE AT THE USER'S RISK AND WITHOUT LIABILITY TO ARCHITECT AND COMPANY.

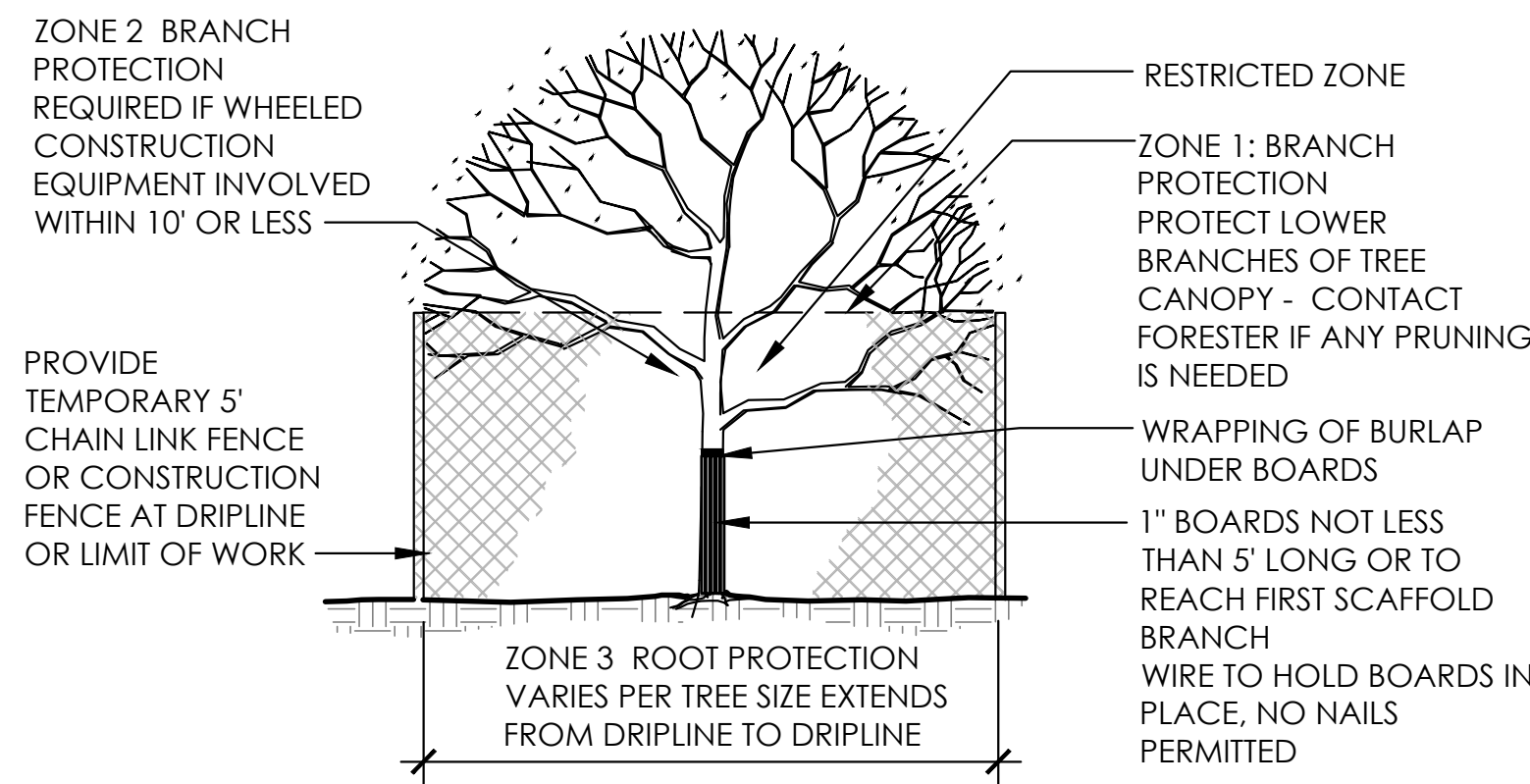

- NOTES:
1. ALL TREES TO RECEIVE ZONE 1, 2, & 3 PROTECTION.
 2. PROVIDE LARGEST PROTECTION ZONE BY EITHER USING DRIP LINE OR 1' Ø PER 1" DIAMETER AT BREAST HEIGHT (DBH), WHICHEVER IS LARGER.

1 TREE PROTECTION FENCING
L-201 SECTION / ELEVATION NTS

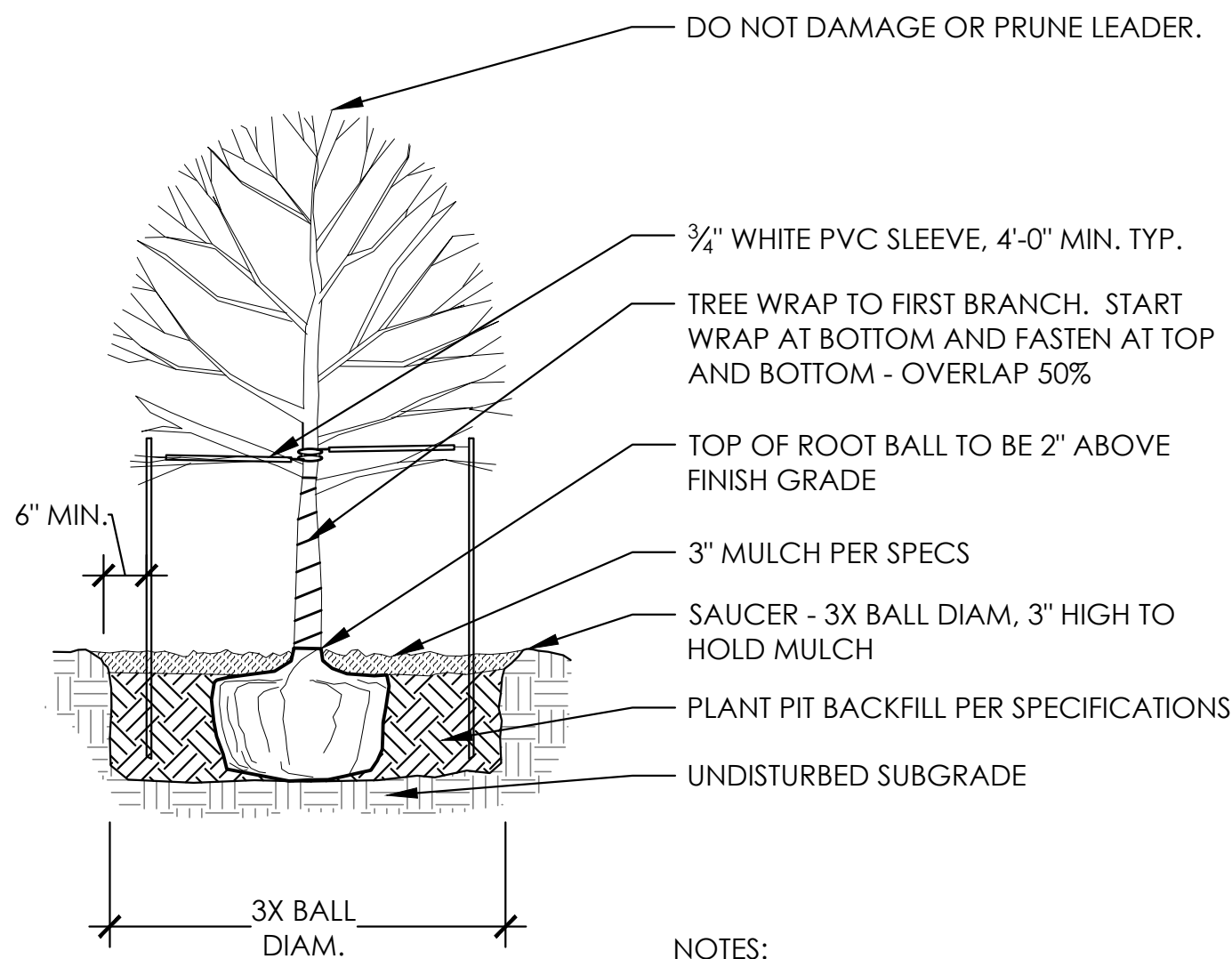

- NOTES:
1. SEE SPECS FOR ADDITIONAL PLANTING REQUIREMENTS.
 2. AFTER PLANT IS SET IN PLANT PIT, CUT AWAY AND REMOVE ALL WIRE AND OTHER RESTRAINING MATERIAL. TAKE CARE NOT TO DAMAGE ROOT BALL. FOLD BURLAP AWAY FROM THE TOP OF THE ROOTBALL.
 3. PLUMB AND ORIENT PLANTS FOR BEST APPEARANCE.

2 POLES - TREES UNDER 3" CAL.

3 POLES - TREES OVER 3" CAL.

2 DECIDUOUS TREE PLANTING
L-201 SECTION / ELEVATION NTS

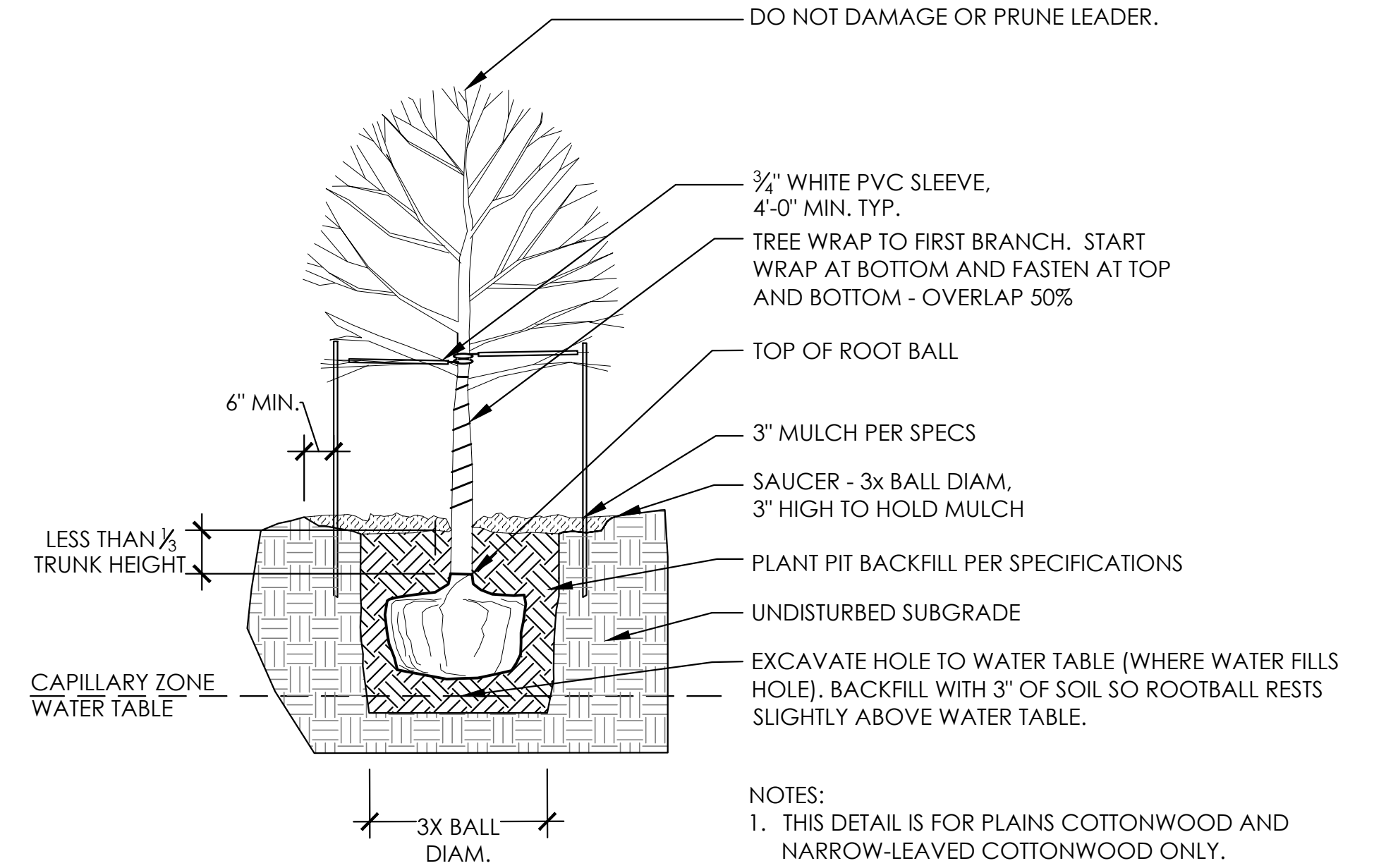

- NOTES:
1. THIS DETAIL IS FOR PLAINS COTTONWOOD AND NARROW-LEAVED COTTONWOOD ONLY.
 2. AFTER PLANT IS SET IN PLANT PIT, CUT AWAY AND REMOVE ALL WIRE AND OTHER RESTRAINING MATERIAL. TAKE CARE NOT TO DAMAGE ROOT BALL. FOLD BURLAP AWAY FROM THE TOP OF THE ROOTBALL.
 3. PLUMB AND ORIENT PLANTS FOR BEST APPEARANCE.

2 POLES - TREES UNDER 3" CAL.

3 POLES - TREES OVER 3" CAL.

3 DEEP COTTONWOOD TREE PLANTING
L-201 SECTION / ELEVATION NTS

- NOTES:
1. SEE SPECS FOR ADDITIONAL PLANTING REQUIREMENTS.
 2. AFTER PLANT IS SET IN PLANT PIT, CUT AWAY AND REMOVE ALL WIRE AND OTHER RESTRAINING MATERIAL. TAKE CARE NOT TO DAMAGE ROOT BALL. FOLD BURLAP AWAY FROM THE TOP OF THE ROOTBALL.
 3. PLUMB AND ORIENT PLANTS FOR BEST APPEARANCE.

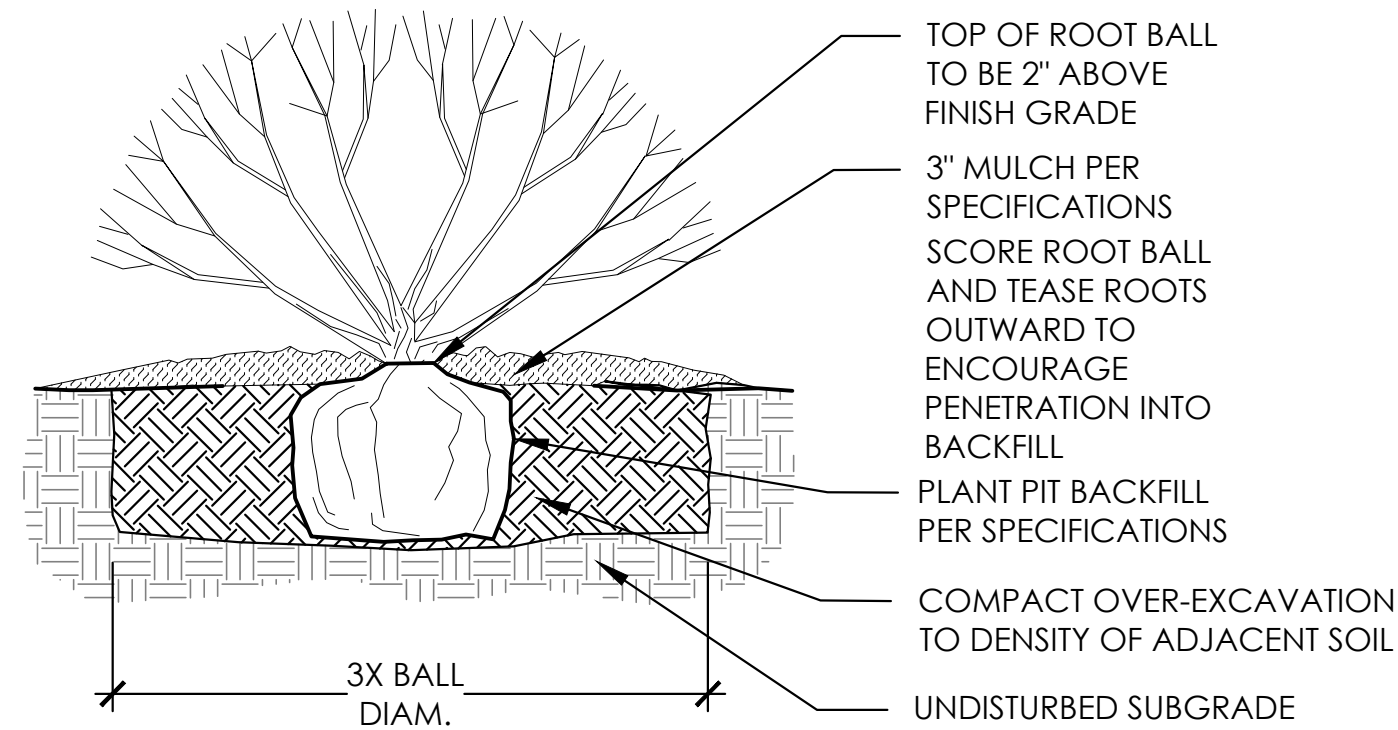

4 SHRUB PLANTING
L-201 SECTION / ELEVATION NTS

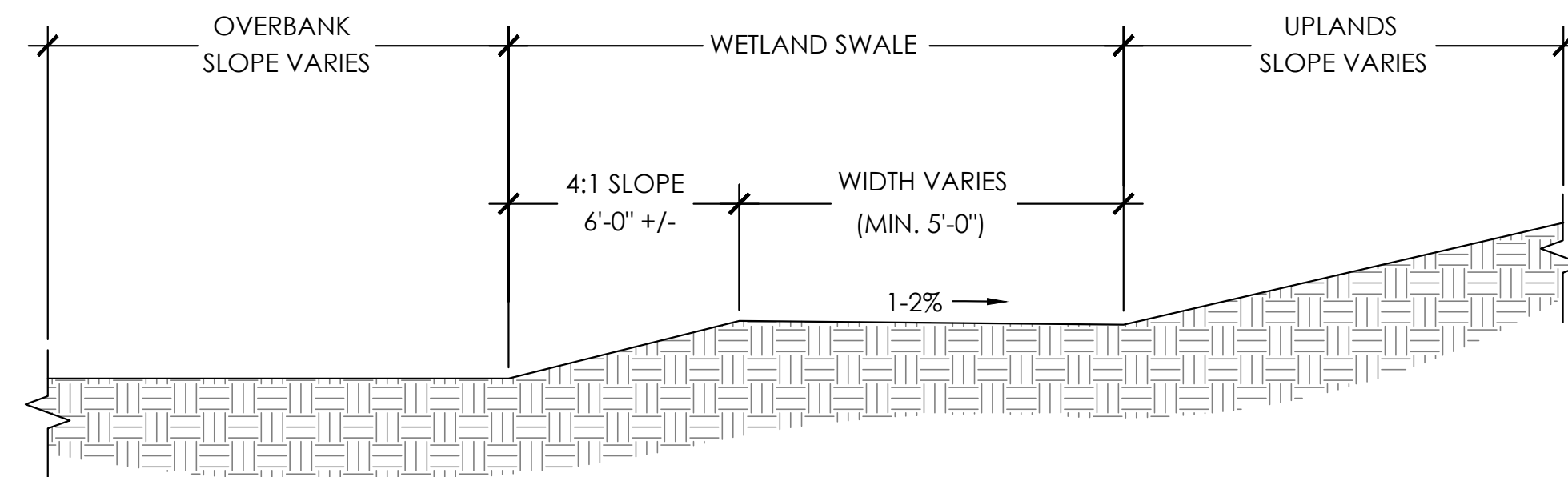

- NOTES:
1. THE DESIGN INTENT IS FOR THE WETLAND SWALES TO SLOW SURFACE WATER AND ENCOURAGE INFILTRATION INTO THE SOIL ALONG THE WETLAND SWALE BY MOVING WATER BACK TOWARDS THE UPLAND SLOPE AREAS.
 2. WETLAND SWALES SHOULD NOT HOLD WATER AND ARE DESIGNED TO DRAIN TO LOW POINTS. SEE GRADING PLANS FOR MORE INFORMATION.
 3. WETLAND SWALES TO HAVE LONGITUDINAL SLOPE OF APPROXIMATELY 1%, GENERALLY DRAINING NORTH TO SOUTH.

5 TYPICAL WETLAND SWALE
L-201 SECTION NTS



REV	REVISION DESCRIPTION	DATE	CHND	CHKD	APPR



CITY OF COLORADO SPRINGS
 30 S. NEVADA AVE., SUITE 401
 COLORADO SPRINGS, CO 80903
 (719) 385-5980



SAND CREEK DETENTION POND NO. 2

PLANTING DETAILS

JOB NUMBER	65420975
DATE	AUGUST 2024
DRAWING	L-201
28	of 51

THE USE OF THESE AESTHETIC TREATMENTS IS AN INDICATION OF SERVICE PROVIDED BY MERRICK AND COMPANY FOR A DESIGN PROJECT. IT IS NOT INTENDED OR REPRESENTED TO BE SUITABLE FOR REUSE IN WHOLE OR IN PART OR FOR EXTENSION OF THE PROJECT OR ON ANY OTHER PROJECT. REUSE OR MODIFICATION OF ANY INFORMATION NOT A FINISHED INSTRUMENT WITHOUT THE PRIOR EXPRESS WRITTEN CONSENT OF MERRICK AND COMPANY SHALL BE AT THE USER'S RISK. THESE AESTHETIC TREATMENTS ARE NOT TO BE USED IN CONJUNCTION WITH ANY OTHER AESTHETIC TREATMENTS.

File Location: C:\projects\12106-Sand Creek Pond #2 Drawings - Technical\Construction Drawings\12106 - Sand Creek Pond #2 Architectural Details.dwg Plot Date: 8/22/2024 4:52 PM Last Saved By: MT-ALERICO

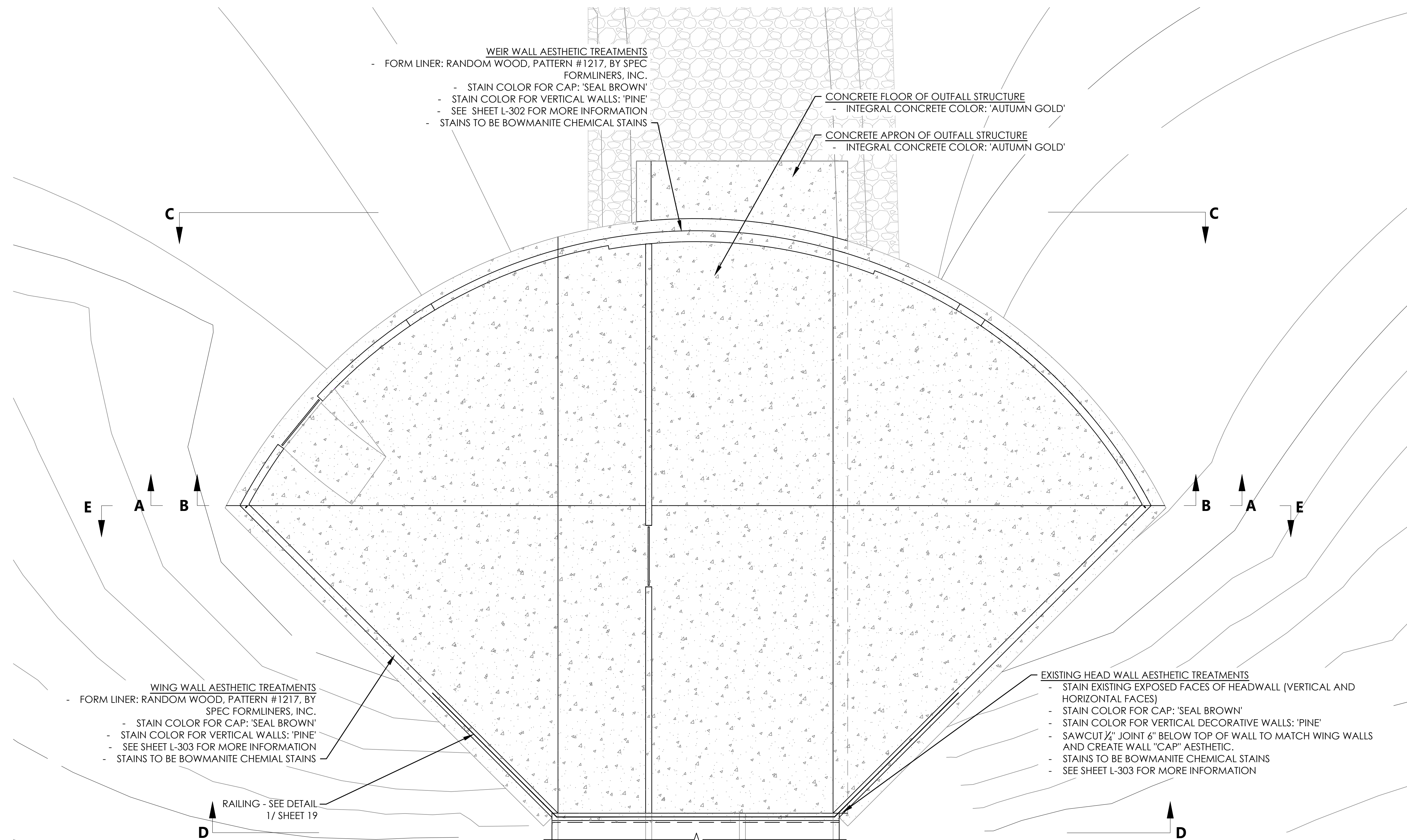

WEIR WALL AESTHETIC TREATMENTS

- FORM LINER: RANDOM WOOD, PATTERN #1217, BY SPEC FORMLINERS, INC.
- STAIN COLOR FOR CAP: 'SEAL BROWN'
- STAIN COLOR FOR VERTICAL WALLS: 'PINE'
- SEE SHEET L-302 FOR MORE INFORMATION
- STAINS TO BE BOWMANITE CHEMICAL STAINS

CONCRETE FLOOR OF OUTFALL STRUCTURE
- INTEGRAL CONCRETE COLOR: 'AUTUMN GOLD'

CONCRETE APRON OF OUTFALL STRUCTURE
- INTEGRAL CONCRETE COLOR: 'AUTUMN GOLD'

WING WALL AESTHETIC TREATMENTS

- FORM LINER: RANDOM WOOD, PATTERN #1217, BY SPEC FORMLINERS, INC.
- STAIN COLOR FOR CAP: 'SEAL BROWN'
- STAIN COLOR FOR VERTICAL WALLS: 'PINE'
- SEE SHEET L-303 FOR MORE INFORMATION
- STAINS TO BE BOWMANITE CHEMICAL STAINS

EXISTING HEAD WALL AESTHETIC TREATMENTS

- STAIN EXISTING EXPOSED FACES OF HEADWALL (VERTICAL AND HORIZONTAL FACES)
- STAIN COLOR FOR CAP: 'SEAL BROWN'
- STAIN COLOR FOR VERTICAL DECORATIVE WALLS: 'PINE'
- SAWCUT 1/4" JOINT 6" BELOW TOP OF WALL TO MATCH WING WALLS AND CREATE WALL "CAP" AESTHETIC.
- STAINS TO BE BOWMANITE CHEMICAL STAINS
- SEE SHEET L-303 FOR MORE INFORMATION

RAILING - SEE DETAIL 1 / SHEET 19

- NOTES:**
1. SEE STRUCTURAL SHEETS FOR STRUCTURE LAY OUT, FOOTERS, JOINT LAYOUT, AND DESIGN DETAILS.
 2. SEE SHEET L-302 FOR ADDITIONAL AESTHETIC DESIGN DETAILS.
 3. FORMLINER TO BE PATTERN #1217 'RANDOM WOOD' - BY SPEC FORMLINER (714) 429-9500.
 4. FORMLINER TO BE PLACED WITH RIBS RUNNING HORIZONTALLY.

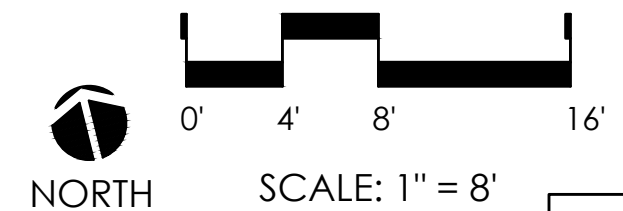

1 OUTFALL STRUCTURE AESTHETIC PLAN
L-301 PLAN

SCALE: 1/8" = 1'-0"



REV	REVISION DESCRIPTION	DATE	CHND	CHKD	APPR



CITY OF COLORADO SPRINGS
30 S. NEVADA AVE., SUITE 401
COLORADO SPRINGS, CO 80903
(719) 385-5980

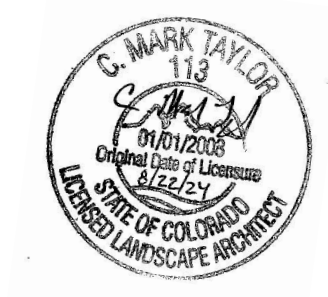

SAND CREEK DETENTION POND NO. 2
OUTFALL STRUCTURE AESTHETIC DETAILS

JOB NUMBER	65420975
DATE	AUGUST 2024
DRAWING	L-301
29	of 51

THIS AND ANY OTHER TECHNICAL DRAWING OR INSTRUMENT IS AN INSTRUMENT OF SERVICE PROVIDED BY MERRICK AND COMPANY FOR A SPECIFIC PROJECT. IT IS NOT INTENDED OR REPRESENTED TO BE SUITABLE FOR REUSE IN WHOLE OR IN PART OR FOR EXTENSION OF THE PROJECT OR FOR ANY OTHER PROJECT. REUSE OR MODIFICATION OF ANY INSTRUMENT WITHOUT THE PRIOR WRITTEN CONSENT OF MERRICK AND COMPANY SHALL BE AT THE USER'S RISK. THE USER ASSUMES ALL LIABILITY FOR ANY SUCH REUSE OR MODIFICATION.

File Location: \\projects\12105-Sand Creek Pond #2 Drawings - Technical\Construction Drawings\2106 - Sand Creek Pond #2 Architectural Details.dwg Plot Date: 8/22/2024 4:53 PM Last Saved By: MT-ALERICO

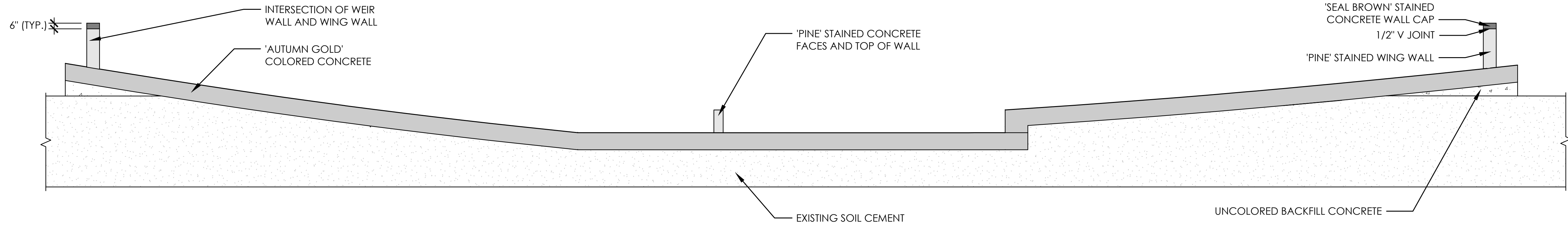

1 OUTFALL STRUCTURE - SECTION A-A
L-302 SECTION

SCALE: 3/16" = 1'-0"

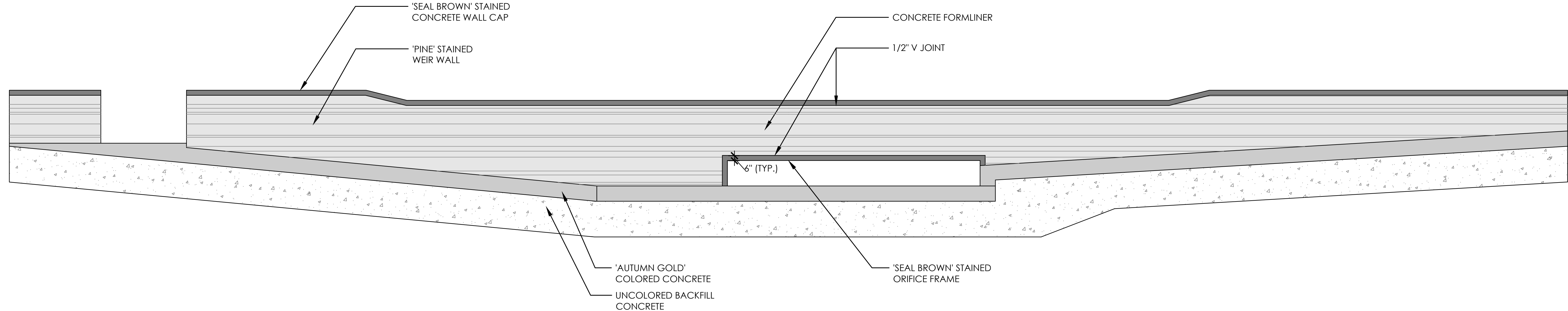

2 OUTFALL STRUCTURE WEIR WALL - SECTION / ELEVATION B-B
L-302 SECTION / ELEVATION

SCALE: 3/16" = 1'-0"

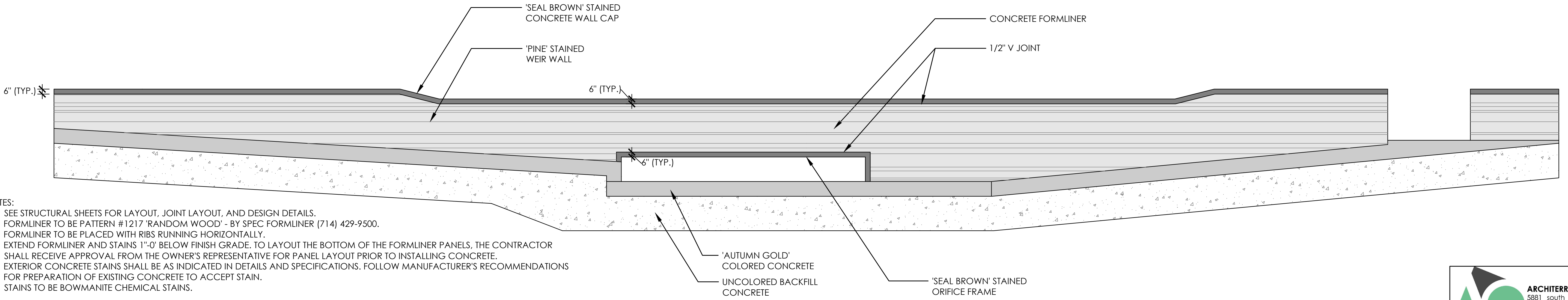

- NOTES:
1. SEE STRUCTURAL SHEETS FOR LAYOUT, JOINT LAYOUT, AND DESIGN DETAILS.
 2. FORMLINER TO BE PATTERN #1217 'RANDOM WOOD' - BY SPEC FORMLINER (714) 429-9500.
 3. FORMLINER TO BE PLACED WITH RIBS RUNNING HORIZONTALLY.
 4. EXTEND FORMLINER AND STAINS 1"-0" BELOW FINISH GRADE. TO LAYOUT THE BOTTOM OF THE FORMLINER PANELS, THE CONTRACTOR SHALL RECEIVE APPROVAL FROM THE OWNER'S REPRESENTATIVE FOR PANEL LAYOUT PRIOR TO INSTALLING CONCRETE.
 5. EXTERIOR CONCRETE STAINS SHALL BE AS INDICATED IN DETAILS AND SPECIFICATIONS. FOLLOW MANUFACTURER'S RECOMMENDATIONS FOR PREPARATION OF EXISTING CONCRETE TO ACCEPT STAIN.
 6. STAINS TO BE BOWMANITE CHEMICAL STAINS.

3 OUTFALL STRUCTURE WEIR WALL - SECTION / ELEVATION C-C
L-302 SECTION / ELEVATION

SCALE: 3/16" = 1'-0"

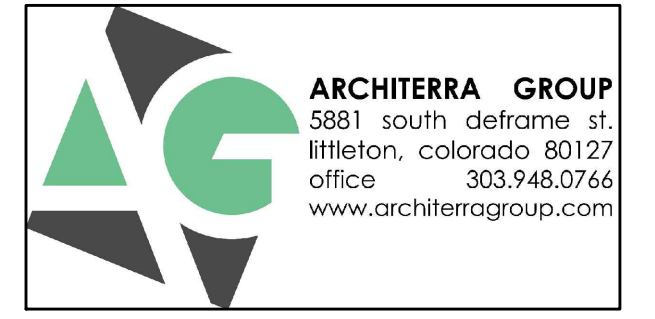

REV	REVISION DESCRIPTION	DATE	CHND	CHKD	APPR



CITY OF COLORADO SPRINGS
30 S. NEVADA AVE., SUITE 401
COLORADO SPRINGS, CO 80903
(719) 385-5980



SAND CREEK DETENTION POND NO. 2
OUTFALL STRUCTURE AESTHETIC DETAILS

JOB NUMBER	65420975
DATE	AUGUST 2024
DRAWING	L-302
30 of 51	478 of 507

THE NEW ORANGE COUNTY WATER TREATMENT PLANT IS AN INSTRUMENT OF SERVICE PROVIDED BY ARCHITERRA GROUP, INC. FOR THE PROJECT. IT IS NOT INTENDED OR REPRESENTED TO BE SUITABLE FOR USE IN WHOLE OR IN PART OR FOR EXTENSION OF THE PROJECT OR ON ANY OTHER PROJECT. REUSE OR MODIFICATION OF ANY INFORMATION NOT A FINISHED INSTRUMENT WITHOUT THE PROPER EXPRESSION OF WRITTEN CONSENT OF ARCHITERRA GROUP, INC. SHALL BE AT THE USER'S RISK. THIS DRAWING IS THE PROPERTY OF ARCHITERRA GROUP, INC. AND IS NOT TO BE REPRODUCED OR COPIED IN ANY MANNER WITHOUT THE WRITTEN CONSENT OF ARCHITERRA GROUP, INC.

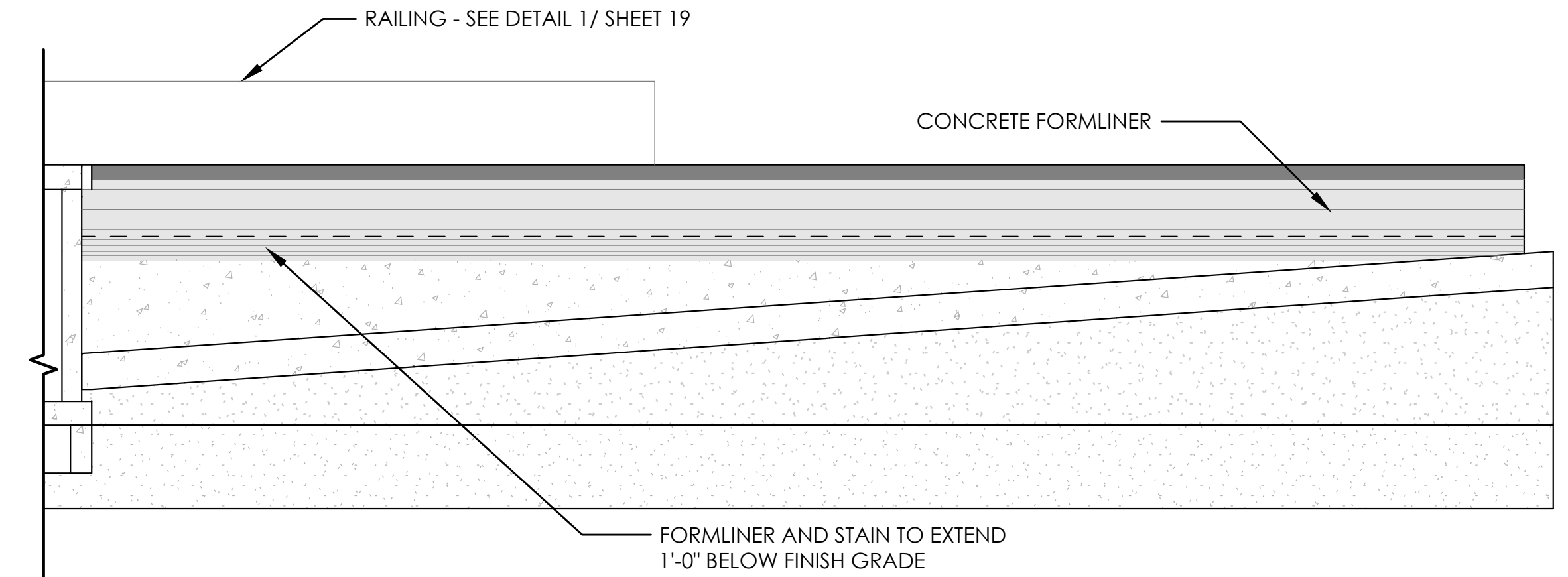
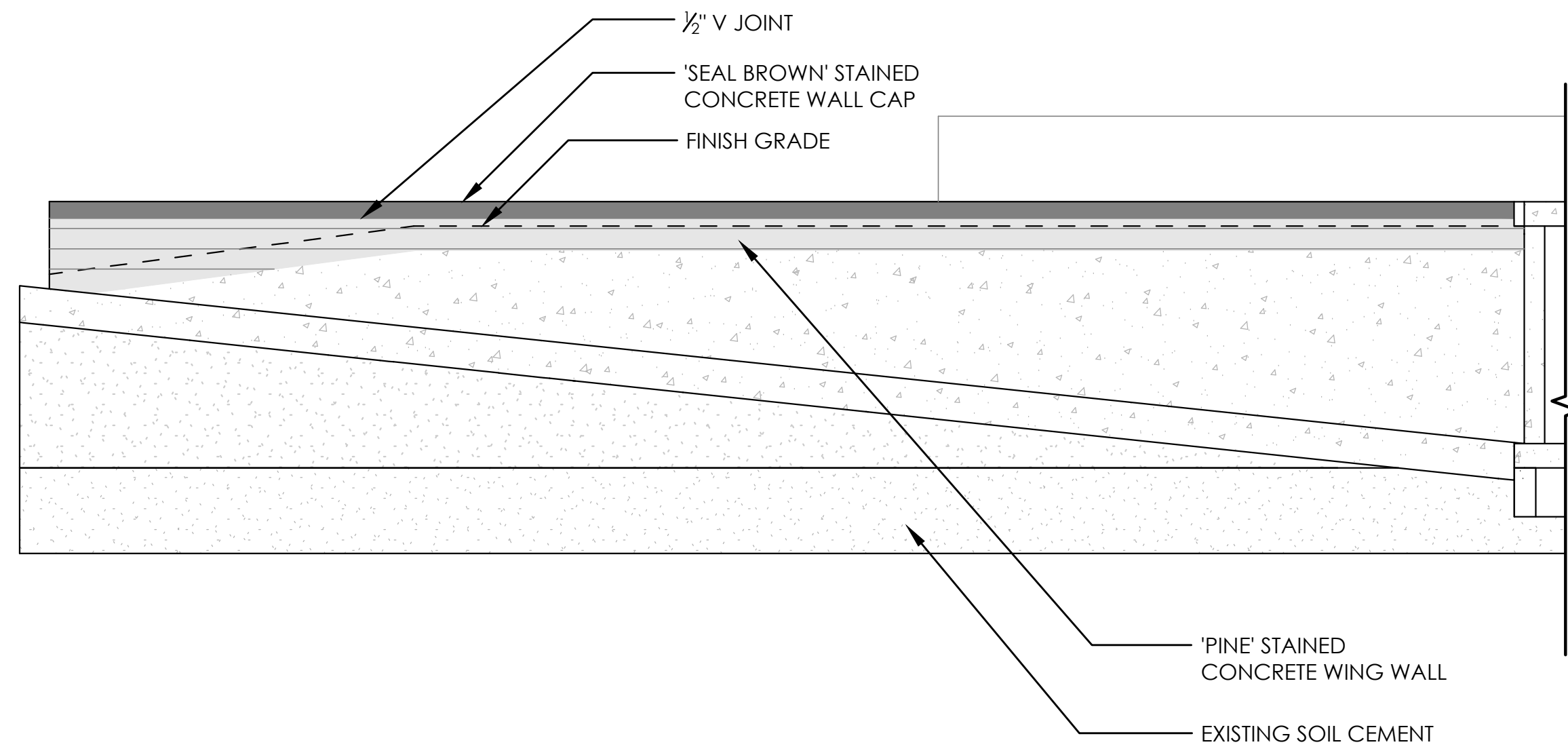

1 OUTFALL STRUCTURE WING WALLS - SECTION / ELEVATION D-D
 L-303 SECTION / ELEVATION

SCALE: 3/16" = 1'-0"

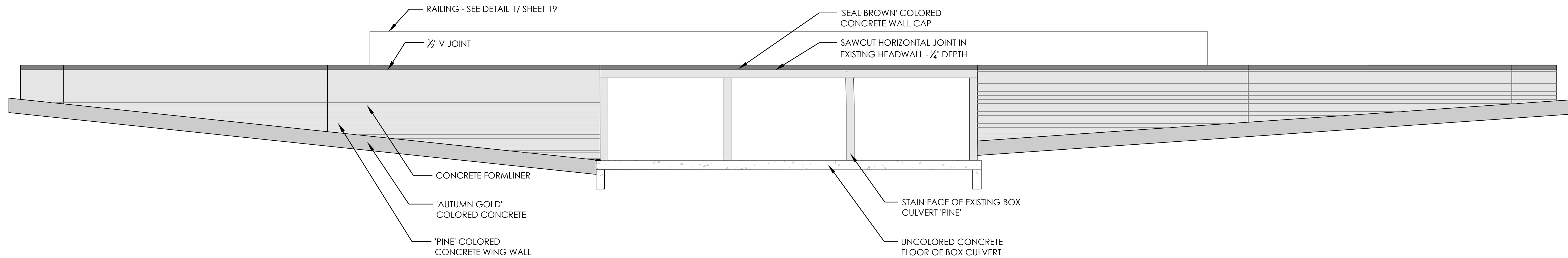

2 OUTFALL STRUCTURE WING WALLS - SECTION / ELEVATION E-E
 L-303 SECTION / ELEVATION

SCALE: 3/16" = 1'-0"

- NOTES:
- SEE STRUCTURAL SHEETS FOR LAYOUT, JOINT LAYOUT, AND DESIGN DETAILS.
 - FORMLINER TO BE PATTERN #1217 'RANDOM WOOD' - BY SPEC FORMLINER (714) 429-9500.
 - FORMLINER TO BE PLACED WITH RIBS RUNNING HORIZONTALLY.
 - EXTEND FORMLINER AND STAINS 1'-0" BELOW FINISH GRADE. TO LAYOUT THE BOTTOM OF THE FORMLINER PANELS, THE CONTRACTOR SHALL RECEIVE APPROVAL FROM THE OWNER'S REPRESENTATIVE FOR PANEL LAYOUT PRIOR TO INSTALLING CONCRETE.
 - EXTERIOR CONCRETE STAINS SHALL BE AS INDICATED IN DETAILS AND SPECIFICATIONS. FOLLOW MANUFACTURER'S RECOMMENDATIONS FOR PREPARATION OF EXISTING CONCRETE TO ACCEPT STAIN.
 - STAINS TO BE BOWMANITE CHEMICAL STAINS.



REV	REVISION DESCRIPTION	DATE	CHND	CHKD	APPR



CITY OF COLORADO SPRINGS
 30 S. NEVADA AVE., SUITE 401
 COLORADO SPRINGS, CO 80903
 (719) 385-5980

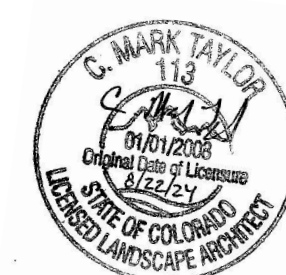

SAND CREEK DETENTION POND NO. 2
 OUTFALL STRUCTURE AESTHETIC DETAILS

JOB NUMBER	65420975
DATE	AUGUST 2024
DRAWING	L-303
31	of 51

THIS AND ALL OTHERS ARE EXISTING. ANY INFORMATION OR SERVICE PROVIDED BY MERRICK AND COMPANY, FOR A DESIGN PROJECT, IS NOT INTENDED OR REPRESENTED TO BE SUITABLE FOR REUSE IN WHOLE OR IN PART FOR ANY OTHER PROJECT OR ANY OTHER PURPOSE. REUSE OR MODIFICATION OF ANY INFORMATION OR SERVICE WITHOUT THE WRITTEN CONSENT OF MERRICK AND COMPANY SHALL BE AT THE USER'S RISK. THE USER ASSUMES ALL LIABILITY FOR SUCH REUSE AND CONSEQUENCE.

File Location: C:\projects\12105-Sand Creek Pond #2 Drawings - Technical\Construction Drawings\2106 - Sand Creek Pond #2 Architectural Details.dwg Plot Date: 8/22/2024 4:55 PM Last Saved By: M.T. ALERICO

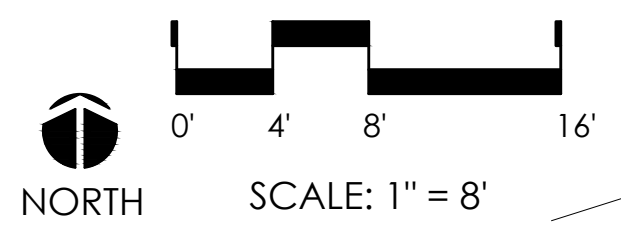
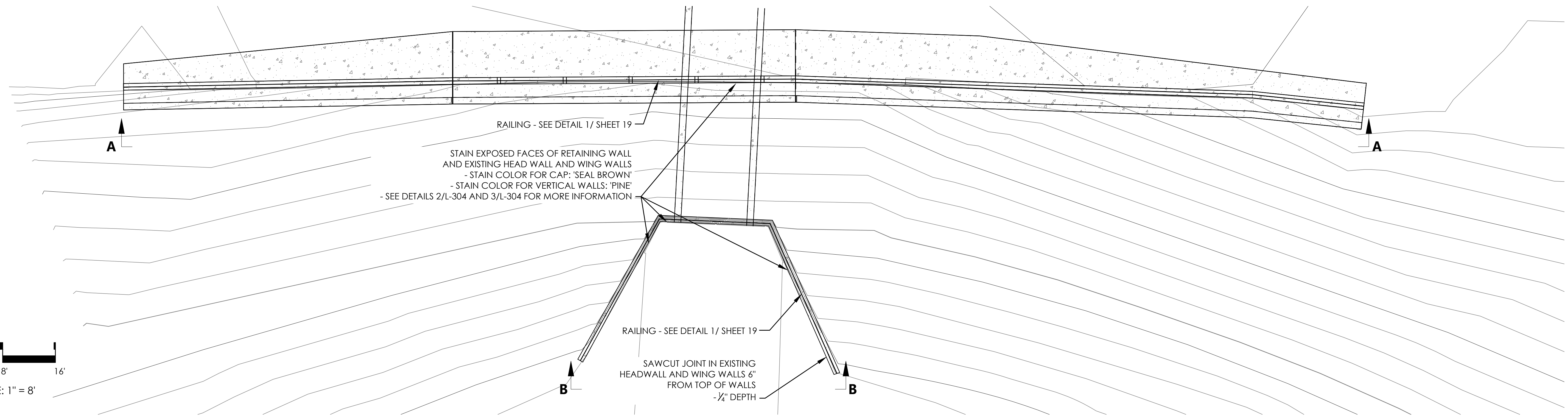

1 TUTT OUTFALL STRUCTURE AESTHETIC PLAN
L-304 PLAN

SCALE: 1/8" = 1'-0"

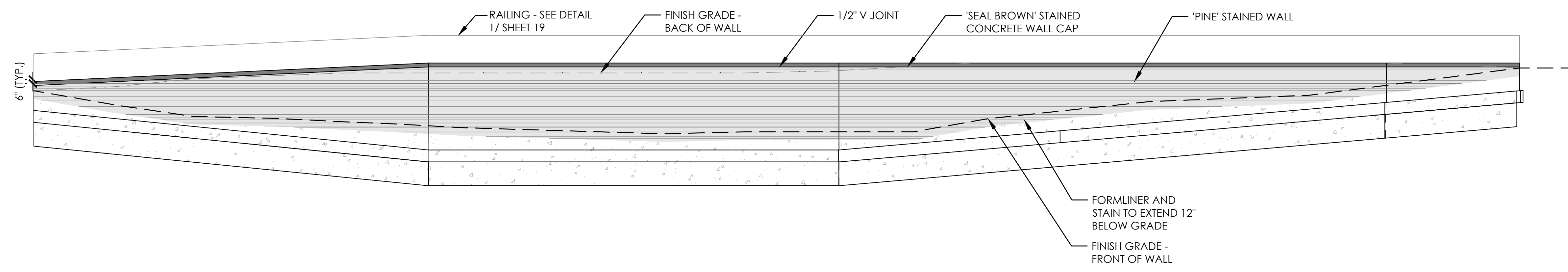

2 TUTT RETAINING WALL - SECTION / ELEVATION A-A
L-304 SECTION / ELEVATION

SCALE: 1/8" = 1'-0"

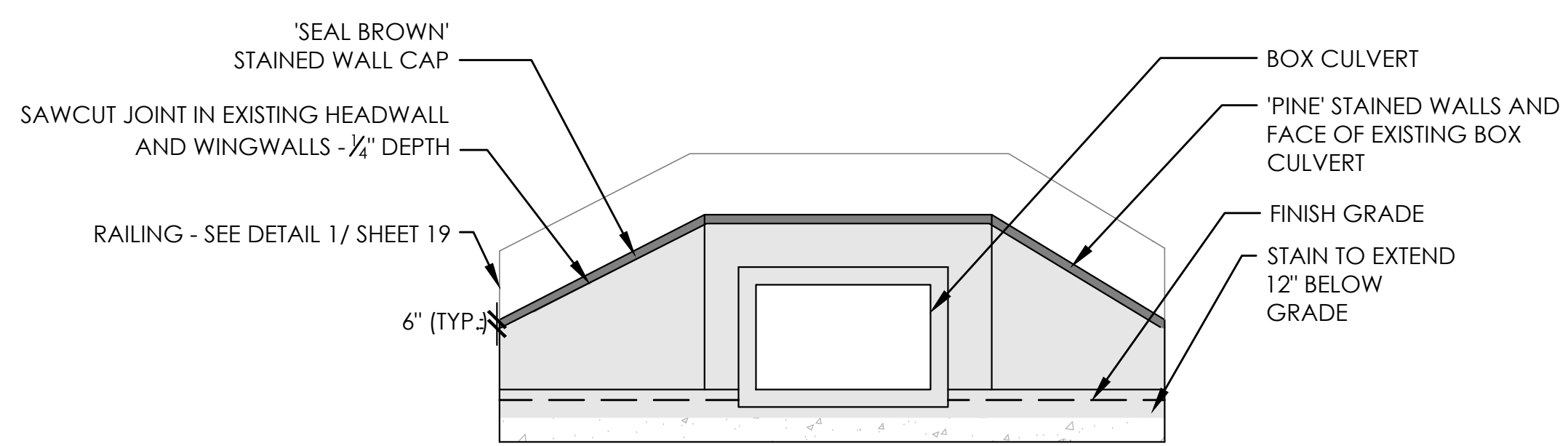

3 TUTT OUTFALL STRUCTURE - SECTION / ELEVATION B-B
L-304 SECTION / ELEVATION

SCALE: 1/8" = 1'-0"

- NOTES:
1. SEE STRUCTURAL SHEETS FOR LAYOUT, JOINT LAYOUT, AND DESIGN DETAILS.
 2. FORMLINER TO BE PATTERN #1217 'RANDOM WOOD' - BY SPEC FORMLINER (714) 429-9500.
 3. FORMLINER TO BE PLACED WITH RIBS RUNNING HORIZONTALLY.
 4. EXTEND FORMLINER AND STAINS 1'-0" BELOW FINISH GRADE. TO LAYOUT THE BOTTOM OF THE FORMLINER PANELS, THE CONTRACTOR SHALL RECEIVE APPROVAL FROM THE OWNER'S REPRESENTATIVE FOR PANEL LAYOUT PRIOR TO INSTALLING CONCRETE.
 5. EXTERIOR CONCRETE STAINS SHALL BE AS INDICATED IN DETAILS AND SPECIFICATIONS. FOLLOW MANUFACTURER'S RECOMMENDATIONS FOR PREPARATION OF EXISTING CONCRETE TO ACCEPT STAIN.
 6. STAINS TO BE BOWMANITE CHEMICAL STAINS.



REV	REVISION DESCRIPTION	DATE	CHND	CHKD	APPR



CITY OF COLORADO SPRINGS
30 S. NEVADA AVE., SUITE 401
COLORADO SPRINGS, CO 80903
(719) 385-5980



SAND CREEK DETENTION POND NO. 2
TUTT OUTFALL AND RETAINING WALL
AESTHETIC DETAILS

JOB NUMBER	65420975
DATE	AUGUST 2024
DRAWING	L-304
32	of 51



STRUCTURAL DRAWING LIST

SHEET No.	DRAWING No.	TITLE
33	S-100	LEGEND, ABBREVIATIONS, AND GENERAL NOTES SHEET 1
34	S-101	LEGEND, ABBREVIATIONS, AND GENERAL NOTES SHEET 2
35	S-102	POND 2 OUTLET ISOMETRIC VIEW
36	S-103	POND 2 OUTLET OUTLINE PLAN
37	S-104	POND 2 OUTLET OUTLINE SECTIONS
38	S-105	POND 2 OUTLET REINFORCEMENT PLAN
39	S-106	POND 2 OUTLET REINFORCEMENT SECTIONS
40	S-107	POND 2 OUTLET REINFORCEMENT SECTIONS
41	S-108	POND 2 OUTLET REINFORCEMENT SECTIONS
42	S-109	POND 2 OUTLET DOWEL ANCHOR PLAN AND DETAILS
43	S-110	POND 2 OUTLET UNDER DRAIN PLAN AND DETAILS
44	S-111	POND 2 OUTLET CONCRETE STANDARD DETAILS
45	S-112	TUTT WALL ISOMETRIC
46	S-113	TUTT WALL OUTLINE PLAN AND ELEVATION
47	S-114	TUTT WALL REINFORCEMENT PLAN AND SECTION
48	S-115	TUTT WALL REINFORCEMENT PLAN AND SECTION
49	S-116	TUTT WALL REINFORCEMENT PLAN AND SECTION
50	S-117	TUTT WALL REINFORCEMENT PLAN AND SECTIONS
51	S-118	POND OUTLET 2 & TUTT RETAINING WALL STEEL HANDRAIL DETAILS

ABBREVIATIONS/LEGEND

NOT ALL ABBREVIATIONS MAY APPLY TO THIS PROJECT

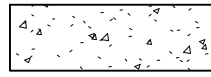
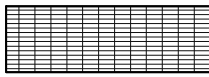
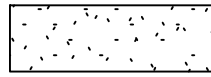
ADDL	ADDITIONAL	GW	GROUND WATER
CL	CENTERLINE	HORIZ	HORIZONTAL
CJ	CONSTRUCTION JOINT	IE	INVERT ELEVATION
CONT JT	CONTRACTION JOINT	IF	INSIDE FACE
CTRL JT	CONTROL JOINT	LLV	LONG LEG VERTICAL
CLR	CLEAR	MAX	MAXIMUM
CMP	CORRUGATED METAL PIPE	MIN	MINIMUM
CONC	CONCRETE	N	NORTH
CONT	CONTINUED/CONTINUOUS	NF	NEAR FACE
DET	DETAIL	OC	ON CENTER
DIA	DIAMETER	OF	OUTSIDE FACE
DWGS	DRAWINGS	OPNG	OPENING
DWLS	DOWELS	OPP	OPPOSITE
EA	EACH	PL	PLATE
EF	EACH FACE	REINF	REINFORCEMENT
EL	ELEVATION	SECT	SECTION
EMB/EMBED	EMBEDDED	SS/SST	STAINLESS STEEL
EQ SP	EQUAL SPACE	STL	STEEL
EW	EACH WAY	T&B	TOP AND BOTTOM
EXIST	EXISTING	THK	THICK
EXP	EXPANSION	TYP	TYPICAL
FF	FAR FACE	UNO	UNLESS NOTED OTHERWISE
GALV	GALVANIZED	VERT	VERTICAL
GR	GRADE	W/	WITH
		WS	WATER SURFACE

	COMPACTED STRUCTURAL FILL		CONCRETE
	GRATING		BACKFILL CONCRETE
	NATIVE FILL		EXISTING SOIL CEMENT

GENERAL NOTES

- ALL MATERIALS, WORKMANSHIP, AND CONSTRUCTION OF PUBLIC IMPROVEMENTS SHALL MEET OR EXCEED THE STANDARDS AND SPECIFICATIONS ADOPTED BY THE CITY OF COLORADO SPRINGS. ALL PUBLIC IMPROVEMENTS SHALL BE INSPECTED AND APPROVED BY THE CITY.
- ALL WORK SHALL CONFORM TO THE INTERNATIONAL BUILDING CODE 2018 EDITION AS AMENDED BY CITY OF COLORADO SPRINGS.
- THE CONTRACTOR IS SPECIFICALLY CAUTIONED THAT THE LOCATION AND/OR ELEVATION OF EXISTING UTILITIES, AS SHOWN ON THESE PLANS, IS BASED UPON RECORDS OF VARIOUS UTILITY COMPANIES AND WHERE POSSIBLE, MEASUREMENTS TAKEN IN THE FIELD. THE INFORMATION IS NOT TO BE RELIED UPON AS BEING EXACT OR COMPLETE. THE SUBSURFACE UTILITY ENGINEERING FOR THE PROJECT IS QUALITY LEVEL D. CALL THE UTILITY NOTIFICATION CENTER OF COLORADO AT 1-800-922-1987 AT LEAST 48 HOURS BEFORE STRIPPING, OR EXCAVATING. PRIOR TO CONSTRUCTION, THE CONTRACTOR SHALL VERIFY PERTINENT LOCATIONS AND ELEVATIONS. IT SHALL BE THE RESPONSIBILITY OF THE CONTRACTOR TO RELOCATE ALL EXISTING UTILITIES THAT CONFLICT WITH THE PROPOSED IMPROVEMENTS SHOWN ON THESE PLANS.
- THE CONTRACTOR SHALL COORDINATE AND COOPERATE WITH THE CITY, AND ALL UTILITY COMPANIES INVOLVED, WITH REGARD TO RELOCATIONS OR ADJUSTMENTS OF EXISTING UTILITIES DURING CONSTRUCTION, AND TO ASSURE THAT THE WORK IS COMPLETED IN A TIMELY FASHION AND WITH A MINIMUM DISRUPTION OR SERVICE. THE CONTRACTOR SHALL BE RESPONSIBLE FOR CONTACTING ALL PARTIES AFFECTED BY ANY DISRUPTION OF UTILITY SERVICE.
- THE CONTRACTOR SHALL OBTAIN ALL NECESSARY PERMITS FROM REGULATORY AUTHORITIES NECESSARY TO PERFORM THE PROPOSED WORK A MINIMUM OF 48 HOURS BEFORE THE START OF CONSTRUCTION. A PERMIT FOR WORK WITHIN THE COLORADO DEPARTMENT OF TRANSPORTATION'S (CDOT'S) RIGHT OF WAY WILL BE REQUIRED. THE CONTRACTOR SHALL APPLY FOR THE PERMIT TO CDOT NO MORE THAN 3 DAYS AFTER GIVEN NOTICE TO PROCEED.
- THE CONTRACTOR IS RESPONSIBLE FOR SURVEYS TO LAYOUT AND CONSTRUCT THE WORK, AND FOR QUANTITY DETERMINATIONS FOR UNIT PRICE ITEMS.
- THE CONTRACTOR SHALL NOT SCALE DRAWINGS FOR CONSTRUCTION PURPOSES. ANY MISSING DIMENSIONS OR DISCREPANCIES IN THE DRAWINGS, SPECIFICATIONS, OR PHYSICAL FEATURES SHALL BE BROUGHT TO THE ATTENTION OF THE ENGINEER FOR RESOLUTION. IF THE CONTRACTOR PROCEEDS PRIOR TO OBTAINING THE ENGINEERS RESOLUTION, CONTRACTOR DOES SO AT THEIR OWN RISK.
- THE CONTRACTOR SHALL MAINTAIN A SET OF THE CONSTRUCTION DRAWINGS AND SPECIFICATIONS ON SITE AT ALL TIMES. ONE SET OF THE CONSTRUCTION DRAWINGS SHALL BE MAINTAINED SOLELY TO DOCUMENT ANY CHANGES IN THE WORK AS A RESULT OF CHANGE ORDERS OR FIELD CONDITIONS THAT MAY REQUIRE ALTERNATIVE CONSTRUCTION DETAILS. ALL SUCH CHANGES SHALL BE MARKED ON A FULL SIZE RECORD SET OF DRAWINGS IN PERMANENT INK.
- CONSTRUCTION SAFETY IS THE SOLE RESPONSIBILITY OF THE CONTRACTOR. THE ENGINEER IS NOT RESPONSIBLE FOR SAFETY IN, ON, OR ABOUT THE PROJECT SITE, NOR FOR COMPLIANCE BY THE APPROPRIATE PARTY WITH ANY REGULATIONS RELATING THERETO.
- EXCAVATIONS SHALL BE SHORED AS REQUIRED TO PREVENT SUBSIDENCE OR DAMAGE TO ADJACENT EXISTING STRUCTURES, STREETS, UTILITIES, ETC.
- CONSTRUCTION SHORING AND BRACING OF FORMWORK SHALL BE IN ACCORDANCE WITH ACI 301 "SPECIFICATIONS FOR STRUCTURAL CONCRETE FOR BUILDINGS" AND ACI 347 "RECOMMENDED PRACTICE FOR CONCRETE FORMWORK".
- THE STRUCTURES SHOWN ON THE DRAWINGS HAVE BEEN DESIGNED FOR STABILITY UNDER FINAL CONDITIONS ONLY. THESE PLANS DO NOT INCLUDE THE NECESSARY COMPONENTS OR EQUIPMENT FOR THE STRUCTURES DURING CONSTRUCTION. THE CONTRACTOR IS RESPONSIBLE FOR ALL WORK RELATING TO CONSTRUCTION ERECTION METHODS, BRACING, SHORING, RIGGING, GUYS, SCAFFOLDING, FORMWORK, AND OTHER WORK AIDS REQUIRED TO SAFELY PERFORM THE WORK SHOWN.
- HEAVY COMPACTION EQUIPMENT SHALL NOT BE USED WITHIN 5'-0" OF WALLS. USE HAND GUIDED COMPACTION EQUIPMENT FOR THESE AREAS.
- OBSERVATIONS OF THE WORK IN PROGRESS AND ON-SITE VISITS BY THE ENGINEER OR OWNER ARE NOT TO BE CONSTRUED AS ACCEPTANCE OR WARRANTIES OF THE CONTRACTOR'S CONTRACTUAL OBLIGATIONS.
- CONTRACTOR SHALL SUBMIT SHOP DRAWINGS FOR CONCRETE MIXTURE DESIGN, CONCRETE REINFORCEMENT, HANDRAIL, AND STRUCTURAL AND MISCELLANEOUS STEEL PRIOR TO FABRICATION FOR ENGINEER REVIEW.
- SPECIAL INSPECTION (OWNER FURNISHED) IS REQUIRED IN ACCORDANCE WITH IBC CHAPTER 17 INCLUDING THE FOLLOWING PORTIONS OF THE WORK:
 - CONCRETE
 - REINFORCING STEEL
 - CAST-IN-PLACE ANCHOR BOLTS AND EMBEDS
- ALL FOUNDATION SURFACES SHALL BE INSPECTED BY THE GEOTECHNICAL ENGINEER PRIOR TO PLACEMENT OF GRANULAR FILL AND REINFORCING STEEL. NOTIFY ENGINEER AT LEAST TWO DAYS IN ADVANCE.
- NOTIFY THE ENGINEER AT LEAST 48 HOURS IN ADVANCE OF ANY CONCRETE PLACEMENTS.
- CONCRETE TESTS FOR CONCRETE DELIVERED TO THE SITE AND SOIL COMPACTION TESTING ARE THE RESPONSIBILITY OF THE CONTRACTOR. THE ENGINEER RESERVES THE RIGHT TO CONDUCT ITS OWN TESTS AS HE MAY DEEM NECESSARY.
- SEE ARCHITECTURAL PLANS FOR AESTHETIC TREATMENT INCLUDING COLORED CONCRETE, FORMLINER, AND CONCRETE FINISHES.
- SEE CIVIL PLANS FOR LOCATION OF ALL STRUCTURES.
- SEE 12/06 KIOWA ENGINEERING CORPORATION DRAWING: SAND CREEK DETENTION BASIN NO. 2, BOX CULVERT DETAILS, SHEET 13A, FOR EXISTING CONDITIONS.

REV	REVISION DESCRIPTION	DATE	CHND	CHKD	APPR



CITY OF COLORADO SPRINGS
30 S. NEVADA AVE., SUITE 401
COLORADO SPRINGS, CO 80903
(719) 385-5980

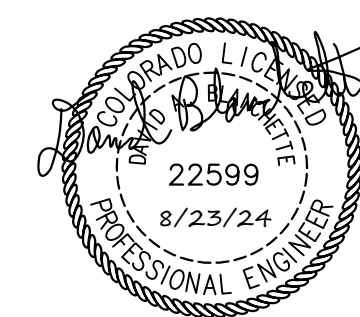

SAND CREEK DETENTION POND NO. 2

POND OUTLET STRUCTURE
LEGEND, ABBREVIATIONS, AND GENERAL NOTES SHEET 1

JOB NUMBER	65420975
DATE	8/23/24
DRAWING NO.	S-100
SHEET	33 of 51



CONCRETE NOTES

- ALL CONCRETE IS DESIGNED IN ACCORDANCE WITH AMERICAN CONCRETE INSTITUTE, ACI 350-20 OR ACI 318-14 AND SHALL BE CONSTRUCTED IN ACCORDANCE WITH PROJECT SPECIFICATIONS.
- CONCRETE SHALL HAVE A MINIMUM 28 DAY COMPRESSIVE STRENGTH OF 4500 PSI UNLESS NOTED OTHERWISE.
- CONCRETE WORK SHALL CONFORM TO ACI 301.
- REINFORCEMENT STEEL SHALL BE DEFORMED BARS CONFORMING IN QUALITY TO THE REQUIREMENTS OF ASTM A-615, "SPECIFICATIONS FOR DEFORMED AND PLAIN CARBON STEEL BARS FOR CONCRETE REINFORCEMENT", GRADE 60.
- ALL DETAILING, FABRICATION AND PLACING OF REINFORCING BARS, UNLESS OTHERWISE INDICATED, SHALL BE IN ACCORDANCE WITH ACI-315, "MANUAL OF STANDARD PRACTICE FOR DETAILING REINFORCED CONCRETE STRUCTURES", LATEST EDITION.
- CONSTRUCTION TOLERANCES SHALL BE IN ACCORDANCE WITH ACI 117.
- METAL CLIPS OR SUPPORTS SHALL NOT BE PLACED IN CONTACT WITH THE FORMS OR THE SUBGRADE. CONCRETE BLOCKS (OR DOBIES) SUPPORTING BARS ON SUBGRADE SHALL BE IN SUFFICIENT NUMBERS TO SUPPORT THE BARS WITHOUT SETTLEMENT, BUT IN NO CASE SHALL SUCH SUPPORT BE CONTINUOUS.
- REINFORCING BARS AND ACCESSORIES SHALL NOT BE IN CONTACT WITH THE FORMS, PIPE, PIPE FLANGE OR METAL PARTS EMBEDDED IN CONCRETE, A MINIMUM OF 2 INCHES CLEARANCE SHALL BE PROVIDED AT ALL TIMES.
- UNLESS OTHERWISE SHOWN ON THE DRAWINGS CONCRETE COVER FOR REINFORCING BARS SHALL BE AS FOLLOWS:
 - FOR CONCRETE PLACED AGAINST EARTH 3"
 - FOR CONCRETE FORMED BUT EXPOSED TO EARTH, WEATHER, OR FLOWING WATER 2"
- UNLESS OTHERWISE NOTED, WALLS AND SLABS SHOWN WITH A SINGLE LAYER OF REINFORCEMENT SHALL HAVE THAT REINFORCEMENT CENTERED.
- PLACING OF CONCRETE SHALL CONFORM TO ACI 304R. HOT WEATHER CONCRETE SHALL BE PLACED PER ACI 305R. COLD WEATHER CONCRETE SHALL BE PLACED PER ACI 306R.
- ALL DIMENSIONS TO A JOINT ARE TO THE CENTERLINE OF THE JOINT.
- DIMENSIONS NOT SHOWN ARE THE SAME AS DIMENSIONS FOR IDENTICAL DETAILS SHOWN ELSEWHERE.
- BEFORE PLACING CONCRETE ON GRADE, CARE SHALL BE TAKEN THAT ALL BURIED MATERIAL BELOW GRADE IS IN PLACE.
- PIPE SLEEVES AND EMBEDDED PIPING 12" IN DIAMETER AND LARGER ARE ALWAYS SHOWN ON THE CONCRETE OUTLINE DRAWINGS. SMALLER DIAMETER PIPE SLEEVES OR PIPING MAY OR MAY NOT BE SHOWN ON THE CONCRETE OUTLINE DRAWINGS.
- CHAMFER EDGES OF PERMANENTLY EXPOSED CONCRETE SURFACES WITH A 45 DEGREE BEVEL, 3/4"x3/4".
- DRAWINGS ARE NOT TO BE SCALED FOR ESTIMATING OR ANY OTHER PURPOSE.
- ALL REINFORCEMENT BENDS AND LAPS, UNLESS OTHERWISE NOTED, SHALL SATISFY THE FOLLOWING MINIMUM REQUIREMENT:

DETAIL OF REINFORCEMENT - LAP LENGTHS

BAR SIZE	#4	#5	#6	#7	#8	#9	#10	#11	
CONCRETE DESIGN STRENGTH	4500 PSI								
GR 60	TOP BAR OTHER BAR	2'-6" 1'-11"	3'-2" 2'-5"	3'-9" 2'-11"	5'-6" 4'-3"	6'-4" 4'-10"	7'-1" 5'-6"	8'-0" 6'-2"	8'-11" 6'-10"

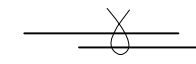
* TOP BARS SHALL BE DEFINED AS ANY HORIZONTAL BARS PLACED SUCH THAT MORE THAN 12" FRESH CONCRETE IS CAST IN THE MEMBER BELOW THE BAR, IN ANY SINGLE PLACEMENT. HORIZONTAL WALL BARS ARE CONSIDERED TOP BARS.

- SPLICES ARE TO BE MADE SO THAT THE GIVEN DISTANCES TO FACE OF CONCRETE WILL BE MAINTAINED.
- DIMENSIONS ARE TO THE CENTERLINES OF THE BARS UNLESS SHOWN OTHERWISE.
- REINFORCEMENT PARALLELING CONSTRUCTION JOINTS SHALL HAVE A MINIMUM OF 2" CLEAR COVER.
- REINFORCEMENT AT SMALL OPENINGS (MAX 1'-6") IN WALLS AND SLABS MAY BE SPREAD APART NOT MORE THAN 1 1/2 TIMES THE BAR SPACING.
- REINFORCEMENT MAY BE ADJUSTED Laterally TO MAINTAIN A CLEAR DISTANCE OF AT LEAST 1" BETWEEN THE REINFORCEMENT AND WATERSTOPS, ANCHOR BOLTS, FORM TIES, CONDUITS, AND OTHER EMBEDDED MATERIAL. IN HEAVILY REINFORCED AREAS RELOCATION OF THE EMBEDDED MATERIAL MUST BE CONSIDERED.
- IN NO CASE SHOULD BARS BE FIELD BENT TO GREATER THAN 6 TO 1 SLOPE.
- BARS SHOWN WITH BENDS NOT DIMENSIONED SHALL BE ASSUMED TO END WITH A STANDARD HOOK.
- THE  SYMBOL DESIGNATES THE BAR CALLOUTS ARE THE SAME SIZE AND SPACING.
- REINFORCEMENT PARALLEL TO ANCHOR BOLTS OR OTHER EMBEDDED MATERIAL SHALL BE PLACED TO MAINTAIN A CLEAR DISTANCE OF AT LEAST 1-1/3 TIMES THE MAXIMUM SIZE AGGREGATE.
- THE FIRST AND LAST BARS IN WALLS AND SLABS, STIRRUPS IN BEAMS, AND TIES IN COLUMNS ARE TO START AND END AT A MAXIMUM OF ONE HALF OF THE ADJACENT BAR SPACING.
- BARS SHOWN THUS  #8@12, INDICATE A GROUP OF THE SAME SIZE BARS EQUALLY SPACED.
- BACKFILL CONCRETE SHALL HAVE A MINIMUM 28 DAY COMPRESSIVE STRENGTH OF 2500 PSI.

STRUCTURAL STEEL NOTES

- ALL STRUCTURAL AND MISCELLANEOUS STEEL SHALL BE DESIGNED, FABRICATED AND ERECTED IN ACCORDANCE WITH THE LATEST CODES AND SPECIFICATIONS OF THE AMERICAN INSTITUTE OF STEEL CONSTRUCTION (AISC) AND IN ACCORDANCE WITH THESE DRAWINGS.
- ALL BARS, PLATES, AND ANGLE SHAPES SHALL BE OF STEEL MEETING ASTM A36 SPECIFICATIONS UNLESS NOTED OTHERWISE. W STRUCTURAL SHAPES SHALL CONFORM TO ASTM A992.
- ALL WELDS SHALL BE PERFORMED BY AWS CERTIFIED WELDERS AND SHALL CONFORM TO AWS D1.1 LATEST EDITION. ALL BUTT WELDS ARE FULL PENETRATION UNLESS INDICATED OTHERWISE. WELD FILLER METAL SHALL BE AWS A5.1 OR A5.5 E70 XX SERIES ELECTRODES.
- ALL WELDS FOUND DEFECTIVE SHALL BE REPAIRED AND/OR REPLACED AND RETESTED FOR ADEQUACY AT THE CONTRACTOR'S EXPENSE.
- AT ALL FIELD WELDS AT EMBED PLATES AND ANGLES, LOW HEAT AND INTERMITTENT WELDS SHALL BE UTILIZED TO AVOID SPALLING OR CRACKING THE EXISTING CONCRETE.
- ALL MATERIAL SHALL BE FABRICATED STRAIGHT AND TRUE AND FREE FROM ALL TWISTS AND WARPS.
- HANDRAIL SHALL BE ASTM A500 GRADE B.
- ANCHOR BOLTS SHALL BE SS AND SHALL CONFORM TO ASTM A240 TYPE 316 SS.
- ALL EXPOSED STEEL SHALL BE ELECTROSTATIC COATED.
- BOLTS INDICATED AS ANCHOR BOLTS SHALL CONFORM TO ASTM A307 FOR CARBON STEEL, A193 FOR STAINLESS STEEL, AND A307 WITH A153 ZINC COATING FOR GALVANIZED STEEL EXCEPT WHERE SPECIFICALLY INDICATED OTHERWISE. ALL JOINT CONTACT SURFACES SHALL BE CLEAN AND FREE FROM OIL, DIRT AND PAINT.
- CONNECTIONS NOT DETAILED SHALL BE BY THE CONTRACTOR IN ACCORDANCE WITH THE SPECIFICATION OR AS DIRECTED BY THE ENGINEER.

DESIGN CRITERIA

- APPLICABLE CODES AND STANDARDS

2021 INTERNATIONAL BUILDING CODE WITH LOCAL BUILDING CODE AMENDMENTS.

ACI 318-14 AND ACI 350-20

- LOADS

WIND LOADS

V_{ULT}.....130 MPH
EXPOSURE CATEGORY.....C
IMPORTANCE FACTOR.....IW = 1.0

SEISMIC LOADS

IMPORTANCE FACTOR.....IE = 1.0
SITE CLASS.....D
SPECTRAL RESPONSE COEFFICIENTS.....S₀₅ = 0.185 g
S₀₁ = 0.059 g

SEISMIC DESIGN CATEGORY.....A

- GEOTECHNICAL

NET ALLOWABLE BEARING PRESSURE FOOTINGS.....3000 PSF

FOUNDATION RECOMMENDATIONS ARE FROM THE REPORT " GEOTECHNICAL EVALUATION REPORT BY VIVID ENGINEERING GROUP, PROPOSED SAND CREEK POND NO. 2 IMPROVEMENTS, VICINITY OF BARNES ROAD AND TUTT BOULEVARD, COLORADO SPRINGS, CO, VIVID PROJECT NO. D21-2-389, REVISION 1."

DESIGN LOADS:

VERTICAL EARTH LOAD = 130 LBS/FT³

ACTIVE EARTH PRESSURE = 83 LBS/FT³

AT-REST EARTH PRESSURE = 94 LBS/FT³

PASSIVE STRUCTURAL FILL = 188 LBS/FT³

PASSIVE WEATHERED BEDROCK = 400 LBS/FT³

PASSIVE FORMATIONAL BEDROCK = 500 LBS/FT³

- FROST DEPTH = 2'-6"

INSPECTION NOTES

SPECIAL INSPECTIONS SHALL BE CARRIED OUT PER ALL THE REQUIREMENTS IN CHAPTER 17 OF THE 2021 INTERNATIONAL BUILDING CODE. THE OWNER IS RESPONSIBLE FOR RETAINING AN INDEPENDENT INSPECTION AGENCY TO CONDUCT THESE INSPECTIONS. ALL SPECIAL INSPECTORS MUST SUBMIT FINAL REPORTS. THE CONTRACTOR IS RESPONSIBLE FOR PROVIDING THE SPECIAL INSPECTION AGENCY WITH AN UPDATED SCHEDULE SO A PROPER COORDINATION OF WORK CAN OCCUR. SEE IBC CHAPTER 17 FOR ADDITIONAL INFORMATION ON THE FOLLOWING REQUIREMENTS.

- FOUNDATIONS

- VISUAL EXAMINATION AND APPROVAL OF ALL FOUNDATION EXCAVATIONS AND MATERIALS BELOW SHALLOW FOUNDATIONS.
- VISUAL EXAMINATION AND TESTING OF ALL COMPACTED FILL MATERIALS.

- CONCRETE

- TEST CYLINDERS FOR CONCRETE OVER 2,500 PSI.

- REINFORCING

- MILL REPORTS AND IDENTIFICATION OF REINFORCING
- PLACEMENT OF REINFORCING
- CAST IN PLACE CONCRETE ANCHORS
- POST INSTALLED CONCRETE ANCHORS

- WELDING

- ALL STRUCTURAL FIELD WELDING

- BOLTING

- ALL HIGH STRENGTH STRUCTURAL STEEL BOLTING

- STRUCTURAL STEEL

- MILL REPORTS AND IDENTIFICATION OF STEEL

- STRUCTURAL OBSERVATIONS

IN ADDITION TO SPECIAL INSPECTIONS THE STRUCTURAL ENGINEER OF RECORD SHALL BE NOTIFIED SO PERIODIC STRUCTURAL OBSERVATIONS CAN BE CONDUCTED FOR THE FOLLOWING ELEMENTS. THIS NOTIFICATION SHALL BE MADE AT LEAST 48 HRS IN ADVANCE OF THE REQUIRED STRUCTURAL OBSERVATION.

- REINFORCING STEEL
- STRUCTURAL STEEL

DRAINAGE PIPE

- DRAINAGE PIPE SHALL BE 4" DIAMETER PVC SCHEDULE 40 PLASTIC PIPE.
- DRAINAGE PIPE SHALL BE INSTALLED WITH INTERGRAL BELL AND SPIGOT JOINTS. PROVISIONS SHALL BE MADE FOR CONTRACTION AND EXPANSION AT EACH JOINT WITH A RUBBER RING.
- 4 INCH SLOTTED PIPE SHALL HAVE OPEN SLOTS 0.125" WIDE, THAT ARE 1.25" LONG IN 4 ROWS SPREAD EVENLY AROUND THE PIPE CIRCUMFERENCE. SPACING OF ROWS SHALL BE 2" O.C. SLOTS SHALL BE SHOP CUT.
- DRAIN GRAVEL SHALL CONFORM TO ASTM C33 QUALITY AND HAVE A No. 57 GRADATION.

REV	REVISION DESCRIPTION	DATE	CHND	CHKD	APPR



CITY OF COLORADO SPRINGS
30 S. NEVADA AVE., SUITE 401
COLORADO SPRINGS, CO 80903
(719) 385-5980

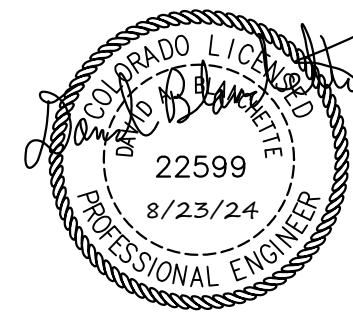

SAND CREEK DETENTION POND NO. 2

POND OUTLET STRUCTURE
LEGEND, ABBREVIATIONS, AND GENERAL NOTES SHEET 2

JOB NUMBER	65420975
DATE	8/23/24
DRAWING NO.	S-101
SHEET	34 of 51

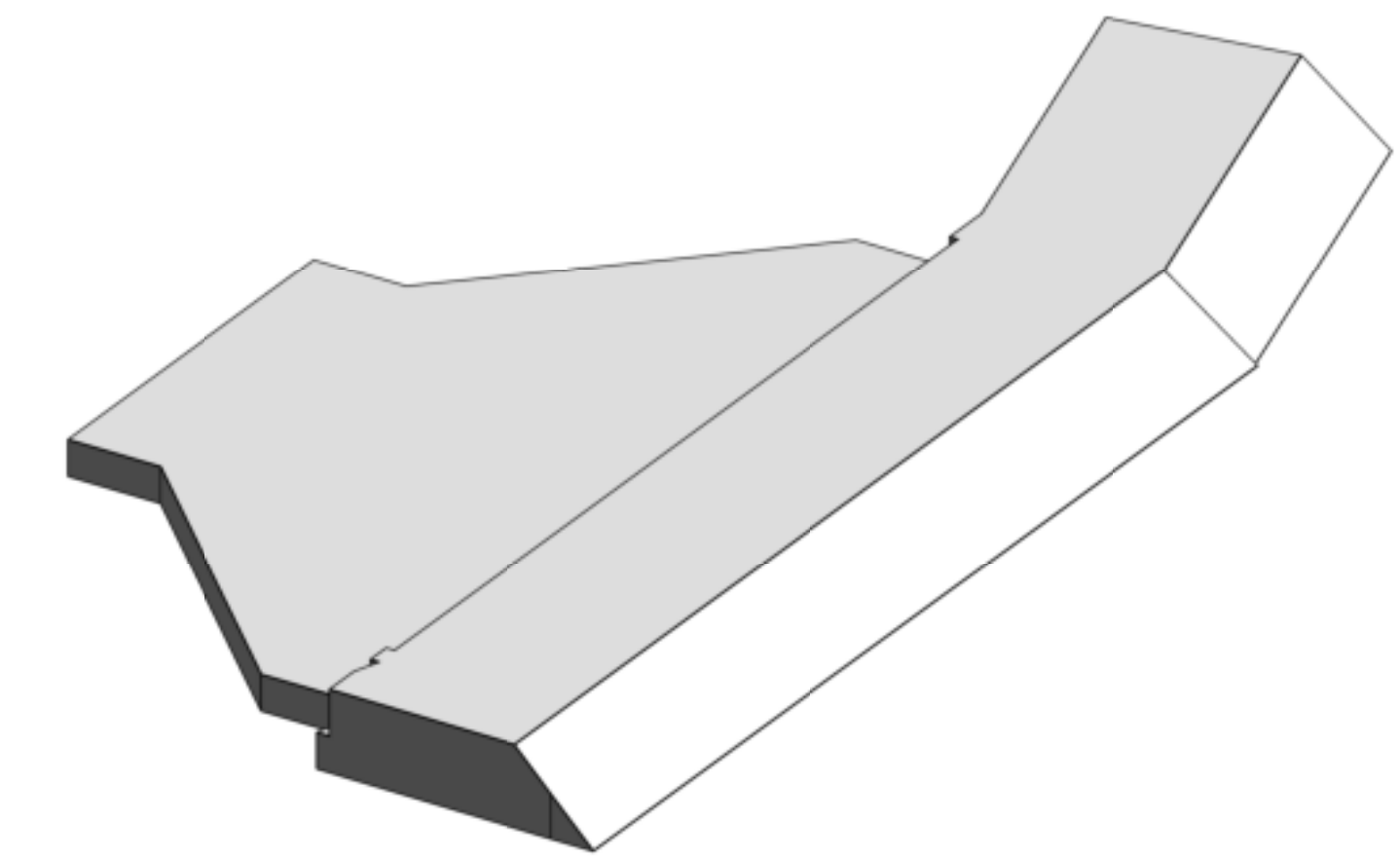
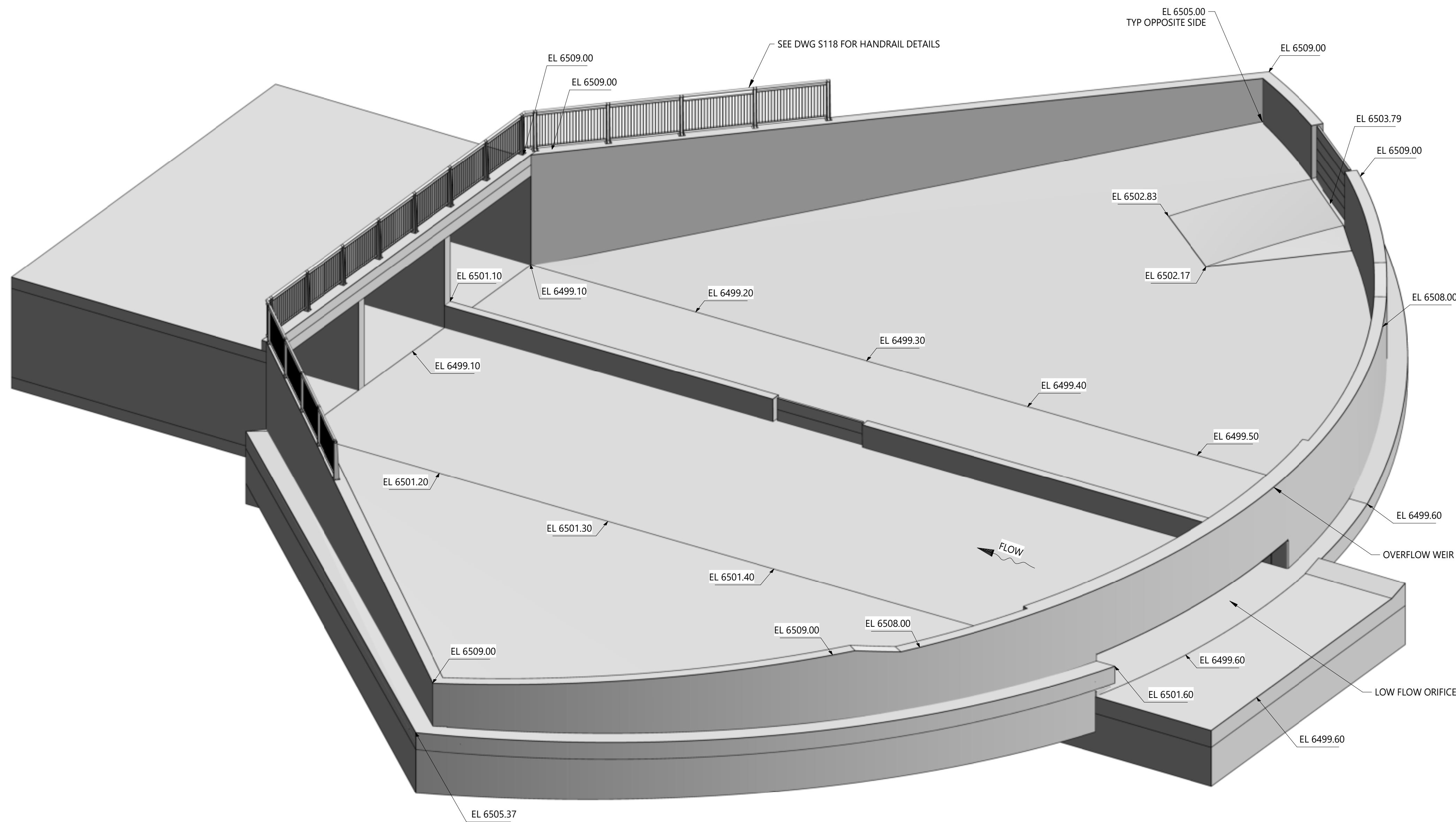

EXISTING SOIL CEMENT
ISOMETRIC

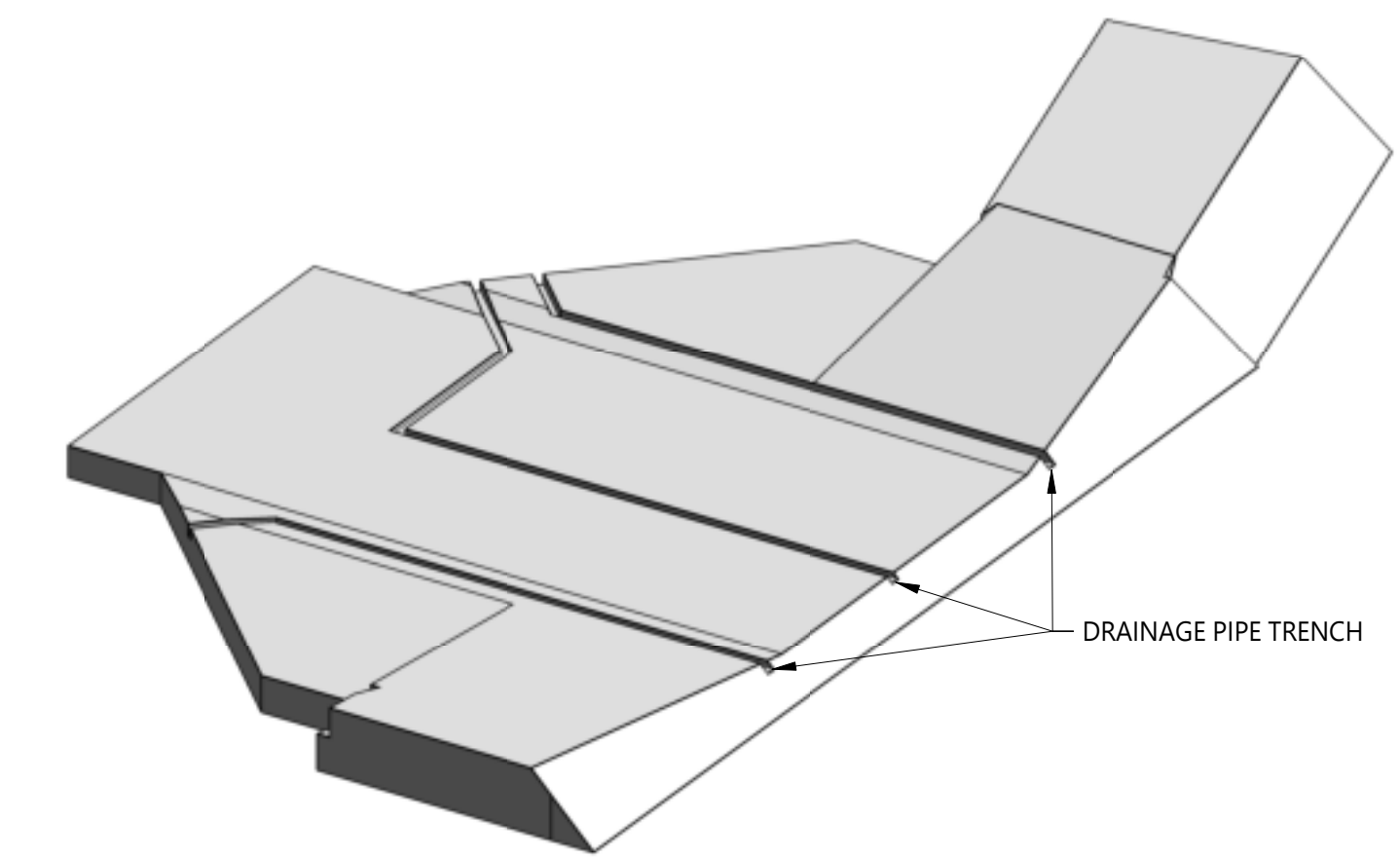

SOIL CEMENT AFTER DEMOLITION
ISOMETRIC

NOTES:

- SEE DRAWING S-100 AND S-101 FOR LEGEND, ABBREVIATIONS, AND GENERAL NOTES.

REV	REVISION DESCRIPTION	DATE	CHND	CHKD	APPR

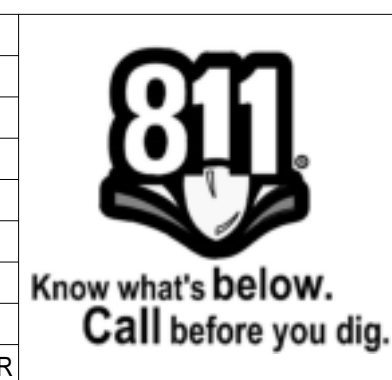

CITY OF COLORADO SPRINGS
30 S. NEVADA AVE., SUITE 401
COLORADO SPRINGS, CO 80903
(719) 385-5980

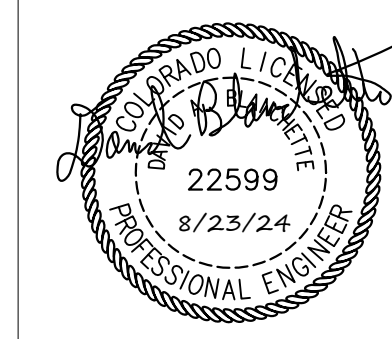

SAND CREEK DETENTION POND NO. 2

POND OUTLET STRUCTURE
ISOMETRIC VIEW

JOB NUMBER	65420975
DATE	8/23/24
DRAWING NO.	S-102
SHEET	35 of 51

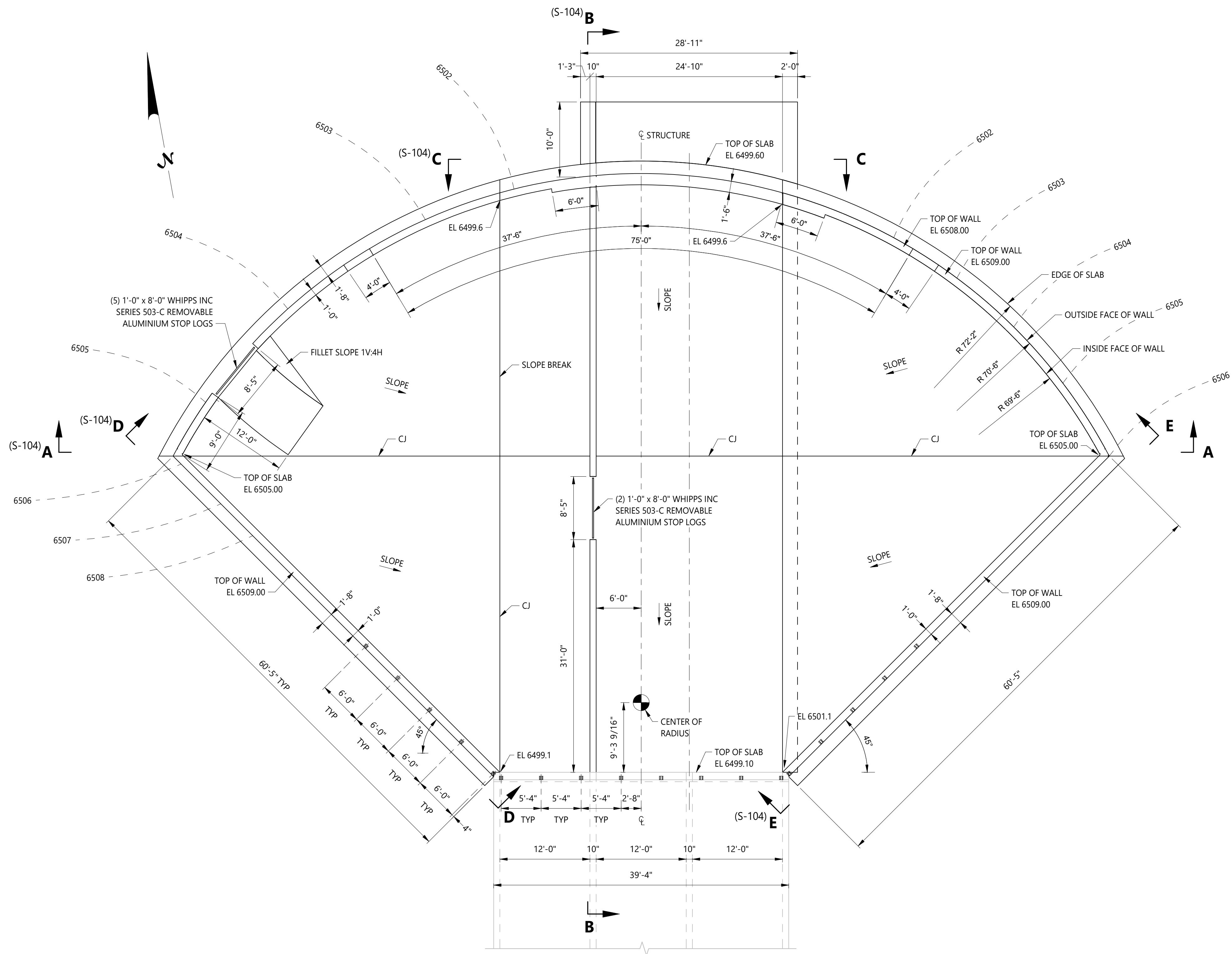

PLAN - POND 2 OUTLET
SCALE: 1/8" = 1'-0"

- NOTES:
- SEE DRAWING S-100 AND S-101 FOR LEGEND, ABBREVIATIONS, AND GENERAL NOTES.
 - DEMO EXISTING WING WALLS, OVERFLOW WALLS, SLAB, AND SOIL CEMENT WITHIN LIMITS OF NEW STRUCTURE.

REV	REVISION DESCRIPTION	DATE	CHND	CHKD	APPR



CITY OF COLORADO SPRINGS
30 S. NEVADA AVE., SUITE 401
COLORADO SPRINGS, CO 80903
(719) 385-5980

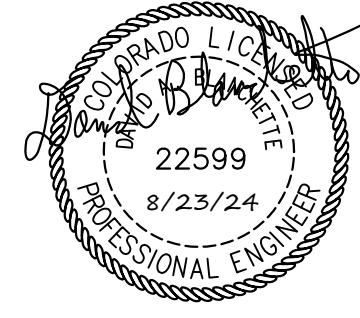

SAND CREEK DETENTION POND NO. 2
POND OUTLET STRUCTURE
OUTLINE PLAN

JOB NUMBER	65420975
DATE	8/23/24
DRAWING NO.	S-103
SHEET	36 of 51

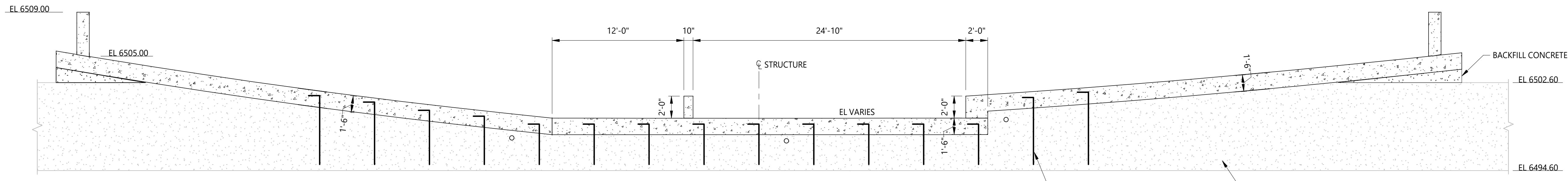

SECTION A - A (S-103)

SCALE: 3/16" = 1'-0"

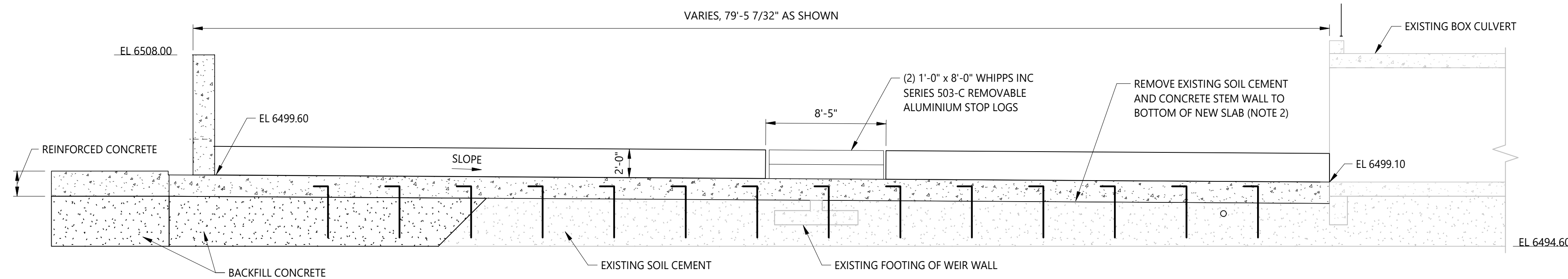

SECTION B - B (S-103)

SCALE: 3/16" = 1'-0"

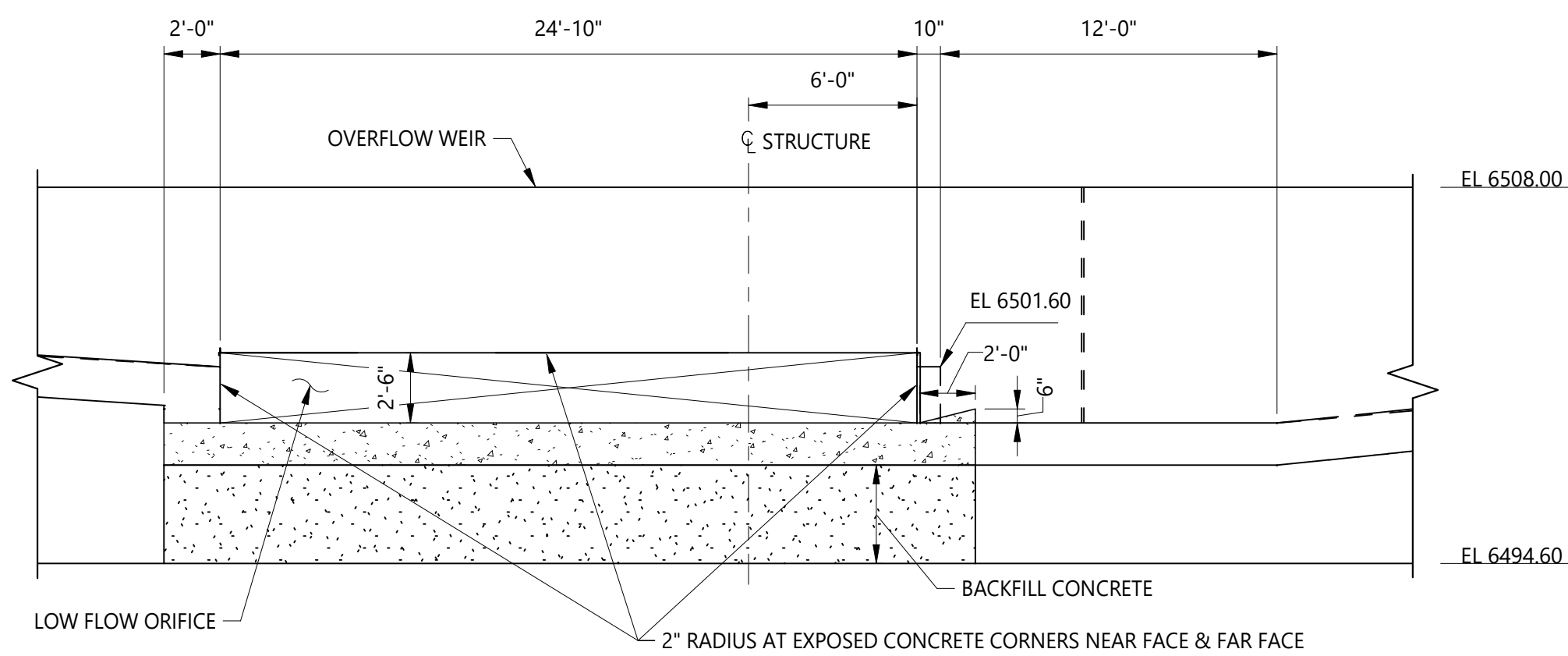

SECTION C - C (S-103)

SCALE: 3/16" = 1'-0"

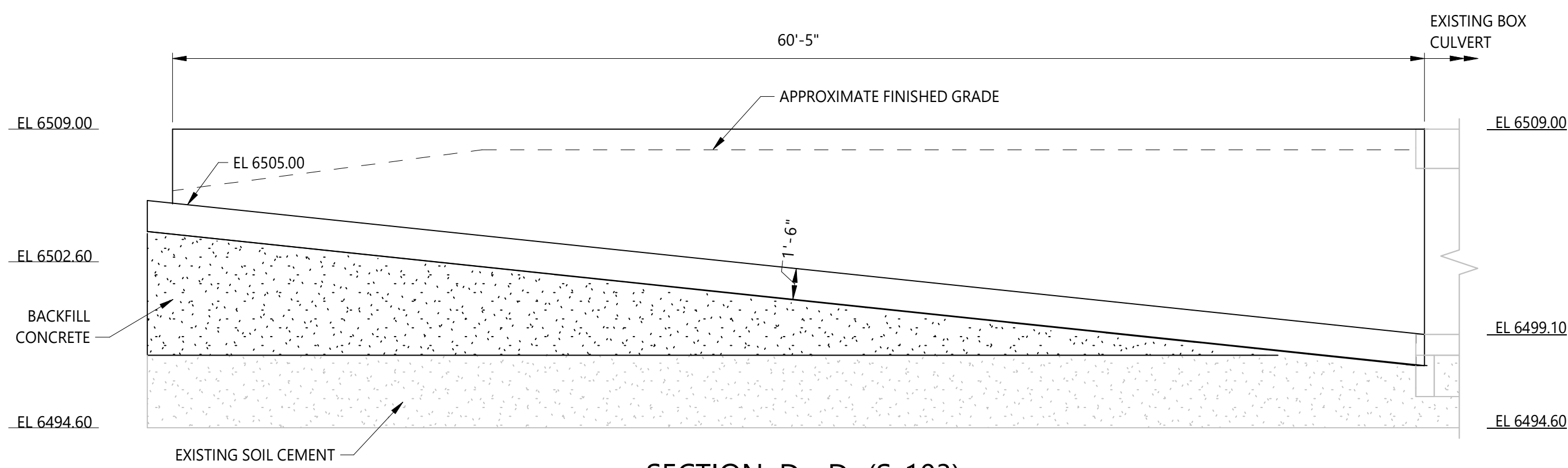

SECTION D - D (S-103)

SCALE: 3/16" = 1'-0"

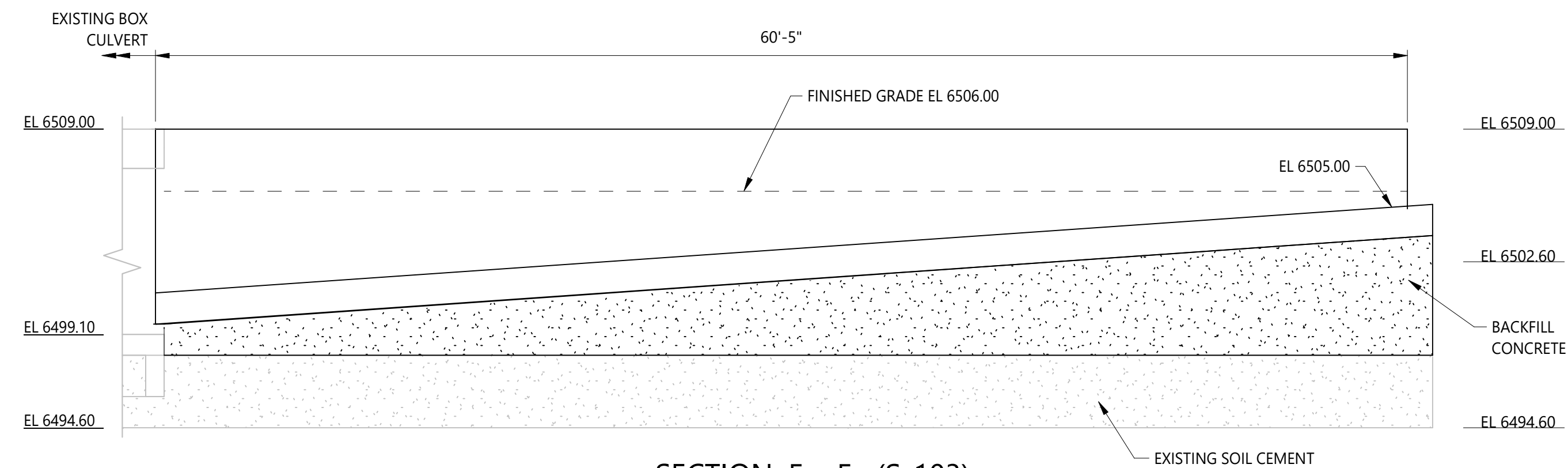

SECTION E - E (S-103)

SCALE: 3/16" = 1'-0"

NOTES:

1. SEE DRAWING S-100 AND S-101 FOR LEGEND, ABBREVIATIONS, AND GENERAL NOTES.
2. PROTECT SOIL CEMENT TO REMAIN.

REV	REVISION DESCRIPTION	DATE	CHND	CHKD	APPR



CITY OF COLORADO SPRINGS
30 S. NEVADA AVE., SUITE 401
COLORADO SPRINGS, CO 80903
(719) 385-5980

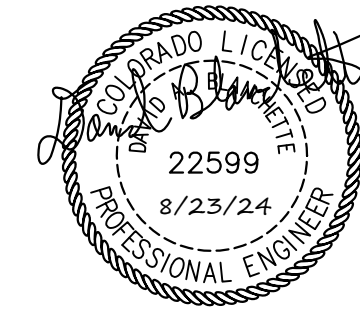

SAND CREEK DETENTION POND NO. 2

POND OUTLET STRUCTURE
OUTLINE SECTIONS

JOB NUMBER	65420975
DATE	8/23/24
DRAWING NO.	S-104
SHEET	37 of 51

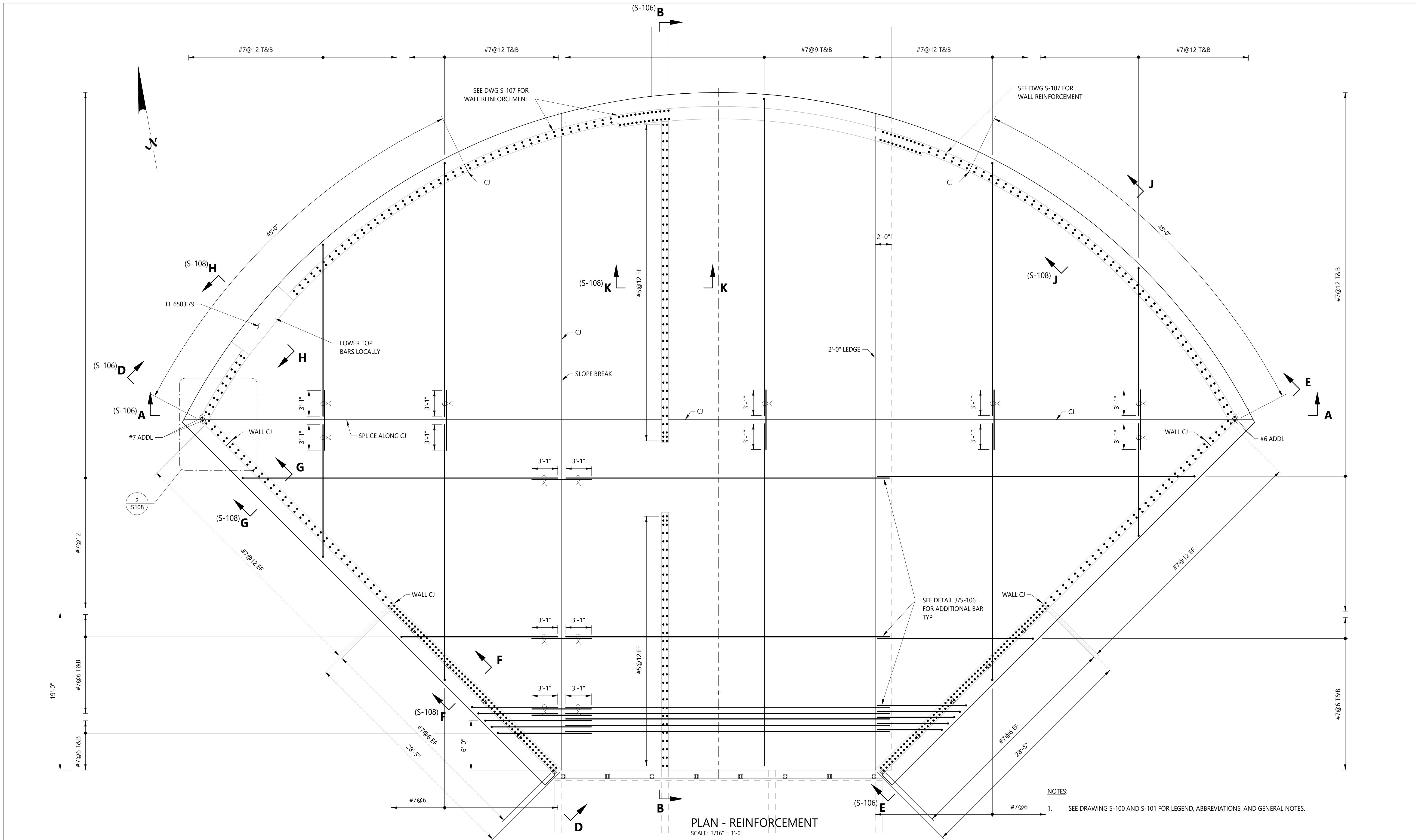

PLAN - REINFORCEMENT
SCALE: 3/16" = 1'-0"

NOTES:
1. SEE DRAWING S-100 AND S-101 FOR LEGEND, ABBREVIATIONS, AND GENERAL NOTES.

REV	REVISION DESCRIPTION	DATE	CHND	CHKD	APPR



CITY OF COLORADO SPRINGS
30 S. NEVADA AVE., SUITE 401
COLORADO SPRINGS, CO 80903
(719) 385-5980

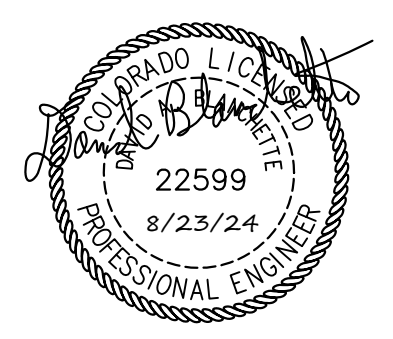
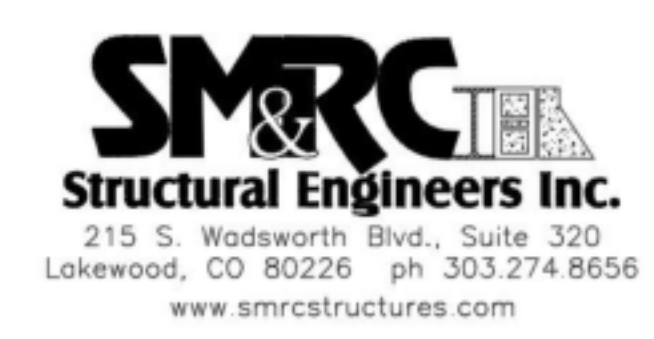

SAND CREEK DETENTION POND NO. 2
POND 5 BOX CULVERT
POND OUTLET STRUCTURE
REINFORCEMENT PLAN

JOB NUMBER	65420975
DATE	8/23/24
DRAWING NO.	S-105
SHEET	38 of 51

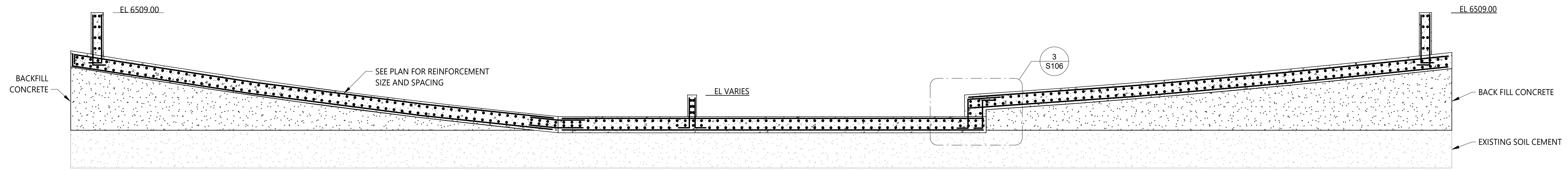

SECTION A - A (S-105)
SCALE: 3/16" = 1'-0"

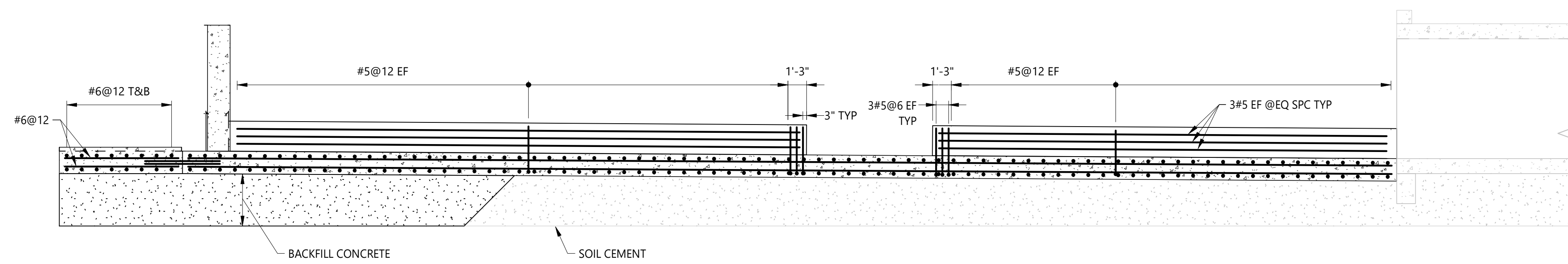

SECTION B - B (S-105)
SCALE: 3/16" = 1'-0"

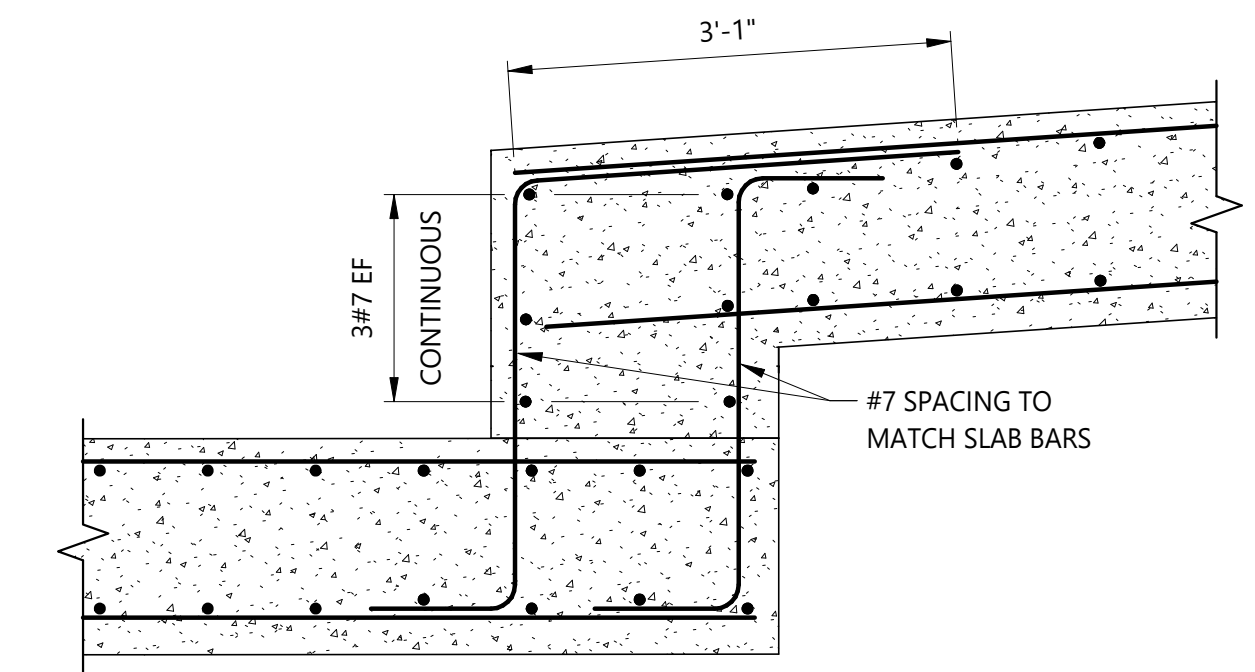

DETAIL 3
SCALE: 3/4" = 1'-0"

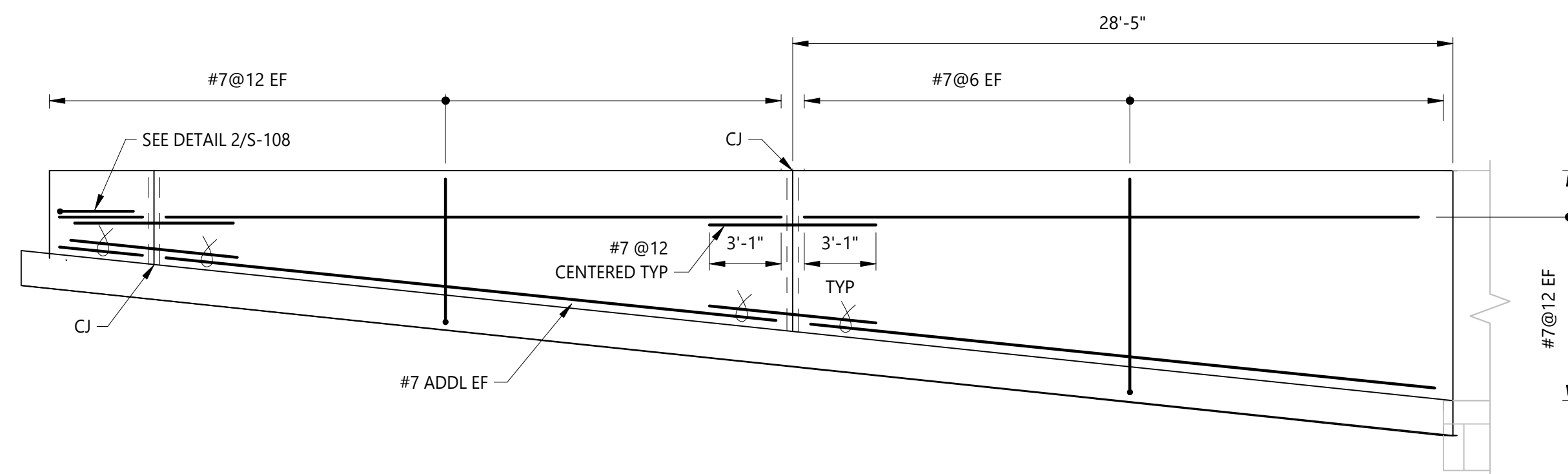

SECTION D - D (S-105)
SCALE: 3/16" = 1'-0"

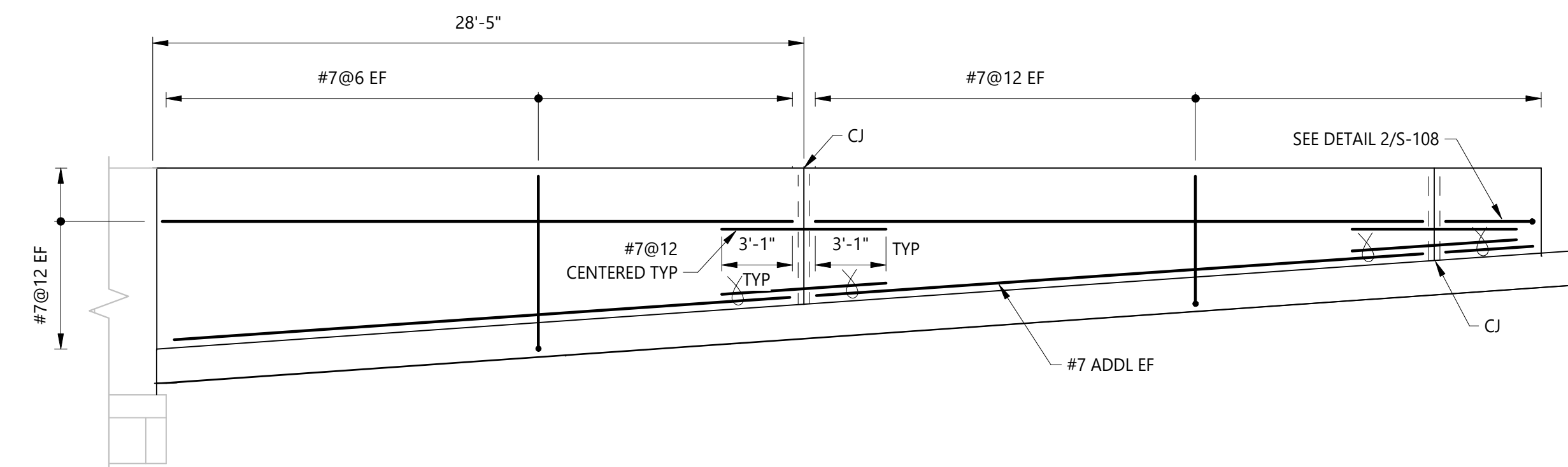

SECTION E - E (S-105)
SCALE: 3/16" = 1'-0"

REV	REVISION DESCRIPTION	DATE	CHND	CHKD	APPR

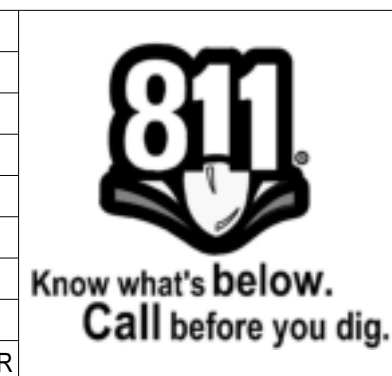

CITY OF COLORADO SPRINGS
30 S. NEVADA AVE., SUITE 401
COLORADO SPRINGS, CO 80903
(719) 385-5980

SMRC
Structural Engineers Inc.
215 S. Wadsworth Blvd., Suite 320
Lakewood, CO 80226 ph 303.274.8656
www.smrstructures.com

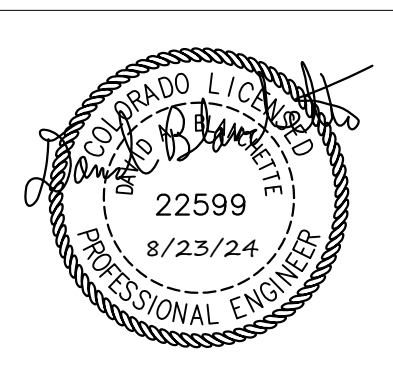

SAND CREEK DETENTION POND NO. 2

POND OUTLET STRUCTURE
REINFORCEMENT SECTIONS

JOB NUMBER	65420975
DATE	8/23/24
DRAWING NO.	S-106
SHEET	39 of 51

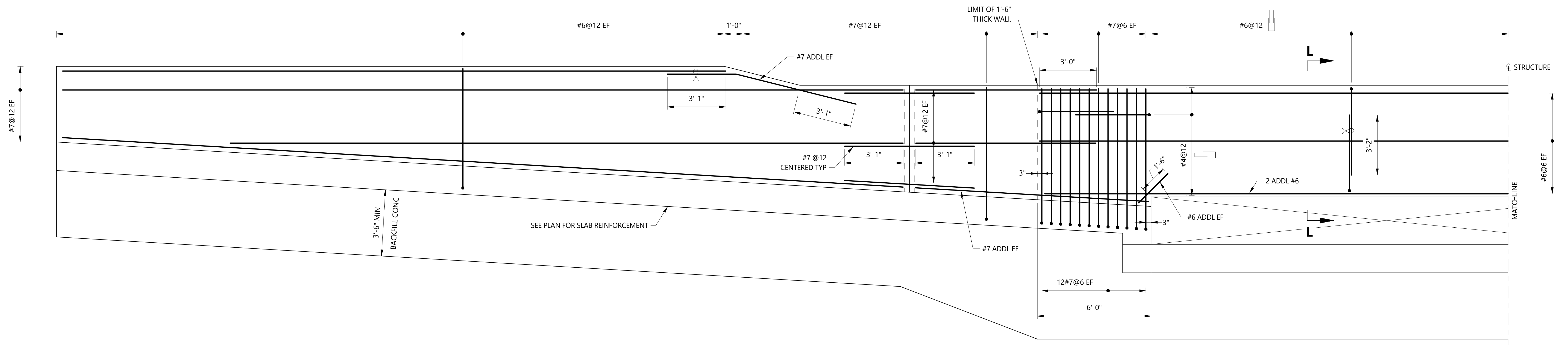

ELEVATION - CURVED WEIR WALL (LOOKING SOUTH)
SCALE: 3/8" = 1'-0"

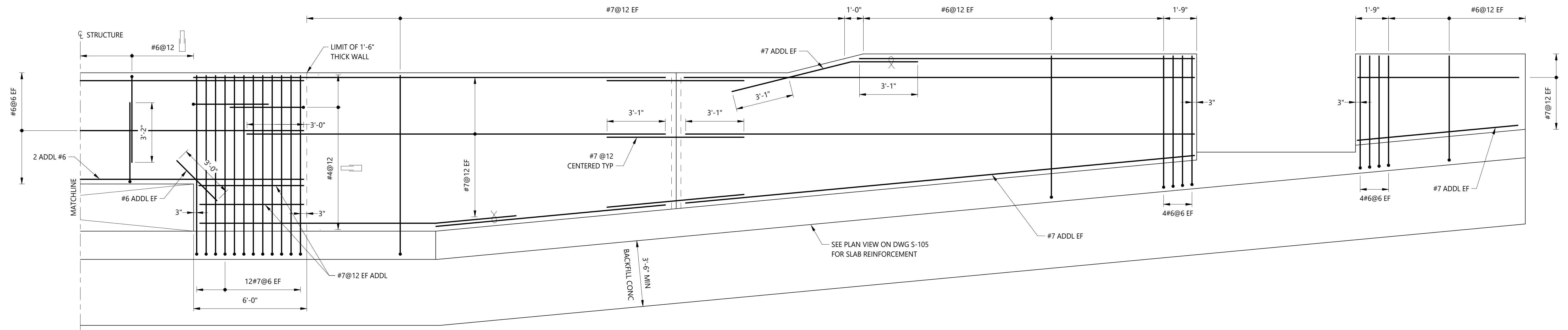

ELEVATION - CURVED WEIR WALL (LOOKING SOUTH)
SCALE: 3/8" = 1'-0"

REV	REVISION DESCRIPTION	DATE	CHND	CHKD	APPR



CITY OF COLORADO SPRINGS
30 S. NEVADA AVE., SUITE 401
COLORADO SPRINGS, CO 80903
(719) 385-5980

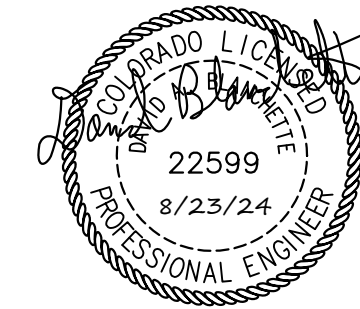

SAND CREEK DETENTION POND NO. 2

POND OUTLET STRUCTURE
REINFORCEMENT SECTIONS

JOB NUMBER	65420975
DATE	8/23/24
DRAWING NO.	S-107
SHEET	40 of 51

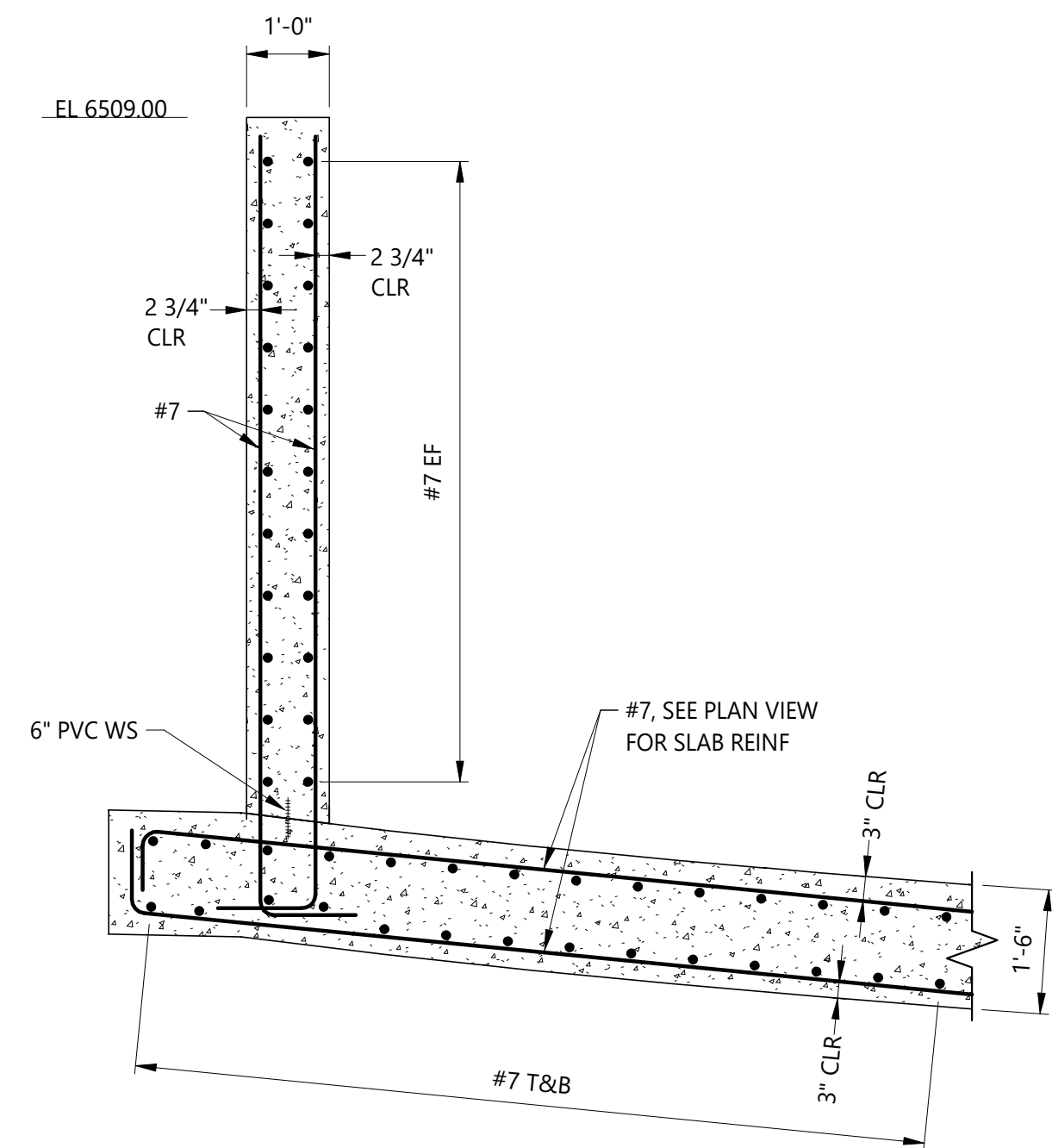

SECTION F - F (S-105)
SCALE: 1/2" = 1'-0"

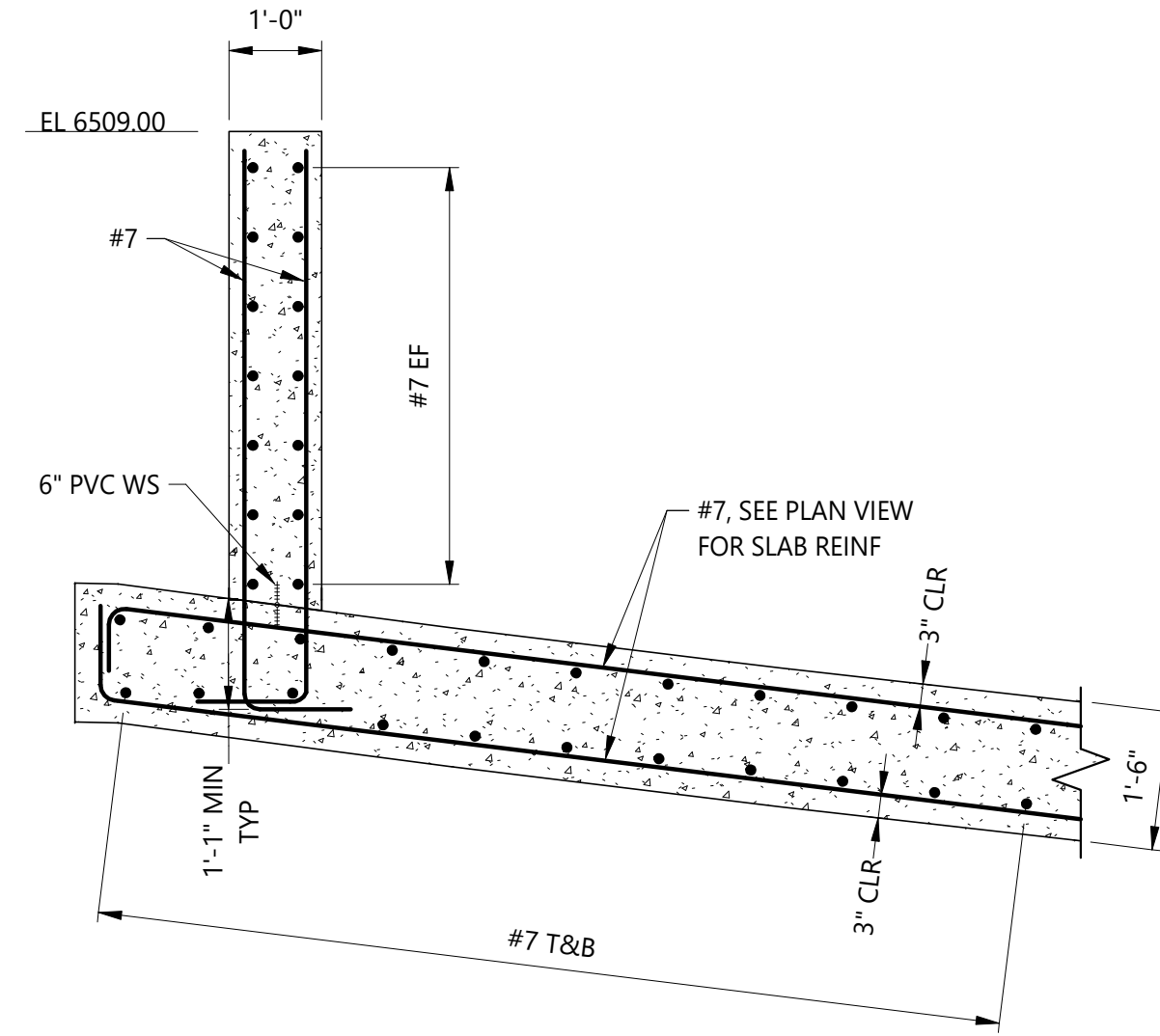

SECTION G - G (S-105)
SCALE: 1/2" = 1'-0"

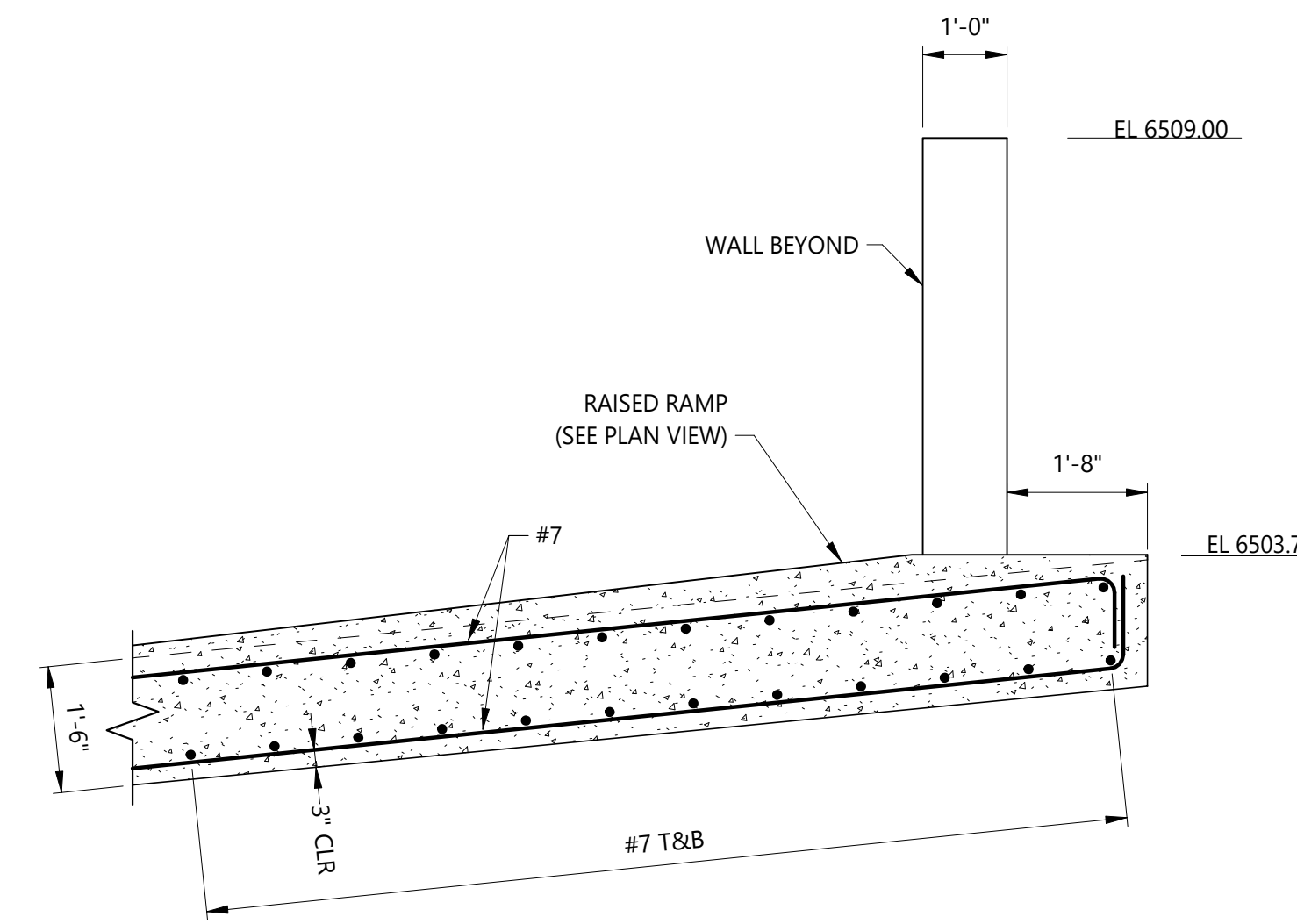

SECTION H - H (S-105)
SCALE: 1/2" = 1'-0"

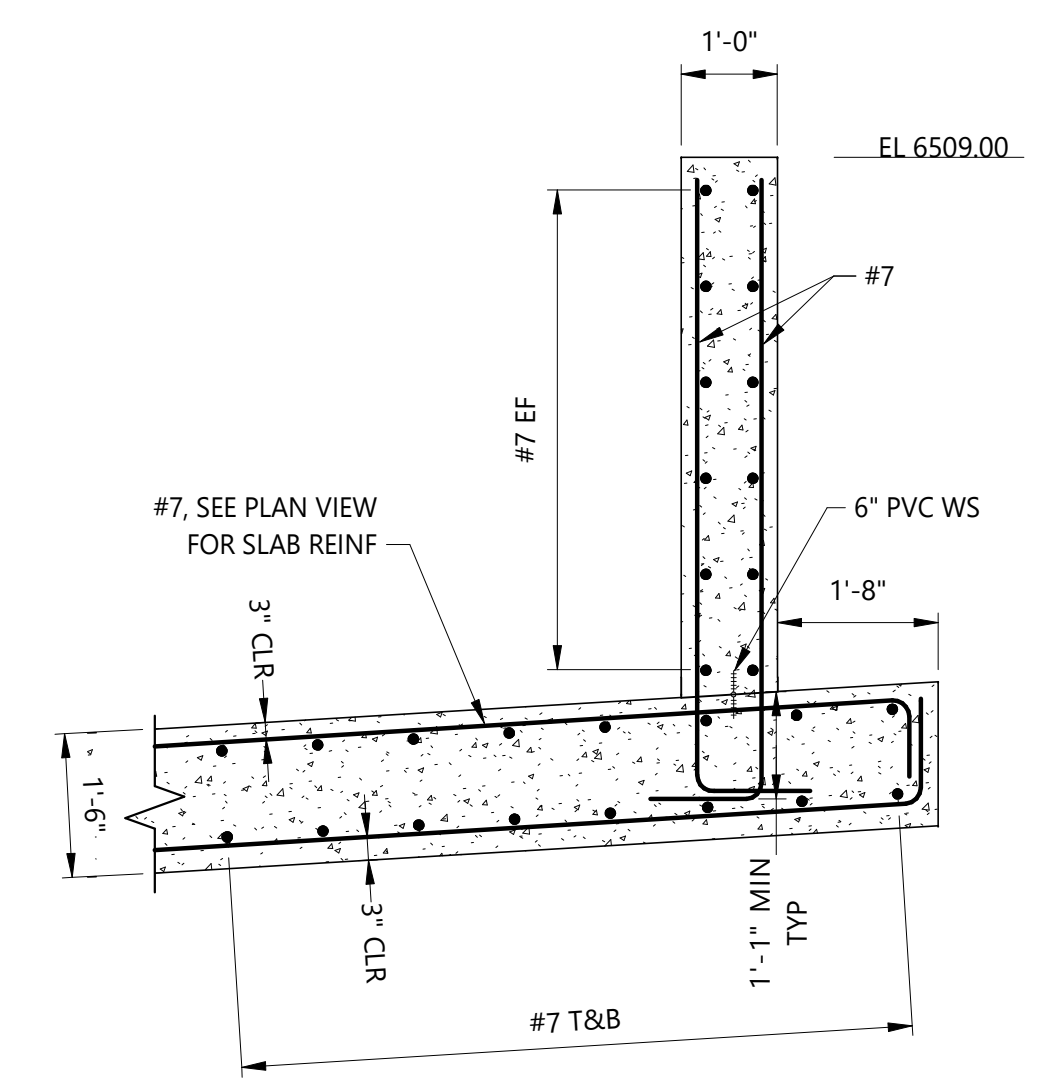

SECTION J - J (S-105)
SCALE: 1/2" = 1'-0"

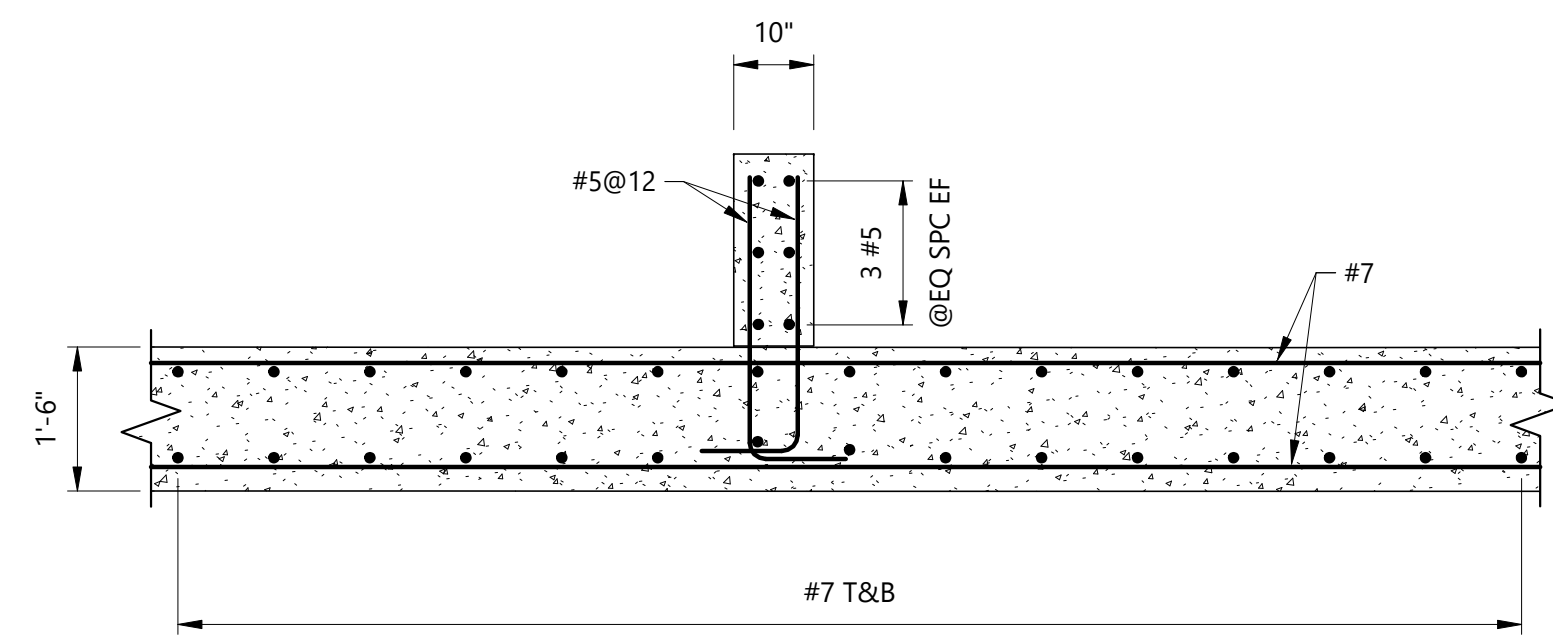

SECTION K - K (S-105)
SCALE: 1/2" = 1'-0"

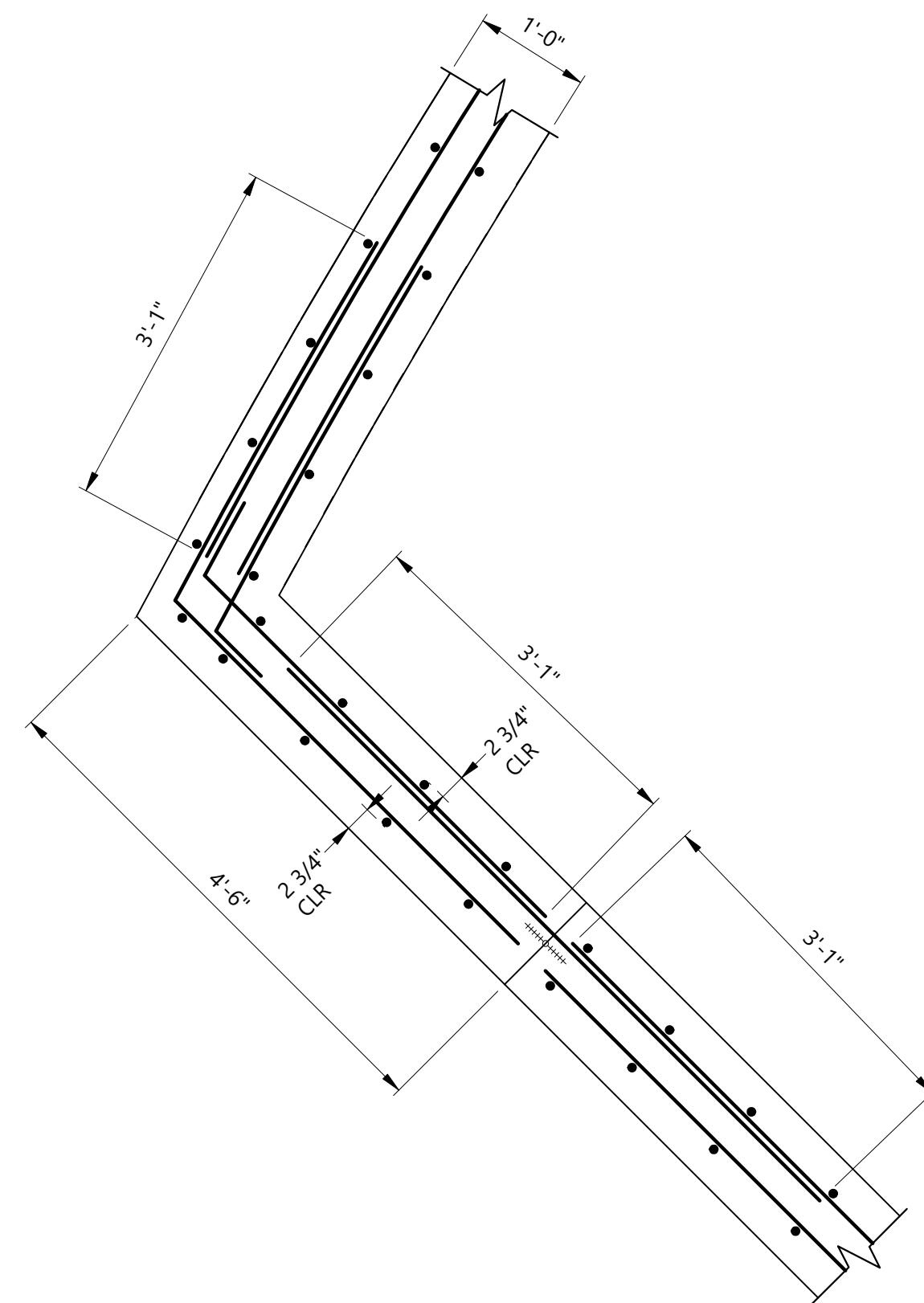

DETAIL 2 (S-105)
SCALE: 3/4" = 1'-0"

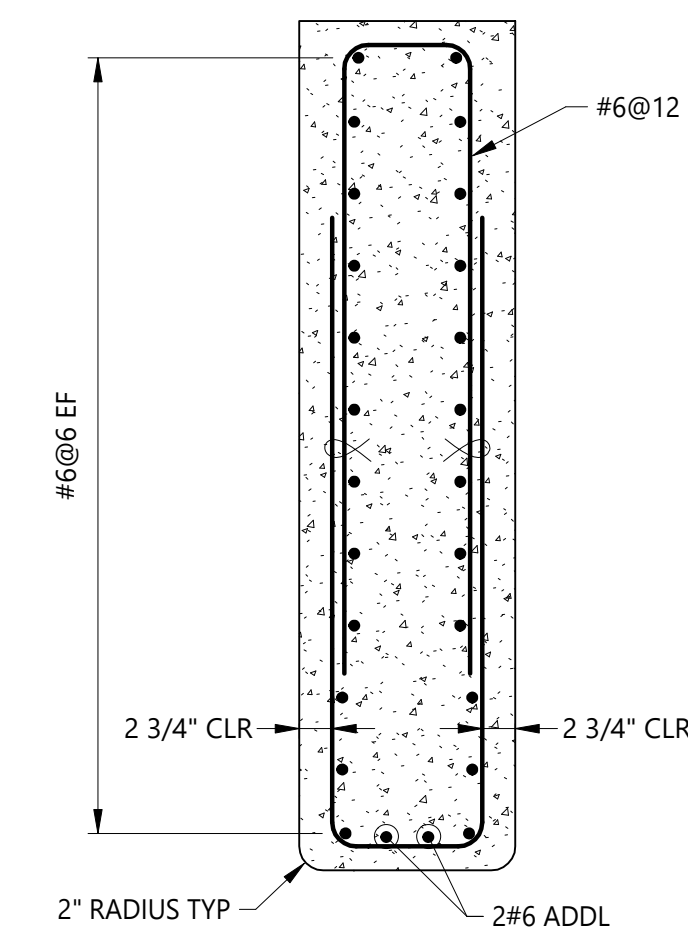

SECTION L-L (S-107)
SCALE: 3/4" = 1'-0"

REV	REVISION DESCRIPTION	DATE	CHND	CHKD	APPR



CITY OF COLORADO SPRINGS
30 S. NEVADA AVE., SUITE 401
COLORADO SPRINGS, CO 80903
(719) 385-5980

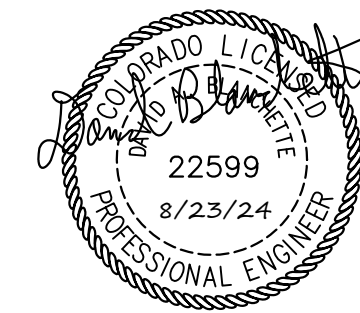

SAND CREEK DETENTION POND NO. 2

POND OUTLET STRUCTURE
REINFORCEMENT SECTIONS

JOB NUMBER	65420975
DATE	8/23/24
DRAWING NO.	S-108
SHEET	41 of 51

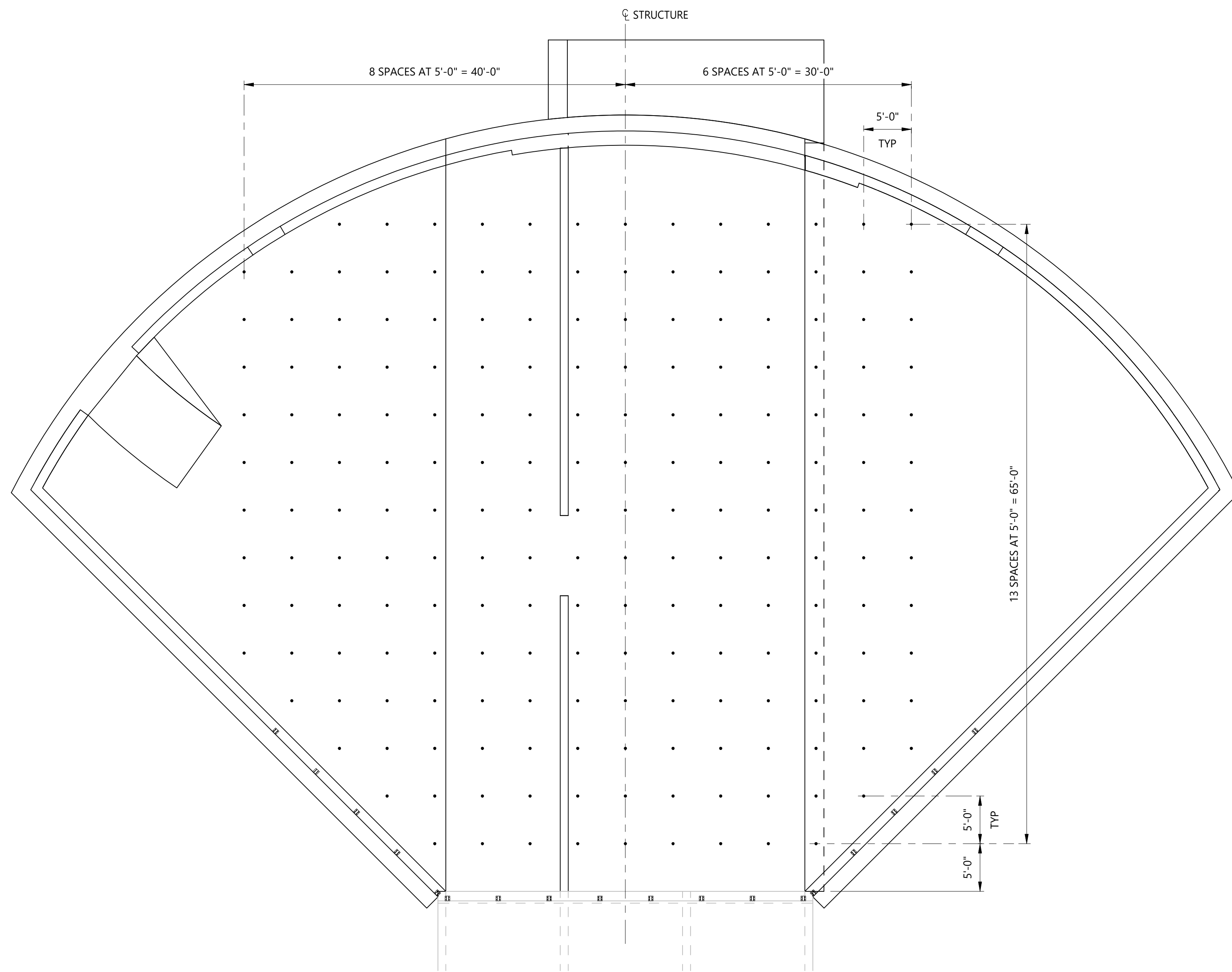

PLAN - DOWEL ANCHORS
SCALE: 1/8" = 1'-0"

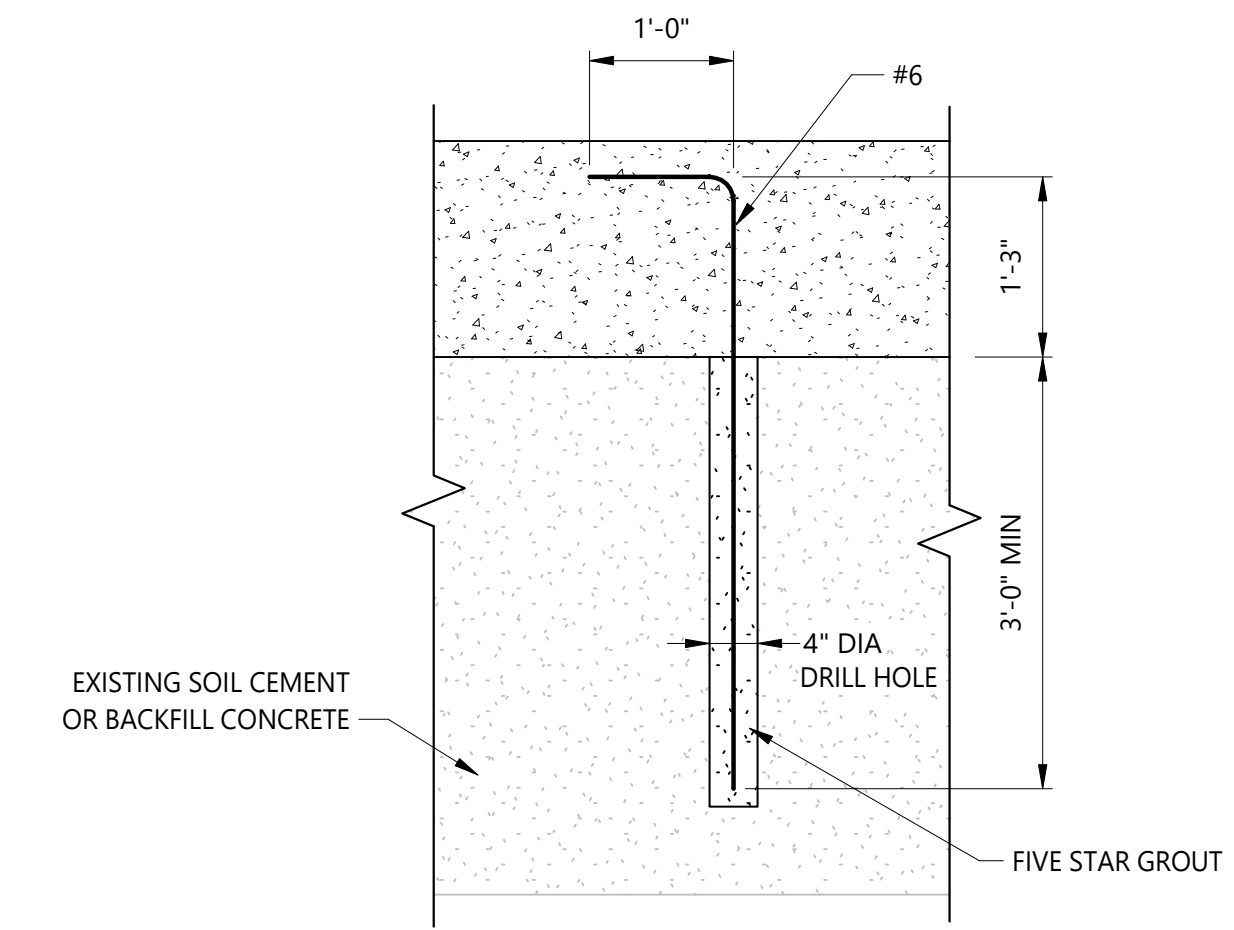

ANCHOR DETAIL
SCALE: 3/4" = 1'-0"

REV	REVISION DESCRIPTION	DATE	CHND	CHKD	APPR



CITY OF COLORADO SPRINGS
30 S. NEVADA AVE., SUITE 401
COLORADO SPRINGS, CO 80903
(719) 385-5980

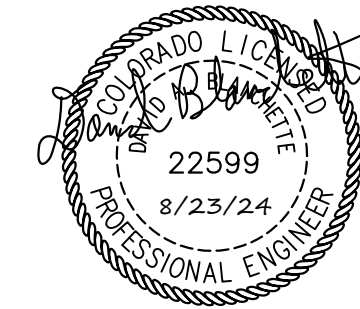

SAND CREEK DETENTION POND NO. 2

POND OUTLET STRUCTURE
DOWEL ANCHOR PLAN AND DETAILS

JOB NUMBER	65420975
DATE	8/23/24
DRAWING NO.	S-109
SHEET	42 of 51

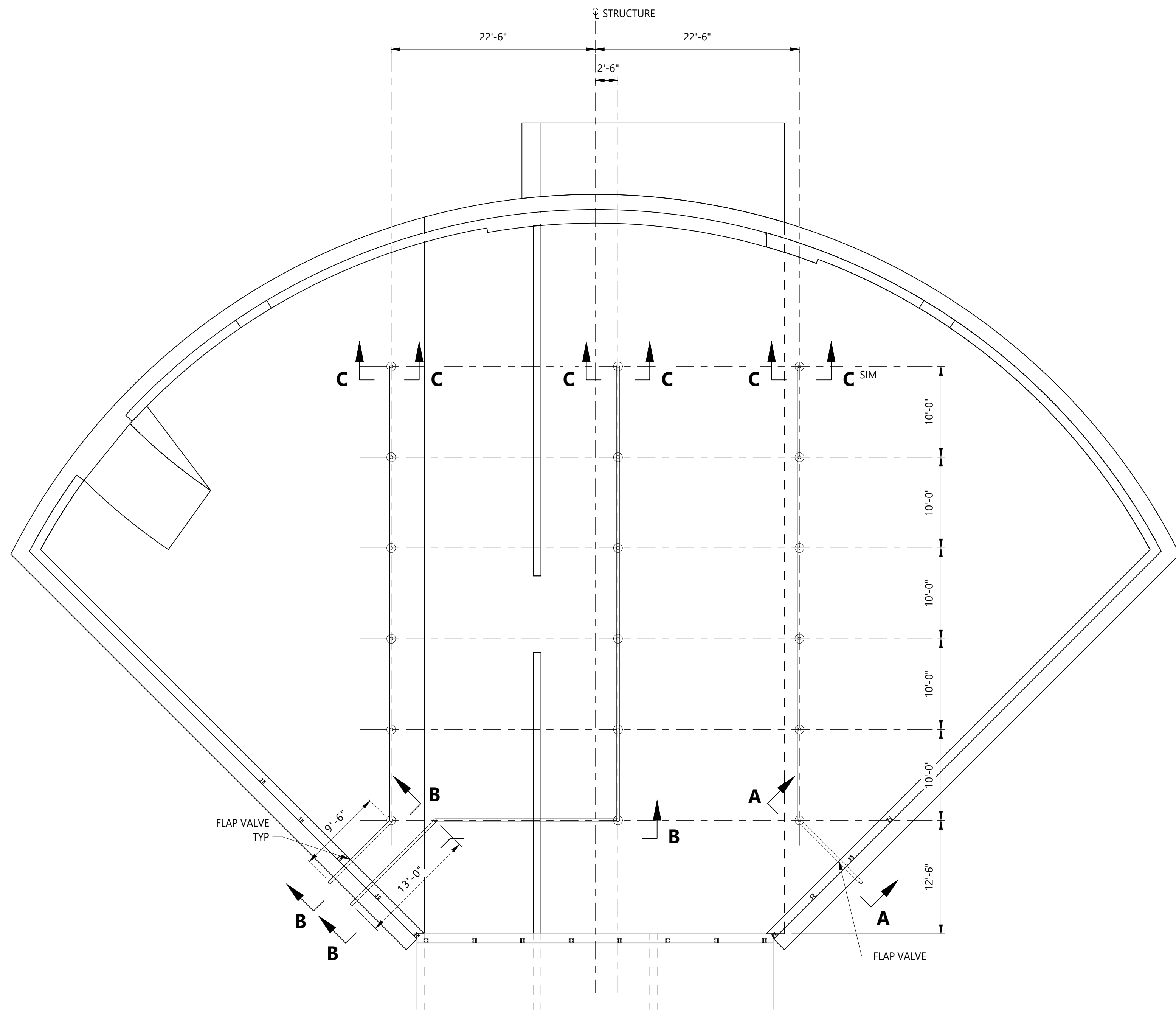

PLAN - DRAIN SYSTEM
SCALE: 1/8" = 1'-0"

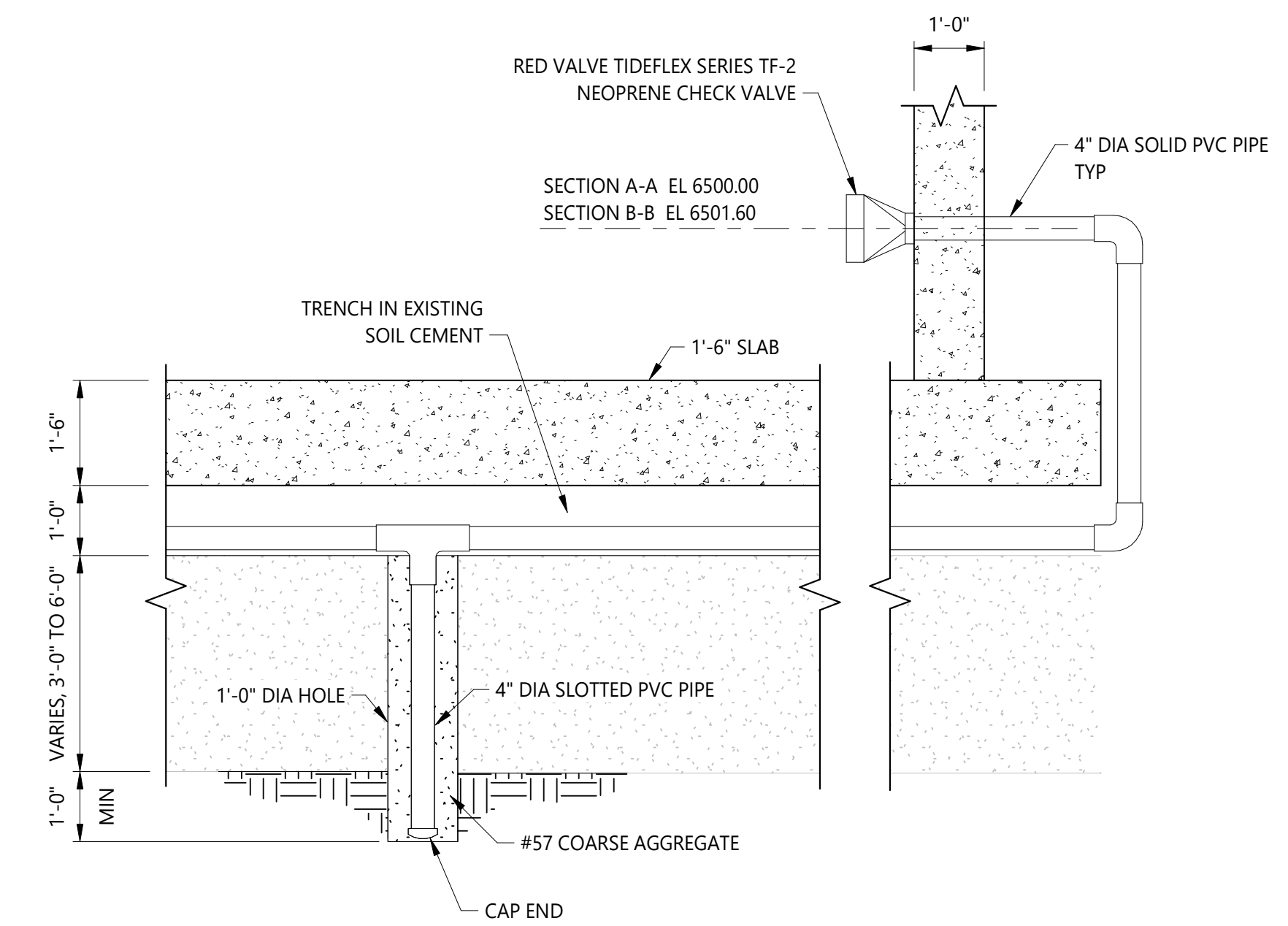

SECTION A-A - DRAINAGE PIPE (SECTION B-B SIMILAR)
SCALE: 1/2" = 1'-0"

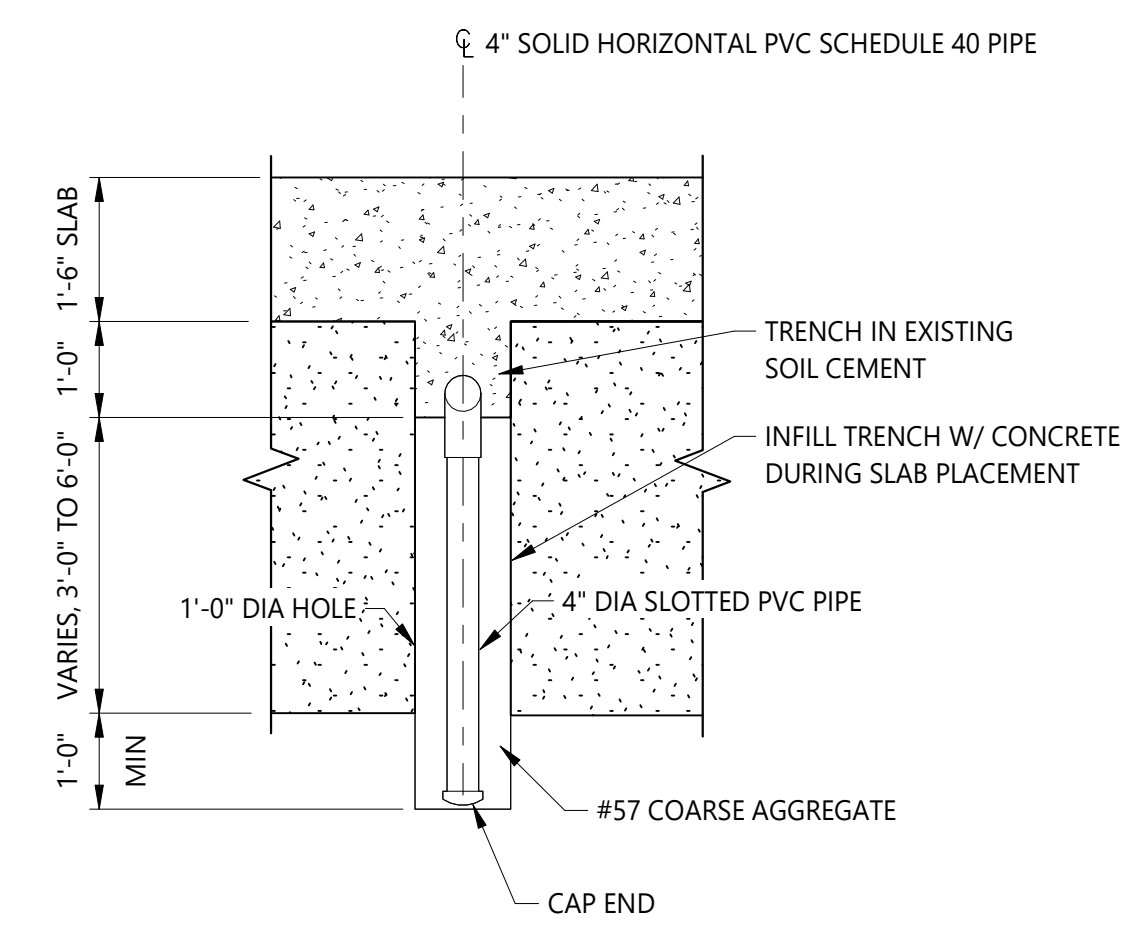

SECTION C-C - DRAINAGE PIPE
SCALE: 1/2" = 1'-0"

REV	REVISION DESCRIPTION	DATE	CHND	CHKD	APPR



CITY OF COLORADO SPRINGS
30 S. NEVADA AVE., SUITE 401
COLORADO SPRINGS, CO 80903
(719) 385-5980

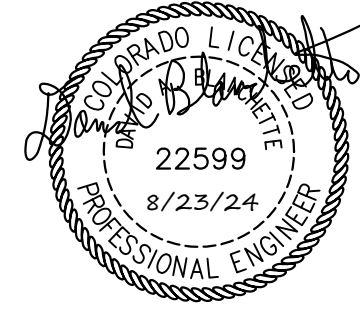
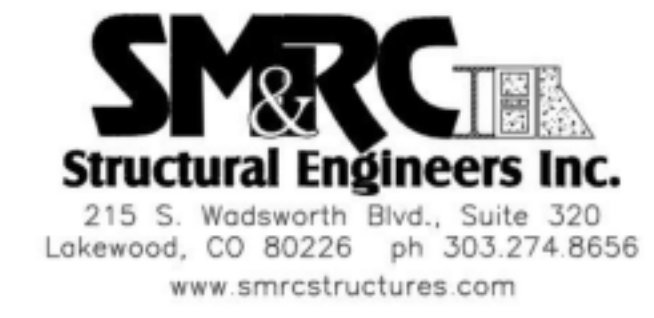

SAND CREEK DETENTION POND NO. 2
POND OUTLET STRUCTURE
UNDER DRAIN PLAN AND DETAILS

JOB NUMBER	65420975
DATE	8/23/24
DRAWING NO.	S-110
SHEET	43 of 51

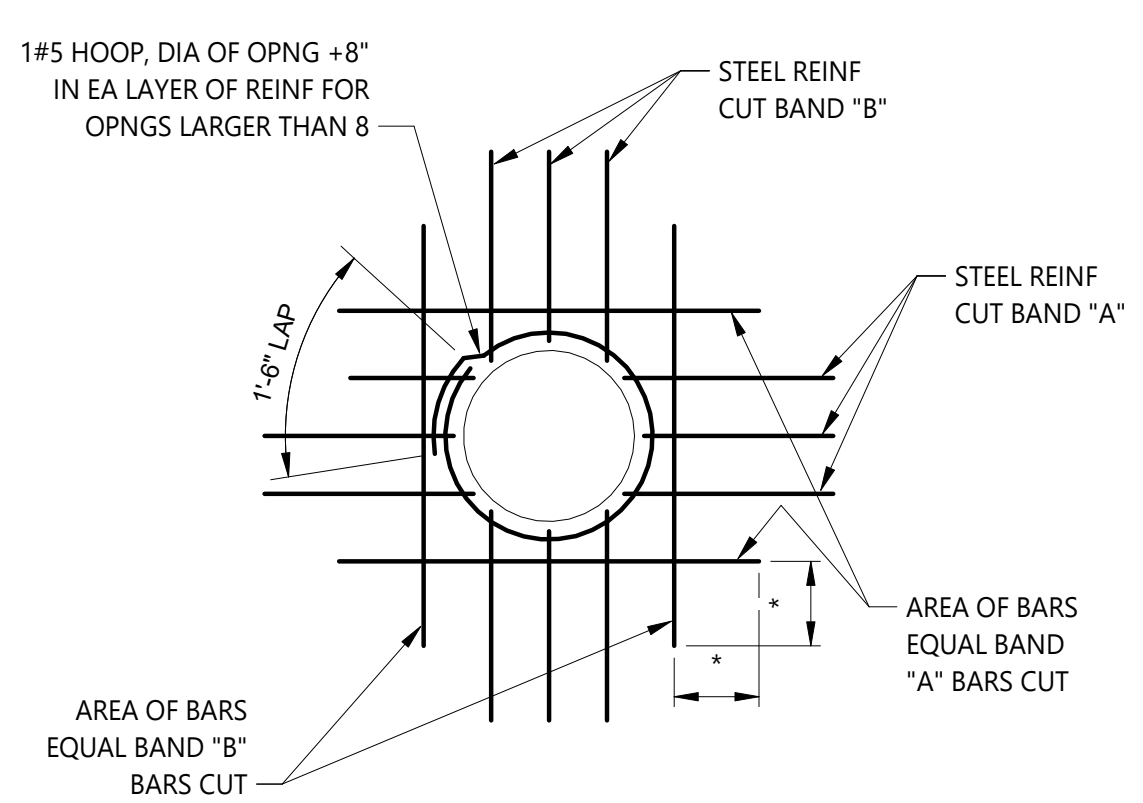

- OPENING REINFORCEMENT NOTES:**
1. TYPICAL FOR ALL OPENINGS IN CONCRETE WALLS AND SLABS UNLESS INDICATED OTHERWISE ON PLANS.
 2. DO NOT WELD REINFORCEMENT TO PIPE SLEEVES AND INSERTS.
 3. PROVIDE A MINIMUM OF (2) "A" BARS AND (2) "B" BARS EACH SIDE OF OPENING (ONE EACH FACE).
 4. SPACE AT 3 BAR DIAMETERS ON CENTER (3" MINIMUM).
 5. * PROVIDE MINIMUM LAP AS NOTED OR SHOWN ON PLANS, TYPICAL. PROVIDE STD HOOK IF FULL LAP LENGTH IS NOT POSSIBLE.

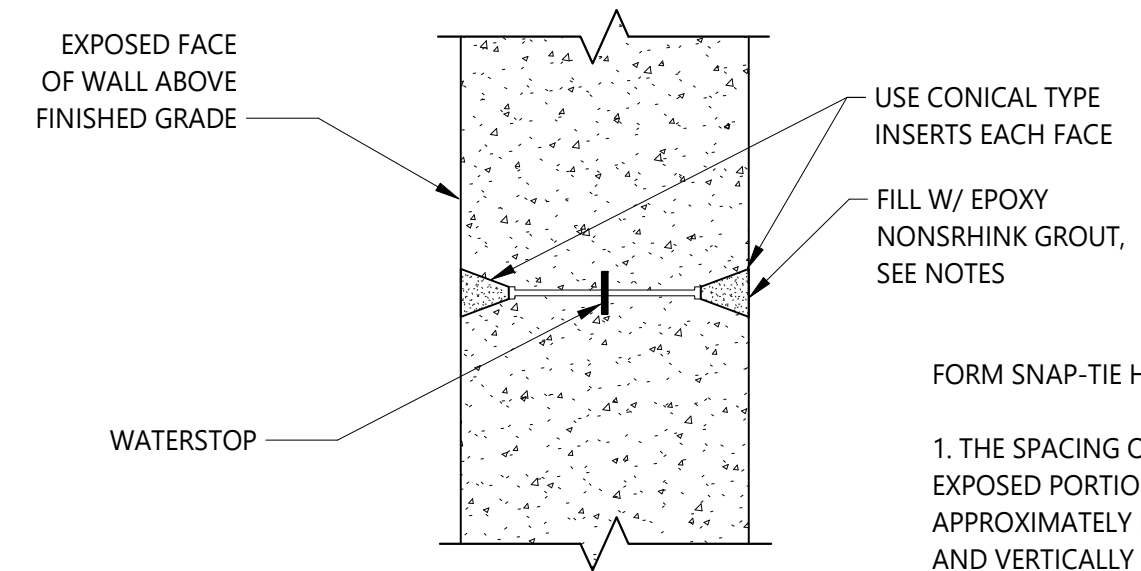
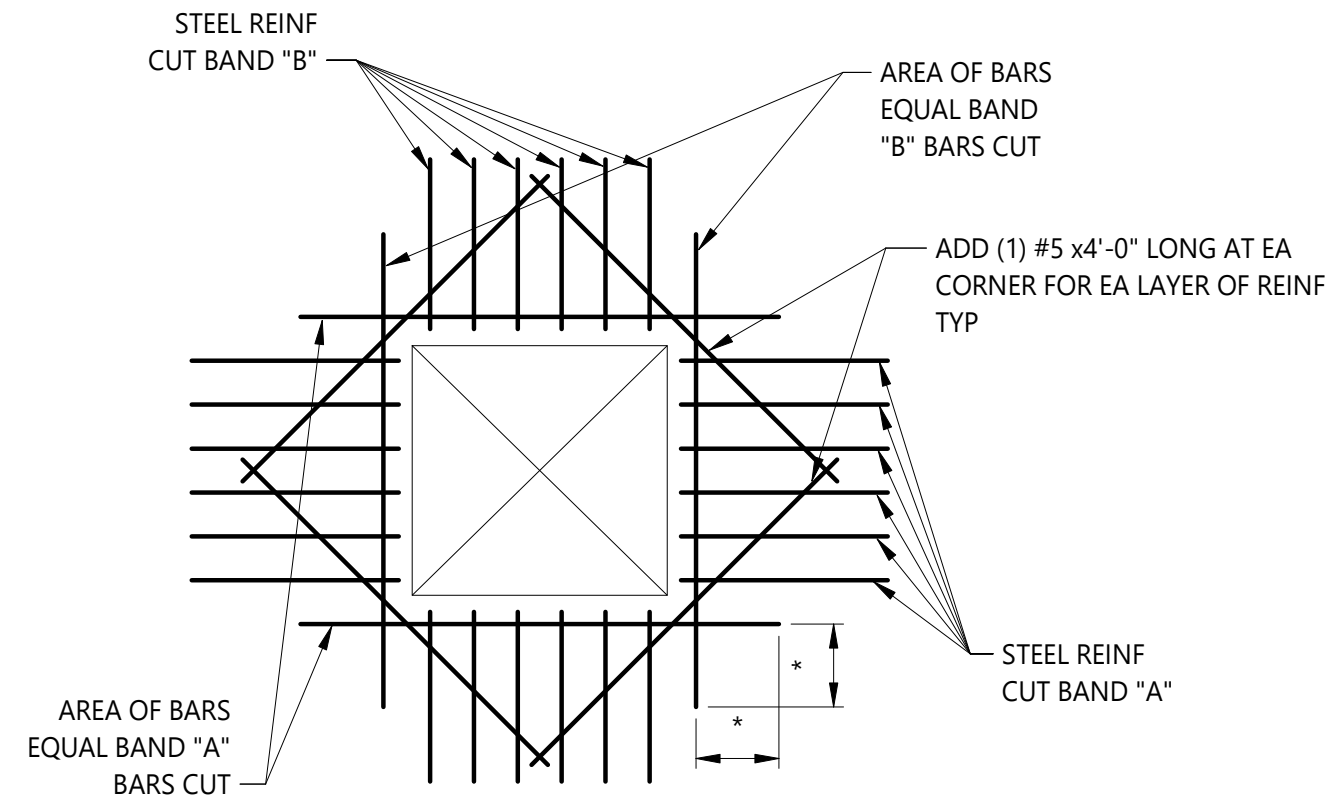

- FORM SNAP-TIE HOLE NOTES:**
1. THE SPACING OF FORM TIES ON EXPOSED PORTIONS OF WALLS SHALL BE APPROXIMATELY EQUAL HORIZONTALLY AND VERTICALLY AND SHALL BE UNIFORM IN EACH DIRECTION.
 2. DRY PACK TIE HOLES WITH EPOXY NON SHRINK GROUT WITH COLOR OF GROUT TO MATCH COLOR OF CONCRETE.

TYPICAL FORM SNAP - TIE JOINT
SCALE: N.T.S.

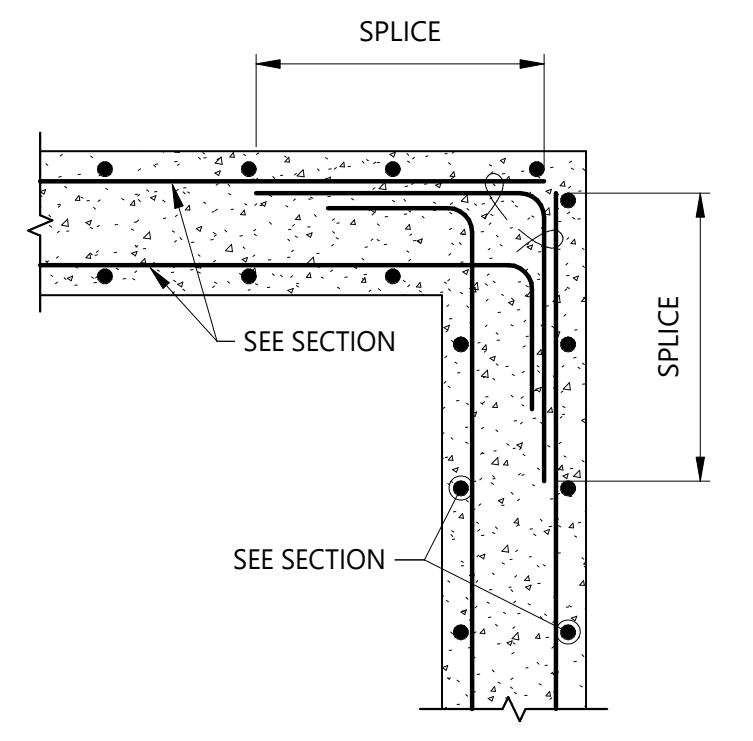

TYPICAL CORNER INTERSECTION
SCALE: N.T.S.

DETAIL 1 - TYPICAL OPENING REINFORCEMENT
DETAIL N.T.S.

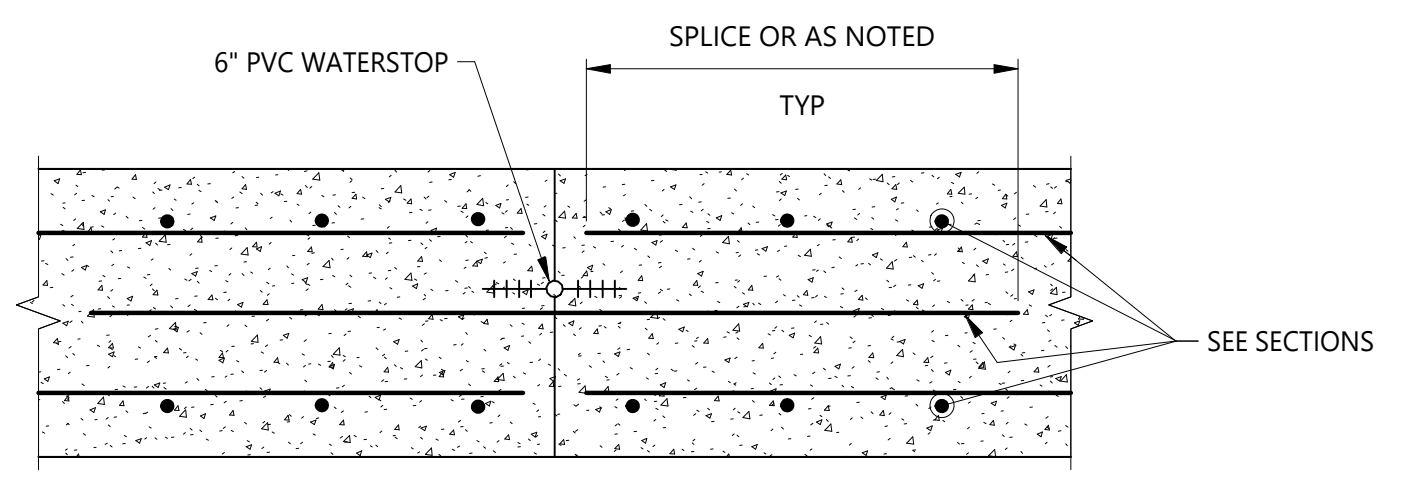
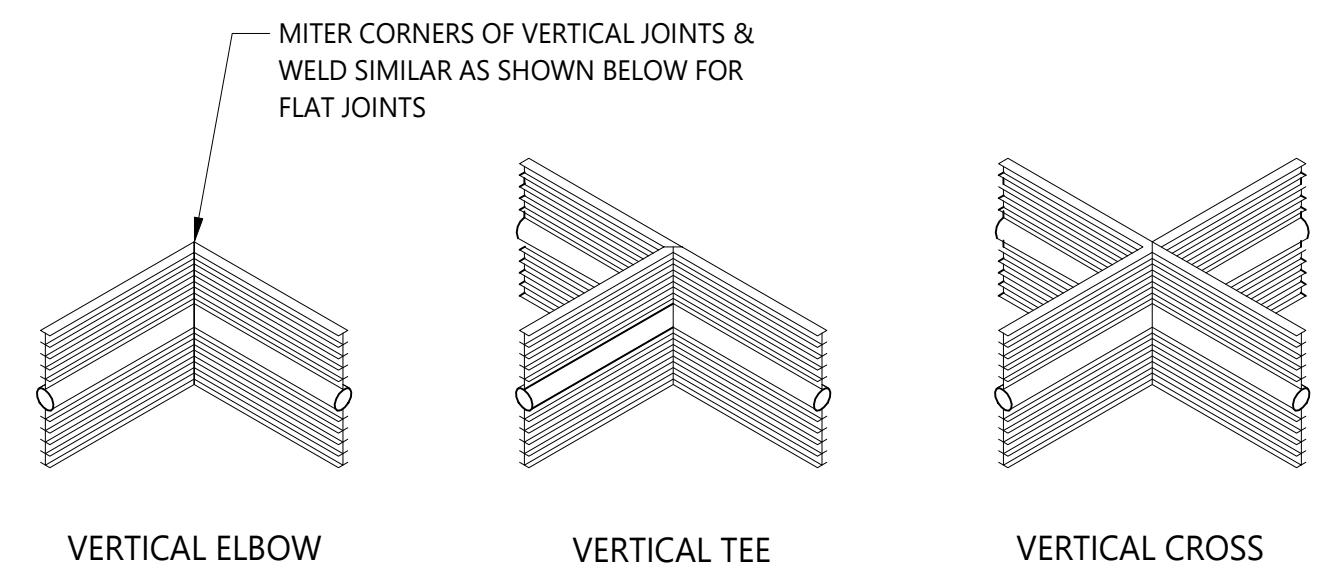

OUTLET VERTICAL WALL CONSTRUCTION JOINT
SCALE: 1 1/2" = 1'-0"

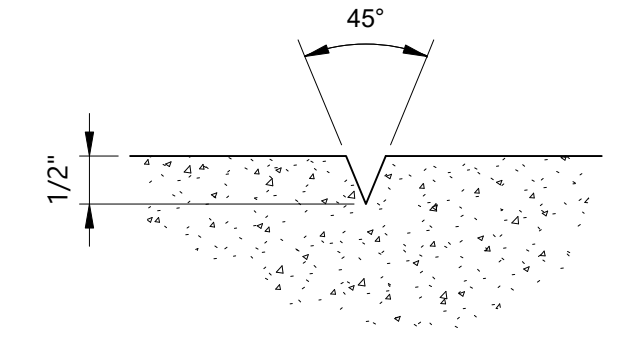

DETAIL 1 - V-JOINT
SCALE: 6" = 1'-0"

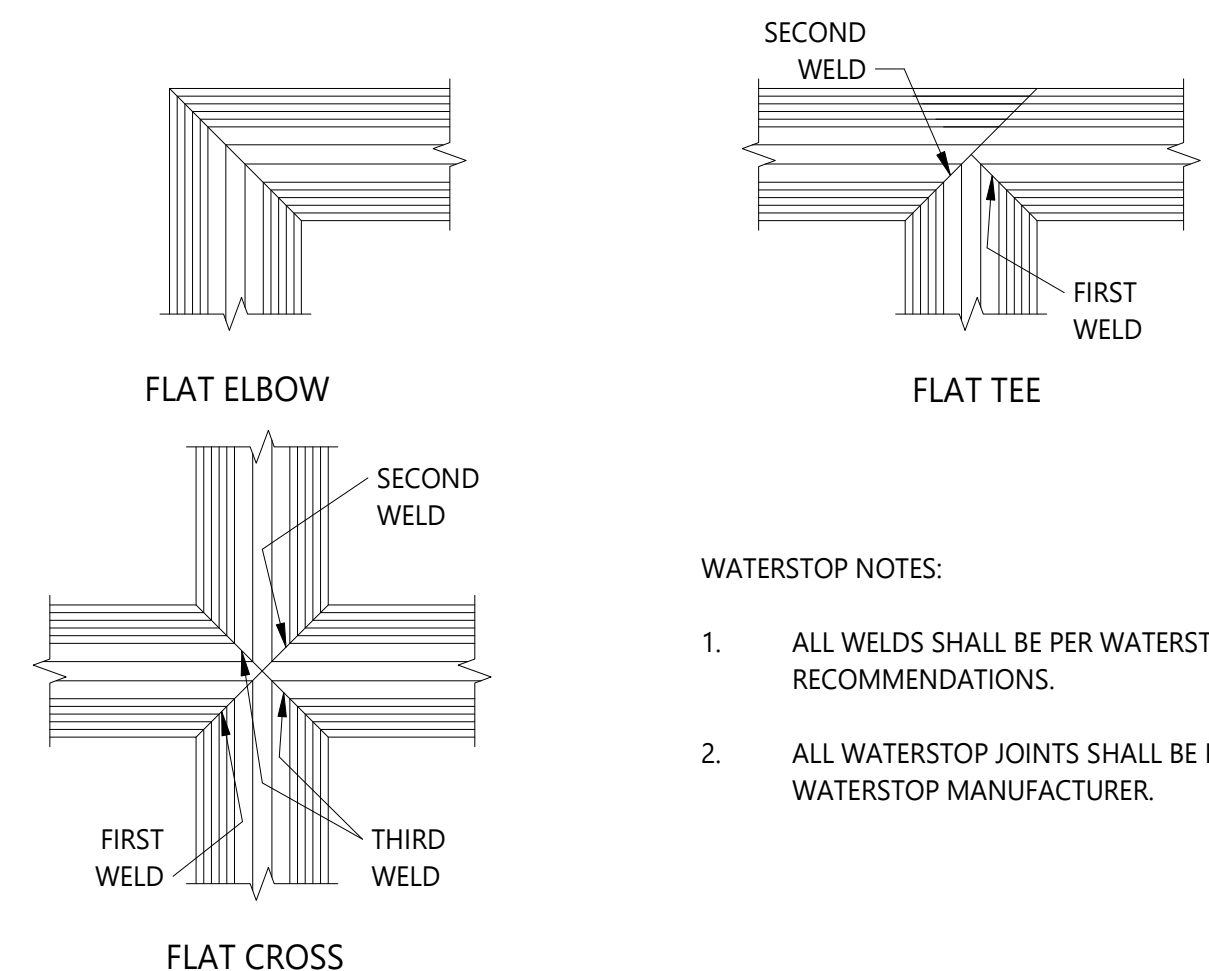

- WATERSTOP NOTES:**
1. ALL WELDS SHALL BE PER WATERSTOP MANUFACTURER'S RECOMMENDATIONS.
 2. ALL WATERSTOP JOINTS SHALL BE PRE-FABRICATED BY WATERSTOP MANUFACTURER.

WATERSTOP JOINT
DETAIL N.T.S.

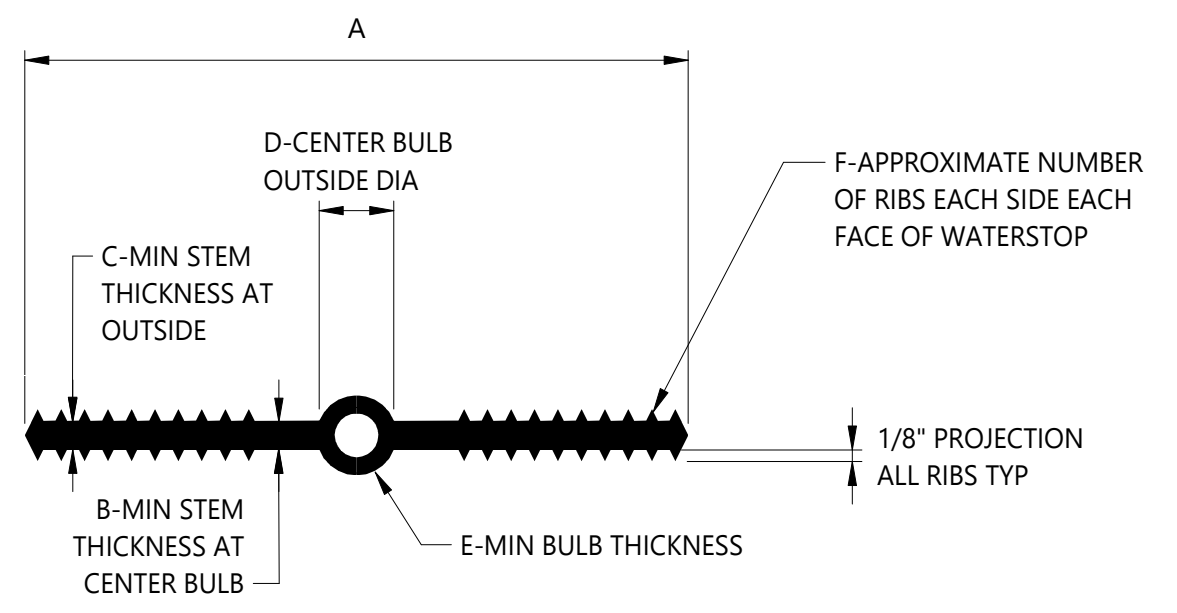

- WATERSTOP NOTES:**
- NON-ROUND CENTER BULBS SHALL HAVE A MINIMUM OUTSIDE DIMENSION OF 'D'.

SIZE	A	B	C	D	E	F
6"x3/8"	6"	3/8"	3/8"	1"	1/4"	8

PLASTIC WATERSTOP
NOT TO SCALE

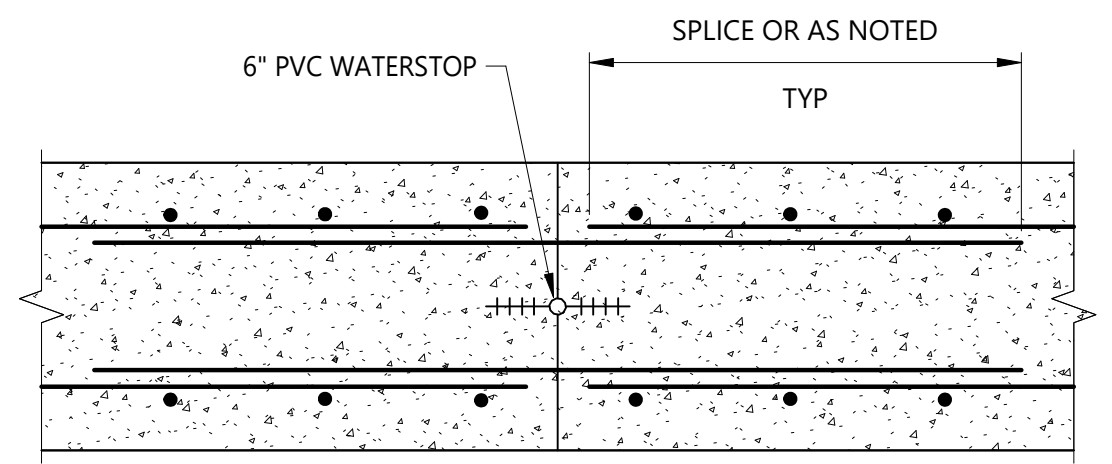

OUTLET SLAB CONSTRUCTION JOINT
NOT TO SCALE

- NOTES:**
1. SEE DRAWING S-100 AND S-101 FOR LEGEND, ABBREVIATIONS, AND GENERAL NOTES.

REV	REVISION DESCRIPTION	DATE	CHND	CHKD	APPR



CITY OF COLORADO SPRINGS
30 S. NEVADA AVE., SUITE 401
COLORADO SPRINGS, CO 80903
(719) 385-5980

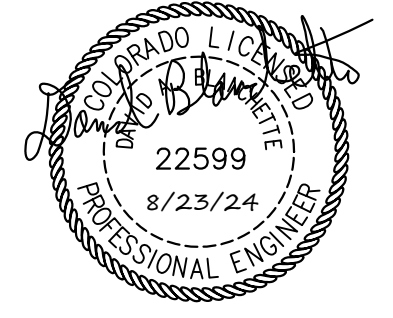

SAND CREEK DETENTION POND NO. 2

POND OUTLET STRUCTURE
CONCRETE STANDARD DETAILS

JOB NUMBER	65420975
DATE	8/23/24
DRAWING NO.	S-111
SHEET	44 of 51

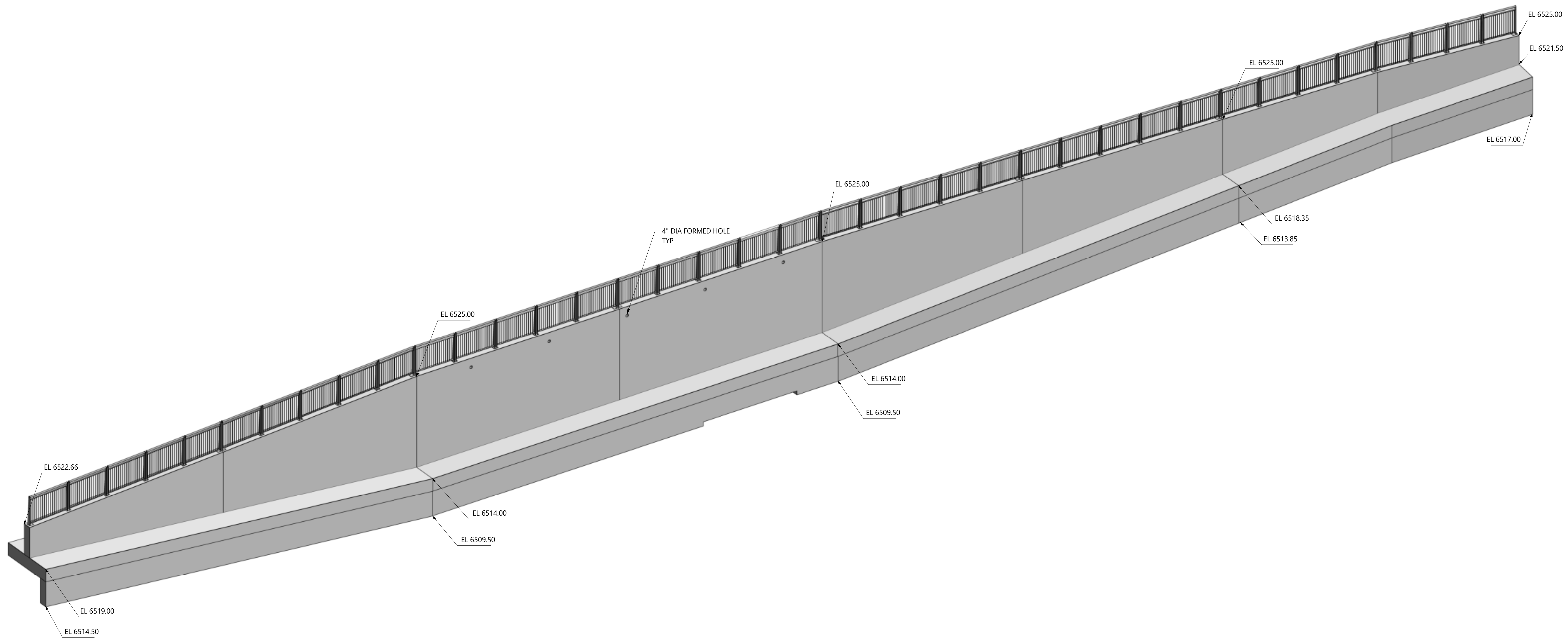

NOTES:

- SEE DRAWING S-100 AND S-101 FOR LEGEND, ABBREVIATIONS, AND GENERAL NOTES.

REV	REVISION DESCRIPTION	DATE	CHND	CHKD	APPR

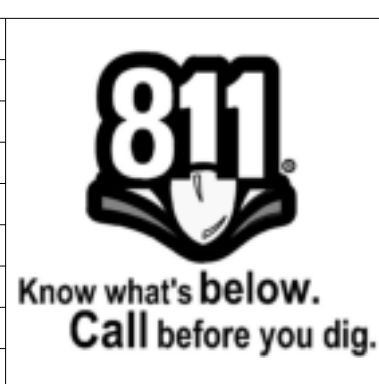

CITY OF COLORADO SPRINGS
 30 S. NEVADA AVE., SUITE 401
 COLORADO SPRINGS, CO 80903
 (719) 385-5980

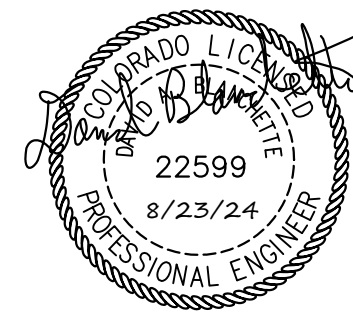

SAND CREEK DETENTION POND NO. 2

TUTT RETAINING WALL
 ISOMETRIC VIEW

JOB NUMBER	65420975
DATE	8/23/24
DRAWING NO.	S-112
SHEET	45 of 51

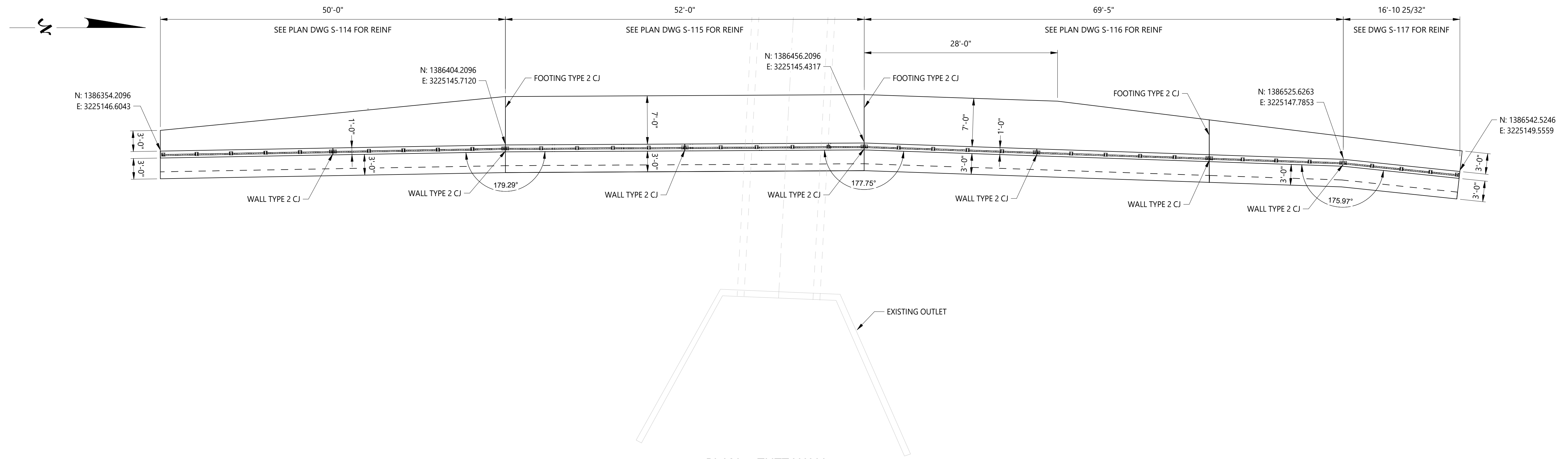

PLAN - TUTT WALL
SCALE: 1/8" = 1'-0"

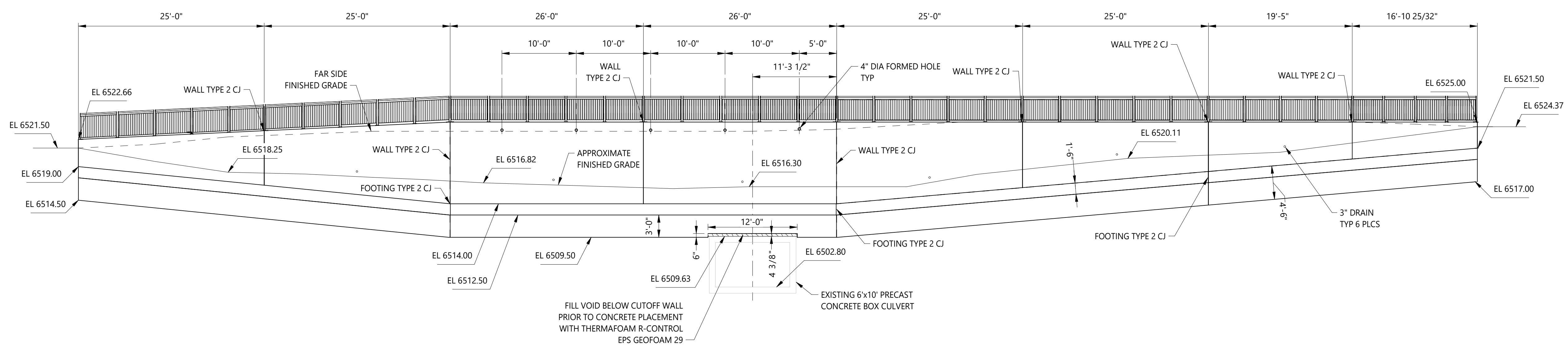

ELEVATION - TUTT WALL
SCALE: 1/8" = 1'-0"

- NOTES:
- SEE DRAWING S-100 AND S-101 FOR LEGEND, ABBREVIATIONS, AND GENERAL NOTES.
 - VERIFY LOCATION OF EXISTING BOX CULVERT AND UNDERGROUND UTILITIES INCLUDING DRAINS BEFORE DIGGING.

REV	REVISION DESCRIPTION	DATE	CHND	CHKD	APPR



CITY OF COLORADO SPRINGS
30 S. NEVADA AVE., SUITE 401
COLORADO SPRINGS, CO 80903
(719) 385-5980

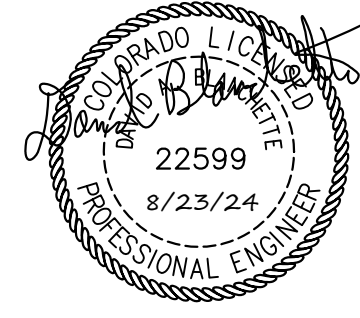

SAND CREEK DETENTION POND NO. 2
TUTT RETAINING WALL
OUTLINE PLAN AND ELEVATION

JOB NUMBER	65420975
DATE	8/23/24
DRAWING NO.	S-113
SHEET	46 of 51

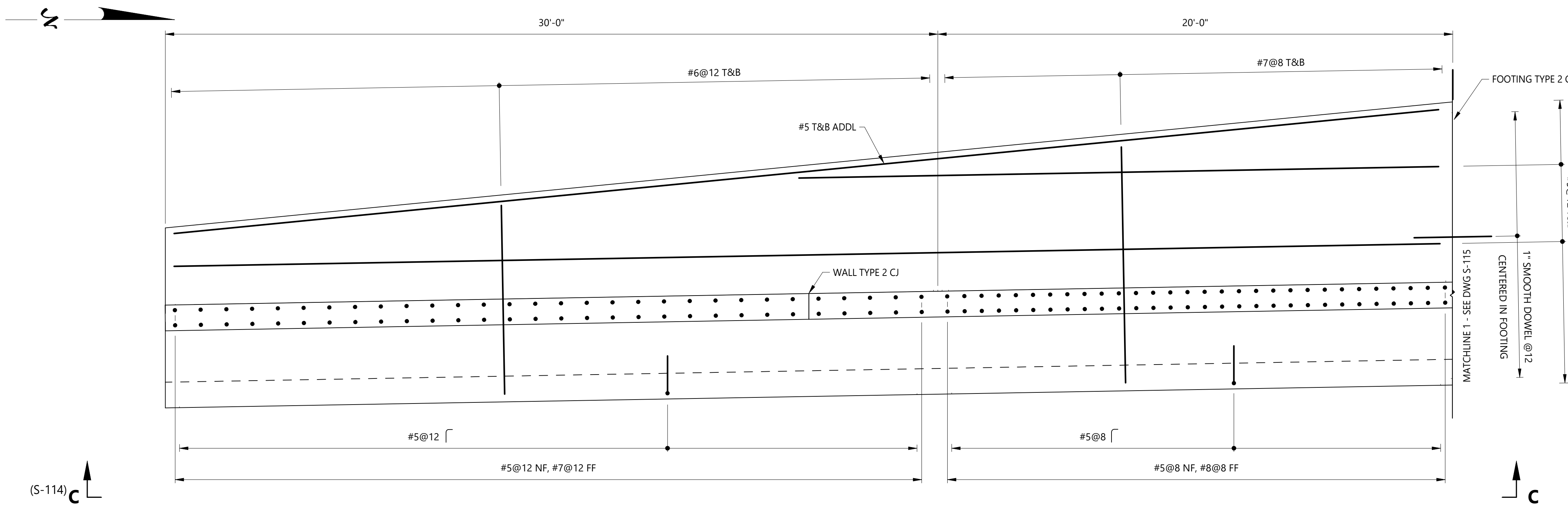

PARTIAL PLAN WALL
SCALE: 3/8" = 1'-0"

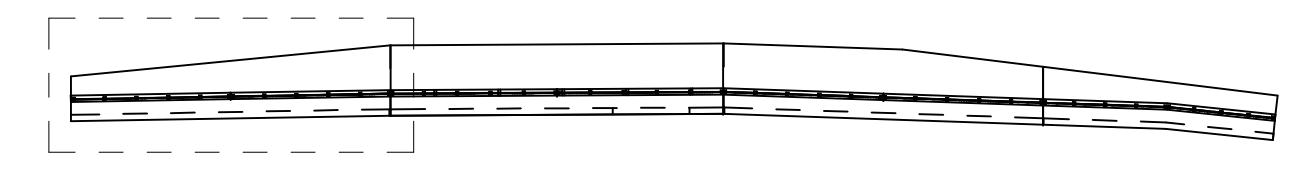

KEY PLAN
SCALE: 1" = 30'-0"

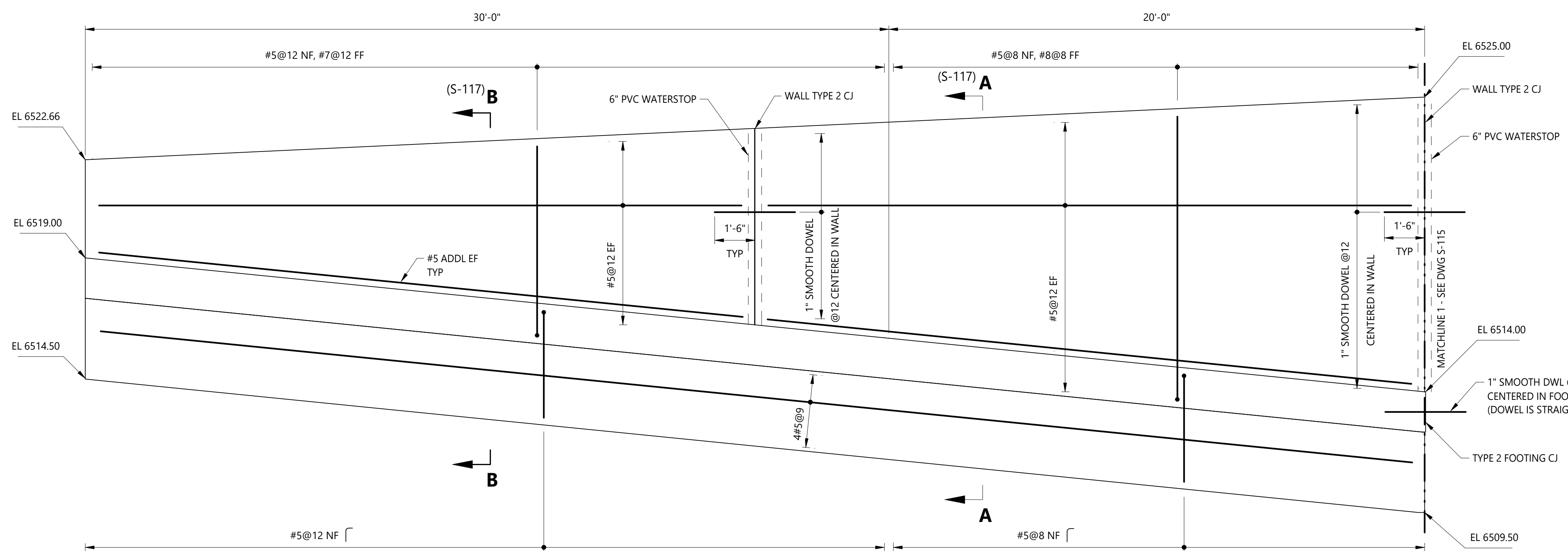

SECTION C - C (S-114)
SCALE: 3/8" = 1'-0"

- NOTES:**
- SEE DRAWING S-100 AND S-101 FOR LEGEND, ABBREVIATIONS, AND GENERAL NOTES.

REV	REVISION DESCRIPTION	DATE	CHND	CHKD	APPR



CITY OF COLORADO SPRINGS
30 S. NEVADA AVE., SUITE 401
COLORADO SPRINGS, CO 80903
(719) 385-5980

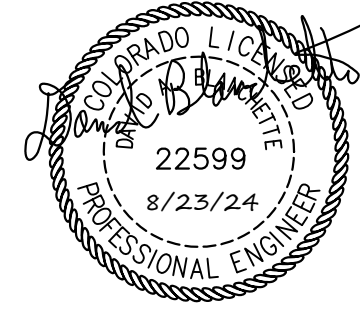

SAND CREEK DETENTION POND NO. 2

TUTT RETAINING WALL
REINFORCEMENT PLAN AND SECTION

JOB NUMBER	65420975
DATE	8/23/24
DRAWING NO.	S-114
SHEET	47 of 51

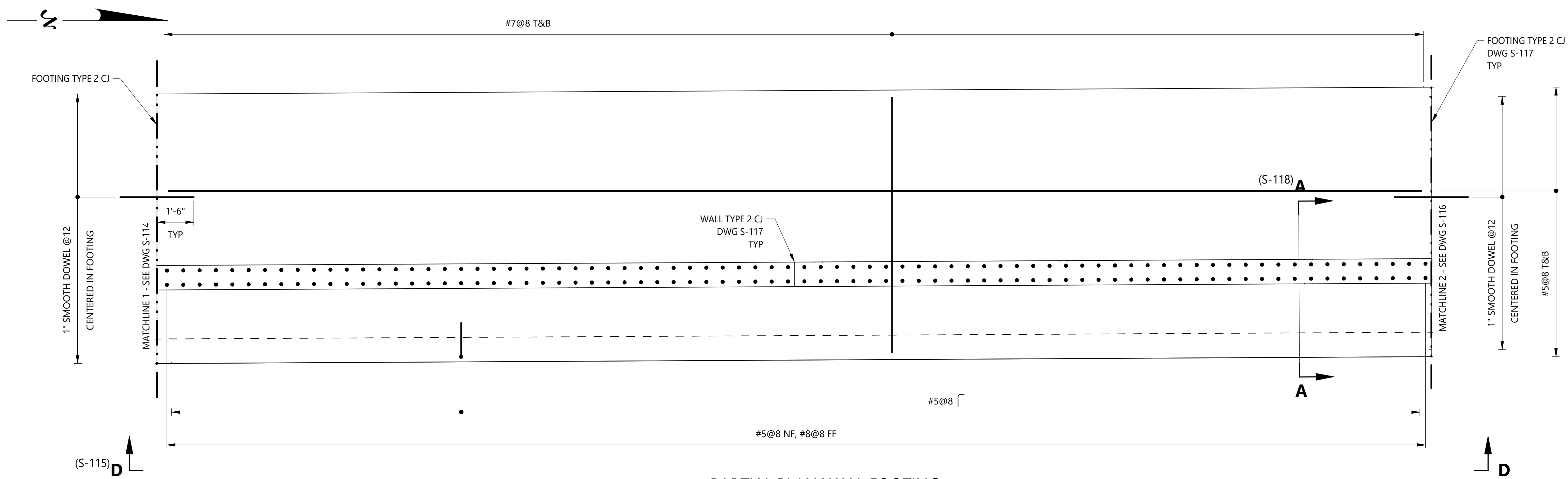

PARTIAL PLAN WALL FOOTING
SCALE: 3/8" = 1'-0"

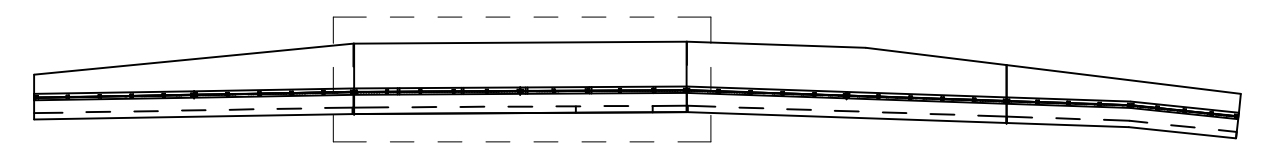

KEY PLAN
SCALE: 1" = 30'-0"

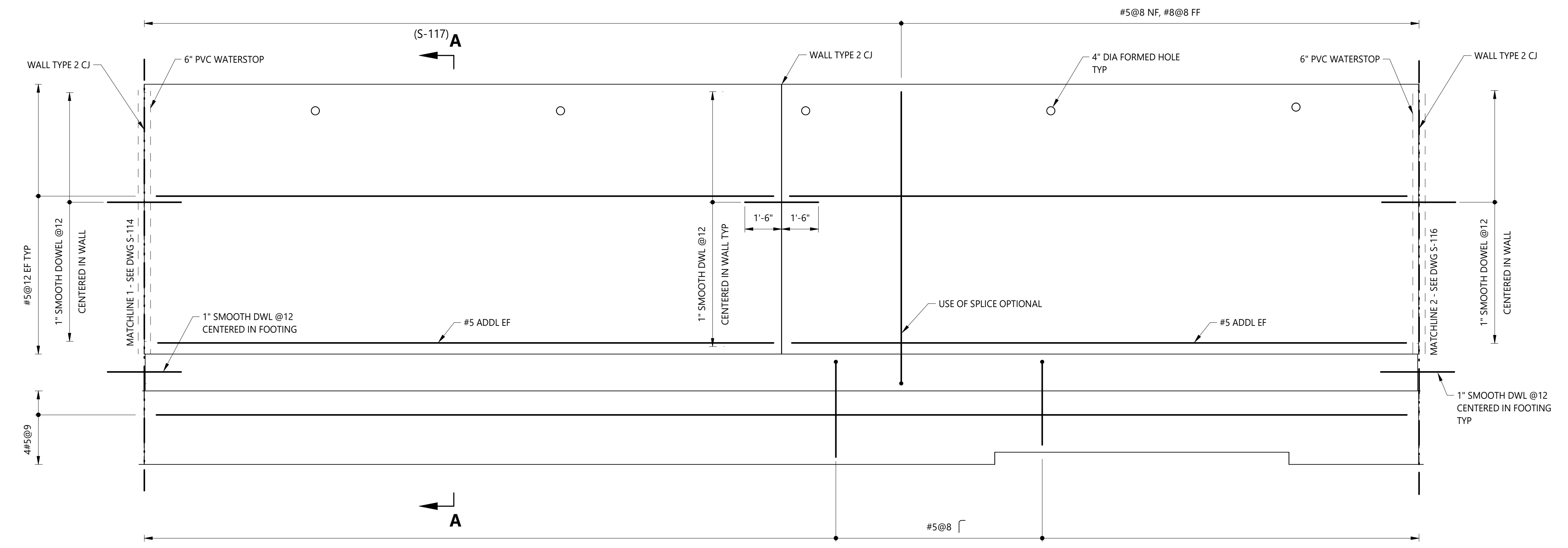

SECTION D - D (S-115)
SCALE: 3/8" = 1'-0"

REV	REVISION DESCRIPTION	DATE	CHND	CHKD	APPR



CITY OF COLORADO SPRINGS
30 S. NEVADA AVE., SUITE 401
COLORADO SPRINGS, CO 80903
(719) 385-5980

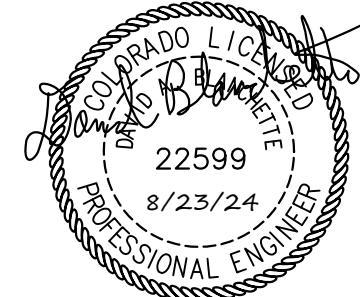

SAND CREEK DETENTION POND NO. 2

TUTT RETAINING WALL
REINFORCEMENT PLAN AND SECTION

JOB NUMBER	65420975
DATE	8/23/24
DRAWING NO.	S-115
SHEET	48 of 51

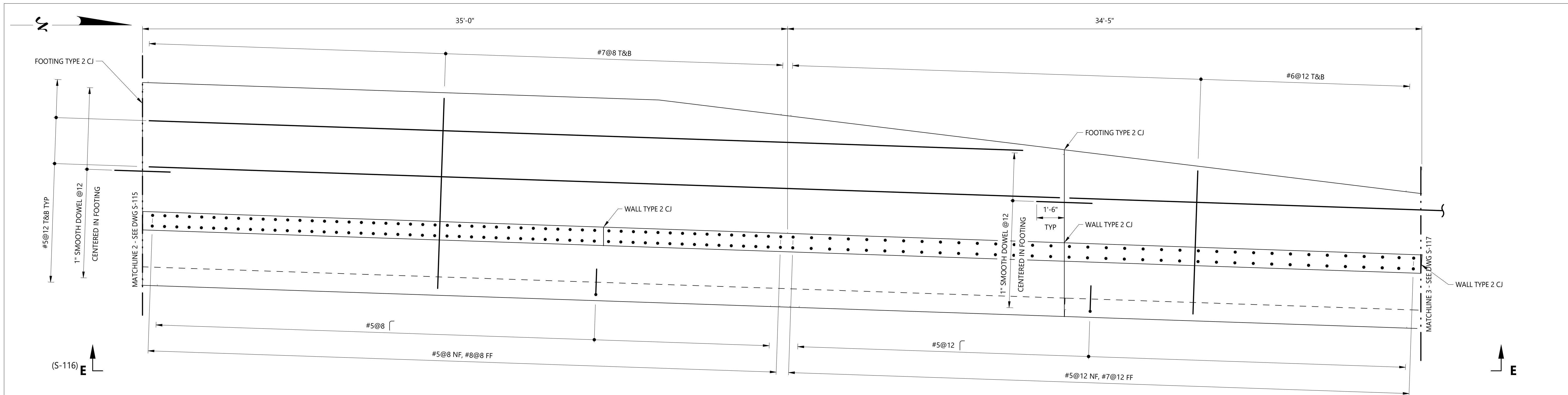

PARTIAL PLAN WALL FOOTING
SCALE: 3/8" = 1'-0"

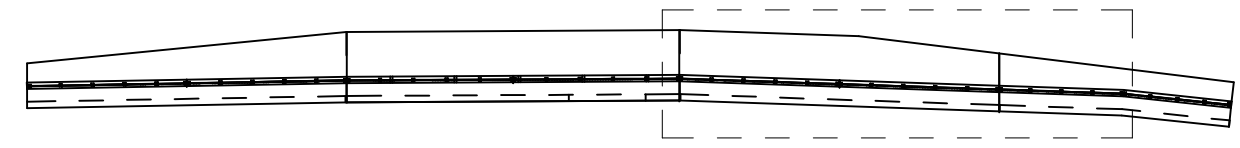

KEY PLAN
SCALE: 1" = 30'-0"

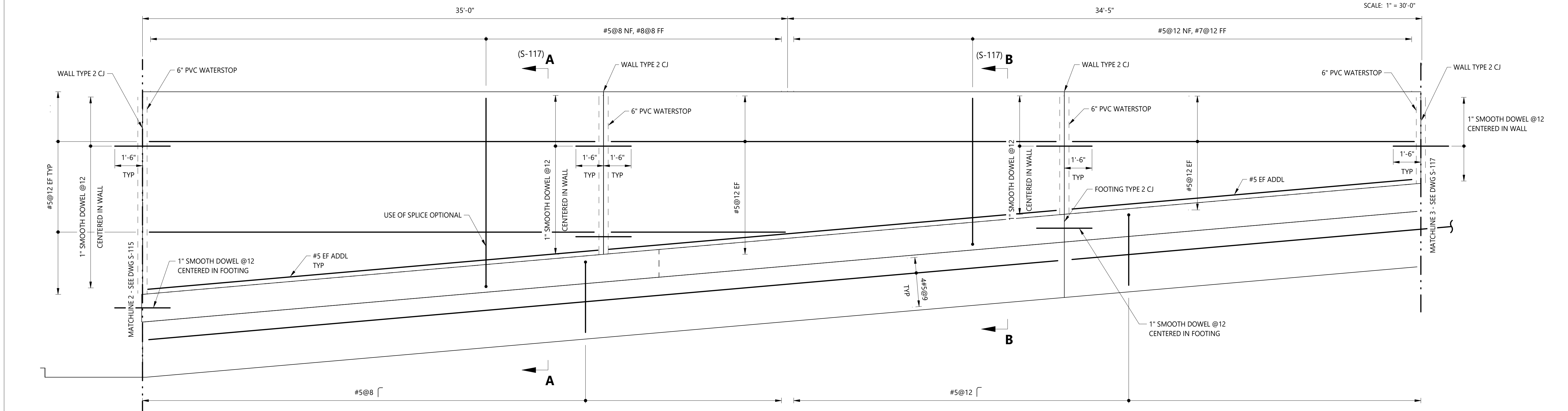

SECTION E - E (S-116)
SCALE: 3/8" = 1'-0"

REV	REVISION DESCRIPTION	DATE	CHND	CHKD	APPR



CITY OF COLORADO SPRINGS
30 S. NEVADA AVE., SUITE 401
COLORADO SPRINGS, CO 80903
(719) 385-5980

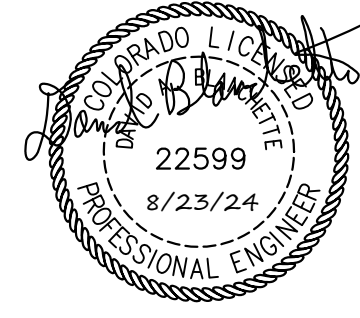

SAND CREEK DETENTION POND NO. 2
TUTT RETAINING WALL
REINFORCEMENT PLAN AND SECTION

JOB NUMBER	65420975
DATE	8/23/24
DRAWING NO.	S-116
SHEET	49 of 51

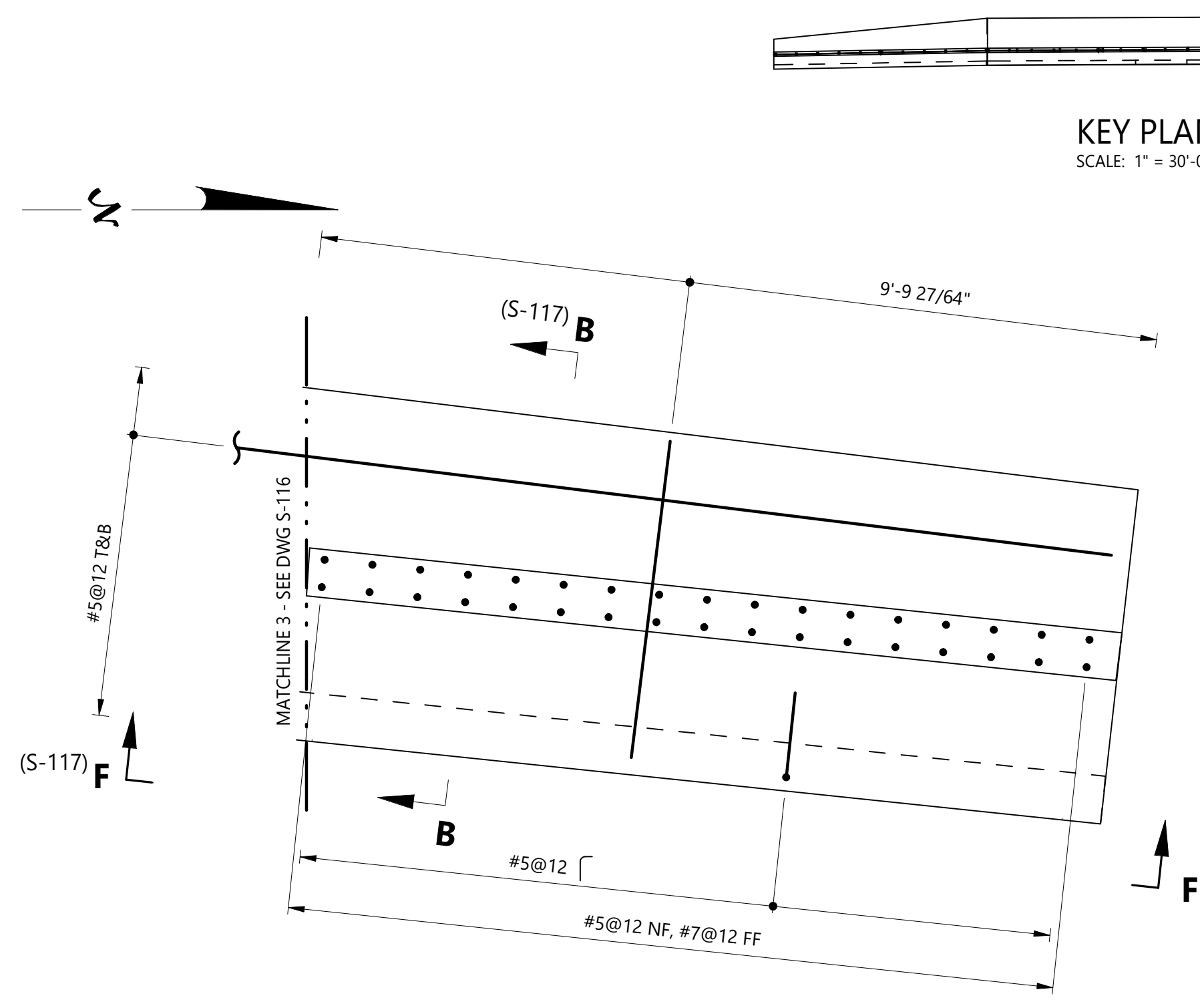

PARTIAL PLAN WALL FOOTING
SCALE: 3/8" = 1'-0"

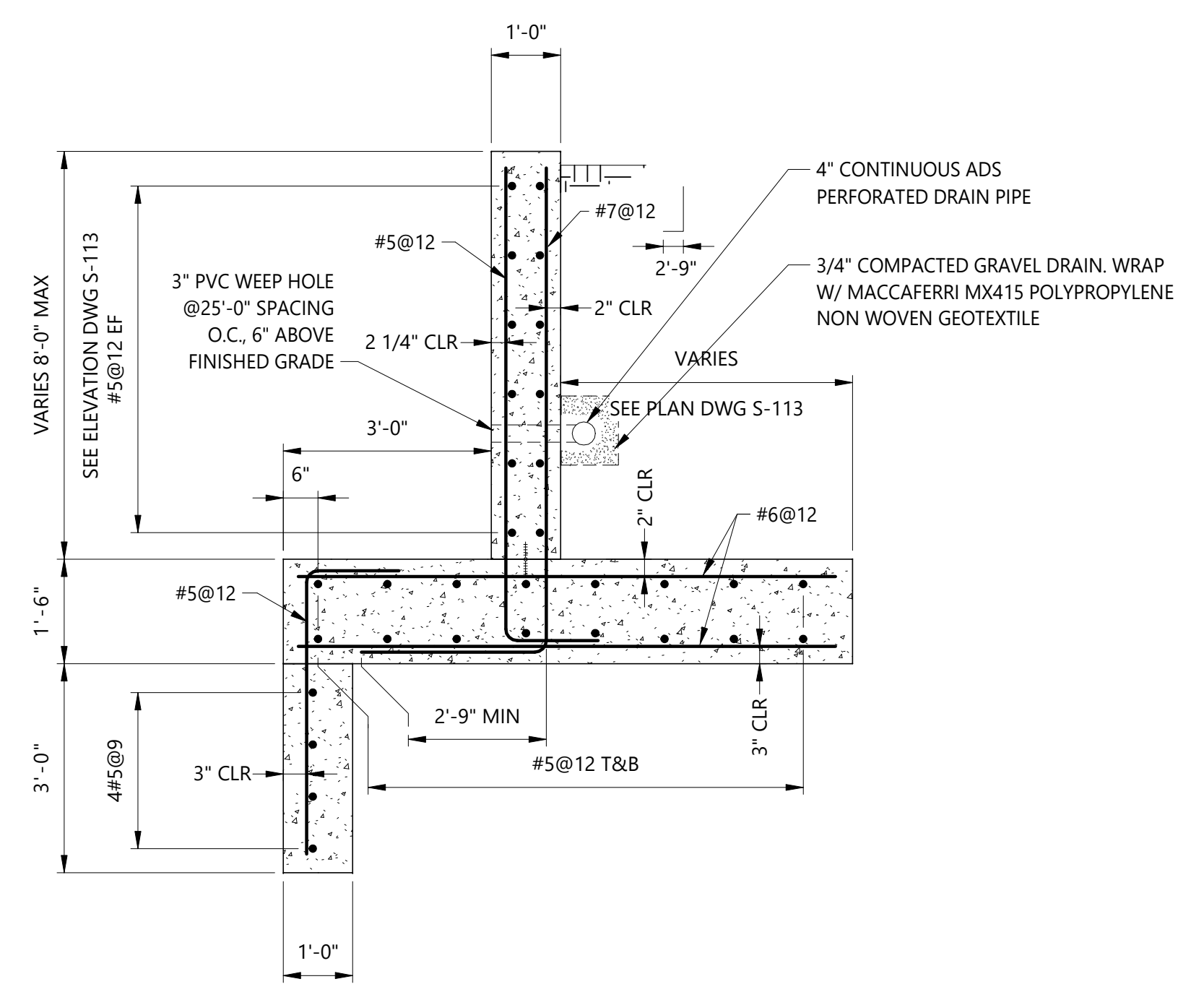

SECTION B-B (S-114, 116, 117)
SCALE: 1/2" = 1'-0"

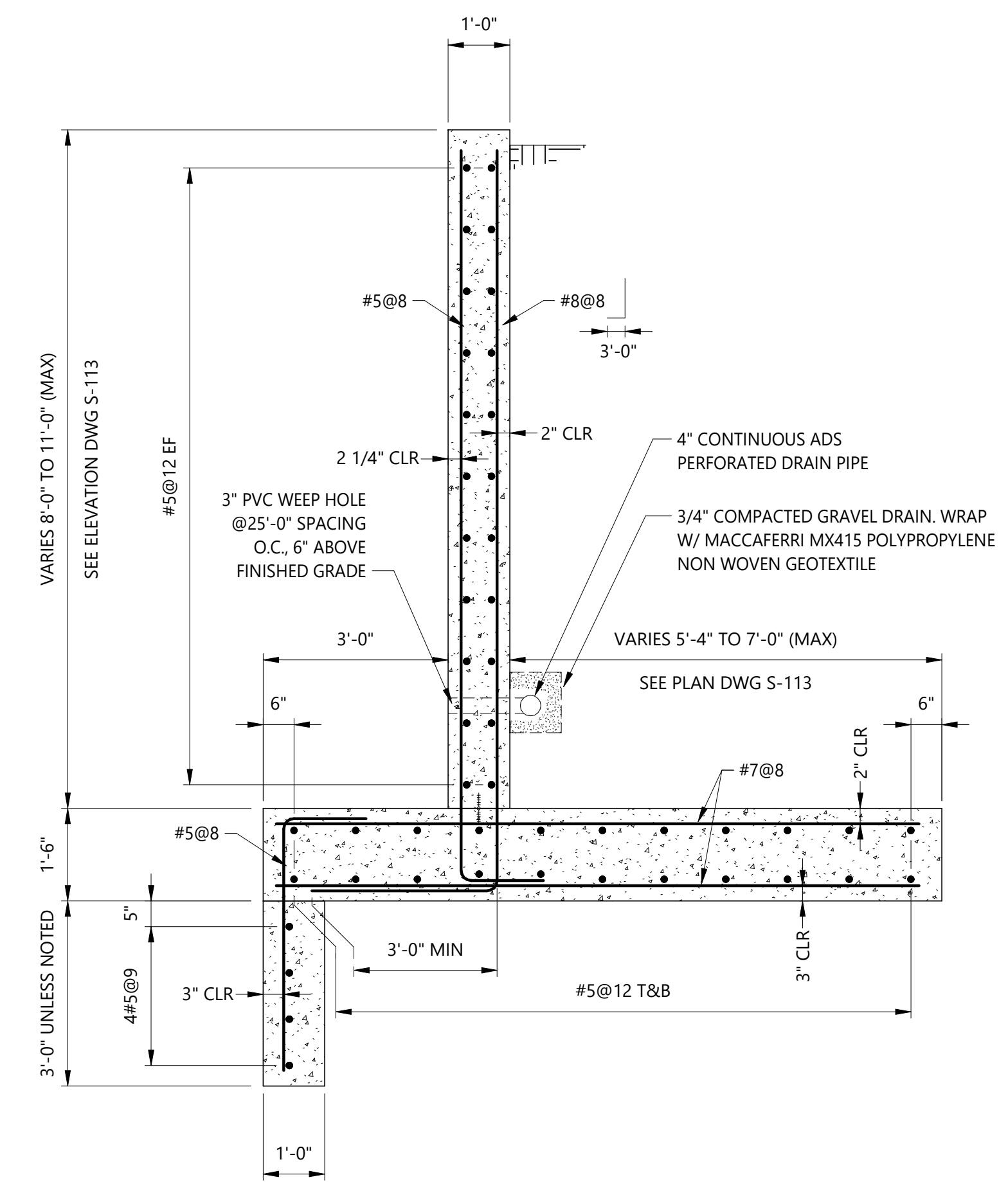

SECTION A-A (S-114, 115, 116)
SCALE: 1/2" = 1'-0"

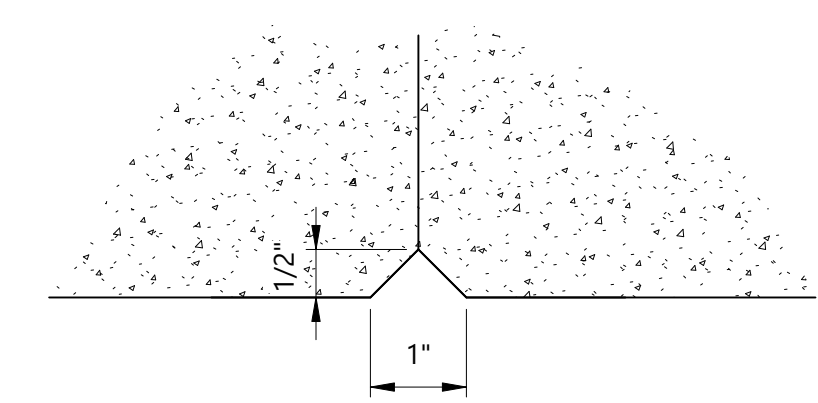

DETAIL 2 - VEE GROOVE
SCALE: 6" = 1'-0"

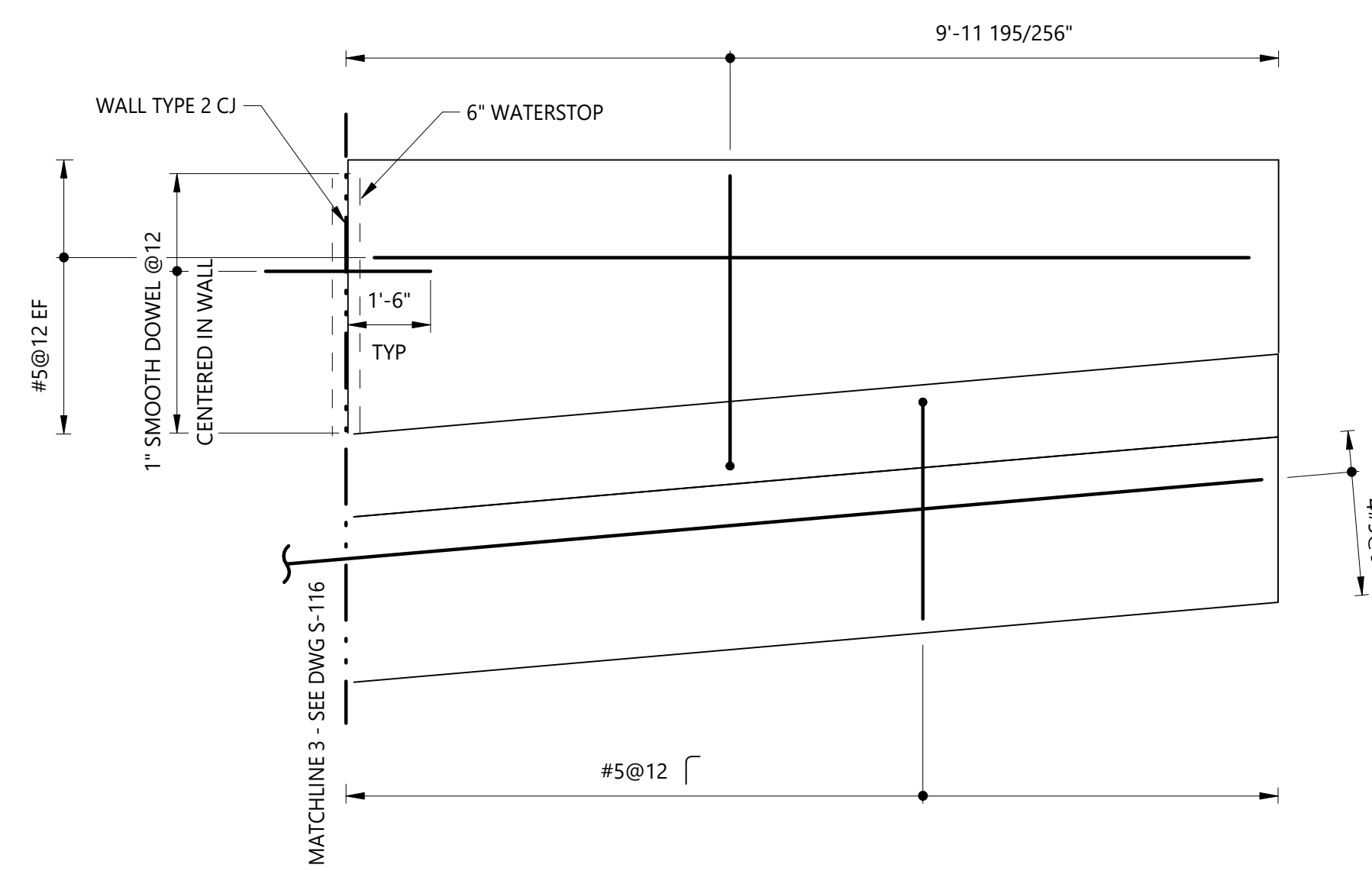

SECTION F - F (S-117)
SCALE: 3/8" = 1'-0"

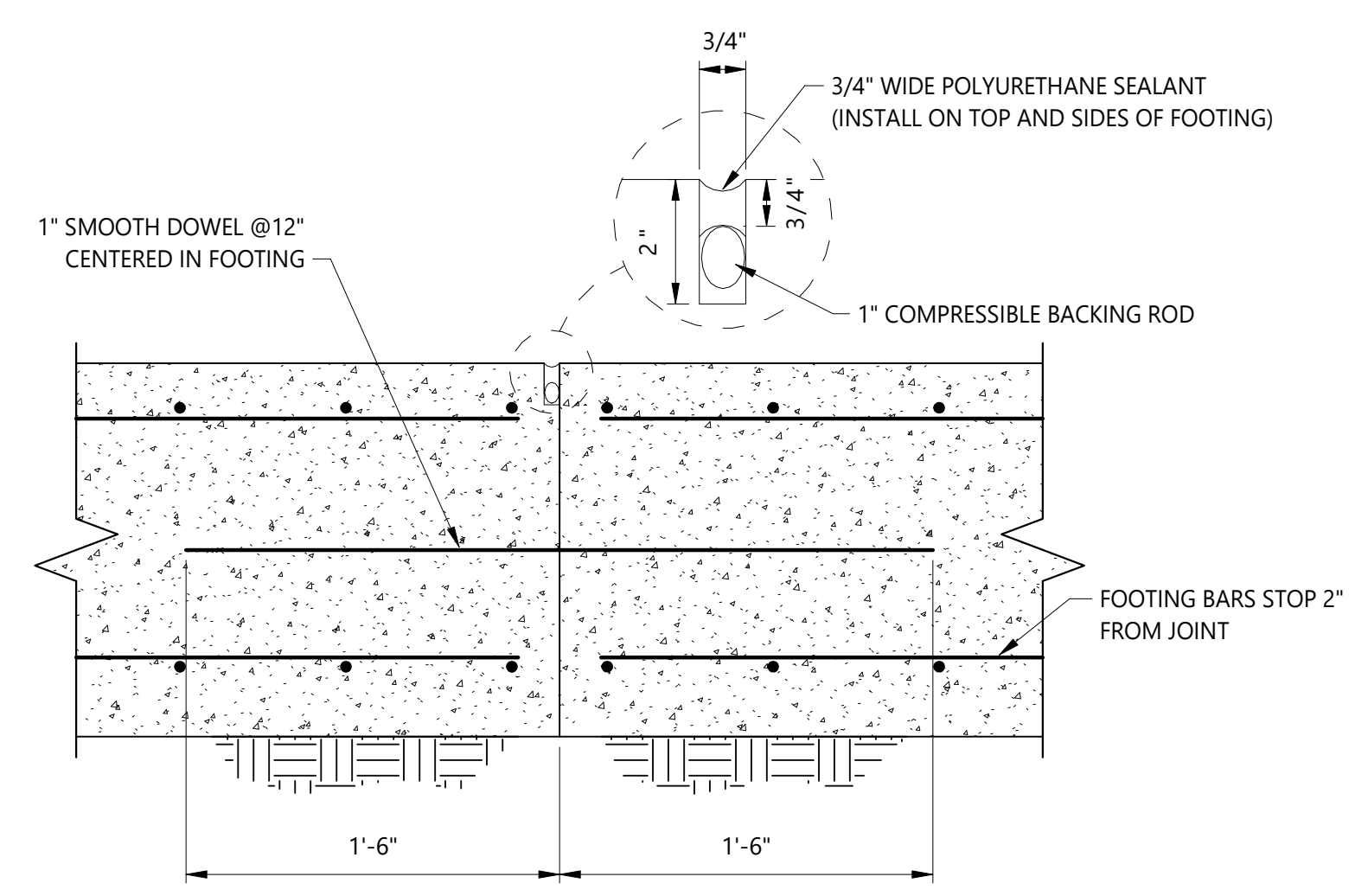

TYPE 2 FOOTING CONSTRUCTION JOINT
SCALE: 1 1/2" = 1'-0"

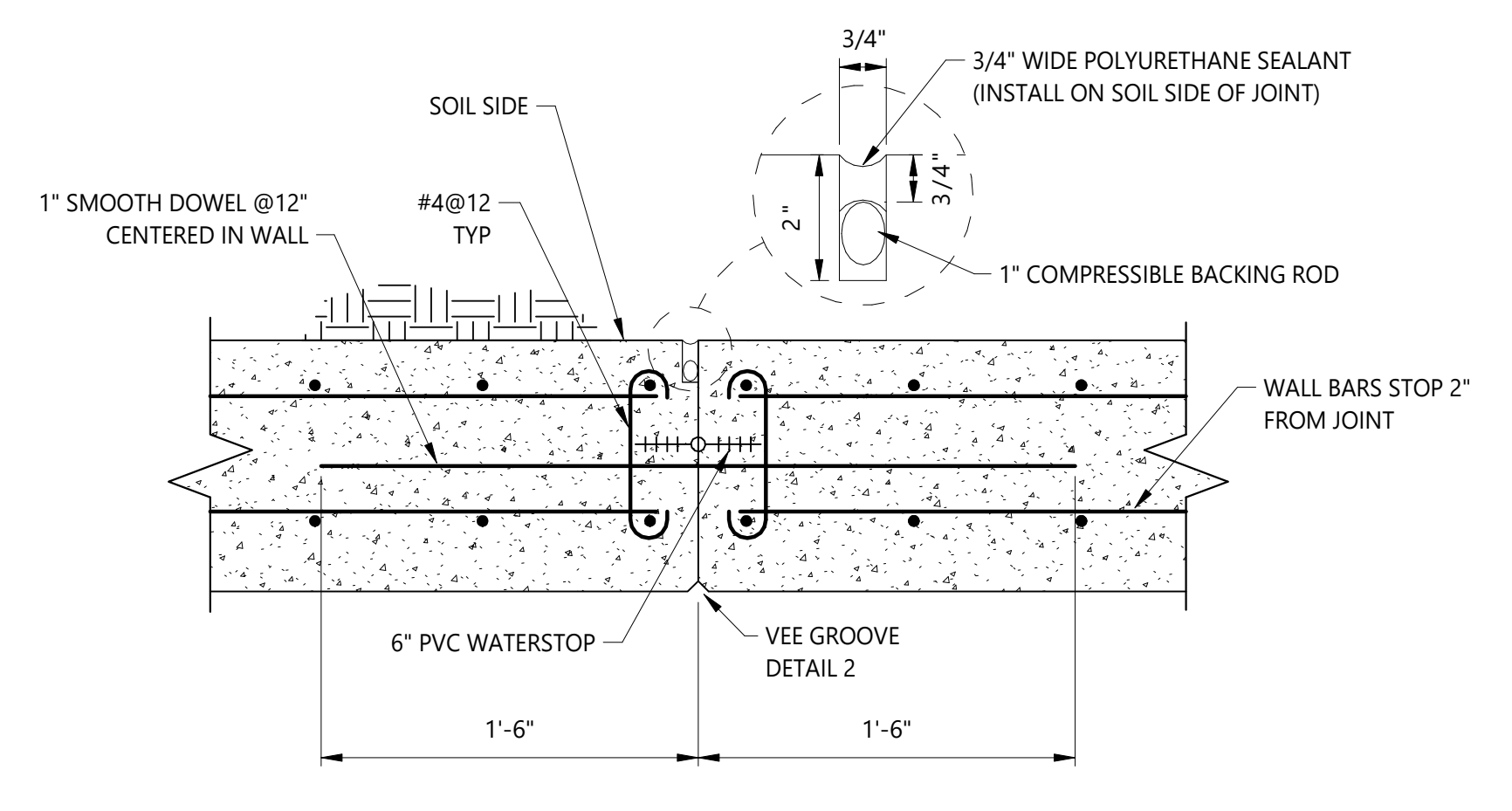

TYPE 2 VERTICAL WALL CONSTRUCTION JOINT
SCALE: 1 1/2" = 1'-0"

REV	REVISION DESCRIPTION	DATE	CHND	CHKD	APPR



CITY OF COLORADO SPRINGS
30 S. NEVADA AVE., SUITE 401
COLORADO SPRINGS, CO 80903
(719) 385-5980

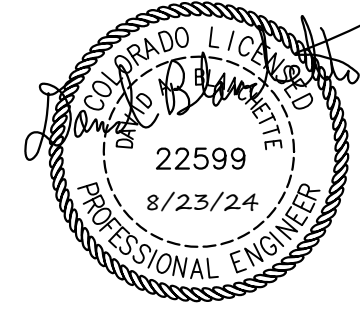
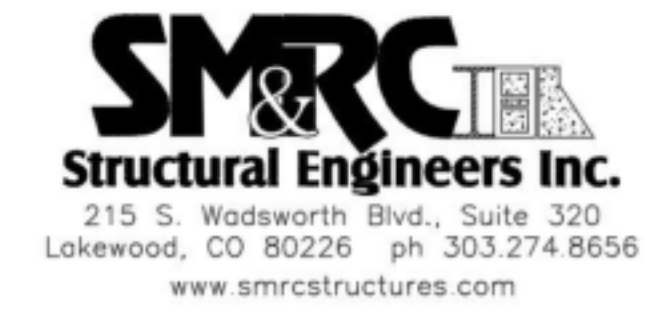

SAND CREEK DETENTION POND NO. 2
TUTT RETAINING WALL
REINFORCEMENT PLAN AND SECTIONS

JOB NUMBER	65420975
DATE	8/23/24
DRAWING NO.	S-117
SHEET	50 of 51

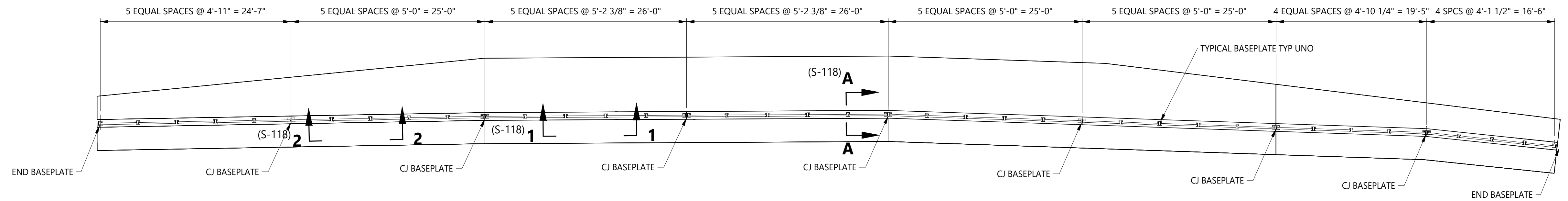

TUTT WALL BASEPLATE PLAN
SCALE: 1/8" = 1'-0"

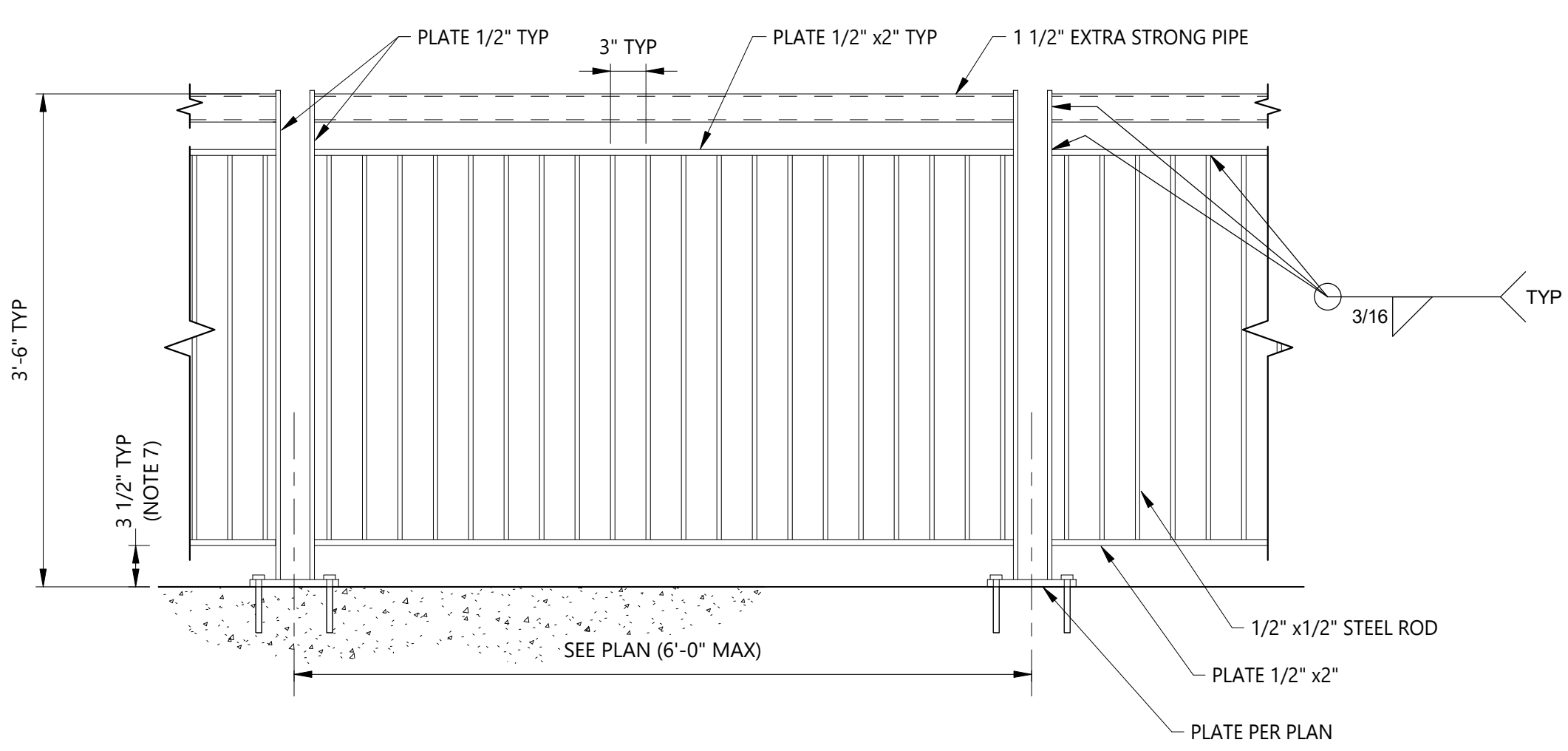

DETAIL 1 TYPICAL HORIZONTAL HANDRAIL
SCALE: 1" = 1'-0"

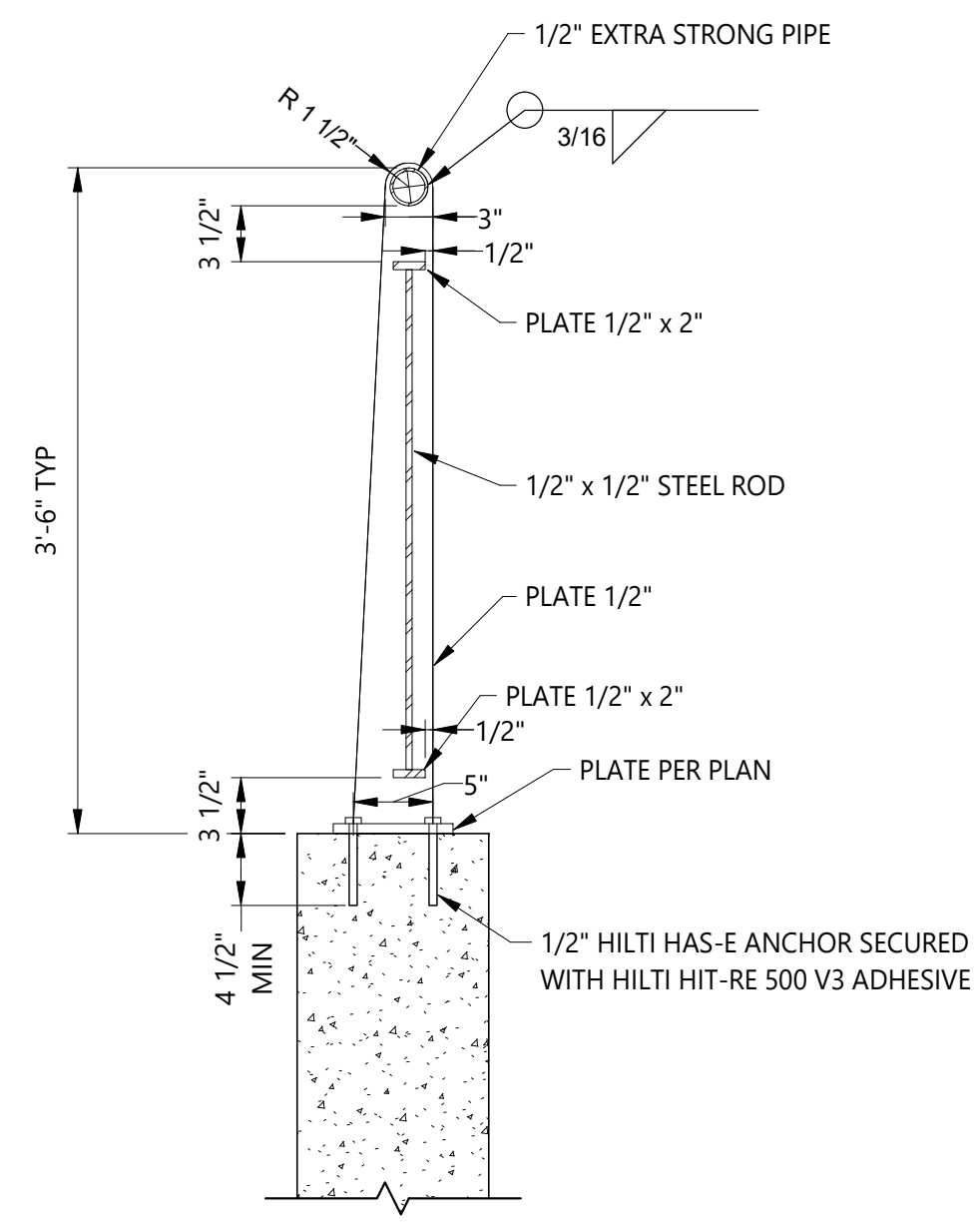

SECTION A - A (S-115)
SCALE: 1" = 1'-0"

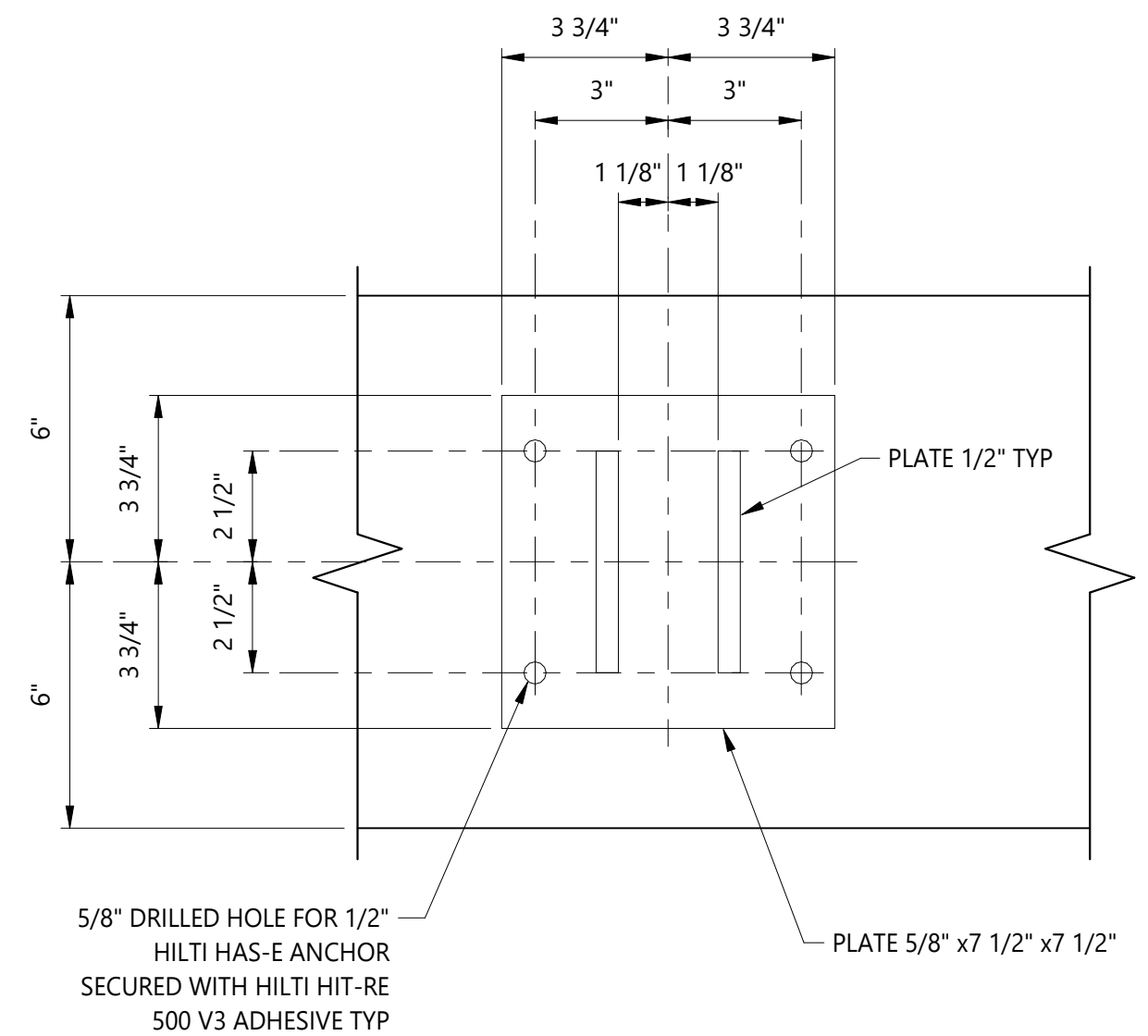

TYPICAL BASEPLATE
SCALE: 3" = 1'-0"

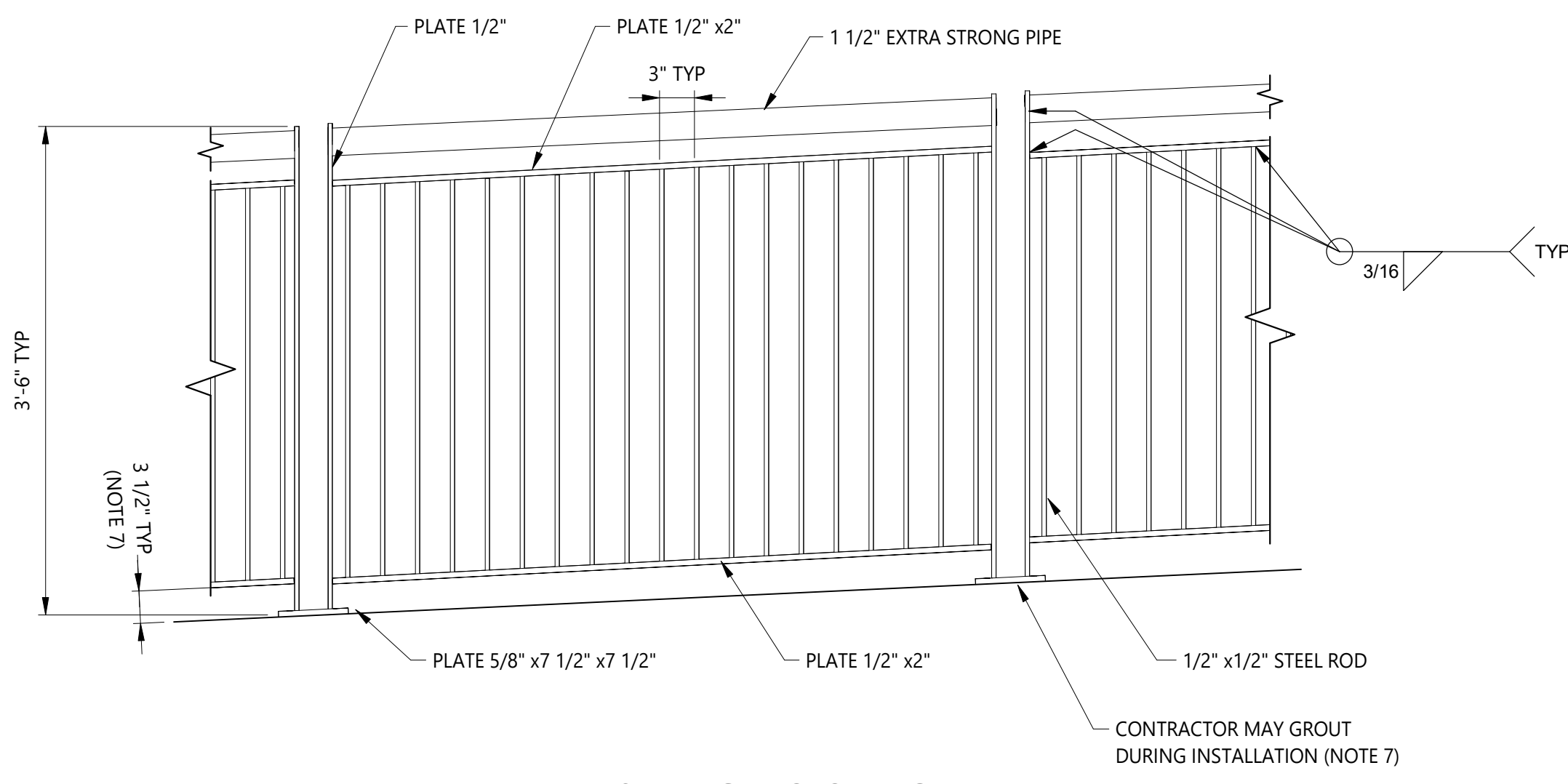

DETAIL 2 TYPICAL SLOPING HANDRAIL
SCALE: 1" = 1'-0"

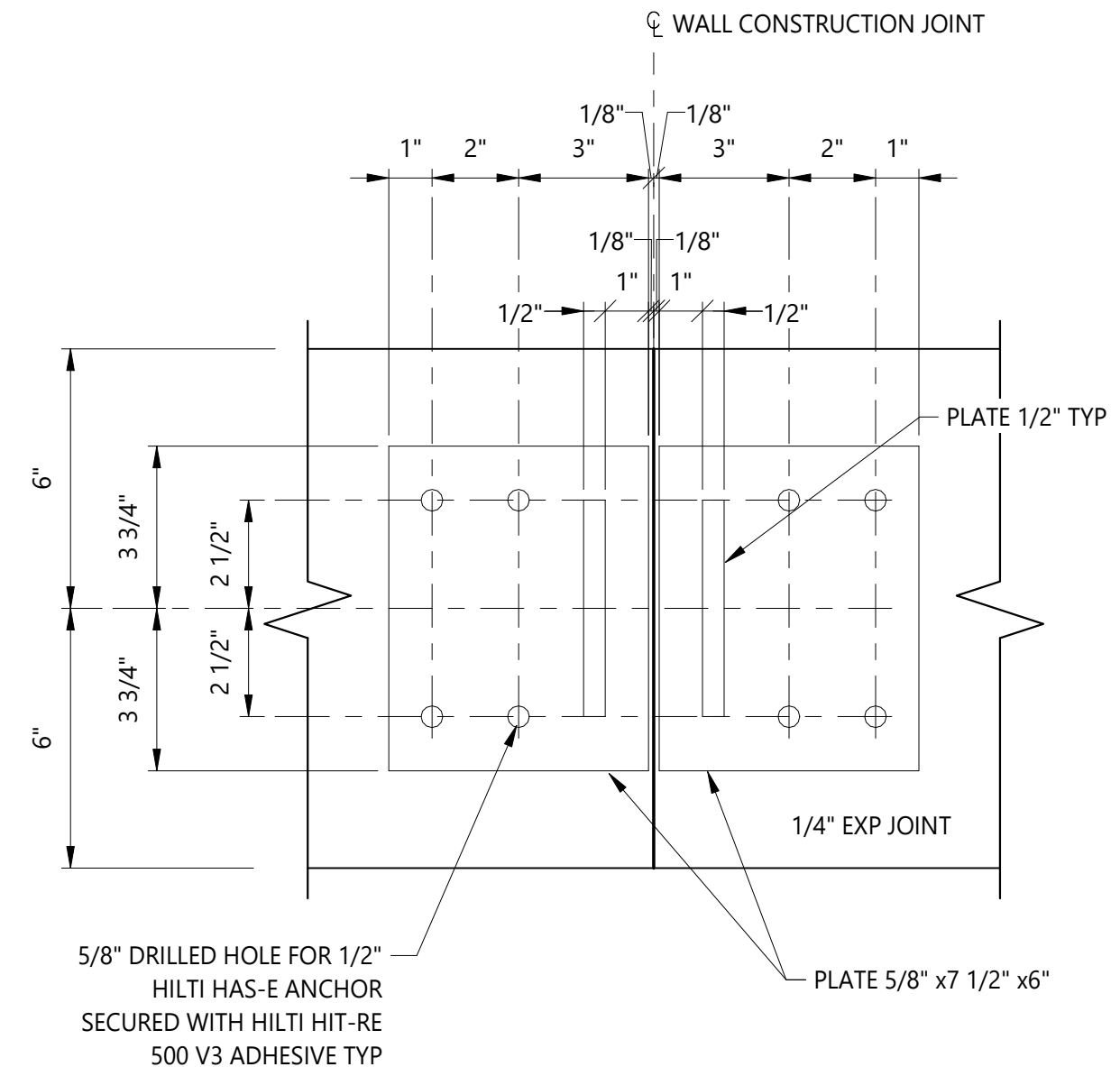

CJ BASEPLATE
SCALE: 3" = 1'-0"

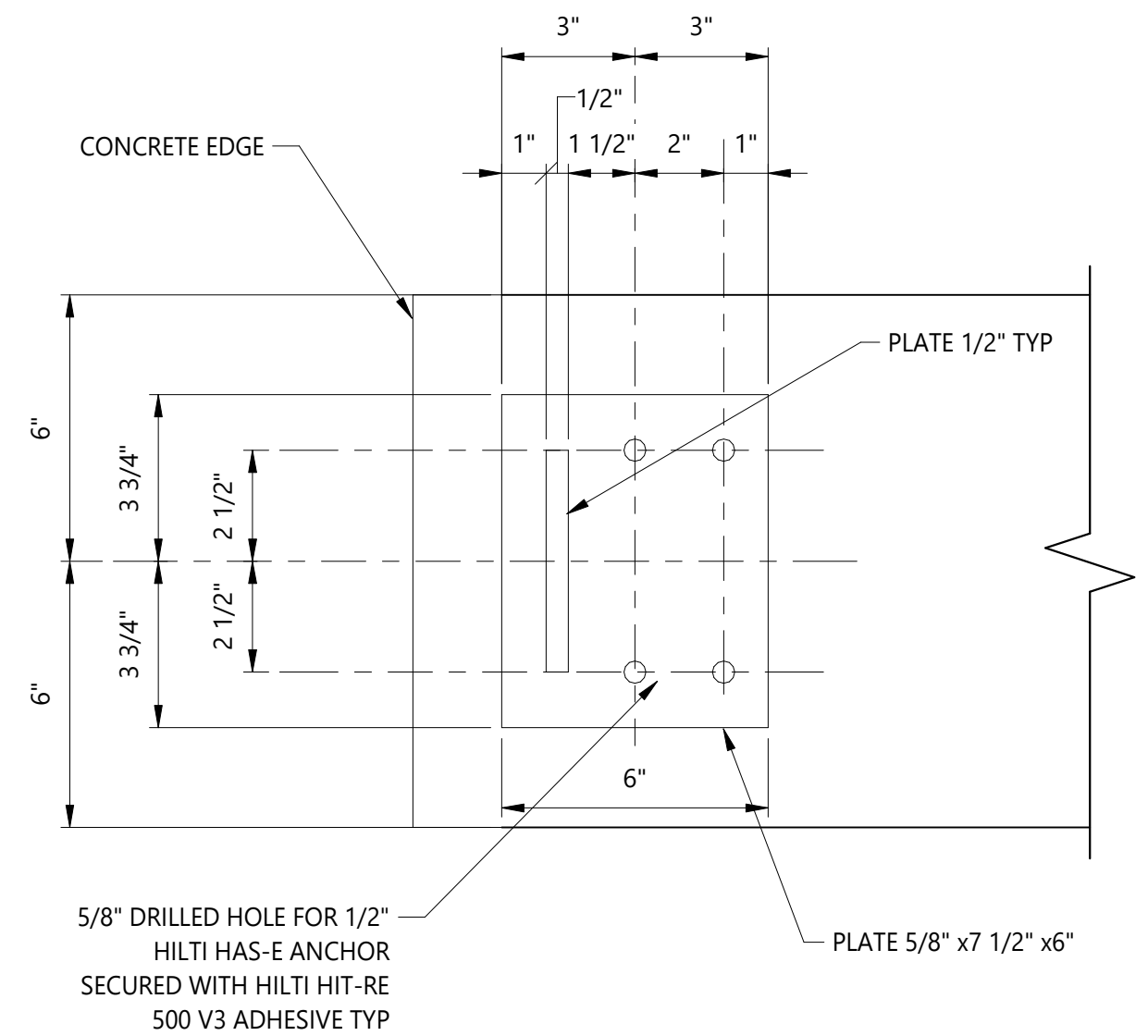

END BASEPLATE
SCALE: 3" = 1'-0"

- TYPICAL HANDRAIL NOTES:**
1. ALL RAILING COMPONENTS TO BE PAINTED AS DIRECTED BY ARCHITECT.
 2. CONTRACTOR TO PROVIDE SHOP DRAWINGS INCLUDING WELD INFORMATION.
 3. CONTRACTOR SHALL FIELD MEASURE HEAD WALLS AND WING WALLS TO ENSURE PROPER FIT OF RAILING.
 4. POSTS AND PICKETS SHALL BE PLUMB ON RAILING SECTIONS.
 5. INSTALL SINGLE POST AT END OF RAILING.
 6. HANDRAIL POST SPACING AT TUTT WALL SHALL BE EQUIDISTANCE BETWEEN CONSTRUCTION JOINTS AND TO BE FIELD VERIFIED.
 7. RAIL GAP TO TOP OF CONCRETE TO BE 4" MAX.

REV	REVISION DESCRIPTION	DATE	CHND	CHKD	APPR



CITY OF COLORADO SPRINGS
30 S. NEVADA AVE., SUITE 401
COLORADO SPRINGS, CO 80903
(719) 385-5980

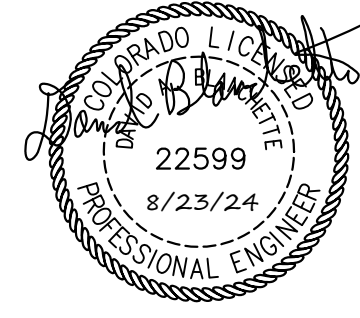

SAND CREEK DETENTION POND NO. 2

TUTT RETAINING WALL
HANDRAIL STEEL DETAILS

JOB NUMBER	65420975
DATE	8/23/24
DRAWING NO.	S-118
SHEET	51 of 51



SCHEDULE H – GEC DRAWINGS

Will follow this page.

THE CITY OF COLORADO SPRINGS, COLORADO, IS AN INSTRUMENT OF SERVICE PROVIDED BY MERRICK AND COMPANY, INC. A REGISTERED PROFESSIONAL ENGINEER HAS REVIEWED THIS PLAN AND HAS DETERMINED THAT IT IS IN ACCORDANCE WITH THE CITY OF COLORADO SPRINGS, COLORADO, INSTRUMENT OF SERVICE. MERRICK AND COMPANY, INC. IS NOT PROVIDING ANY GUARANTEE OR WARRANTY FOR THE PROJECT. IT IS THE USER'S RESPONSIBILITY TO OBTAIN ALL NECESSARY PERMITS AND APPROVALS FROM THE APPROPRIATE AGENCIES. THE USER SHALL BE RESPONSIBLE FOR OBTAINING ALL NECESSARY PERMITS AND APPROVALS FROM THE APPROPRIATE AGENCIES. THE USER SHALL BE RESPONSIBLE FOR OBTAINING ALL NECESSARY PERMITS AND APPROVALS FROM THE APPROPRIATE AGENCIES.

File Location: Q:\Denver - North\Projects\City of Colorado Springs\Sand Creek Pond No. 2\CAD\CCS\0975 - EROSION-CONTROL-COVER.dwg Plot Date: 8/27/2024 11:27 AM Last Saved By: TIM.MCMILLEN

ENGINEER'S STATEMENT

"THIS GRADING AND EROSION CONTROL PLAN WAS PREPARED UNDER MY DIRECTION AND SUPERVISION AND IS CORRECT TO THE BEST OF MY KNOWLEDGE AND BELIEF. IF SUCH WORK IS PERFORMED IN ACCORDANCE WITH THE GRADING AND EROSION CONTROL PLAN, THE WORK WILL NOT BECOME A HAZARD TO LIFE AND LIMB, ENDANGER PROPERTY, OR ADVERSELY AFFECT THE SAFETY, USE, OR STABILITY OF A PUBLIC WAY, DRAINAGE CHANNEL, OR OTHER PROPERTY."

PRINTED NAME: WALTER C. PENNINGTON DATE: 9/04/2024

PHONE NUMBER: 720-330-3210

SEAL:



CONTRACTOR'S STATEMENT

"I WILL COMPLY WITH THE REQUIREMENTS OF THE GRADING AND EROSION CONTROL PLAN INCLUDING CONSTRUCTION CONTROL MEASURE INSPECTION REQUIREMENTS AND FINAL STABILIZATION REQUIREMENTS. I ACKNOWLEDGE THE RESPONSIBILITY TO DETERMINE WHETHER THE CONSTRUCTION ACTIVITIES ON THESE PLANS REQUIRE COLORADO DISCHARGE PERMIT SYSTEM (CDPS) PERMITTING FOR STORMWATER DISCHARGES ASSOCIATED WITH CONSTRUCTION ACTIVITY."

NAME OF CONTRACTOR:

AUTHORIZED SIGNATURE:

DATE:

TITLE:

PHONE NUMBER:

ADDRESS:

EMAIL ADDRESS:

CITY PROJECT MANAGER'S STATEMENT

"I HEREBY CERTIFY THAT THE DRAINAGE, GRADING AND EROSION CONTROL FOR THE SAND CREEK DETENTION POND 2 RESTORATION SHALL BE CONSTRUCTED ACCORDING TO THE DESIGN PRESENTED IN THIS GRADING AND EROSION CONTROL PLAN. I FURTHER UNDERSTAND THAT THE FIELD CHANGES MUST BE REVIEWED BY THE SWENT REVIEW ENGINEER TO ENSURE CONFORMANCE WITH THE ORIGINAL DESIGN INTENT. I AM EMPLOYED BY AND PERFORM ENGINEERING SERVICES SOLELY FOR THE CITY OF COLORADO SPRINGS, AND THEREFORE AM EXEMPT FROM COLORADO REVISED STATUTE TITLE 12, ARTICLE 25, PART 1 ACCORDING TO § 12-25-103(1), C.R.S."

NAME OF CITY PROJECT MANAGER: Beau Thompson, PE

SIGNATURE: *[Signature]*

DATE: 9-17-24

CITY OF COLORADO SPRINGS GRADING AND EROSION CONTROL REVIEW

"THIS GRADING AND EROSION CONTROL PLAN IS FILED IN ACCORDANCE WITH CITY CODE. THIS PLAN IS REVIEWED IN ACCORDANCE WITH THE STORMWATER CONSTRUCTION MANUAL; LATEST REVISIONS."

[Signature]

DATE: 9/18/2024

FOR THE SWENT MANAGER

NOTES: STM-MP22-0417; STM-REV23-0749

The engineer, project manager, and review signature blocks are required on all Capital Improvement Projects GEC Plans prepared by an external consultant.

SAND CREEK DETENTION POND 2 RESTORATION STORMWATER MANAGEMENT PLAN FINAL DESIGN

PREPARED FOR:

CITY OF COLORADO SPRINGS, COLORADO STORMWATER ENTERPRISE

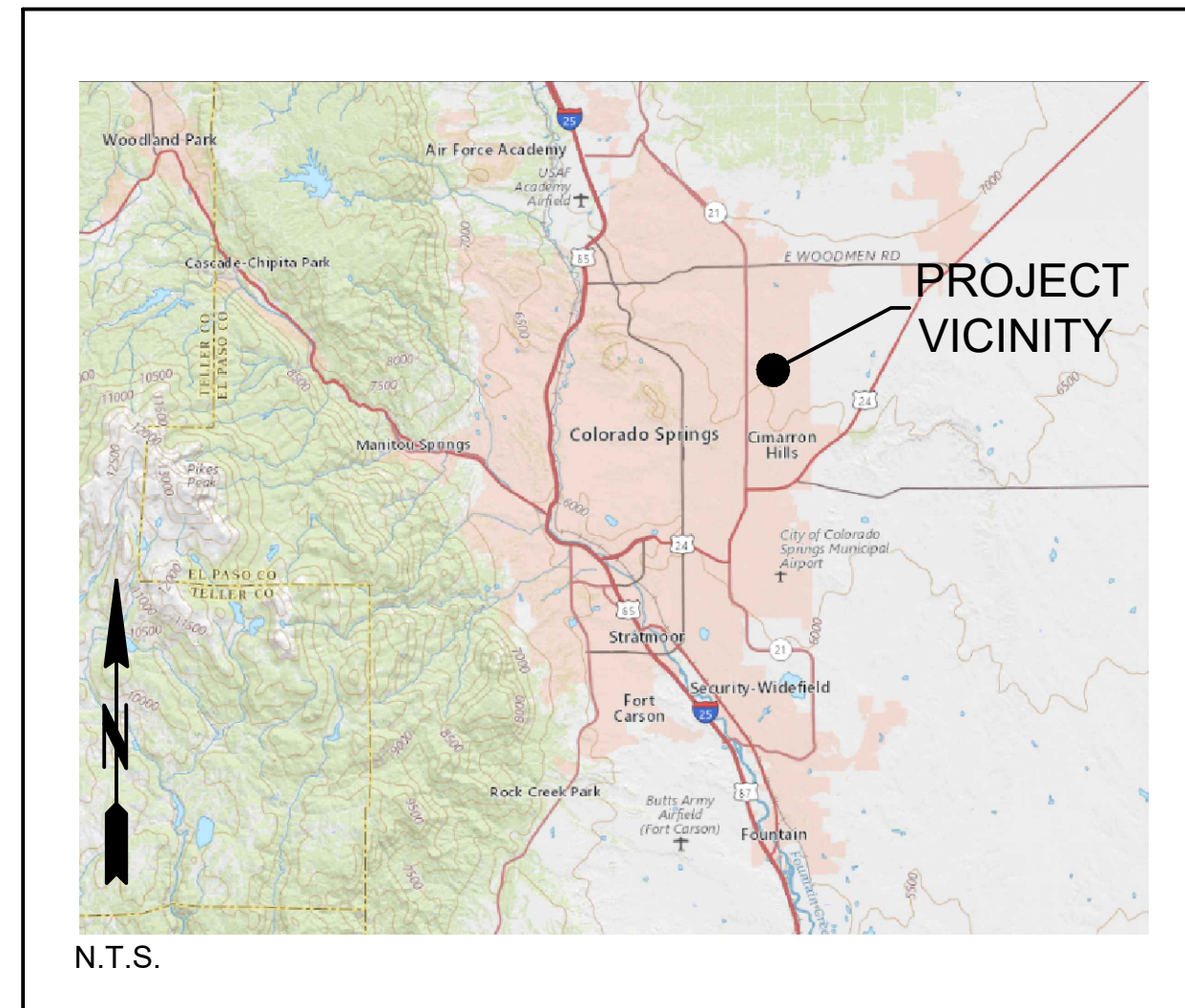

VICINITY MAP

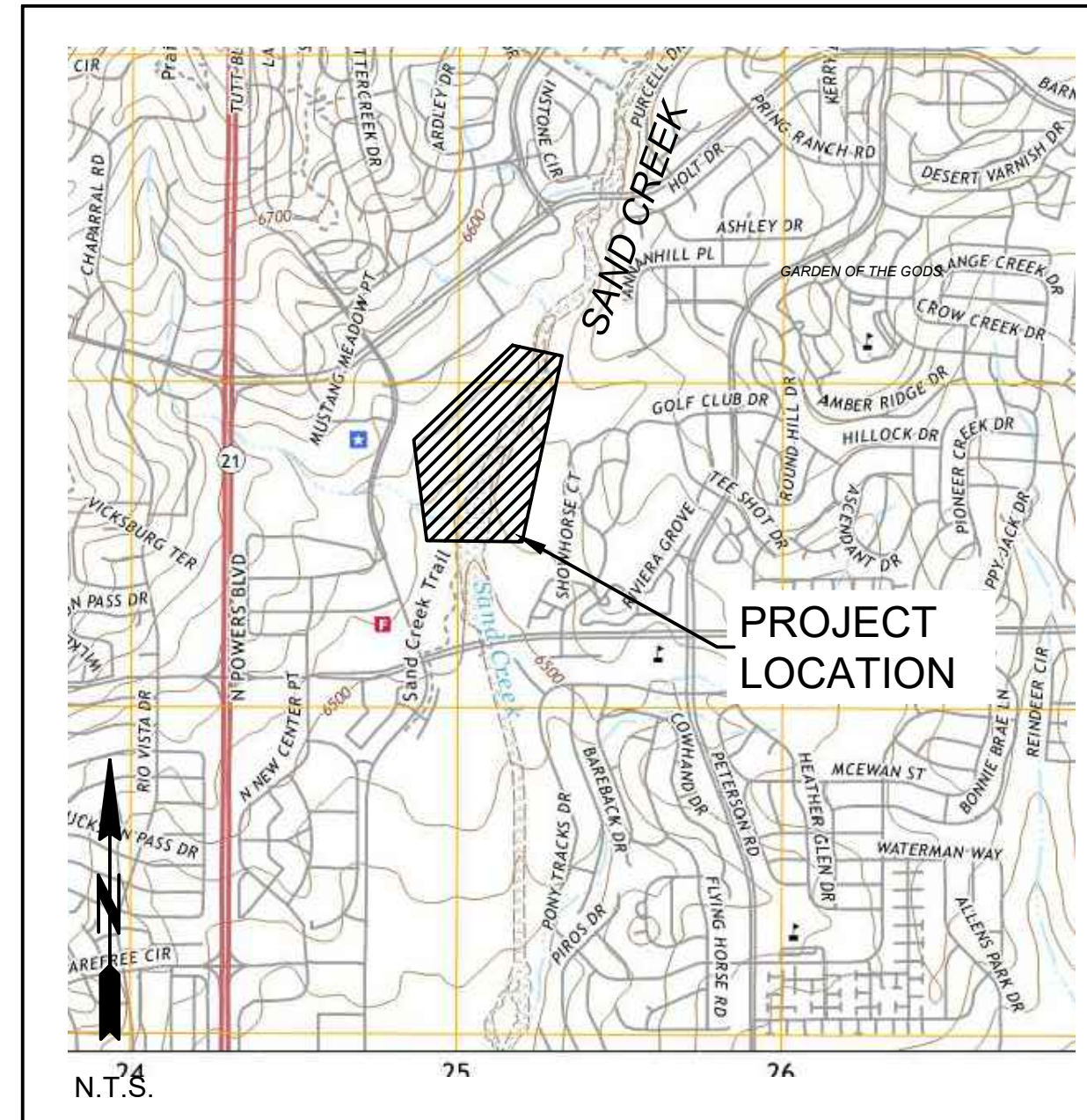

LOCATION MAP



CAUTION - NOTICE TO CONTRACTOR

THE CONTRACTOR IS SPECIFICALLY CAUTIONED THAT THE LOCATION AND/OR ELEVATION OF EXISTING UTILITIES SHOWN ON THESE PLANS IS BASED ON RECORDS OF THE VARIOUS UTILITY COMPANIES, AND WHERE POSSIBLE, MEASUREMENTS TAKEN IN THE FIELD.

THE INFORMATION IS NOT TO BE RELIED UPON AS BEING EXACT OR COMPLETE. THE CONTRACTOR MUST CALL THE APPROPRIATE UTILITY COMPANIES AT LEAST 72 HOURS BEFORE ANY EXCAVATION TO REQUEST EXACT FIELD LOCATION OF UTILITIES. IT SHALL BE THE RESPONSIBILITY OF THE CONTRACTOR TO RELOCATE ALL EXISTING UTILITIES WHICH CONFLICT WITH THE PROPOSED IMPROVEMENTS SHOWN ON THE PLANS.

AGENCY REFERRALS

**CITY OF COLORADO SPRINGS
STORMWATER ENTERPRISE**

30 S. NEVADA AVE., SUITE 401
COLORADO SPRINGS, CO. 80903
(719) 385-5980
CONTACT: BEAU THOMPSON, PE

COLORADO SPRINGS UTILITIES

111 S. CASCADE AVENUE
COLORADO SPRINGS, CO 80903
(719) 448-4800
CONTACT:

CIVIL ENGINEER	LANDSCAPE ARCHITECT	STRUCTURAL ENGINEER	GEOTECHNICAL ENGINEER	SURVEYOR	ENVIRONMENTAL
MERRICK & COMPANY 2480 W. 26TH AVENUE, SUITE B225 DENVER, CO 80211 (303) 964-3333 CONTACT: WALTER PENNINGTON, P.E.	THE ARCHITERRA GROUP 5881 SOUTH DEFRAME ST. LITTLETON, COLORADO 80127 (303) 948-0766 CONTACT: MARK TAYLOR, PLA, ASLA	SM&R STRUCTURAL ENGINEERS INC. 215 S. WADSWORTH BLVD, SUITE 320 LAKEWOOD, CO 80226 (303) 274-8656 CONTACT: DAVID BLANCHETTE, P.E.	VIVID ENGINEERING GROUP INC. 1053 ELKTON DRIVE COLORADO SPRINGS, CO 80907 (719) 896-4356 CONTACT: BRYSEN MUSTAIN	MERRICK & COMPANY 5970 GREENWOOD PLAZA BLVD GREENWOOD VILLAGE, CO 80111 (303) 751-0741 CONTACT: TODD BEERS, P.L.S.	CORVUS ENVIRONMENTAL CONSULTING, LLC. 6429 S. MARION PLACE CENTENNIAL, CO 80121 (303) 250-2118 CONTACT: TIM DEMASTERS

REV	REVISION DESCRIPTION	DATE	CHND	CHKD	APPR

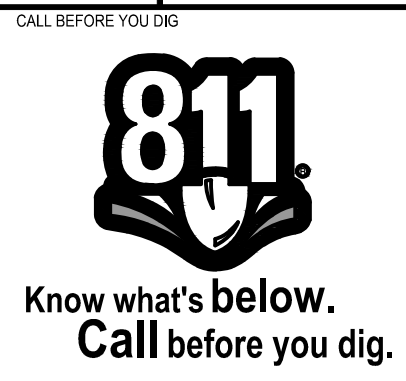

CITY OF COLORADO SPRINGS
30 S. NEVADA AVE., SUITE 401
COLORADO SPRINGS, CO 80903
(719) 385-5980

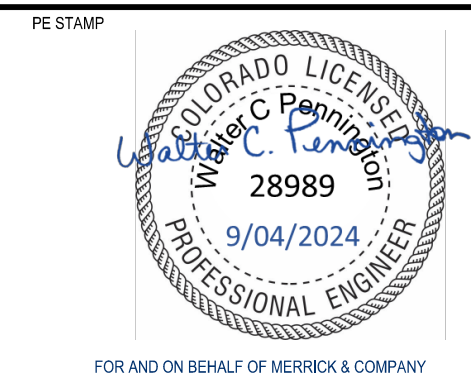

TITLE: SAND CREEK DETENTION POND NO. 2

EROSION CONTROL COVER SHEET

JOB NUMBER	65420975
DATE	AUGUST 2024
SHEET	EC-101
1 of 9	

THE USE OF ANY SERVICE OR MATERIALS IS AN INDICATION OF SERVICE PROVIDED BY MERRICK AND COMPANY FOR A SPECIFIC PROJECT. IT IS NOT INTENDED OR REPRESENTED TO BE SUITABLE FOR REUSE OR PART OR ENTIRETY OF THE PROJECT OR ON ANY OTHER PROJECT. REUSE OR MODIFICATION OF ANY INFORMATION WITHOUT THE PRIOR EXPRESS WRITTEN CONSENT OF MERRICK AND COMPANY SHALL BE AT THE USER'S RISK. THE USER ASSUMES ALL LIABILITY FOR SUCH REUSE OR MODIFICATION.

File Location: Q:\Denver_North\Projects\City of Colorado Springs\Sand Creek Pond No. 2\CAD\CD3\0875 - EROSION-CONTROL-COVER.dwg Plot Date: 8/27/2024 11:23 AM Last Saved By: TIM.MCMILLEN

EROSION CONTROL NOTES

1. NO CLEARING, GRADING, EXCAVATION, OR OTHER LAND DISTURBING ACTIVITIES SHALL BE ALLOWED (EXCEPT FOR WORK DIRECTLY RELATED TO THE INSTALLATION OF INITIAL CONTROL MEASURES) UNTIL A CITY GEC PERMIT HAS BEEN ISSUED.
2. ALL LAND DISTURBING ACTIVITIES MUST BE PERFORMED IN ACCORDANCE WITH THE APPROVED GEC PLAN AND CSWMP.
3. INITIAL CONTROL MEASURES SHALL BE INSTALLED AND INSPECTED PRIOR TO ANY LAND DISTURBANCE ACTIVITIES TAKING PLACE. AN INITIAL SITE INSPECTION WILL NOT BE SCHEDULED UNTIL A CITY GEC PERMIT HAS BEEN "CONDITIONALLY APPROVED." CALL CITY STORMWATER INSPECTIONS, 385-5980, AT LEAST 48 HOURS PRIOR TO CONSTRUCTION TO SCHEDULE AN INITIAL INSPECTION AND OBTAIN FULL PERMIT APPROVAL.
4. INDIVIDUALS SHALL COMPLY WITH THE "COLORADO WATER QUALITY CONTROL ACT" (TITLE 25, ARTICLE 8, CRS) AND THE "CLEAN WATER ACT" (33 USC 1344), INCLUDING REGULATIONS PROMULGATED AND CERTIFICATIONS OR PERMITS ISSUED, IN ADDITION TO THE REQUIREMENTS INCLUDED IN THE CITY'S MS4 PERMIT, STORMWATER CONSTRUCTION MANUAL. IN THE EVENT OF CONFLICTS BETWEEN THESE REQUIREMENTS AND WATER QUALITY CONTROL LAWS, RULES, OR REGULATIONS OF OTHER FEDERAL OR STATE AGENCIES, THE MORE RESTRICTIVE LAWS, RULES, OR REGULATIONS SHALL APPLY.
5. STORMWATER DISCHARGES FROM CONSTRUCTION SITES SHALL NOT CAUSE OR THREATEN TO CAUSE POLLUTION, CONTAMINATION, OR DEGRADATION OF STATE WATERS.
6. ALL CONSTRUCTION CONTROL MEASURES SHALL BE MAINTAINED UNTIL PERMANENT STABILIZATION MEASURES ARE IMPLEMENTED. TEMPORARY CONSTRUCTION CONTROL MEASURES MUST BE REMOVED PRIOR TO PERMIT CLOSEOUT.
7. CONCRETE WASH WATER SHALL NOT BE DISCHARGED TO OR ALLOWED TO RUNOFF TO STATE WATERS OR ANY SURFACE OR SUBSURFACE STORM DRAINAGE SYSTEM OR FACILITIES.
8. BUILDING, CONSTRUCTION, EXCAVATION, OR OTHER WASTE MATERIALS SHALL NOT BE TEMPORARILY PLACED OR STORED IN THE STREET, ALLEY, OR OTHER PUBLIC WAY, UNLESS IN ACCORDANCE WITH AN APPROVED TRAFFIC CONTROL PLAN. CONSTRUCTION CONTROL MEASURES MAY BE REQUIRED BY THE GEC INSPECTOR IF DEEMED NECESSARY BASED ON SPECIFIC CONDITIONS AND CIRCUMSTANCES (E.G., ESTIMATED TIME OF EXPOSURE, SEASON OF THE YEAR, ETC.).
9. ALL WASTES COMPOSED OF BUILDING MATERIALS MUST BE REMOVED FROM THE CONSTRUCTION SITE FOR DISPOSAL IN ACCORDANCE WITH LOCAL AND STATE REGULATORY REQUIREMENTS. NO BUILDING MATERIAL WASTES OR UNUSED BUILDING MATERIALS SHALL BE BURIED, DUMPED, OR DISCHARGED AT THE SITE.
10. THE PERMITTEE SHALL BE RESPONSIBLE FOR THE REMOVAL OF ALL CONSTRUCTION DEBRIS, DIRT, TRASH, ROCK, SEDIMENT, AND SAND THAT MAY ACCUMULATE IN THE STORM SEWER OR OTHER DRAINAGE CONVEYANCE SYSTEM AS A RESULT OF CONSTRUCTION ACTIVITIES.
11. THE QUANTITY OF MATERIALS STORED ON THE PROJECT SITE SHALL BE LIMITED, AS MUCH AS PRACTICAL, TO THAT QUANTITY REQUIRED TO PERFORM THE WORK IN AN ORDERLY SEQUENCE. ALL MATERIALS STORED ON-SITE SHALL BE STORED IN A NEAT, ORDERLY MANNER, IN THEIR ORIGINAL CONTAINERS, WITH ORIGINAL MANUFACTURER'S LABELS. MATERIALS SHALL NOT BE STORED IN A LOCATION WHERE THEY MAY BE CARRIED BY STORMWATER RUNOFF INTO THE STORM SEWER SYSTEM AT ANY TIME.
12. SPILL PREVENTION AND CONTAINMENT MEASURES SHALL BE USED AT ALL STORAGE, EQUIPMENT FUELING, AND EQUIPMENT SERVICING AREAS SO AS TO CONTAIN ALL SPILLS AND PREVENT ANY SPILLED MATERIAL FROM ENTERING THE MS4, INCLUDING ANY SURFACE OR SUBSURFACE STORM DRAINAGE SYSTEM OR FACILITY. BULK STORAGE STRUCTURES FOR PETROLEUM PRODUCTS AND OTHER CHEMICALS SHALL HAVE SECONDARY CONTAINMENT OR EQUIVALENT ADEQUATE PROTECTION. ALL SPILLS SHALL BE CLEANED UP IMMEDIATELY AFTER DISCOVERY, OR CONTAINED UNTIL APPROPRIATE CLEANUP METHODS CAN BE EMPLOYED. MANUFACTURER'S RECOMMENDED METHODS FOR SPILL CLEANUP SHALL BE FOLLOWED, ALONG WITH PROPER DISPOSAL METHODS.
13. SEDIMENT (MUD AND DIRT) TRANSPORTED ONTO A PUBLIC ROAD, REGARDLESS OF THE SIZE OF THE SITE, SHALL BE CLEANED AS SOON AS POSSIBLE AFTER DISCOVERY.
14. NO CHEMICALS ARE TO BE ADDED TO THE DISCHARGE UNLESS PERMISSION FOR THE USE OF A SPECIFIC CHEMICAL IS GRANTED BY THE STATE. IN GRANTING THE USE OF SUCH CHEMICALS, SPECIAL CONDITIONS AND MONITORING MAY BE REQUIRED.
15. CONTROL MEASURES FOR ALL SLOPES, CHANNELS, DITCHES, OR ANY DISTURBED LAND AREA SHALL BE COMPLETED WITHIN FOURTEEN (14) CALENDAR DAYS AFTER FINAL GRADING OR FINAL LAND DISTURBANCE HAS BEEN COMPLETED. DISTURBED AREAS WHICH ARE NOT AT FINAL GRADE BUT WILL REMAIN DORMANT FOR LONGER THAN FOURTEEN (14) DAYS SHALL BE ROUGHENED, MULCHED, TACKIFIED, OR STABILIZED WITH TARPS WITHIN FOURTEEN (14) DAYS AFTER INTERIM GRADING. AN AREA THAT IS GOING TO REMAIN IN AN INTERIM STATE FOR MORE THAN SIXTY (60) DAYS SHALL ALSO BE SEEDED, UNLESS AN ALTERNATIVE STABILIZATION MEASURE IS ACCEPTED AT THE INSPECTOR'S DISCRETION. ALL TEMPORARY CONSTRUCTION CONTROL MEASURES SHALL BE MAINTAINED UNTIL FINAL STABILIZATION IS ACHIEVED.
16. THE GEC PLAN WILL BE SUBJECT TO RE-REVIEW AND RE-ACCEPTANCE BY THE STORMWATER ENTERPRISE SHOULD ANY OF THE FOLLOWING OCCUR: GRADING DOES NOT COMMENCE WITHIN TWELVE (12) MONTHS OF THE CITY'S ACCEPTANCE OF THE PLAN, THE CONSTRUCTION SITE IS IDLE FOR TWELVE (12) CONSECUTIVE MONTHS, A CHANGE IN PROPERTY OWNERSHIP OCCURS, THE PLANNED DEVELOPMENT CHANGES, OR ANY OTHER MAJOR MODIFICATIONS ARE PROPOSED AS DEFINED IN THE STORMWATER CONSTRUCTION MANUAL.
17. IT IS NOT PERMISSIBLE FOR ANY PERSON TO MODIFY THE GRADE OF THE EARTH ON ANY UTILITY EASEMENT OR UTILITY RIGHT-OF-WAY WITHOUT WRITTEN APPROVAL FROM THE UTILITY OWNER. CITY ACCEPTANCE OF THE GEC PLAN AND CSWMP DOES NOT SATISFY THIS REQUIREMENT. THE PLAN SHALL NOT INCREASE OR DIVERT WATER TOWARDS UTILITY FACILITIES. ANY CHANGES TO EXISTING UTILITY FACILITIES TO ACCOMMODATE THE PLAN MUST BE APPROVED BY THE AFFECTED UTILITY OWNER PRIOR TO IMPLEMENTING THE PLAN. THE COST TO RELOCATE OR PROTECT EXISTING UTILITIES OR TO PROVIDE INTERIM ACCESS SHALL BE AT THE APPLICANT'S EXPENSE.
18. APPLICANT REPRESENTS AND WARRANTS THAT THEY HAVE THE LEGAL AUTHORITY TO GRADE AND/OR CONSTRUCT IMPROVEMENTS ON ADJACENT PROPERTY. THE CITY HAS NOT REVIEWED THE DEVELOPER'S AUTHORITY TO MODIFY ADJACENT PROPERTY. AN APPROVED GEC PERMIT DOES NOT PROVIDE APPROVAL FOR THE APPLICANT TO PERFORM WORK ON ADJACENT PROPERTY.

SITE SPECIFIC EROSION CONTROL NOTES

19. ONSITE STOCKPILE LOCATIONS TO BE DETERMINED BY CONTRACTOR. LOCATION SHALL NOT RESULT IN ANY ADDITIONAL LAND DISTURBANCE. ALL EXCESS SOIL MUST BE HAULED OFFSITE TO LOCATION IDENTIFIED BY CITY AND STOCKPILED. PROVIDE EROSION PROTECTION PER THE GEC.
20. INSPECT PAVED ROADS AROUND THE PERIMETER OF THE CONSTRUCTION SITE ON A DAILY BASIS AND MORE FREQUENTLY AS NEEDED. REMOVE ACCUMULATED SEDIMENT, AS NEEDED. INSPECT AREA TO BE SWEEP FOR MATERIALS THAT MAY BE HAZARDOUS PRIOR TO BEGINNING SWEEPING OPERATIONS.
21. LOCATION OF EXISTING OR PROPOSED WATER COURSES TO INCLUDE BUT NOT LIMITED TO GROUND WATER SPRINGS, STREAMS, WETLANDS, OR OTHER SURFACE WATERS, INCLUDING AREAS WHERE THE COR400000 REQUIRES THAT PRE-EXISTING VEGETATION BE MAINTAINED WITHIN 50 FEET OF A RECEIVING WATER.
22. NO "NO-BUILD AREAS" HAVE BEEN IDENTIFIED BY A GEOLOGIC HAZARD STUDY.
23. NO ASPHALT, CONCRETE BATCH PLANTS, OR MASONRY MIX WILL BE STATIONS ON SITE.
24. ANTICIPATED CONSTRUCTION START DATE IS OCTOBER 2024.
25. ANTICIPATED COMPLETION DATE IS FEBRUARY 2025.
26. ANTICIPATED FINAL STABILIZATION DATE IS JUNE 2026.
27. RECEIVING WATERS: SAND CREEK IS TRIBUTARY TO FOUNTAIN CREEK.
28. THERE ARE NO PLANNED INFILTRATION AREAS (PIAs) ON THIS SITE.

REV	REVISION DESCRIPTION	DATE	CHND	CHKD	APPR

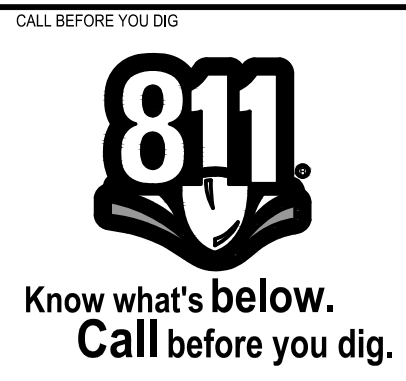

CITY OF COLORADO SPRINGS
30 S. NEVADA AVE., SUITE 401
COLORADO SPRINGS, CO 80903
(719) 385-5980

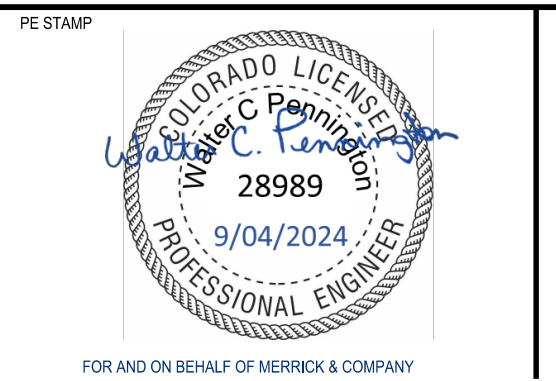

TITLE: **SAND CREEK DETENTION POND NO. 2**
EROSION CONTROL NOTES

JOB NUMBER	65420975
DATE	AUGUST 2024
SHEET	EC-102
2	of 9

THE CITY OF COLORADO SPRINGS IS PROVIDING THIS INFORMATION AS A SERVICE TO THE PUBLIC. IT IS NOT INTENDED OR REPRESENTED TO BE A SUBSTITUTE FOR PROFESSIONAL ENGINEERING OR ARCHITECTURAL SERVICES. THE CITY OF COLORADO SPRINGS DOES NOT WARRANT THE ACCURACY OF ANY INFORMATION OR REPRESENTATION. WITHOUT THE PRIOR WRITTEN CONSENT OF MERRICK AND COMPANY, THIS INFORMATION SHALL NOT BE REPRODUCED OR TRANSMITTED IN ANY FORM OR BY ANY MEANS, ELECTRONIC OR MECHANICAL, INCLUDING PHOTOCOPYING, RECORDING, OR BY ANY INFORMATION STORAGE AND RETRIEVAL SYSTEM.

File Location: D:\Denver_North\Projects\City of Colorado Springs\Sand Creek Pond No. 2\CAD\0975-EROSION-CONTROL-PLAN-INITIAL.dwg Plot Date: 8/27/2024 11:23 AM Last Saved By: TIM/MCMULLEN

MATCHLINE SEE SHEET EC-202

NOTE: SEE DWG. L-100 (LANDSCAPING PLAN) FOR SEEDING AND PLANTING

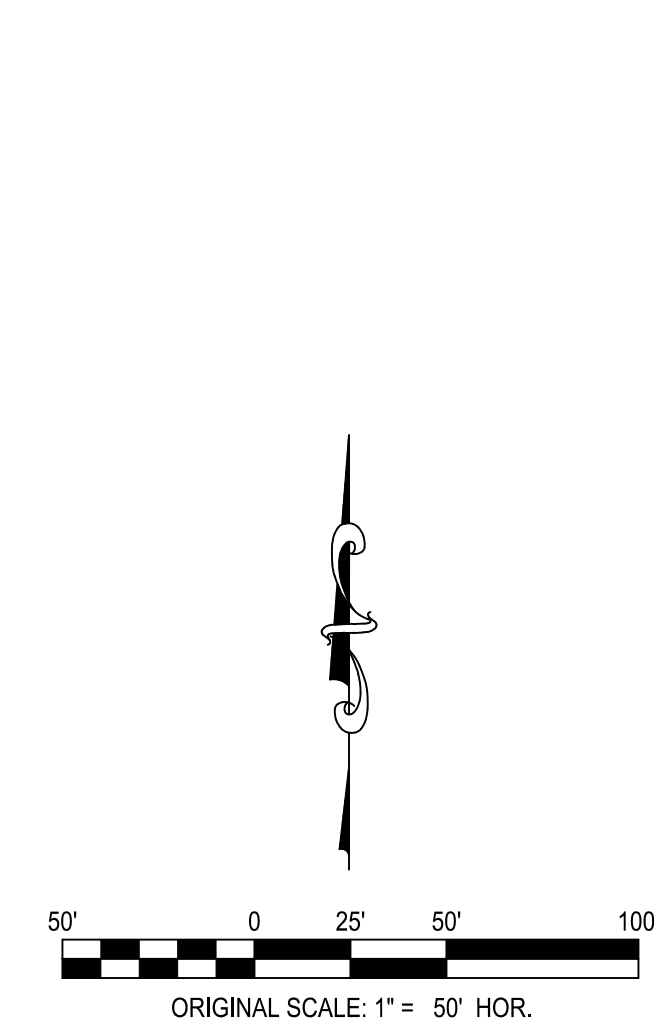
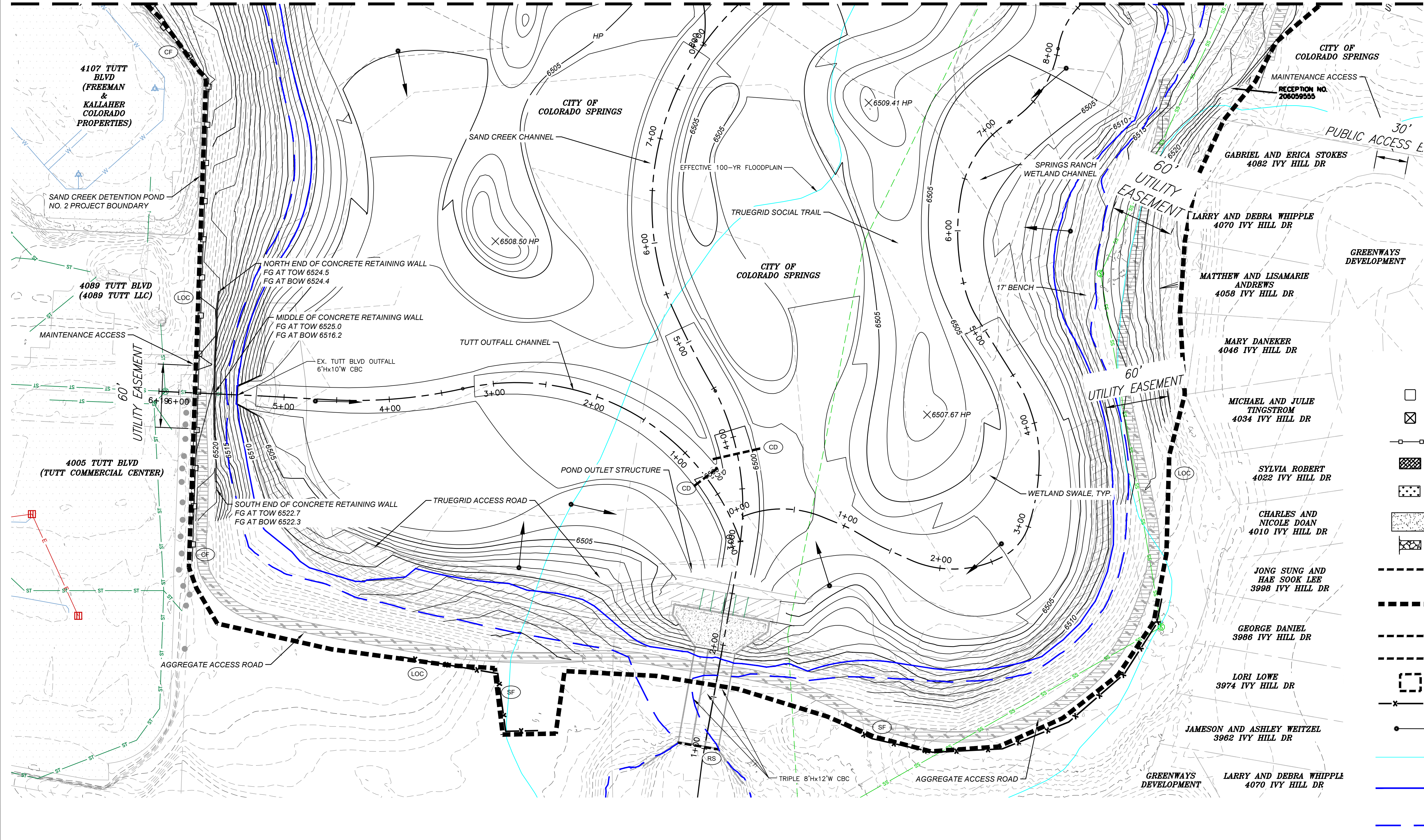

BMP LEGEND

	(CWA)	CONCRETE WASHOUT AREA
	(PT)	PORTABLE TOILET
	(CF)	TEMPORARY CONSTRUCTION FENCE
	(ECB)	EROSION CONTROL BLANKET
	(SM)	SEEDING AND MULCHING
	(SSA)	STABILIZED STAGING AREA
	(VTC)	VEHICLE TRACKING CONTROL
	(CIP)	CULVERT INLET PROTECTION
	(LOC)	LIMITS OF CONSTRUCTION/ LIMITS OF DISTURBANCE (22.1 AC)
	(RS)	ROCK SOCK
	(CD)	CHECK DAM
	(IP-2)	SUMP INLET PROTECTION
	(SF)	SILT FENCE
		FLOW DIRECTION
		EXISTING REGULATORY 100-YEAR FLOODPLAIN
		PROPOSED DESIGN 100-YEAR FLOODPLAIN
		PROPOSED REGULATORY 100-YEAR FLOODPLAIN
		PROPERTY LINE

PLAN
SCALE: 1" = 50'

REV	REVISION DESCRIPTION	DATE	CHND	CHKD	APPR

CALL BEFORE YOU DIG

Know what's below.
Call before you dig.

CITY OF COLORADO SPRINGS
30 S. NEVADA AVE., SUITE 401
COLORADO SPRINGS, CO 80903
(719) 385-5980

Engineering | Architecture | Design-Build | Surveying | Planning | Geospatial Solutions
2480 W. 26TH AVE., UNIT B225 - DENVER COLORADO 80211
TEL. 303-751-0741, FAX 303-751-2581
www.merrick.com

PE STAMP

FOR AND ON BEHALF OF MERRICK & COMPANY

TITLE

SAND CREEK DETENTION POND NO. 2

GRADING AND EROSION CONTROL (GEC) PLAN (SOUTH)

INITIAL/INTERIM

JOB NUMBER: 65420975

DATE: AUGUST 2024













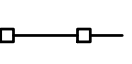

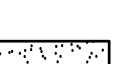

SHEET: **EC-201**

3 of 9

THE CITY OF COLORADO SPRINGS IS PROVIDING THIS INFORMATION AS A SERVICE TO THE PUBLIC. IT IS NOT A WARRANTY OF ANY KIND. THE CITY OF COLORADO SPRINGS DOES NOT WARRANT THE ACCURACY OF ANY INFORMATION OR REPRESENTATION. THE CITY OF COLORADO SPRINGS DOES NOT WARRANT THE ACCURACY OF ANY INFORMATION OR REPRESENTATION. THE CITY OF COLORADO SPRINGS DOES NOT WARRANT THE ACCURACY OF ANY INFORMATION OR REPRESENTATION.

File Location: D:\Denver_North\Projects\City of Colorado Springs\Sand Creek Pond No. 2\CAD\CCS\0975-EROSION-CONTROL-PLAN-INITIAL.dwg Plot Date: 8/27/2024 11:23 AM Last Saved By: TIM WCMULLEN

BMP LEGEND

-  CWA CONCRETE WASHOUT AREA
-  PT PORTABLE TOILET
-  CF TEMPORARY CONSTRUCTION FENCE
-  ECB EROSION CONTROL BLANKET
-  SM SEEDING AND MULCHING
-  SSA STABILIZED STAGING AREA
-  VTC VEHICLE TRACKING CONTROL
-  CIP CULVERT INLET PROTECTION
-  LOC LIMITS OF CONSTRUCTION/
LIMITS OF DISTURBANCE (22.1 AC)
-  RS ROCK SOCK
-  CD CHECK DAM
-  IP-2 SUMP INLET PROTECTION
-  SF SILT FENCE
-  FLOW DIRECTION
-  EXISTING REGULATORY
100-YEAR FLOODPLAIN
-  PROPOSED DESIGN
100-YEAR FLOODPLAIN
-  PROPOSED REGULATORY
100-YEAR FLOODPLAIN
-  PROPERTY LINE

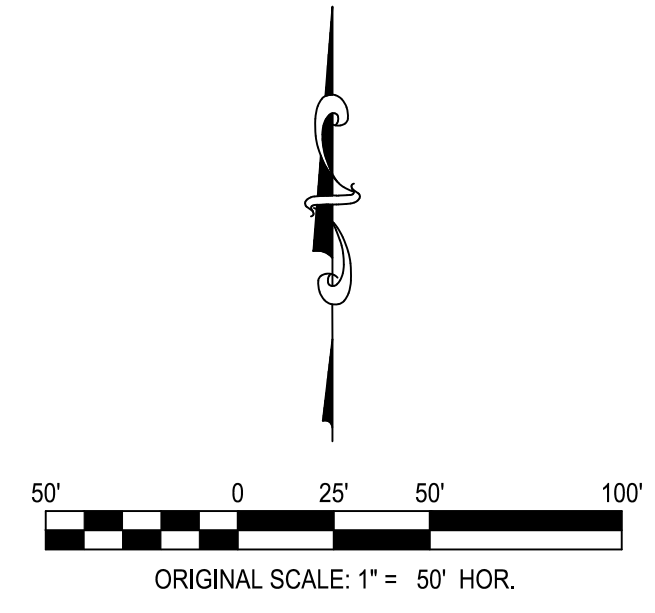
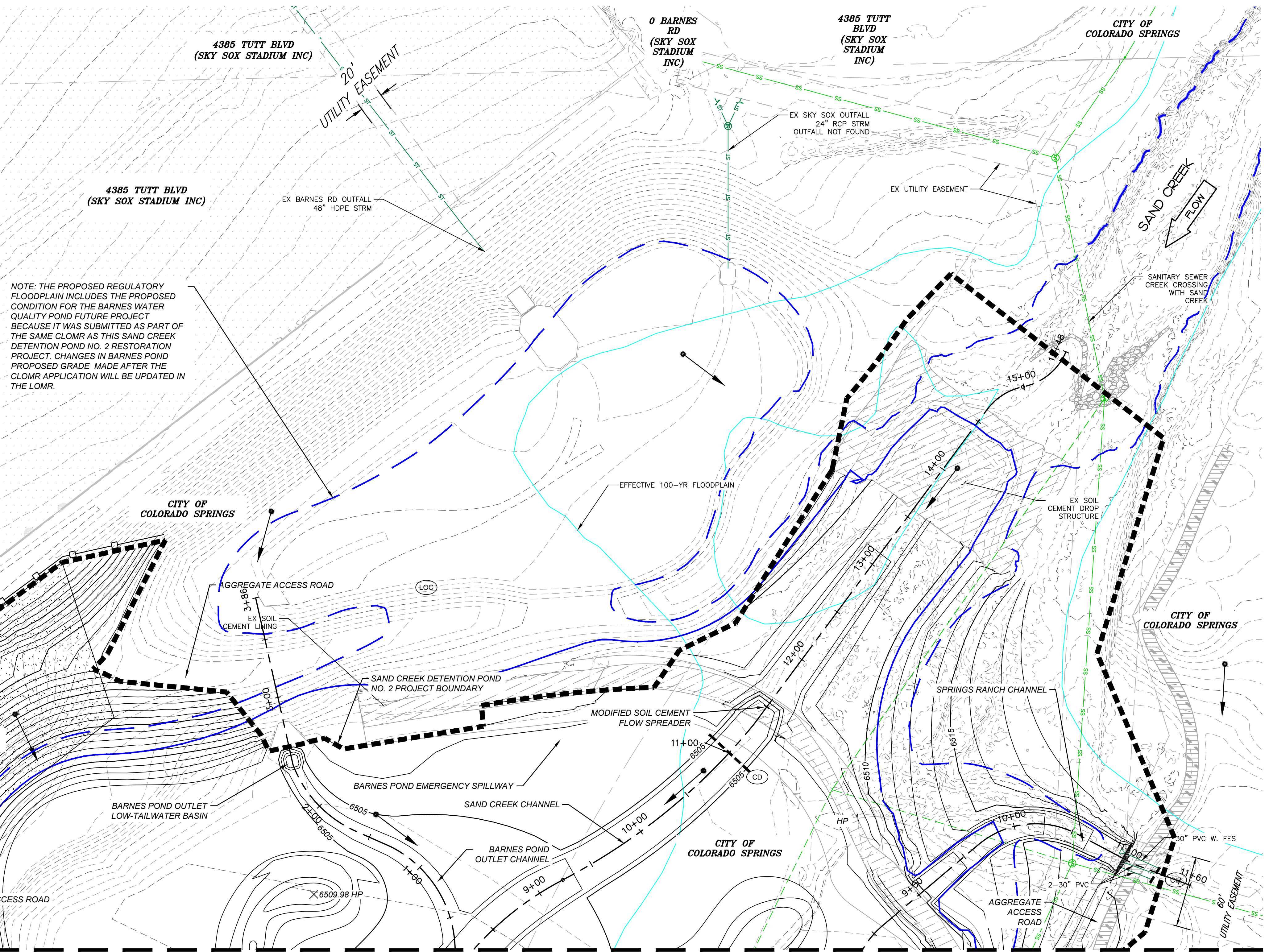

PLAN
 SCALE 1" = 50'
 MATCHLINE SEE SHEET EC-201

REV	REVISION DESCRIPTION	DATE	CHND	CHKD	APPR

CALL BEFORE YOU DIG



Know what's below.
 Call before you dig.

CITY OF COLORADO SPRINGS
 30 S. NEVADA AVE., SUITE 401
 COLORADO SPRINGS, CO 80903
 (719) 385-5980



Engineering | Architecture | Design-Build | Surveying | Planning | Geospatial Solutions
 2480 W. 26TH AVE., UNIT B225 - DENVER COLORADO 80211
 TEL. 303-751-0741, FAX 303-751-2581
 www.merrick.com

PE STAMP



FOR AND ON BEHALF OF MERRICK & COMPANY

SAND CREEK DETENTION POND NO. 2
 GRADING AND EROSION CONTROL (GEC) PLAN (NORTH)
 INITIAL/INTERIM

JOB NUMBER: 65420975
 DATE: AUGUST 2024
 SHEET: **EC-202**
 4 of 9

THE CITY OF COLORADO SPRINGS IS PROVIDING THIS INFORMATION AS A SERVICE TO THE PUBLIC. IT IS NOT INTENDED OR REPRESENTED TO BE A BASIS FOR ANY CONTRACT OR PART THEREOF. THE CITY OF COLORADO SPRINGS DOES NOT WARRANT, REPRESENT, OR GUARANTEE THE ACCURACY, COMPLETENESS, OR RELIABILITY OF ANY INFORMATION PROVIDED HEREON. WITHOUT THE WRITTEN CONSENT OF MERRICK AND COMPANY, THIS INFORMATION SHALL NOT BE REPRODUCED OR TRANSMITTED IN ANY FORM OR BY ANY MEANS, ELECTRONIC OR MECHANICAL, INCLUDING PHOTOCOPYING, RECORDING, OR BY ANY INFORMATION STORAGE AND RETRIEVAL SYSTEM.

File Location: D:\Denver_North\Projects\City of Colorado Springs\Sand Creek Pond No. 2\CAD\0975-EROSION-CONTROL-PLAN.dwg Plot Date: 8/27/2024 11:23 AM Last Saved By: TIM.MCMILLEN

MATCHLINE SEE SHEET EC-302

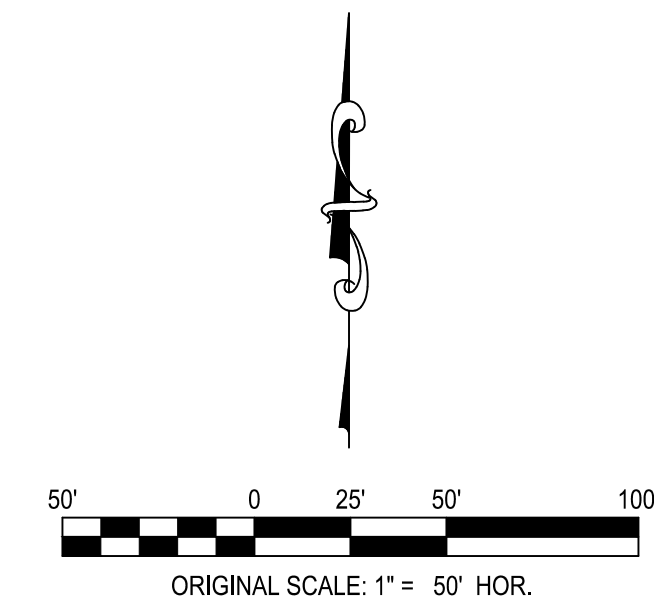
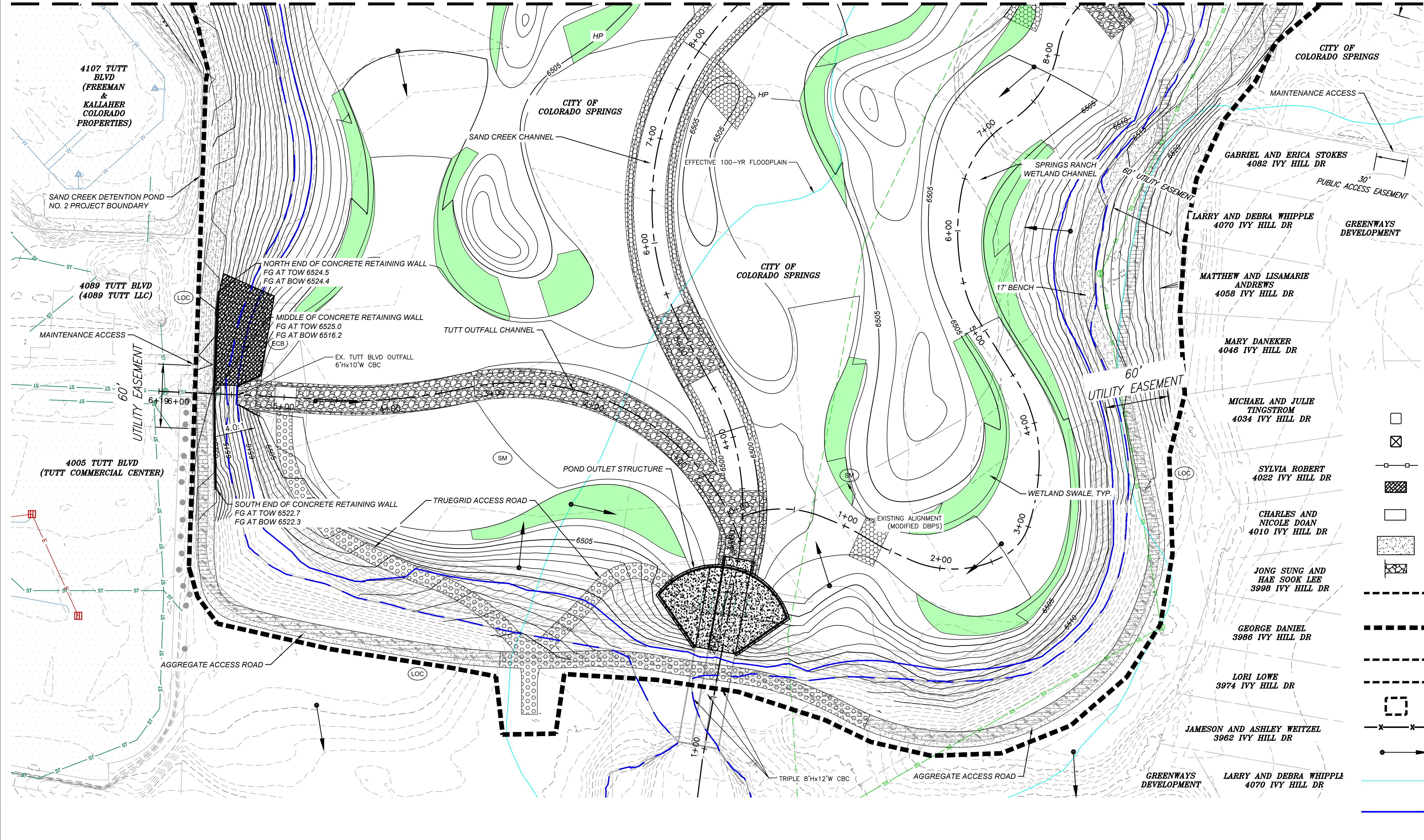

BMP LEGEND

	(CWA)	CONCRETE WASHOUT AREA
	(PT)	PORTABLE TOILET
	(CF)	TEMPORARY CONSTRUCTION FENCE
	(ECB)	EROSION CONTROL BLANKET
	(SM)	SEEDING AND MULCHING
	(SSA)	STABILIZED STAGING AREA
	(VTC)	VEHICLE TRACKING CONTROL
	(CIP)	CULVERT INLET PROTECTION
	(LOC)	LIMITS OF CONSTRUCTION/ LIMITS OF DISTURBANCE (22.1 AC)
	(RS)	ROCK SOCK
	(CD)	CHECK DAM
	(IP-2)	SUMP INLET PROTECTION
	(SF)	SILT FENCE
		FLOW DIRECTION
		EXISTING REGULATORY 100-YEAR FLOODPLAIN
		PROPOSED DESIGN 100-YEAR FLOODPLAIN
		PROPOSED REGULATORY 100-YEAR FLOODPLAIN
		PROPERTY LINE

PLAN
SCALE: 1" = 50'

REV	REVISION DESCRIPTION	DATE	CHND	CHKD	APPR

CALL BEFORE YOU DIG

Know what's below.
Call before you dig.

CITY OF COLORADO SPRINGS
30 S. NEVADA AVE., SUITE 401
COLORADO SPRINGS, CO 80903
(719) 385-5980

MERRICK
Engineering | Architecture | Design-Build | Surveying | Planning | Geospatial Solutions
2480 W. 26TH AVE., UNIT B225 - DENVER COLORADO 80211
TEL. 303-751-0741, FAX 303-751-2581
www.merrick.com

PE STAMP

FOR AND ON BEHALF OF MERRICK & COMPANY













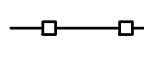

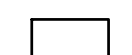
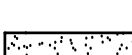
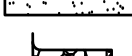

TITLE
SAND CREEK DETENTION POND NO. 2
GRADING AND EROSION CONTROL (GEC) PLAN (SOUTH)
FINAL

JOB NUMBER: 65420975
 DATE: AUGUST 2024
 SHEET: **EC-301**
 5 of 9

THE CITY OF COLORADO SPRINGS IS PROVIDING THIS INFORMATION AS A SERVICE TO THE PUBLIC. THE CITY DOES NOT WARRANT THE ACCURACY OF THE INFORMATION PROVIDED. THE CITY IS NOT RESPONSIBLE FOR ANY DAMAGE TO PROPERTY OR PERSONS ARISING FROM THE USE OF THIS INFORMATION. THE CITY IS NOT PROVIDING THIS INFORMATION AS A SERVICE TO THE PUBLIC. THE CITY DOES NOT WARRANT THE ACCURACY OF THE INFORMATION PROVIDED. THE CITY IS NOT RESPONSIBLE FOR ANY DAMAGE TO PROPERTY OR PERSONS ARISING FROM THE USE OF THIS INFORMATION.

File Location: D:\Denver_North\Projects\City of Colorado Springs\Sand Creek Pond No. 2\CAD\CCS\0875-EROSION-CONTROL-PLAN.dwg Plot Date: 8/27/2024 11:23 AM Last Saved By: TIM.MCMILLEN

BMP LEGEND

-  (CWA) CONCRETE WASHOUT AREA
-  (PT) PORTABLE TOILET
-  (CF) TEMPORARY CONSTRUCTION FENCE
-  (ECB) EROSION CONTROL BLANKET
-  (SM) SEEDING AND MULCHING
-  (SSA) STABILIZED STAGING AREA
-  (VTC) VEHICLE TRACKING CONTROL
-  (CIP) CULVERT INLET PROTECTION
-  (LOC) LIMITS OF CONSTRUCTION/
LIMITS OF DISTURBANCE (22.1 AC)
-  (RS) ROCK SOCK
-  (CD) CHECK DAM
-  (IP-2) SUMP INLET PROTECTION
-  (SF) SILT FENCE
-  FLOW DIRECTION
-  EXISTING REGULATORY
100-YEAR FLOODPLAIN
-  PROPOSED DESIGN
100-YEAR FLOODPLAIN
-  PROPOSED REGULATORY
100-YEAR FLOODPLAIN
-  PROPERTY LINE

NOTE: THE PROPOSED REGULATORY
 FLOODPLAIN INCLUDES THE PROPOSED
 CONDITION FOR THE BARNES WATER
 QUALITY POND FUTURE PROJECT
 BECAUSE IT WAS SUBMITTED AS PART OF
 THE SAME CLOMR AS THIS SAND CREEK
 DETENTION POND NO. 2 RESTORATION
 PROJECT. CHANGES IN BARNES POND
 PROPOSED GRADE MADE AFTER THE
 CLOMR APPLICATION WILL BE UPDATED IN
 THE LOMR.

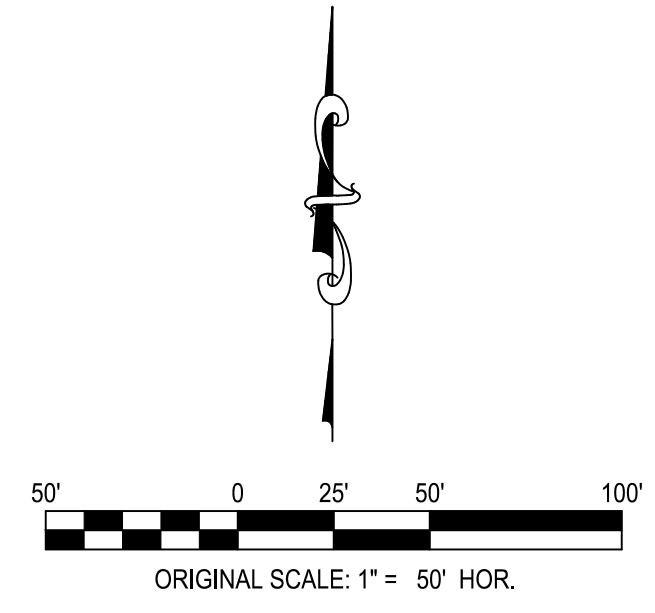
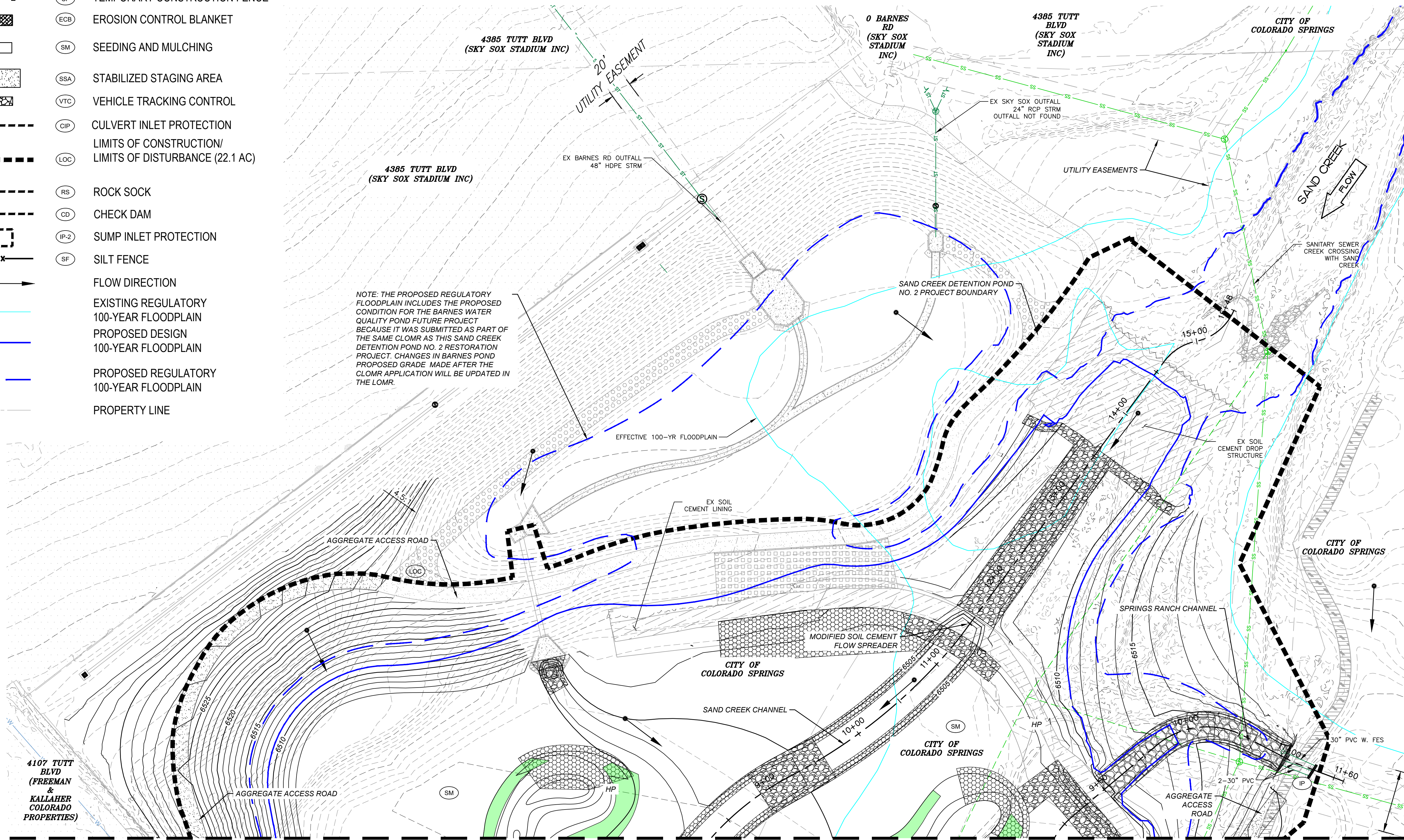

PLAN
 SCALE 1" = 50'
 MATCHLINE SEE SHEET EC-301

REV	REVISION DESCRIPTION	DATE	CHND	CHKD	APPR

CALL BEFORE YOU DIG

 Know what's below.
 Call before you dig.

CITY OF COLORADO SPRINGS
 30 S. NEVADA AVE., SUITE 401
 COLORADO SPRINGS, CO 80903
 (719) 385-5980

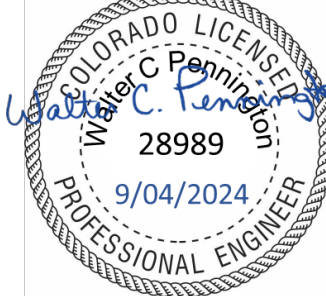
MERRICK
 Engineering | Architecture | Design-Build | Surveying | Planning | Geospatial Solutions
 2480 W. 26TH AVE., UNIT B225 - DENVER COLORADO 80211
 TEL. 303-751-0741, FAX 303-751-2581
 www.merrick.com

PE STAMP

 W. C. Pennington
 28989
 9/04/2024
 PROFESSIONAL ENGINEER
 FOR AND ON BEHALF OF MERRICK & COMPANY

TITLE
SAND CREEK DETENTION POND NO. 2
 GRADING AND EROSION CONTROL (GEC) PLAN (NORTH)
 FINAL

JOB NUMBER 65420975
 DATE AUGUST 2024
 SHEET **EC-302**
 6 of 9

THE CITY OF COLORADO SPRINGS IS AN INSTRUMENT OF SERVICE PROVIDED BY MERRICK & COMPANY, P.C., A REGISTERED PROFESSIONAL ENGINEERING FIRM. THIS DOCUMENT IS THE PROPERTY OF MERRICK & COMPANY, P.C. AND IS NOT TO BE REPRODUCED OR TRANSMITTED IN ANY FORM OR BY ANY MEANS, ELECTRONIC OR MECHANICAL, INCLUDING PHOTOCOPYING, RECORDING, OR BY ANY INFORMATION STORAGE AND RETRIEVAL SYSTEM, WITHOUT THE WRITTEN CONSENT OF MERRICK & COMPANY. ANY REUSE OR MODIFICATION OF ANY INFORMATION NOT A PART OF THIS INSTRUMENT WITHOUT THE WRITTEN CONSENT OF MERRICK & COMPANY SHALL BE AT THE USER'S SOLE RISK AND WITHOUT LIABILITY TO MERRICK & COMPANY.

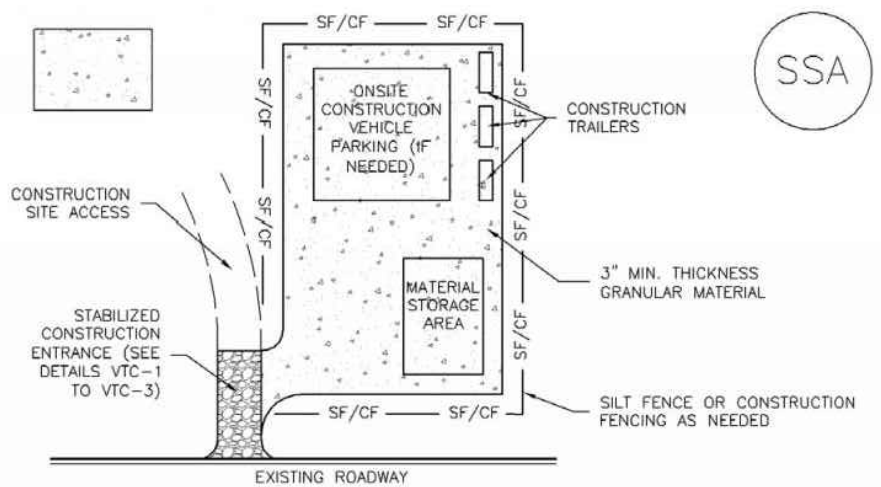
Stabilized Staging Area (SSA) SM-6



SSA-1. STABILIZED STAGING AREA

STABILIZED STAGING AREA INSTALLATION NOTES

- SEE PLAN VIEW FOR:
 - LOCATION OF STAGING AREA(S).
 - CONTRACTOR MAY ADJUST LOCATION AND SIZE OF STAGING AREA WITH APPROVAL FROM THE LOCAL JURISDICTION.
- STABILIZED STAGING AREA SHOULD BE APPROPRIATE FOR THE NEEDS OF THE SITE. OVERSIZING RESULTS IN A LARGER AREA TO STABILIZE FOLLOWING CONSTRUCTION.
- STAGING AREA SHALL BE STABILIZED PRIOR TO OTHER OPERATIONS ON THE SITE.
- THE STABILIZED STAGING AREA SHALL CONSIST OF A MINIMUM 3" THICK GRANULAR MATERIAL.
- UNLESS OTHERWISE SPECIFIED BY LOCAL JURISDICTION, ROCK SHALL CONSIST OF DOT SECT. #703, AASHTO #3 COARSE AGGREGATE OR 6" (MINUS) ROCK.
- ADDITIONAL PERIMETER BMPs MAY BE REQUIRED INCLUDING BUT NOT LIMITED TO SILT FENCE AND CONSTRUCTION FENCING AS NEEDED.

STABILIZED STAGING AREA MAINTENANCE NOTES

- INSPECT BMPs EACH WORKDAY, AND MAINTAIN THEM IN EFFECTIVE OPERATING CONDITION. MAINTENANCE OF BMPs SHOULD BE PROACTIVE, NOT REACTIVE. INSPECT BMPs AS SOON AS POSSIBLE (AND ALWAYS WITHIN 24 HOURS) FOLLOWING A STORM THAT CAUSES SURFACE EROSION, AND PERFORM NECESSARY MAINTENANCE.
- FREQUENT OBSERVATIONS AND MAINTENANCE ARE NECESSARY TO MAINTAIN BMPs IN EFFECTIVE OPERATING CONDITION. INSPECTIONS AND CORRECTIVE MEASURES SHOULD BE DOCUMENTED THOROUGHLY.
- WHERE BMPs HAVE FAILED, REPAIR OR REPLACEMENT SHOULD BE INITIATED UPON DISCOVERY OF THE FAILURE.
- ROCK SHALL BE REAPPLIED OR REGRADED AS NECESSARY IF RUTTING OCCURS OR UNDERLYING SUBGRADE BECOMES EXPOSED.

SM-6 Stabilized Staging Area (SSA)

STABILIZED STAGING AREA MAINTENANCE NOTES

- STABILIZED STAGING AREA SHALL BE ENLARGED IF NECESSARY TO CONTAIN PARKING, STORAGE, AND UNLOADING/LOADING OPERATIONS.
 - THE STABILIZED STAGING AREA SHALL BE REMOVED AT THE END OF CONSTRUCTION. THE GRANULAR MATERIAL SHALL BE REMOVED OR, IF APPROVED BY THE LOCAL JURISDICTION, USED ON SITE, AND THE AREA COVERED WITH TOPSOIL, SEED, AND MULCH, OR OTHERWISE STABILIZED IN A MANNER APPROVED BY LOCAL JURISDICTION.
- NOTE: MANY MUNICIPALITIES PROHIBIT THE USE OF RECYCLED CONCRETE AS GRANULAR MATERIAL FOR STABILIZED STAGING AREAS DUE TO DIFFICULTIES WITH RE-ESTABLISHMENT OF VEGETATION IN AREAS WHERE RECYCLED CONCRETE WAS PLACED.
- NOTE: MANY JURISDICTIONS HAVE BMP DETAILS THAT VARY FROM UDFCD STANDARD DETAILS. CONSULT WITH LOCAL JURISDICTIONS AS TO WHICH DETAIL SHOULD BE USED WHEN DIFFERENCES ARE NOTED.
- (DETAILS ADAPTED FROM DOUGLAS COUNTY, COLORADO, NOT AVAILABLE IN AUTOCAD)

AGGREGATE VEHICLE TRACKING CONTROL

INSTALLATION NOTES

- A STABILIZED CONSTRUCTION ENTRANCE/EXIT SHOULD BE LOCATED AT ALL POINTS WHERE VEHICLES EXIT THE CONSTRUCTION SITE TO ADJACENT ROADWAY.
- STABILIZED CONSTRUCTION ENTRANCE/EXITS SHALL BE INSTALLED PRIOR TO ANY LAND DISTURBING ACTIVITIES.
- RADIUS MUST BE ADEQUATE FOR INTENDED CONSTRUCTION VEHICLE TURNING.
- ROCK SHOULD CONSIST OF 6" MINUS ROCK.
- INSTALL CONSTRUCTION FENCE ON BOTH SIDES OF VEHICLE TRACKING CONTROL PAD WHEN NEEDED OR REQUIRED BY INSPECTOR.

MAINTENANCE NOTES

- FREQUENT OBSERVATIONS AND MAINTENANCE ARE NECESSARY TO MAINTAIN CONTROL MEASURES IN EFFECTIVE OPERATING CONDITION. INSPECTIONS AND CORRECTIVE MEASURES SHOULD BE DOCUMENTED THOROUGHLY.
- SEDIMENT TRACKED ONTO THE ADJACENT ROAD SHALL BE REMOVED DAILY, BY SWEEPING OR SHOVELING, AND NEVER DISTURBING ACTIVITIES.
- ROUGHEN, REPLACE AND/OR ADD ROCK AS NEEDED TO MAINTAIN CONSISTENT DEPTH AND TO PREVENT SEDIMENT TRACKING ONTO ADJACENT STREET.
- PERMANENTLY STABILIZE AREA AFTER VEHICLE TRACKING CONTROL IS REMOVED.

VEHICLE TRACKING CONTROL

ISSUED: 10/7/19 REVISION: 8/19/2020 DRAWING NO: 900-VTC

CHECK DAM ELEVATION VIEW

SECTION A-A'

SECTION B-B'

PROFILE

INSTALLATION NOTES

- CHECK DAMS SHOULD BE INSTALLED BEFORE UPSTREAM LAND DISTURBING ACTIVITIES.
- RIPRAP PAD SHOULD BE TRENCHED INTO GROUND BY A MINIMUM OF 6".

MAINTENANCE NOTES

- FREQUENT OBSERVATIONS AND MAINTENANCE ARE NECESSARY TO MAINTAIN CONTROL MEASURES IN EFFECTIVE OPERATING CONDITION. INSPECTIONS AND CORRECTIVE MEASURES SHOULD BE DOCUMENTED THOROUGHLY.
- ACCUMULATED SEDIMENT MUST BE REMOVED WHEN THE HEIGHT REACHES 1/2 THE HEIGHT OF THE CHECK DAM CREST.
- CHECK DAMS MUST REMAIN UNTIL THE UPSTREAM DISTURBANCE AREA IS STABILIZED.
- PERMANENTLY STABILIZE AREA AFTER CHECK DAMS ARE REMOVED IF REMOVAL IS REQUIRED.

CHECK DAM

ISSUED: 10/7/19 REVISION: 8/19/2020 DRAWING NO: 900-CD

CONCRETE WASHOUT AREA PLAN

SECTION A-A'

CONCRETE WASHOUT AREA

ISSUED: 10/7/19 REVISION: 8/19/2020 DRAWING NO: 900-CWA-1

INSTALLATION NOTES

- SEE PLAN VIEW FOR:
 - LOCATION OF CONCRETE WASHOUT AREA
 - LOCATE AT LEAST 50' AWAY FROM STATE WATERS MEASURED HORIZONTALLY.
 - AN IMPERMEABLE LINER (16 MIL. MINIMUM THICKNESS) IS REQUIRED IF CONCRETE WASH AREA IS LOCATED WITHIN 400' OF STATE WATERS OR 1000' OF WELLS OR DRINKING WATER SOURCES.
 - DO NOT LOCATE IN AREAS WHERE SHALLOW GROUNDWATER MAY BE PRESENT.
 - THE CONCRETE WASH AREA SHALL BE INSTALLED PRIOR TO CONCRETE PLACEMENT ON SITE.
 - CONCRETE WASH AREA SHALL INCLUDE A FLAT SUBSURFACE PIT THAT IS AT LEAST 8' BY 6'.
 - BERM SURROUNDING SIDES AND BACK OF CONCRETE WASH AREA SHALL HAVE A MINIMUM HEIGHT OF 2 FEET.
 - CONCRETE WASH AREA ENTRANCE SHALL BE SLOPED 2% TOWARDS THE CONCRETE WASH AREA.
 - SIGNS SHALL BE PLACED AT THE CONCRETE WASH AREA.
 - USE EXCAVATED MATERIAL FOR PERIMETER BERM CONSTRUCTION.

MAINTENANCE NOTES

- FREQUENT OBSERVATIONS AND MAINTENANCE ARE NECESSARY TO MAINTAIN CONTROL MEASURES IN EFFECTIVE OPERATING CONDITION. INSPECTIONS AND CORRECTIVE MEASURES SHOULD BE DOCUMENTED THOROUGHLY.
- THE CONCRETE WASH AREA SHALL BE REPAIRED, CLEANED, OR ENLARGED AS NECESSARY TO MAINTAIN CAPACITY FOR CONCRETE WASTE. CONCRETE MATERIALS ACCUMULATED IN THE PIT SHALL BE REMOVED ONCE THE MATERIALS HAVE REACHED A DEPTH OF 1/2 THE HEIGHT OF THE CONCRETE WASH AREA.
- CONCRETE WASHOUT WATER, WASTED PIECES OF CONCRETE, AND ALL OTHER DEBRIS IN THE SUBSURFACE PIT SHALL BE TRANSPORTED FROM THE JOB SITE IN A WATER-TIGHT CONTAINER AND DISPOSED OF PROPERLY. THE CONCRETE WASH AREA SHALL REMAIN IN PLACE UNTIL ALL CONCRETE FOR THE PROJECT IS PLACED.
- PERMANENTLY STABILIZE AREA AFTER CONCRETE WASH AREA IS REMOVED.

CONCRETE WASHOUT AREA

ISSUED: 10/7/19 REVISION: 8/19/2020 DRAWING NO: 900-CWA-3

SM-3 Construction Fence (CF)

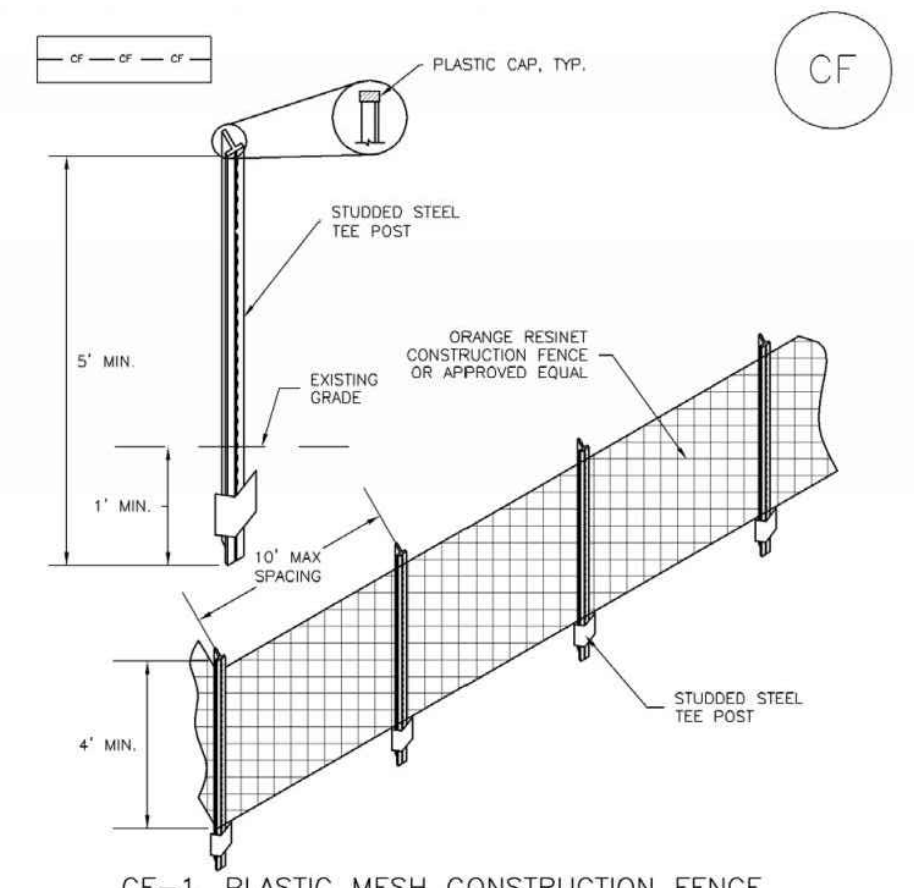

CONSTRUCTION FENCE INSTALLATION NOTES

- SEE PLAN VIEW FOR:
 - LOCATION OF CONSTRUCTION FENCE.
- CONSTRUCTION FENCE SHOWN SHALL BE INSTALLED PRIOR TO ANY LAND DISTURBING ACTIVITIES.
- CONSTRUCTION FENCE SHALL BE COMPOSED OF ORANGE, CONTRACTOR-GRADE MATERIAL THAT IS AT LEAST 4' HIGH. METAL POSTS SHOULD HAVE A PLASTIC CAP FOR SAFETY.
- STUDDED STEEL TEE POSTS SHALL BE UTILIZED TO SUPPORT THE CONSTRUCTION FENCE. MAXIMUM SPACING FOR STEEL TEE POSTS SHALL BE 10'.
- CONSTRUCTION FENCE SHALL BE SECURELY FASTENED TO THE TOP, MIDDLE, AND BOTTOM OF EACH POST.

Construction Fence (CF) SM-3

CONSTRUCTION FENCE MAINTENANCE NOTES

- INSPECT BMPs EACH WORKDAY, AND MAINTAIN THEM IN EFFECTIVE OPERATING CONDITION. MAINTENANCE OF BMPs SHOULD BE PROACTIVE, NOT REACTIVE. INSPECT BMPs AS SOON AS POSSIBLE (AND ALWAYS WITHIN 24 HOURS) FOLLOWING A STORM THAT CAUSES SURFACE EROSION, AND PERFORM NECESSARY MAINTENANCE.
 - FREQUENT OBSERVATIONS AND MAINTENANCE ARE NECESSARY TO MAINTAIN BMPs IN EFFECTIVE OPERATING CONDITION. INSPECTIONS AND CORRECTIVE MEASURES SHOULD BE DOCUMENTED THOROUGHLY.
 - WHERE BMPs HAVE FAILED, REPAIR OR REPLACEMENT SHOULD BE INITIATED UPON DISCOVERY OF THE FAILURE.
 - CONSTRUCTION FENCE SHALL BE REPAIRED OR REPLACED WHEN THERE ARE SIGNS OF DAMAGE SUCH AS RIPS OR SAGS. CONSTRUCTION FENCE IS TO REMAIN IN PLACE UNTIL THE UPSTREAM DISTURBED AREA IS STABILIZED AND APPROVED BY THE LOCAL JURISDICTION.
 - WHEN CONSTRUCTION FENCES ARE REMOVED, ALL DISTURBED AREAS ASSOCIATED WITH THE INSTALLATION, MAINTENANCE, AND/OR REMOVAL OF THE FENCE SHALL BE COVERED WITH TOPSOIL, SEED, AND MULCH, OR OTHERWISE STABILIZED AS APPROVED BY LOCAL JURISDICTION.
- NOTE: MANY JURISDICTIONS HAVE BMP DETAILS THAT VARY FROM UDFCD STANDARD DETAILS. CONSULT WITH LOCAL JURISDICTIONS AS TO WHICH DETAIL SHOULD BE USED WHEN DIFFERENCES ARE NOTED.
- (DETAIL ADAPTED FROM TOWN OF PARKER, COLORADO, NOT AVAILABLE IN AUTOCAD)

File Location: D:\Denver_North\Projects\City of Colorado Springs\Sand Creek Pond No. 2\CAD\CD\9075-GESC details.dwg Plot Date: 8/27/2024 11:23 AM Last Saved By: TIM.MCMULLEN

REV	REVISION DESCRIPTION	DATE	CHND	CHKD	APPR

CALL BEFORE YOU DIG

CITY OF COLORADO SPRINGS
30 S. NEVADA AVE., SUITE 401
COLORADO SPRINGS, CO 80903
(719) 385-5980

MERRICK

Engineering | Architecture | Design-Build | Surveying | Planning | Geospatial Solutions

2480 W. 26TH AVE., UNIT B225 - DENVER COLORADO 80211
TEL. 303-751-0741, FAX 303-751-2581
www.merrick.com

PE STAMP

FOR AND ON BEHALF OF MERRICK & COMPANY

TITLE

SAND CREEK DETENTION POND NO. 2

GRADING AND EROSION CONTROL (GEC) DETAILS (1 OF 3)

JOB NUMBER: 65420975

DATE: AUGUST 2024

SHEET: **EC-401**

7 of 9

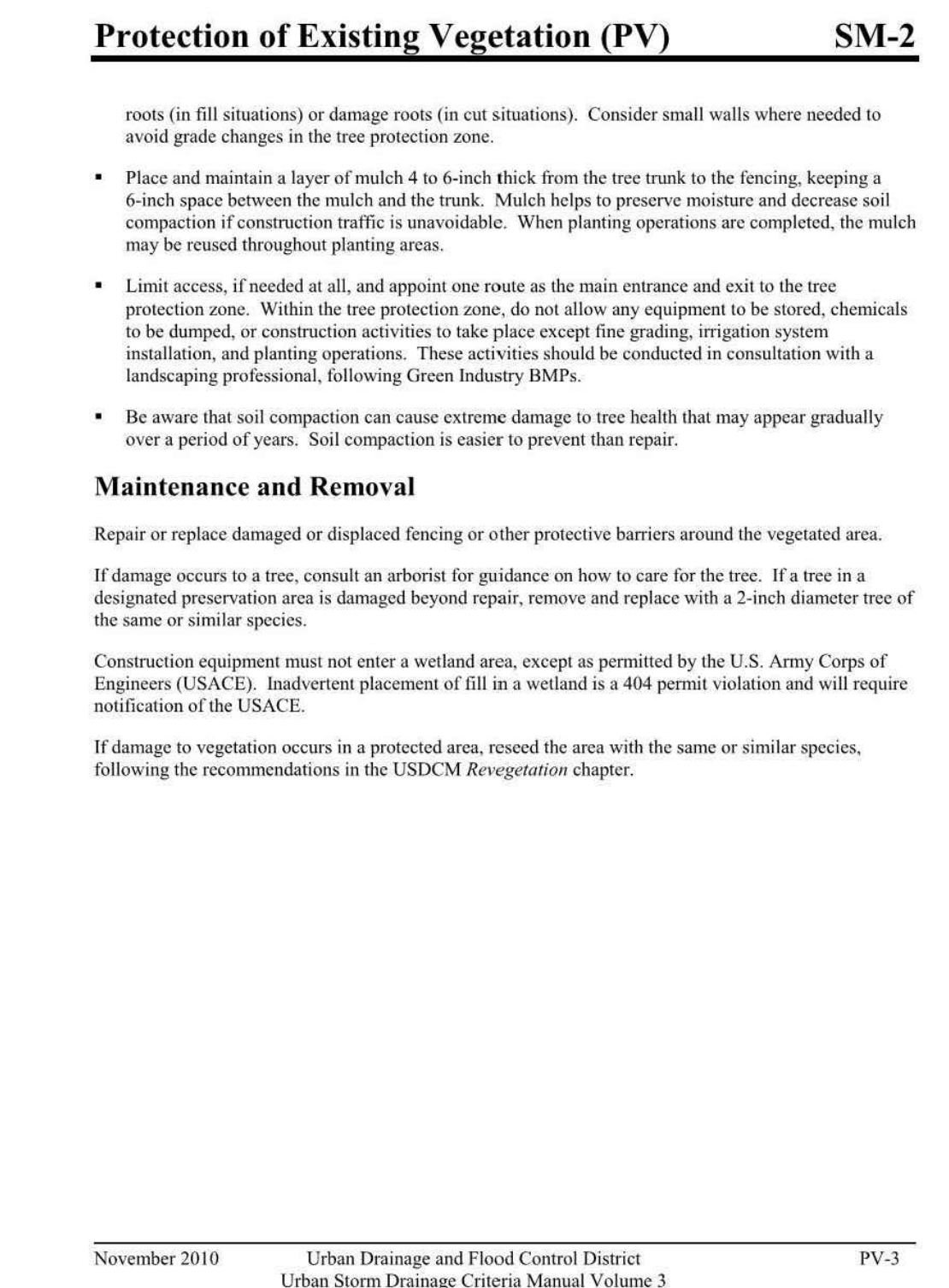
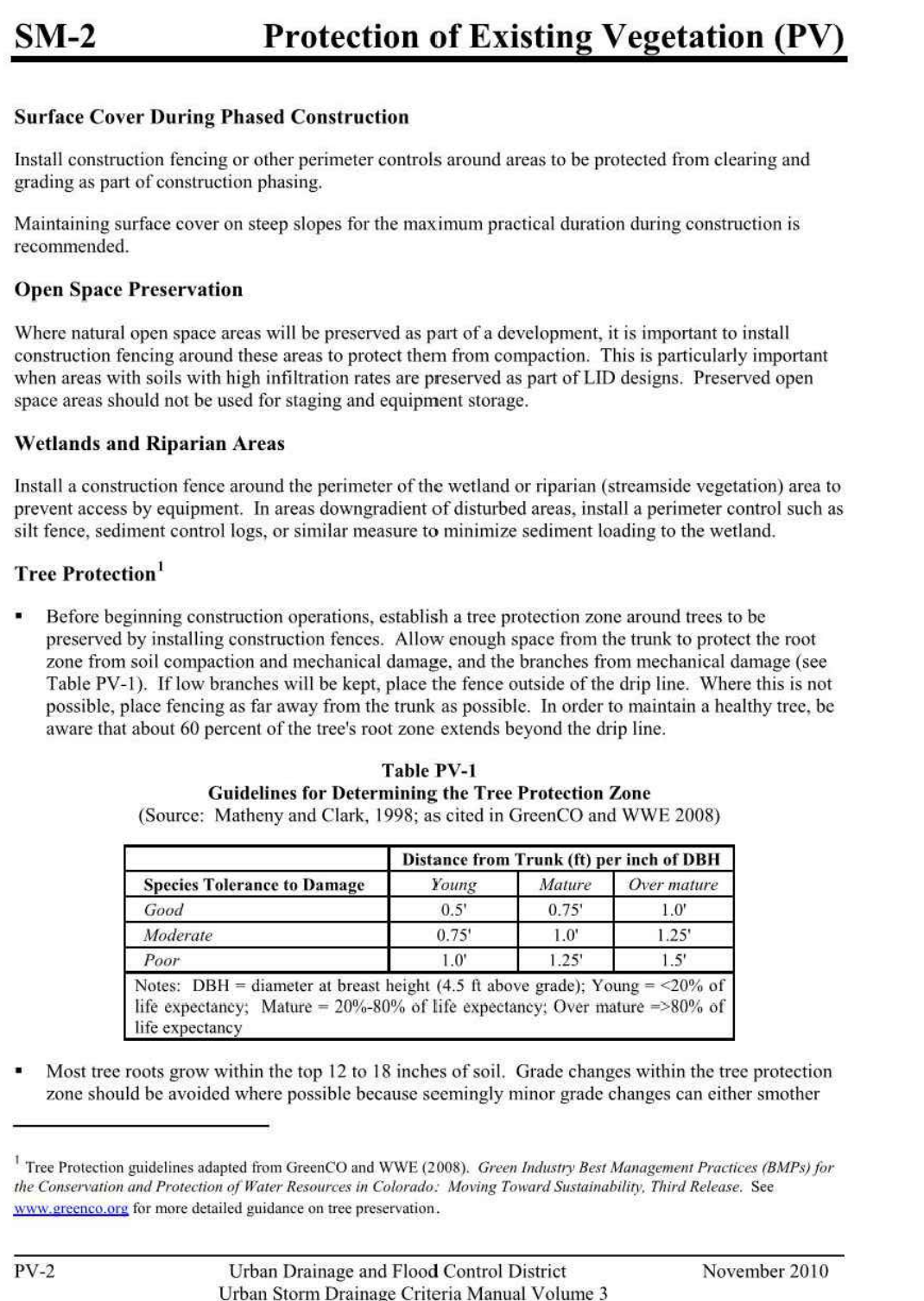
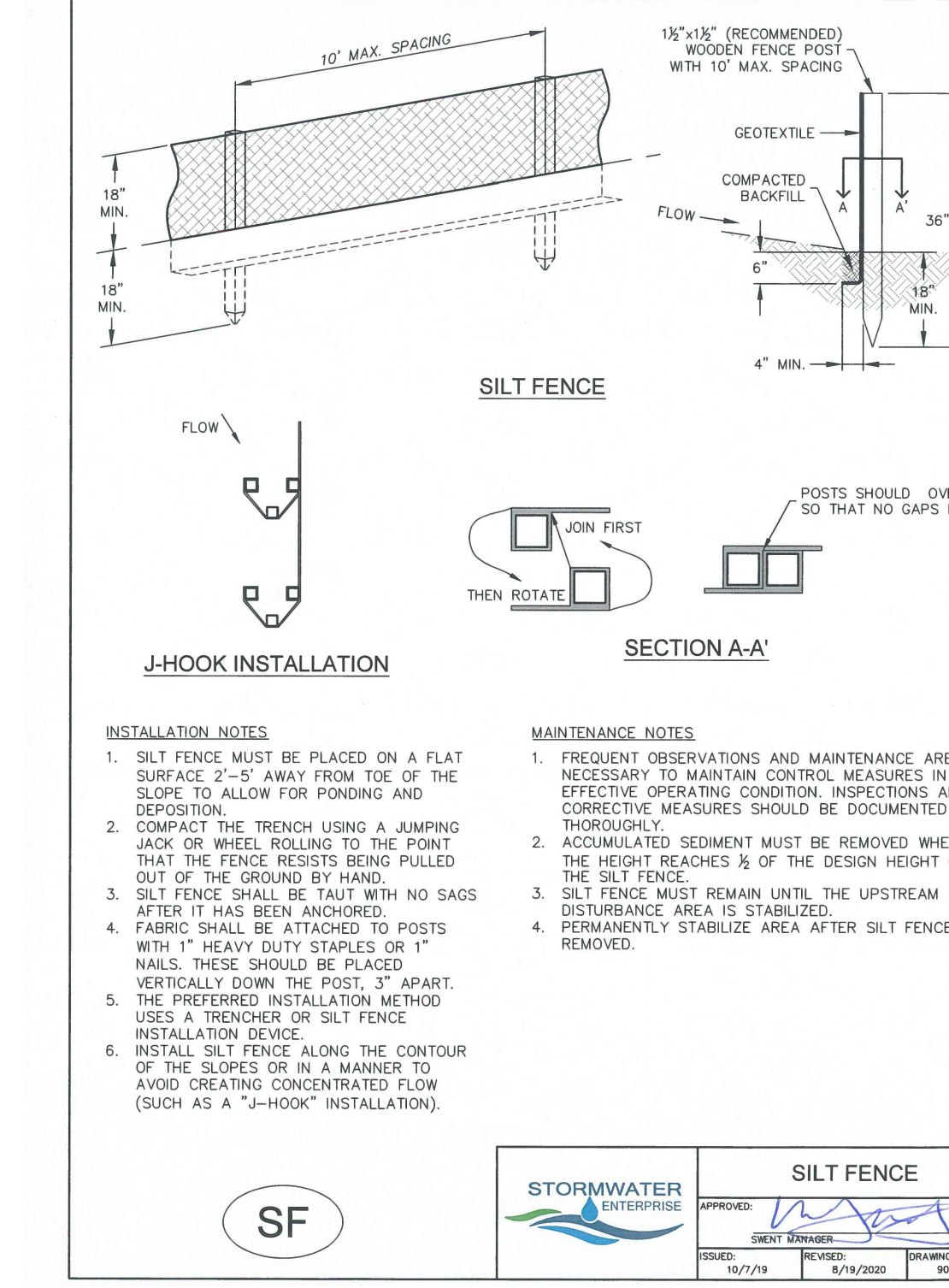
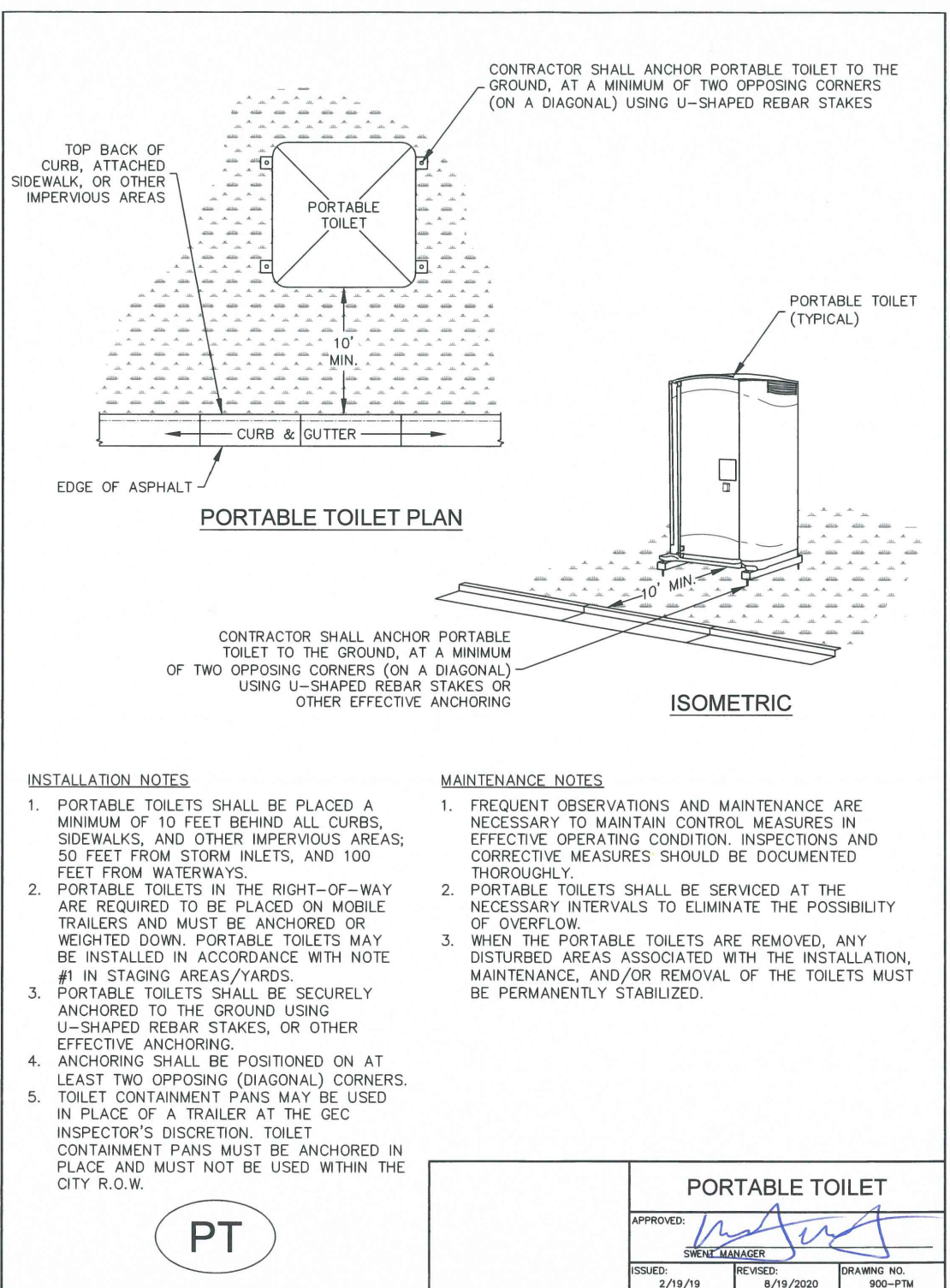
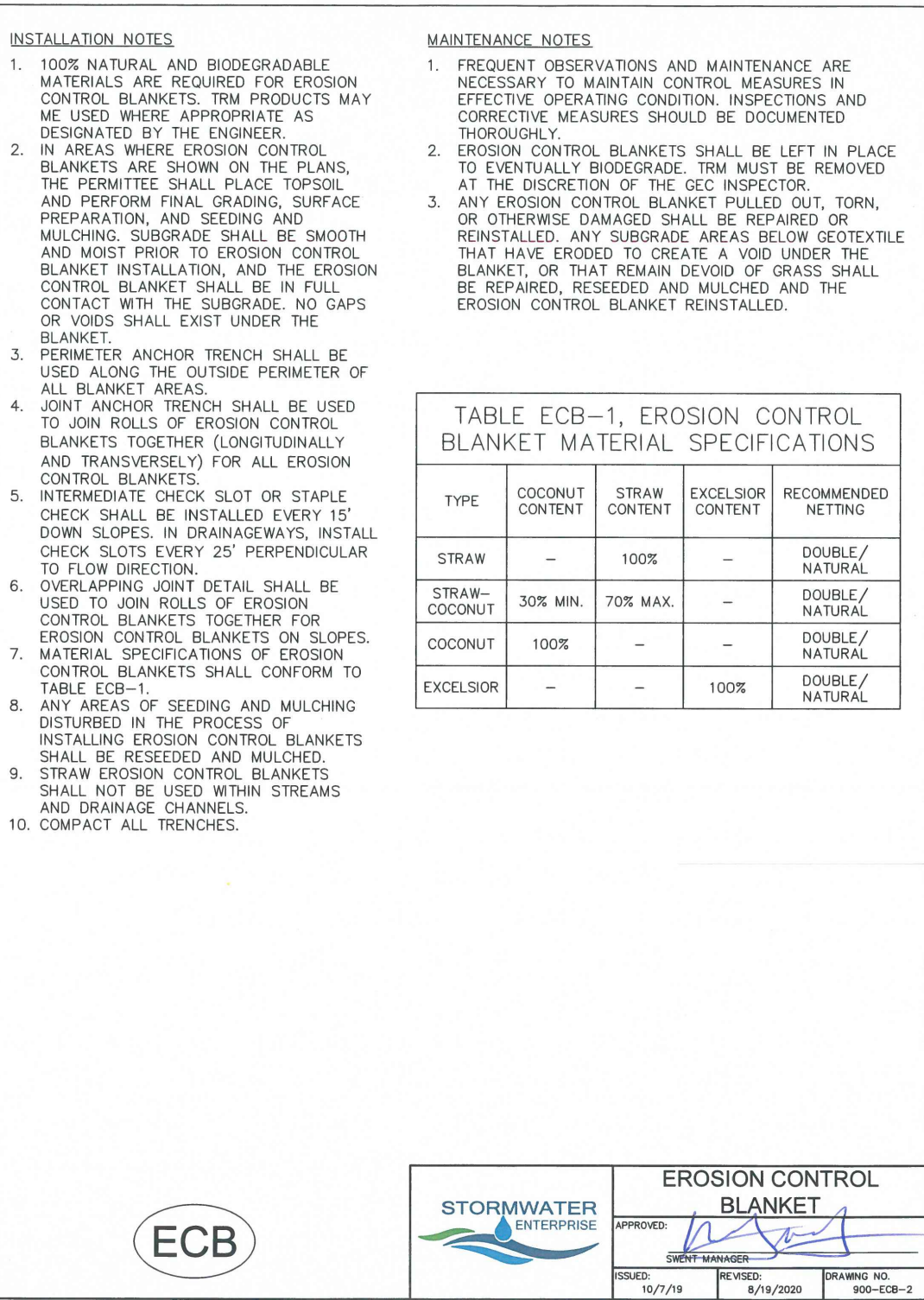
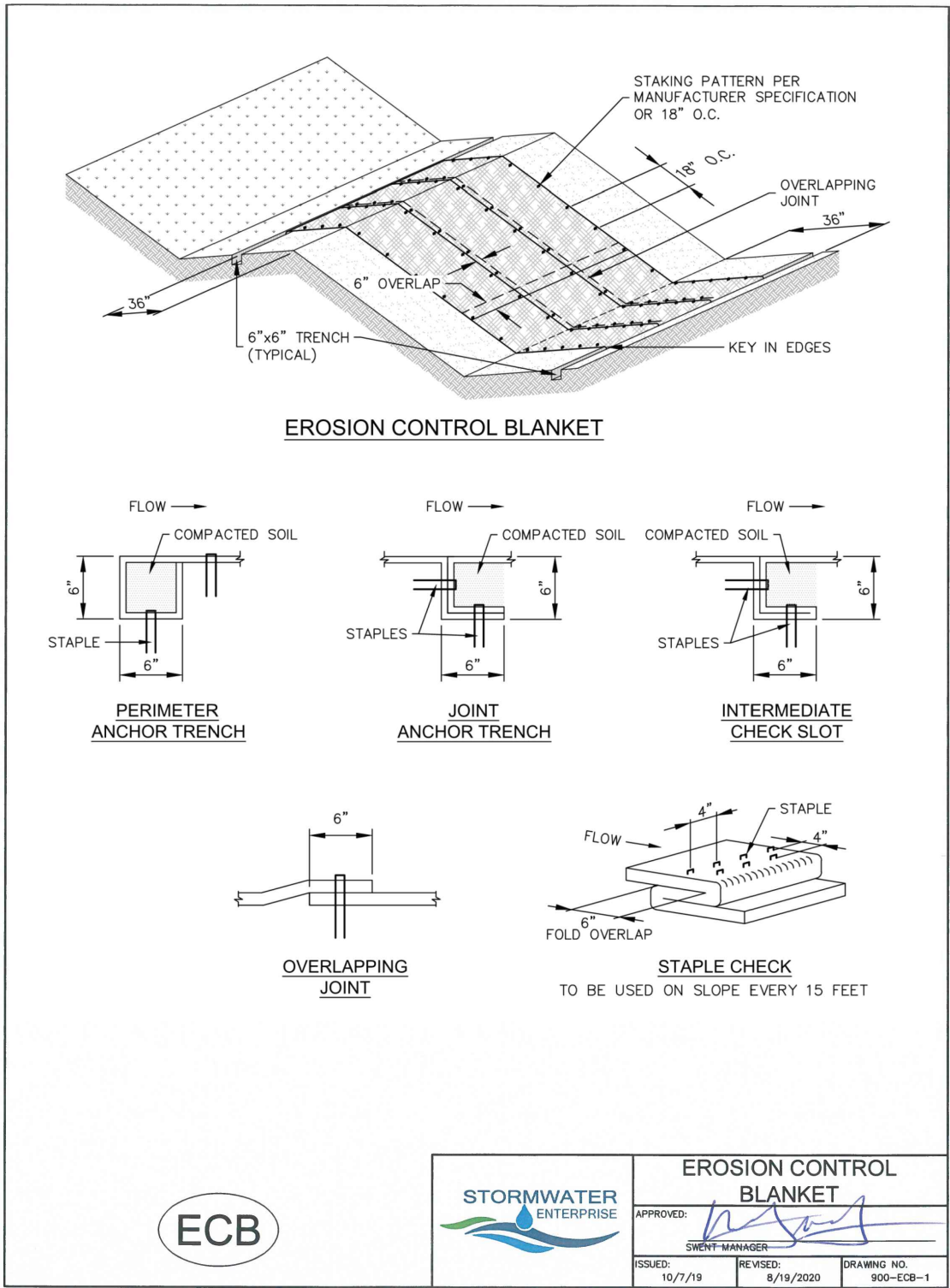

CALL BEFORE YOU DIG

Know what's below. Call before you dig.

REV	REVISION DESCRIPTION	DATE	CHND	CHKD	APPR

811 logo

Know what's below. Call before you dig.

CITY OF COLORADO SPRINGS
30 S. NEVADA AVE., SUITE 401
COLORADO SPRINGS, CO 80903
(719) 385-5980

MERRICK
Engineering | Architecture | Design-Build | Surveying | Planning | Geospatial Solutions
2480 W. 26TH AVE., UNIT B225 - DENVER COLORADO 80211
TEL. 303-751-0741, FAX 303-751-2581
www.merrick.com

PE STAMP

FOR AND ON BEHALF OF MERRICK & COMPANY

TITLE

SAND CREEK DETENTION POND NO. 2

GRADING AND EROSION CONTROL (GEC) DETAILS (2 OF 3)

JOB NUMBER: 65420975
DATE: AUGUST 2024
SHEET: EC-402
8 of 9

8 of 9

506 of 507

THE CITY OF COLORADO SPRINGS, COLORADO, IS AN INSTRUMENT OF SERVICE PROVIDED BY MERRICK AND COMPANY FOR A SERVICE PROJECT. REUSE OR MODIFICATION OF ANY UTILITY OR INFRASTRUCTURE TO BE SUITABLE FOR REUSE OR PART OR EXTENSION OF THE PROJECT OR ON ANY OTHER PROJECT SHALL BE AT THE USER'S RISK AND WITHOUT LIABILITY TO MERRICK AND COMPANY.

File Location: D:\Denver_North\Projects\City of Colorado Springs\Sand Creek Pond No 2\CAD\03\03\0975-GESC details.dwg Plot Date: 8/27/2024 11:23 AM Last Saved By: TIM.MCMULLEN

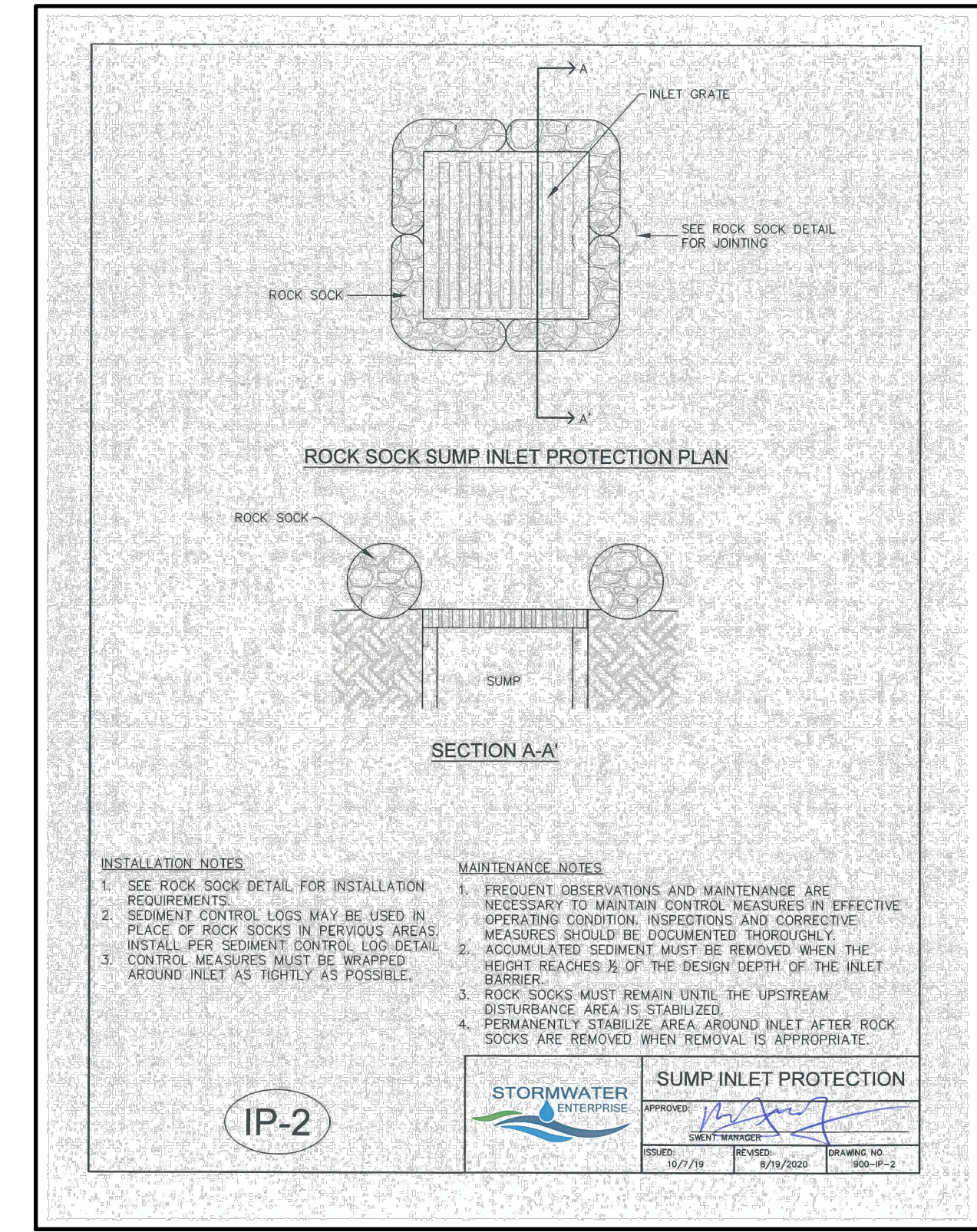
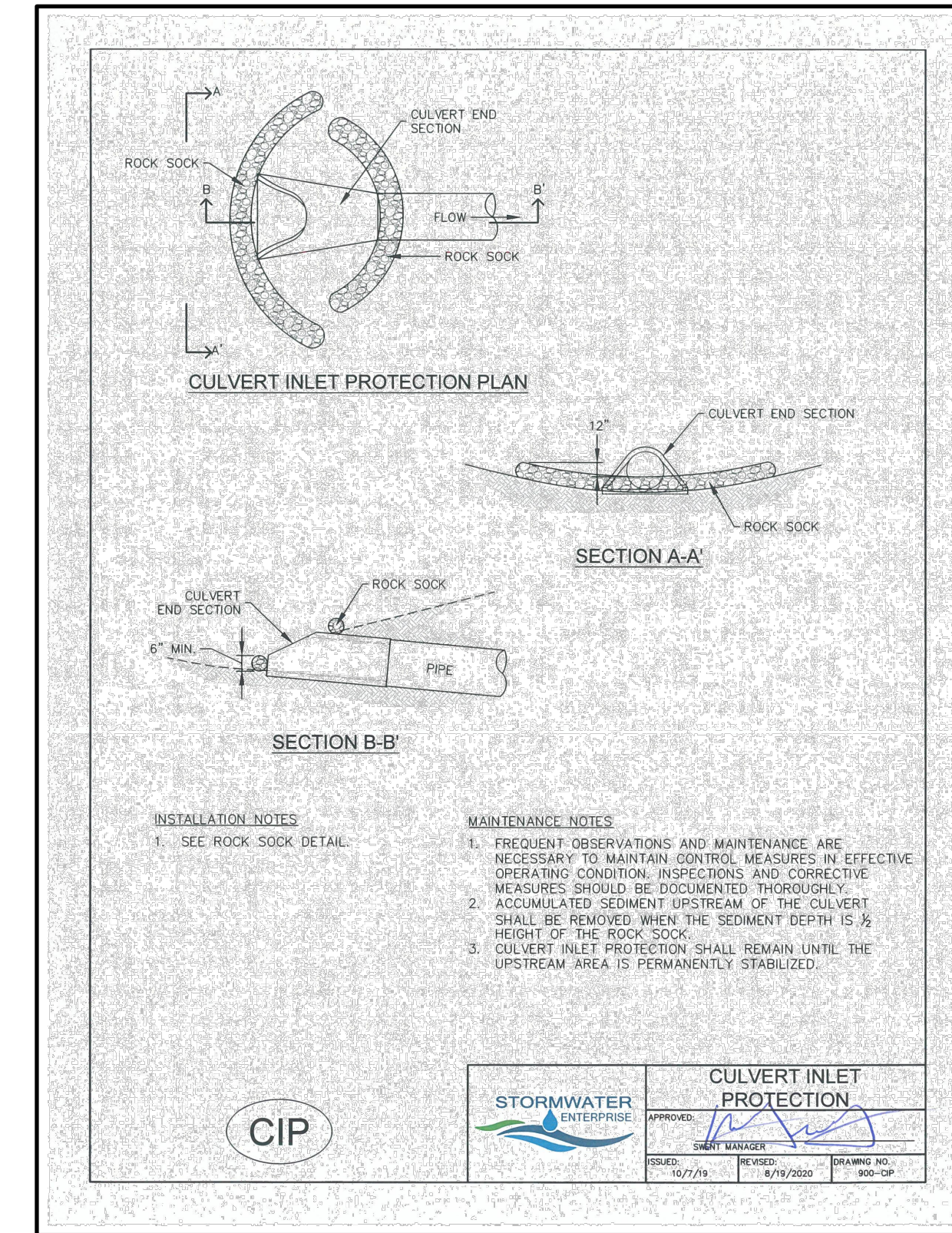

REV	REVISION DESCRIPTION	DATE	CHND	CHKD	APPR

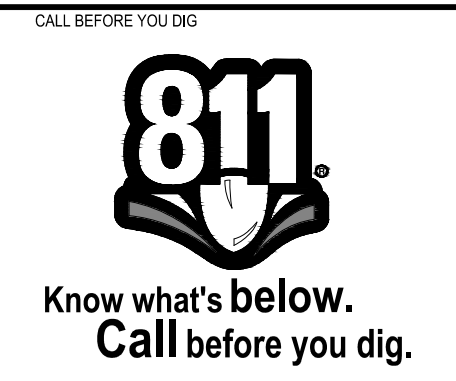

CITY OF COLORADO SPRINGS
 30 S. NEVADA AVE., SUITE 401
 COLORADO SPRINGS, CO 80903
 (719) 385-5980

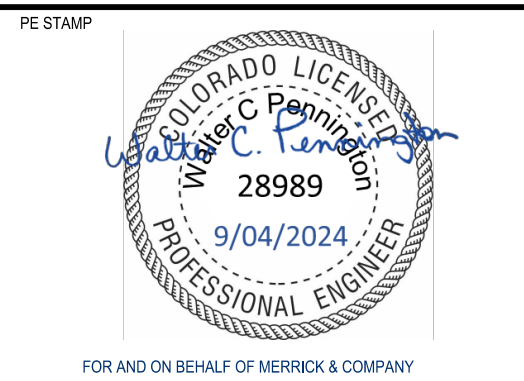

SAND CREEK DETENTION POND NO. 2
 GRADING AND EROSION CONTROL (GEC) DETAILS (3 OF 3)

JOB NUMBER: 65420975
 DATE: AUGUST 2024
 SHEET: EC-403
 9 of 9